



ARM Cortex™ -M0
32-BIT MICROCONTROLLER

NuMicro™ Family
M052/M054BN Data Sheet



TABLE OF CONTENTS

1 GENERAL DESCRIPTION 6

2 FEATURES 7

3 BLOCK DIAGRAM 11

4 SELECTION TABLE 12

5 PIN CONFIGURATION 13

 5.1 QFN 33 pin13

 5.2 LQFP 48 pin14

 5.3 Pin Description.....15

6 FUNCTIONAL DESCRIPTION 19

 6.1 ARM® Cortex™-M0 Core19

 6.2 System Manager21

 6.2.1 Overview.....21

 6.2.2 System Reset21

 6.2.3 System Power Architecture22

 6.2.4 Whole System Memory Map23

 6.2.5 Whole System Memory Mapping Table.....25

 6.2.6 System Timer (SysTick).....25

 6.2.7 Nested Vectored Interrupt Controller (NVIC)27

 6.3 Clock Controller28

 6.3.1 Overview.....28

 6.3.2 Clock Generator Block Diagram28

 6.3.3 System Clock & SysTick Clock.....30

 6.3.4 AHB Clock Source Select31

 6.3.5 Peripherals Clock Source Select32

 6.3.6 Power Down Mode (Deep Sleep Mode) Clock.....33

 6.3.7 Frequency Divider Output33

 6.4 General Purpose I/O35

 6.4.1 Overview.....35

 6.5 I²C Serial Interface Controller (Master/Slave)37

 6.5.1 Overview.....37

 6.5.2 Features.....38

 6.6 PWM Generator and Capture Timer.....39

 6.6.1 Overview.....39

 6.6.2 Features.....40

 6.7 Serial Peripheral Interface (SPI)41

 6.7.1 Overview.....41

 6.7.2 Features.....41

 6.8 Timer Controller42

 6.8.1 Overview.....42



6.8.2	Features:	42
6.9	Watchdog Timer (WDT)	43
6.9.1	Overview	43
6.9.2	Features	44
6.10	UART Interface Controller (UART)	45
6.10.1	Overview	45
6.10.2	Features	47
6.11	Analog-to-Digital Converter (ADC)	48
6.11.1	Overview	48
6.11.2	Features	48
6.12	External Bus Interface (EBI)	49
6.12.1	Overview	49
6.12.2	Features	49
6.13	Flash Memory Controller (FMC)	50
6.13.1	Overview	50
6.13.2	Features	50
7	TYPICAL APPLICATION CIRCUIT	51
8	ELECTRICAL CHARACTERISTICS	52
8.1	Absolute Maximum Ratings	52
8.2	DC Electrical Characteristics	53
8.3	AC Electrical Characteristics	57
8.3.1	External Crystal	57
8.3.2	External Oscillator	57
8.3.3	Typical Crystal Application Circuits	58
8.3.4	Internal 22.1184 MHz RC Oscillator	59
8.3.5	Internal 10kHz RC Oscillator	59
8.4	Analog Characteristics	60
8.4.1	Specification of 12-bit SARADC	60
8.4.2	Specification of LDO & Power management	61
8.4.3	Specification of Low Voltage Reset	62
8.4.4	Specification of Brown-Out Detector	62
8.4.5	Specification of Power-On Reset (5V)	62
8.4.6	Specification of Temperature Sensor	63
8.4.7	Specification of Comparator	63
8.5	Flash DC Electrical Characteristics	64
9	PACKAGE DIMENSIONS	65
9.1	LQFP-48 (7x7x1.4mm ² Footprint 2.0mm)	65
9.2	QFN-33 (5X5 mm ² , Thickness 0.8mm, Pitch 0.5 mm)	66
10	REVISION HISTORY	67

LIST OF FIGURES

Figure 3-1 NuMicro™ M051 Series Block Diagram.....	11
Figure 4-1 NuMicro™ Naming Rule.....	12
Figure 5-1 NuMicro™ M051 Series QFN33 Pin Diagram.....	13
Figure 5-2 NuMicro™ M051 Series LQFP-48 Pin Diagram.....	14
Figure 6-1 Functional Block Diagram.....	19
Figure 6-2 NuMicro M051™ Series Power Architecture Diagram	22
Figure 6-3 Clock generator block diagram	29
Figure 6-4 System Clock Block Diagram	30
Figure 6-5 SysTick clock Control Block Diagram.....	30
Figure 6-6 AHB Clock Source for HCLK.....	31
Figure 6-7 Peripherals Clock Source Select for PCLK	32
Figure 6-8 Clock Source of Frequency Divider	33
Figure 6-9 Block Diagram of Frequency Divider	34
Figure 6-10 Push-Pull Output.....	35
Figure 6-11 Open-Drain Output	36
Figure 6-12 Quasi-bidirectional I/O Mode	36
Figure 6-13 I ² C Bus Timing.....	37
Figure 6-14 Timing of Interrupt and Reset Signal.....	44
Figure 8-1 Typical Crystal Application Circuit	58



LIST OF TABLES

Table 4-1 NuMicro™ M051 Series Product Selection Guide	12
Table 5-1 NuMicro™ M051 Series Pin Description	17
Table 6-1 Address Space Assignments for On-Chip Modules	24
Table 6-2 Watchdog Timeout Interval Selection	43
Table 6-3 UART Baud Rate Equation	45
Table 6-4 UART Baud Rate Setting Table	46



1 GENERAL DESCRIPTION

The NuMicro M051™ series is a 32-bit microcontroller with embedded ARM® Cortex™-M0 core for industrial control and applications which need rich communication interfaces. The Cortex™-M0 is the newest ARM embedded processor with 32-bit performance and at a cost equivalent to traditional 8-bit microcontroller. The NuMicro M051™ series includes M052, M054, M058 and M0516 families.

The M052/M054 can run up to 50 MHz. Thus it can afford to support a variety of industrial control and applications which need high CPU performance. The M052/M054 has 8K/16K-byte embedded flash, 4K-byte data flash, 4K-byte flash for the ISP, and 4K-byte embedded SRAM.

Many system level peripheral functions, such as I/O Port, EBI (External Bus Interface), Timer, UART, SPI, I2C, PWM, ADC, Watchdog Timer and Brownout Detector, have been incorporated into the M052/M054 in order to reduce component count, board space and system cost. These useful functions make the M052/M054 powerful for a wide range of applications.

Additionally, the M052/M054 is equipped with ISP (In-System Programming) and ICP (In-Circuit Programming) functions, which allow the user to update the program memory without removing the chip from the actual end product.



2 FEATURES

- Core
 - ARM® Cortex™ -M0 core runs up to 50 MHz.
 - One 24-bit system timer.
 - Supports low power sleep-mode.
 - A single-cycle 32-bit hardware multiplier.
 - NVIC for the 32 interrupt inputs, each with 4-levels of priority.
 - Supports Serial Wire Debug (SWD) interface and 2 watchpoints/4 breakpoints.
- Built-in LDO for Wide Operating Voltage Range: 2.5V to 5.5V
- Memory
 - 8KB/16KB Flash memory for program memory (APROM)
 - 4KB Flash memory for data memory (DataFlash)
 - 4KB Flash memory for loader (LDRAM)
 - 4KB SRAM for internal scratch-pad RAM (SRAM)
- Clock Control
 - Programmable system clock source
 - 4~24 MHz external crystal input
 - 22.1184 MHz internal oscillator (trimmed to 3% accuracy)
 - 10 kHz low-power oscillator for Watchdog Timer and wake-up in sleep mode
 - PLL allows CPU operation up to the maximum 50MHz
- I/O Port
 - Up to 40 general-purpose I/O (GPIO) pins for LQFP-48 package
 - Four I/O modes:
 - ◆ Quasi bi-direction
 - ◆ Push-Pull output
 - ◆ Open-Drain output



- ◆ Input only with high impedance
- TTL/Schmitt trigger input selectable
- I/O pin can be configured as interrupt source with edge/level setting
- Supports high driver and high sink IO mode
- Timer
 - Provides four channel 32-bit timers, one 8-bit pre-scale counter with 24-bit up-timer for each timer.
 - Independent clock source for each timer.
 - 24-bit timer value is readable through TDR (Timer Data Register)
 - Provides one-shot, periodic and toggle operation modes.
 - Provide event counter function.
 - Provide external capture/reset counter function equivalent to 8051 Timer2.
- Watchdog Timer
 - Multiple clock sources
 - Supports wake up from power down or sleep mode
 - Interrupt or reset selectable on watchdog time-out
- PWM
 - Built-in up to four 16-bit PWM generators; providing eight PWM outputs or four complementary paired PWM outputs
 - Individual clock source, clock divider, 8-bit pre-scalar and dead-zone generator for each PWM generator
 - PWM interrupt synchronized to PWM period
 - 16-bit digital Capture timers (shared with PWM timers) with rising/falling capture inputs
 - Supports capture interrupt
- UART
 - Up to two sets of UART device
 - Programmable baud-rate generator
 - Buffered receiver and transmitter, each with 15 bytes FIFO



- Optional flow control function (CTS and RTS)
- Supports IrDA(SIR) function
- Supports RS485 function
- Supports LIN function
- SPI
 - Up to two sets of SPI device.
 - Supports master/slave mode
 - Full duplex synchronous serial data transfer
 - Provide 3 wire function
 - Variable length of transfer data from 1 to 32 bits
 - MSB or LSB first data transfer
 - Rx latching data can be either at rising edge or at falling edge of serial clock
 - Tx sending data can be either at rising edge or at falling edge of serial clock
 - Supports Byte suspend mode in 32-bit transmission
- I²C
 - Supports master/slave mode
 - Bidirectional data transfer between masters and slaves
 - Multi-master bus (no central master).
 - Arbitration between simultaneously transmitting masters without corruption of serial data on the bus
 - Serial clock synchronization allows devices with different bit rates to communicate via one serial bus.
 - Serial clock synchronization can be used as a handshake mechanism to suspend and resume serial transfer.
 - Programmable clocks allow versatile rate control.
 - Supports multiple address recognition (four slave address with mask option)
- ADC
 - 12-bit SAR ADC with 760k SPS



- Up to 8-ch single-ended input or 4-ch differential input
- Supports single mode/burst mode/single-cycle scan mode/continuous scan mode
- Supports 2' complement/un-signed format in differential mode conversion result
- Each channel with an individual result register
- Supports conversion value monitoring (or comparison) for threshold voltage detection
- Conversion can be started either by software trigger or external pin trigger
- Analog Comparator
 - Up to 2 comparator analog modules
 - External input or internal band gap voltage selectable at negative node
 - Interrupt when compare result change
 - Power down wake up
- EBI (External Bus Interface) for external memory-mapped device access
 - Accessible space: 64KB in 8-bit mode or 128KB in 16-bit mode
 - Supports 8-bit/16-bit data width
 - Supports byte-write in 16-bit data width
- In-System Programming (ISP) and In-Circuit Programming (ICP)
- One built-in temperature sensor with 1°C resolution
- Brown-Out Detector
 - With 4 levels: 4.3V/3.7V/2.7V/2.2V
 - Supports Brown-Out interrupt and reset option
- 96-bit unique ID
- LVR (Low Voltage Reset)
 - Threshold voltage levels: 2.0V
- Operating Temperature: -40°C ~85°C
- Packages:
 - Green package (RoHS)
 - 48-pin LQFP, 33-pin QFN

3 BLOCK DIAGRAM

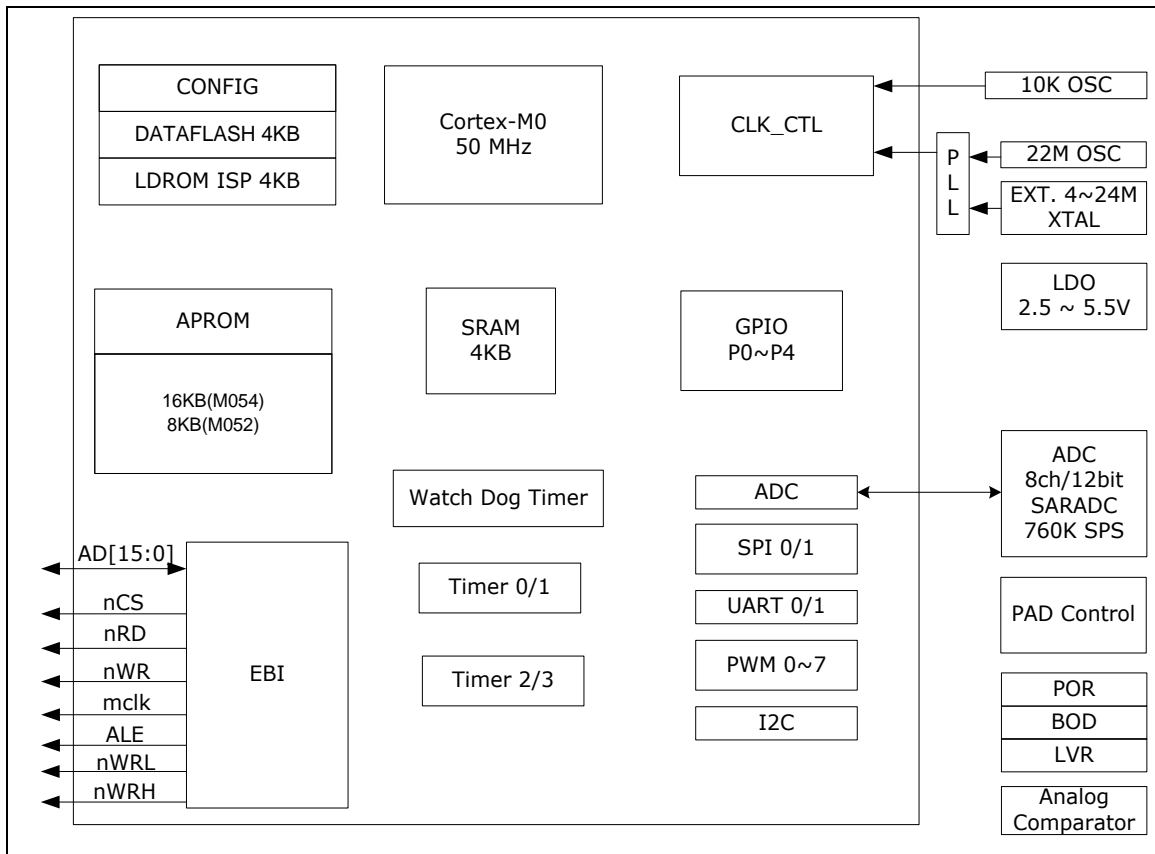

Figure 3-1 NuMicro™ M051 Series Block Diagram

4 SELECTION TABLE

NuMicro M051™ Series Selection Guide

Part number	APROM	RAM	Data Flash	LDROM	I/O	Timer	Connectivity			COMP	PWM	ADC	EBI	ISP ICP	Package
							UART	SPI	I2C						
M052LBN	8KB	4KB	4KB	4KB	40	4x32-bit	2	2	1	2	8	8X12-bit	v	v	LQFP48
M052ZBN	8KB	4KB	4KB	4KB	24	4x32-bit	2	1	1	2	5	8X12-bit		v	QFN33
M054LBN	16KB	4KB	4KB	4KB	40	4x32-bit	2	2	1	2	8	8X12-bit	v	v	LQFP48
M054ZBN	16KB	4KB	4KB	4KB	24	4x32-bit	2	1	1	2	5	8X12-bit		v	QFN33

Table 4-1 NuMicro™ M051 Series Product Selection Guide

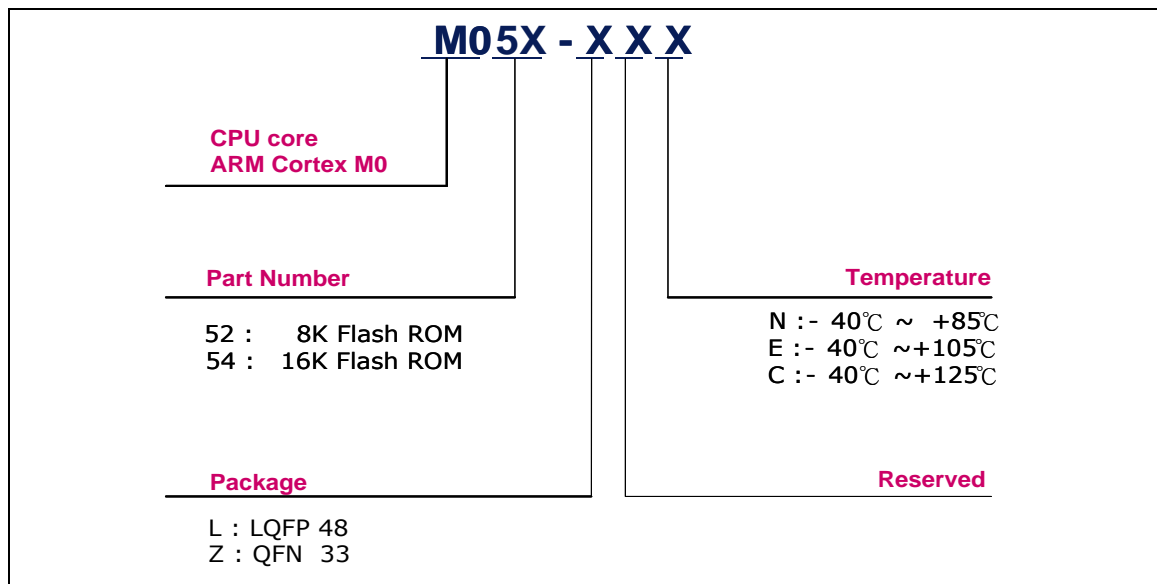

Figure 4-1 NuMicro™ Naming Rule



5 PIN CONFIGURATION

5.1 QFN 33 pin

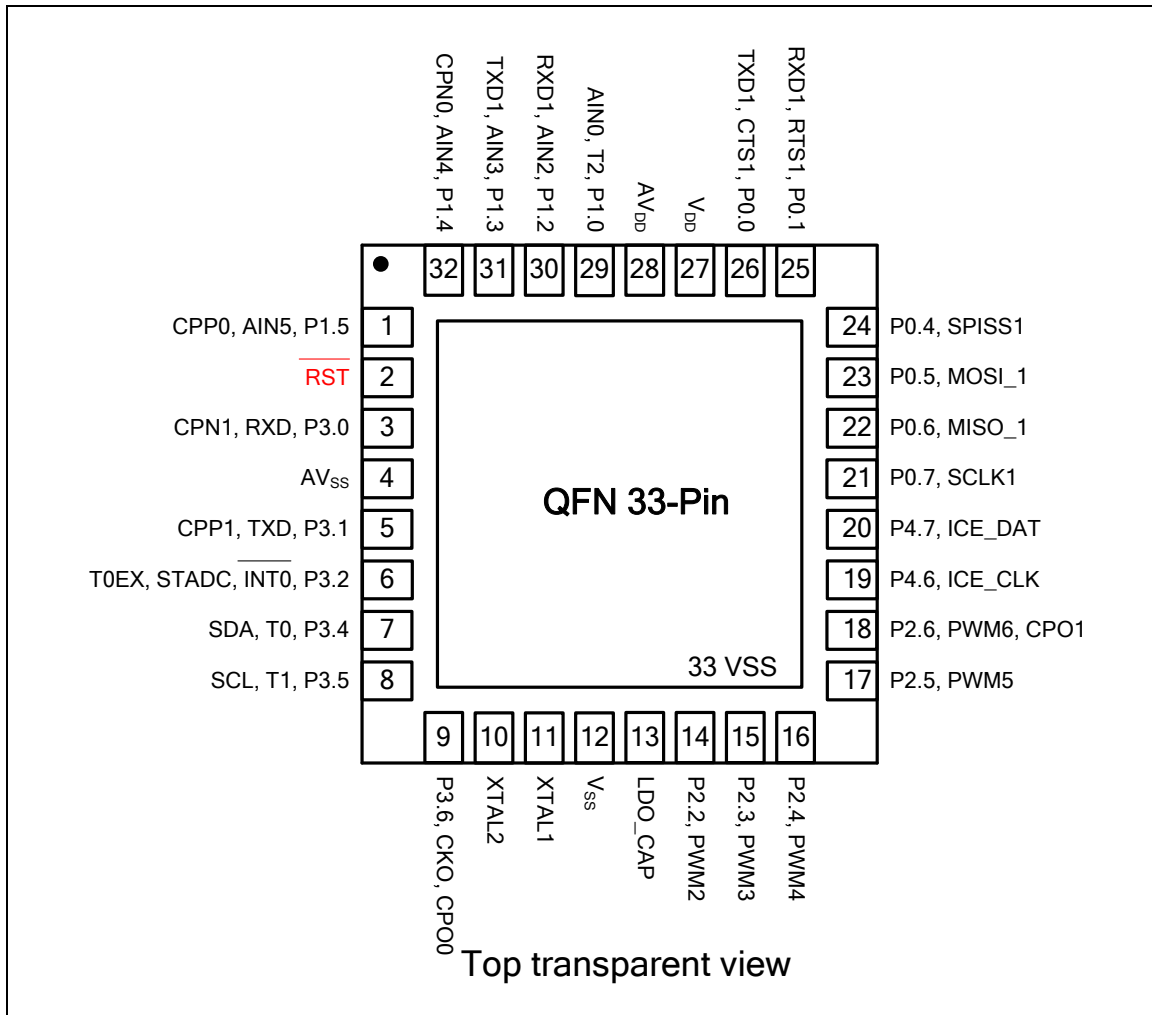

Figure 5-1 NuMicro™ M051 Series QFN33 Pin Diagram



5.2 LQFP 48 pin

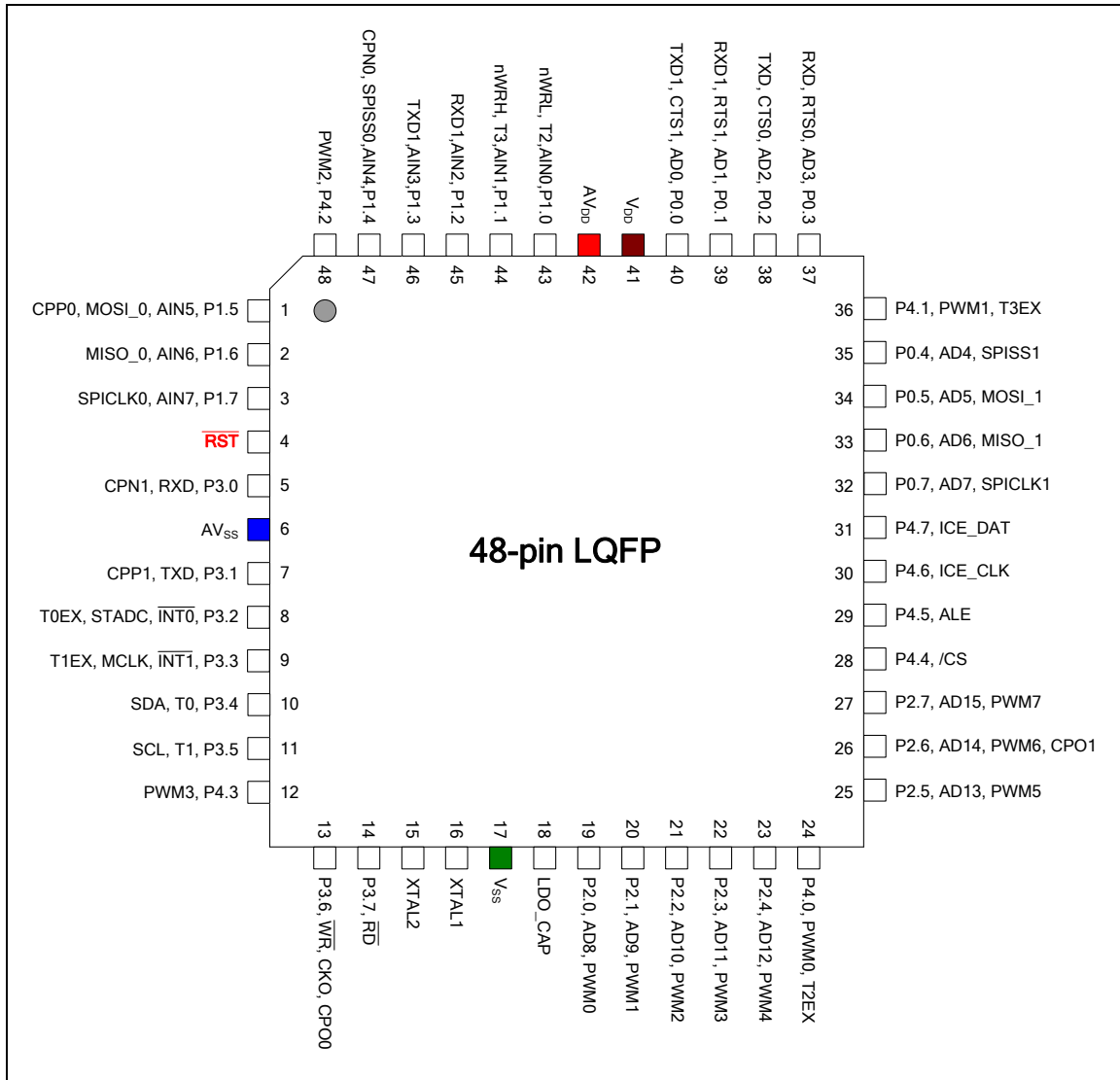

Figure 5-2 NuMicro™ M051 Series LQFP-48 Pin Diagram



5.3 Pin Description

Pin number		Symbol	Alternate Function			Type ⁽¹⁾	Description
QFN33	LQFP48		1	2	3		
11	16	XTAL1				I (ST)	CRYSTAL1: This is the input pin to the internal inverting amplifier. The system clock is from external crystal or resonator when FOSC[1:0] (CONFIG3[1:0]) are both logic 1 by default.
10	15	XTAL2				O	CRYSTAL2: This is the output pin from the internal inverting amplifier. It emits the inverted signal of XTAL1.
27	41	V _{DD}				P	POWER SUPPLY: Power supply to I/O ports and LDO source for internal PLL and digital circuit.
12	17	V _{SS}				P	GROUND: Digital Ground potential.
33							
28	42	AV _{DD}				P	POWER SUPPLY: Power supply to internal analog circuit.
4	6	AV _{SS}				P	GROUND: Analog Ground potential.
13	18	LDO_CAP				P	LDO: LDO output pin Note: It needs to be connected with a 1uF capacitor.
2	4	$\overline{\text{RST}}$				I (ST)	RESET: /RST pin is a Schmitt trigger input pin for hardware device reset. A “Low” on this pin for 768 clock counter of Internal RC 22M while the system clock is running will reset the device. /RST pin has an internal pull-up resistor allowing power-on reset by simply connecting an external capacitor to GND.
26	40	P0.0	CTS1	AD0	TXD1 ^[2]	D, I/O	PORT0: Port 0 is an 8-bit four mode output pin and two mode input. Its multifunction pins are for CTS1, RTS1, CTS0, RTS0, SPISS1, MOSI_1, MISO_1, and SPICLK1. P0 has an alternative function as AD[7:0] while external memory accessing. During the external memory access, P0 will output high will be internal strong pulled-up rather than weak pull-up in order to drive out high byte address for external devices. These pins which are SPISS1, MOSI_1, MISO_1, and SPICLK1 for the SPI function used.
25	39	P0.1	RTS1	AD1	RXD1 ^[2]		
NC	38	P0.2	CTS0	AD2	TXD ^[2]		
NC	37	P0.3	RTS0	AD3	RXD ^[2]		
24	35	P0.4	SPISS1	AD4			



Pin number		Symbol	Alternate Function			Type ⁽¹⁾	Description
QFN33	LQFP48		1	2	3		
						I/O	CTS0/1: Clear to Send input pin for UART0/1 RTS0/1: Request to Send output pin for UART0/1
23	34	P0.5	MOSI_1	AD5		D, I/O	The RXD/TXD pins are for UART0 function used.
22	33	P0.6	MISO_1	AD6		D, I/O	The RXD1/TXD1 pins are for UART1 function used.
21	32	P0.7	SPICLK1	AD7		D, I/O	
29	43	P1.0	T2	AIN0	\overline{WRL}	I/O	PORT1: Port 1 is an 8-bit four mode output pin and two mode input. Its multifunction pins are for T2, T3, RXD1, TXD1, SPISS0, MOSI_0, MISO_0, and SPICLK0.
NC	44	P1.1	T3	AIN1	\overline{WRH}	I/O	These pins which are SPISS0, MOSI_0, MISO_0, and SCLK0 for the SPI function used.
30	45	P1.2	RXD1 ^[3]	AIN2		I/O	These pins which are AIN0~AIN7 for the 12 bits ADC function used.
31	46	P1.3	TXD1 ^[3]	AIN3		I/O	The RXD1/TXD1 pins are for UART1 function used.
32	47	P1.4	SPISS0	AIN4	CPN0	I/O	The \overline{WRL} / \overline{WRH} pins are for low/high byte write enable output in 16-bit data width of EBI.
1	1	P1.5	MOSI_0	AIN5	CPP0	I/O	The CPN0/ CPP0 pins are for Comparator0 negative/positive inputs.
NC	2	P1.6	MISO_0	AIN6		I/O	The T2/T3 pins are for Timer2/3 external even counter input.
NC	3	P1.7	SPICLK0	AIN7		I/O	
NC	19	P2.0	PWM0 ^[2]	AD8		D, I/O	PORT2: Port 2 is an 8-bit four mode output pin and two mode input. It has an alternative function
NC	20	P2.1	PWM1 ^[2]	AD9		D, I/O	P2 has an alternative function as AD[15:8] while external memory accessing. During the external memory access, P2 will output high will be internal strong pulled-up rather than weak pull-up in order to drive out high byte address for external devices.
14	21	P2.2	PWM2 ^[2]	AD10		D, I/O	
15	22	P2.3	PWM3 ^[2]	AD11		D, I/O	These pins which are PWM0~PWM7 for the PWM function used in the LQFP48 package. The CPO1 pin is the output of Comparator1.
16	23	P2.4	PWM4 ^[2]	AD12		D, I/O	
17	25	P2.5	PWM5 ^[2]	AD13		D, I/O	



Pin number		Symbol	Alternate Function			Type ^[1]	Description
QFN33	LQFP48		1	2	3		
18	26	P2.6	PWM6 ^[2]	AD14	CPO1	D, I/O	
NC	27	P2.7	PWM7 ^[2]	AD15		D, I/O	
3	5	P3.0	RXD ^[2]		CPN1	I/O	<p>PORT3: Port 3 is an 8-bit four mode output pin and two mode input. Its multifunction pins are for RXD, TXD, $\overline{\text{INT0}}$, $\overline{\text{INT1}}$, T0, T1, $\overline{\text{WR}}$, and $\overline{\text{RD}}$.</p> <p>The RXD/TXD pins are for UART0 function used.</p> <p>The SDA/SCK pins are for I²C function used.</p> <p>MCLK: EBI clock output pin.</p> <p>CKO: HCLK clock output</p> <p>The STADC pin is for ADC external trigger input.</p> <p>The CPN1/CPP1 pins are for Comparator1 negative/positive inputs.</p> <p>The CPO0 pin is the output of Comparator0.</p> <p>The T0/T1 pins are for Timer0/1 external even counter input.</p> <p>The T0EX/T1EX pins are for external capture/reset trigger input of Timer0/1.</p>
5	7	P3.1	TXD ^[2]		CPP1	I/O	
6	8	P3.2	$\overline{\text{INT0}}$	STADC	T0EX	I/O	
NC	9	P3.3	$\overline{\text{INT1}}$	MCLK	T1EX	I/O	
7	10	P3.4	T0	SDA		I/O	
8	11	P3.5	T1	SCL		I/O	
9	13	P3.6	$\overline{\text{WR}}$	CKO	CPO0	I/O	
NC	14	P3.7	$\overline{\text{RD}}$			I/O	
NC	24	P4.0	PWM0 ^[2]		T2EX	I/O	
NC	36	P4.1	PWM1 ^[2]		T3EX	I/O	
NC	48	P4.2	PWM2 ^[2]			I/O	<p>PORT4: Port 4 is an 8-bit four mode output pin and two mode input. Its multifunction pins are for /CS, ALE, ICE_CLK and ICE_DAT.</p> <p>$\overline{\text{CS}}$ for EBI (External Bus Interface) used.</p> <p>ALE (Address Latch Enable) is used to enable the address latch that separates the address from the data on Port 0 and Port 2.</p> <p>The ICE_CLK/ICE_DAT pins are for JTAG-ICE function used.</p> <p>PWM0-3 can be used from P4.0-P4.3 when EBI is active.</p> <p>The T2EX/T3EX pins are for external capture/reset trigger input of Timer2/3.</p>
NC	12	P4.3	PWM3 ^[2]			I/O	
NC	28	P4.4	$\overline{\text{CS}}$			I/O	
NC	29	P4.5	ALE			I/O	
19	30	P4.6	ICE_CLK			I/O	
20	31	P4.7	ICE_DAT			I/O	

Table 5-1 NuMicro™ M051 Series Pin Description

[1] I/O type description. I: input, O: output, I/O: quasi bi-direction, D: open-drain, P: power pins,

ST: Schmitt trigger.

[2] The pins features which are set by S/W. Only one-set pin can be used while S/W to set it.

6 FUNCTIONAL DESCRIPTION

6.1 ARM® Cortex™-M0 Core

The Cortex™-M0 processor is a configurable, multistage, 32-bit RISC processor. It has an AMBA AHB-Lite interface and includes an NVIC component. It also has optional hardware debug functionality. The processor can execute Thumb code and is compatible with other Cortex-M profile processor. The profile supports two modes -Thread and Handler modes. Handler mode is entered as a result of an exception. An exception return can only be issued in Handler mode. Thread mode is entered on Reset, and can be entered as a result of an exception return. Figure 6-1 shows the functional controller of processor.

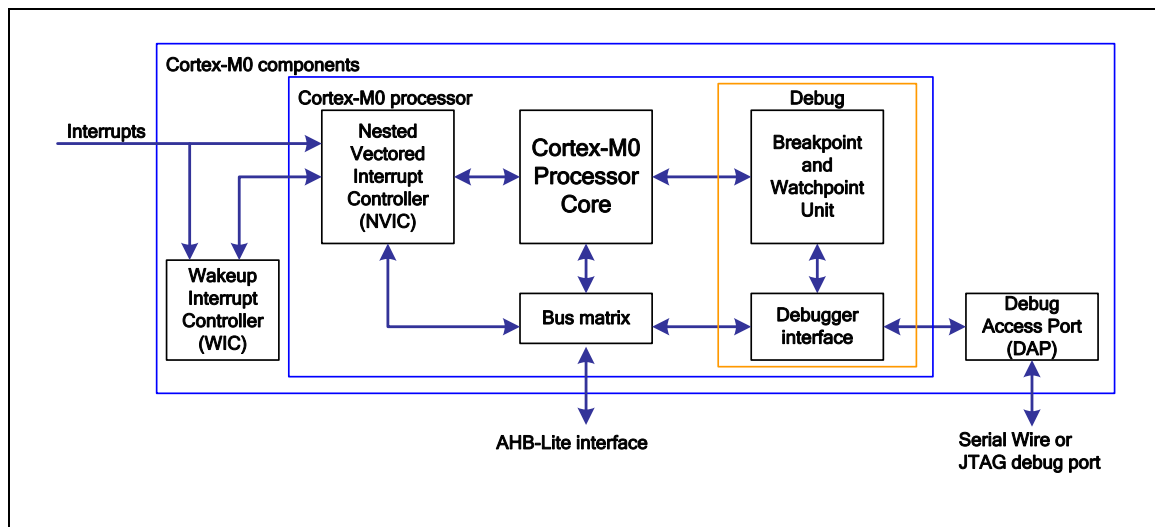

Figure 6-1 Functional Block Diagram

The implemented device provides:

A low gate count processor the features:

- The ARMv6-M Thumb® instruction set.
- Thumb-2 technology.
- ARMv6-M compliant 24-bit SysTick timer.
- A 32-bit hardware multiplier.
- The system interface supports little-endian data accesses.
- The ability to have deterministic, fixed-latency, interrupt handling.
- Load/store-multiples and multicycle-multiplies that can be abandoned and restarted to facilitate rapid interrupt handling.



- C Application Binary Interface compliant exception model.
This is the ARMv6-M, C Application Binary Interface(C-ABI) compliant exception model that enables the use of pure C functions as interrupt handlers.
- Low power sleep-mode entry using Wait For Interrupt (WFI), Wait For Event(WFE) instructions, or the return from interrupt sleep-on-exit feature.

NVIC features:

- 32 external interrupt inputs, each with four levels of priority.
- Dedicated non-Maskable Interrupt (NMI) input.
- Support for both level-sensitive and pulse-sensitive interrupt lines
- Wake-up Interrupt Controller (WIC), supports ultra-low power sleep mode.

Debug support:

- Four hardware breakpoints.
- Two watchpoints.
- Program Counter Sampling Register (PCSR) for non-intrusive code profiling.
- Single step and vector catch capabilities.

Bus interfaces:

- Single 32-bit AMBA-3 AHB-Lite system interface that provides simple integration to all system peripherals and memory.
- Single 32-bit slave port that supports the DAP (Debug Access Port).

6.2 System Manager

6.2.1 Overview

The following functions are included in system manager section

- System Resets
- System Memory Map
- System management registers for Part Number ID, chip reset and on-chip module reset , multi-functional pin control
- System Timer (SysTick)
- Nested Vectored Interrupt Controller (NVIC)
- System Control registers

6.2.2 System Reset

The system reset includes one of the list below event occurs. For these reset event flags can be read by RSTSRC register.

- The Power-On Reset (POR)
- The low level on the /RESET pin
- Watchdog Time Out Reset (WDT)
- Low Voltage Reset (LVR)
- Brown-Out Detected Reset (BOD)
- CPU Reset
- Software one shot Reset

6.2.3 System Power Architecture

In this device, the power architecture is divided into three segments.

- Analog power from AV_{DD} and AV_{SS} provides the power for analog module operation.
- Digital power from V_{DD} and V_{SS} supplies the power to the internal regulator which provides a fixed 1.8V power for digital operation and I/O pins.

The outputs of internal voltage regulator, which is LDO, require an external capacitor which should be located close to the corresponding pin. The Figure 6-2 shows the power architecture of this device.

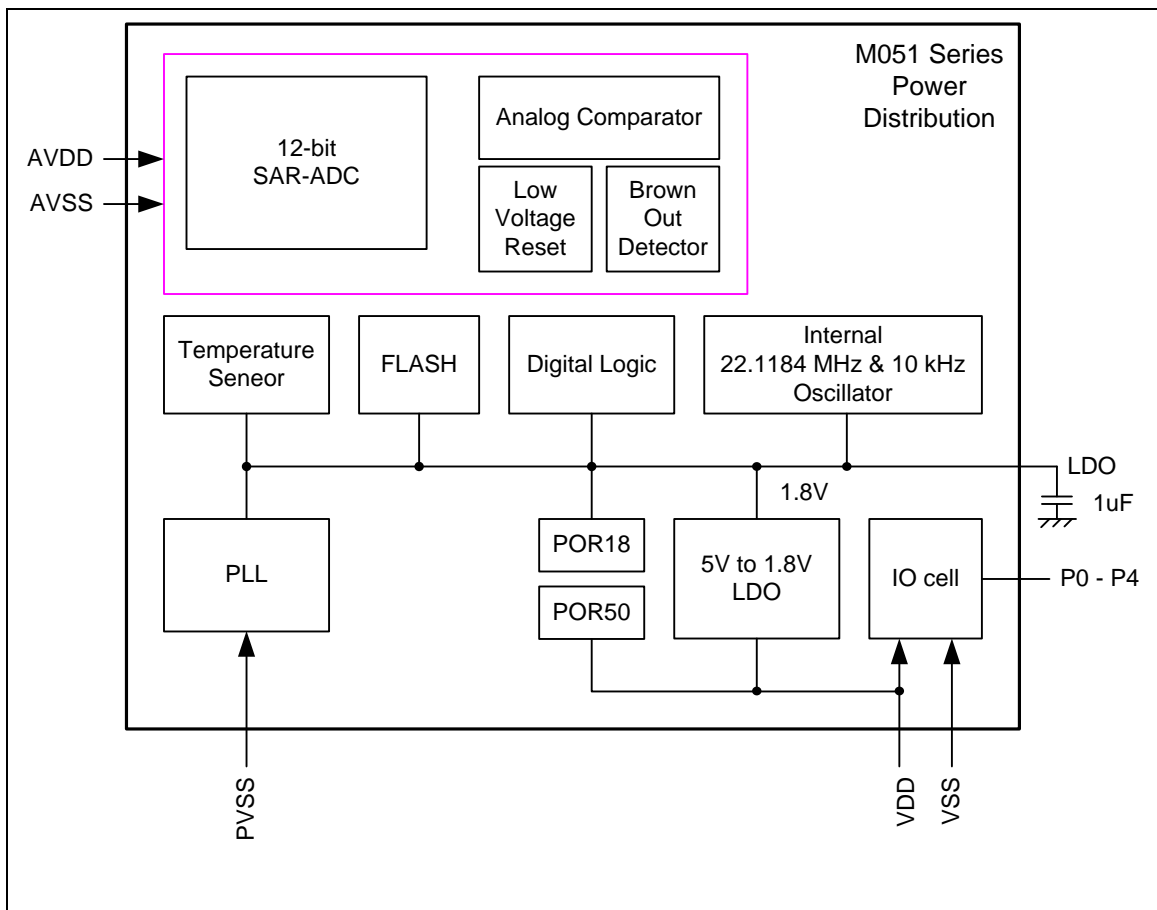

Figure 6-2 NuMicro M051™ Series Power Architecture Diagram



6.2.4 Whole System Memory Map

NuMicro M051™ series provides a 4G-byte address space. The memory locations assigned to each on-chip modules are shown in Table 6-1. The detailed register memory addressing and programming will be described in the following sections for 1 individual on-chip peripherals. NuMicro M051™ series only supports little-endian data format.

Address Space	Token	Modules
Flash & SRAM Memory Space		
0x0000_0000 – 0x0000_FFFF	FLASH_BA	FLASH Memory Space (64KB)
0x2000_0000 – 0x2000_0FFF	SRAM_BA	SRAM Memory Space (4KB)
EBI Space (0x6000_0000 ~ 0x6001_FFFF)		
0x6000_0000 – 0x6001_FFFF	EBI_BA	External Memory Space (128KB)
AHB Modules Space (0x5000_0000 – 0x501F_FFFF)		
0x5000_0000 – 0x5000_01FF	GCR_BA	System Global Control Registers
0x5000_0200 – 0x5000_02FF	CLK_BA	Clock Control Registers
0x5000_0300 – 0x5000_03FF	INT_BA	Interrupt Multiplexer Control Registers
0x5000_4000 – 0x5000_7FFF	GPIO_BA	GPIO (P0~P4) Control Registers
0x5000_C000 – 0x5000_FFFF	FMC_BA	Flash Memory Control Registers
0x5001_0000 – 0x5001_03FF	EBI_CTL_BA	EBI Control Registers (128KB)
APB Modules Space (0x4000_0000 ~ 0x400F_FFFF)		
0x4000_4000 – 0x4000_7FFF	WDT_BA	Watch-Dog Timer Control Registers
0x4001_0000 – 0x4001_3FFF	TMR01_BA	Timer0/Timer1 Control Registers
0x4002_0000 – 0x4002_3FFF	I2C_BA	I ² C Interface Control Registers
0x4003_0000 – 0x4003_3FFF	SPIO_BA	SPIO with master/slave function Control Registers
0x4003_4000 – 0x4003_7FFF	SPI1_BA	SPI1 with master/slave function Control Registers
0x4004_0000 – 0x4004_3FFF	PWMA_BA	PWM0/1/2/3 Control Registers
0x4005_0000 – 0x4005_3FFF	UART0_BA	UART0 Control Registers
0x400D_0000 – 0x400D_3FFF	ACMP_BA	Analog Comparator Control Registers



Address Space	Token	Modules
0x400E_0000 – 0x400E_FFFF	ADC_BA	Analog-Digital-Converter (ADC) Control Registers
0x4011_0000 – 0x4011_3FFF	TMR23_BA	Timer2/Timer3 Control Registers
0x4014_0000 – 0x4014_3FFF	PWMB_BA	PWM4/5/6/7 Control Registers
0x4015_0000 – 0x4015_3FFF	UART1_BA	UART1 Control Registers
System Control Space (0xE000_E000 ~ 0xE000_EFFF)		
0xE000_E010 – 0xE000_E0FF	SCS_BA	System Timer Control Registers
0xE000_E100 – 0xE000_ECFF	SCS_BA	External Interrupt Controller Control Registers
0xE000_ED00 – 0xE000_ED8F	SCS_BA	System Control Registers

Table 6-1 Address Space Assignments for On-Chip Modules

6.2.5 Whole System Memory Mapping Table

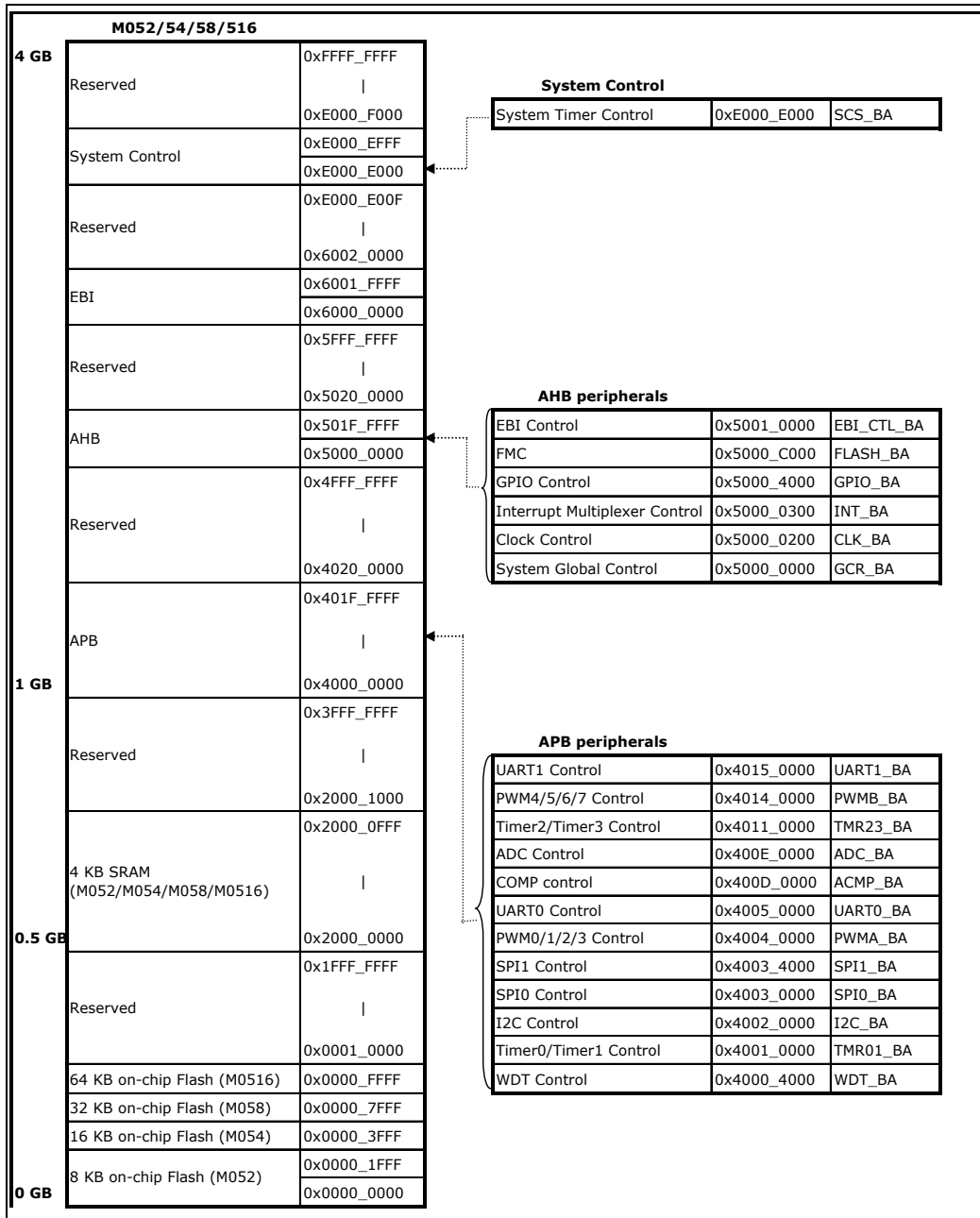

6.2.6 System Timer (SysTick)

The Cortex-M0 includes an integrated system timer, SysTick. SysTick provides a simple, 24-bit clear-on-write, decrementing, wrap-on-zero counter with a flexible control mechanism. The counter can be used as a Real Time Operating System (RTOS) tick timer or as a simple counter.

When system timer is enabled, it will count down from the value in the SysTick Current Value



Register (SYST_CVR) to zero, and reload (wrap) to the value in the SysTick Reload Value Register (SYST_RVR) on the next clock edge, then decrement on subsequent clocks. When the counter transitions to zero, the COUNTFLAG status bit is set. The COUNTFLAG bit clears on reads.

The SYST_CVR value is UNKNOWN on reset. Software should write to the register to clear it to zero before enabling the feature. This ensures the timer will count from the SYST_RVR value rather than an arbitrary value when it is enabled.

If the SYST_RVR is zero, the timer will be maintained with a current value of zero after it is reloaded with this value. This mechanism can be used to disable the feature independently from the timer enable bit.

For more detailed information, please refer to the documents “ARM® Cortex™-M0 Technical Reference Manual” and “ARM® v6-M Architecture Reference Manual”.

6.2.7 Nested Vectored Interrupt Controller (NVIC)

Cortex-M0 provides an interrupt controller as an integral part of the exception mode, named as “Nested Vectored Interrupt Controller (NVIC)”. It is closely coupled to the processor kernel and provides following features:

- Nested and Vectored interrupt support
- Automatic processor state saving and restoration
- Dynamic priority changing
- Reduced and deterministic interrupt latency

The NVIC prioritizes and handles all supported exceptions. All exceptions are handled in “Handler Mode”. This NVIC architecture supports 32 (IRQ[31:0]) discrete interrupts with 4 levels of priority. All of the interrupts and most of the system exceptions can be configured to different priority levels. When an interrupt occurs, the NVIC will compare the priority of the new interrupt to the current running one’s priority. If the priority of the new interrupt is higher than the current one, the new interrupt handler will override the current handler.

When any interrupts is accepted, the starting address of the interrupt service routine (ISR) is fetched from a vector table in memory. There is no need to determine which interrupt is accepted and branch to the starting address of the correlated ISR by software. While the starting address is fetched, NVIC will also automatically save processor state including the registers “PC, PSR, LR, R0~R3, R12” to the stack. At the end of the ISR, the NVIC will restore the mentioned registers from stack and resume the normal execution. Thus it will take less and deterministic time to process the interrupt request.

The NVIC supports “Tail Chaining” which handles back-to-back interrupts efficiently without the overhead of states saving and restoration and therefore reduces delay time in switching to pending ISR at the end of current ISR. The NVIC also supports “Late Arrival” which improves the efficiency of concurrent ISRs. When a higher priority interrupt request occurs before the current ISR starts to execute (at the stage of state saving and starting address fetching), the NVIC will give priority to the higher one without delay penalty. Thus it advances the real-time capability.

For more detailed information, please refer to the documents “ARM® Cortex™-M0 Technical Reference Manual” and “ARM® v6-M Architecture Reference Manual”.

6.3 Clock Controller

6.3.1 Overview

The clock controller generates the clocks for the whole chip, including system clocks and all peripheral clocks. The clock controller also implements the power control function with the individually clock ON/OFF control, clock source selection and clock divider. The chip will not enter power-down mode until CPU sets the power down enable bit (PWR_DOWN_EN) and Cortex-M0 core executes the WFI instruction. After that, chip enter power-down mode and wait for wake-up interrupt source triggered to leave power-down mode. In the power down mode, the clock controller turns off the external crystal and internal 22.1184 MHz oscillator to reduce the overall system power consumption.

6.3.2 Clock Generator Block Diagram

The clock generator consists of 4 sources which list below:

- One external 4~24 MHz crystal
- One internal 22.1184 MHz RC oscillator
- One programmable PLL FOUT(PLL source consists of external 4~24 MHz crystal and internal 22.1184M)
- One internal 10 kHz oscillator

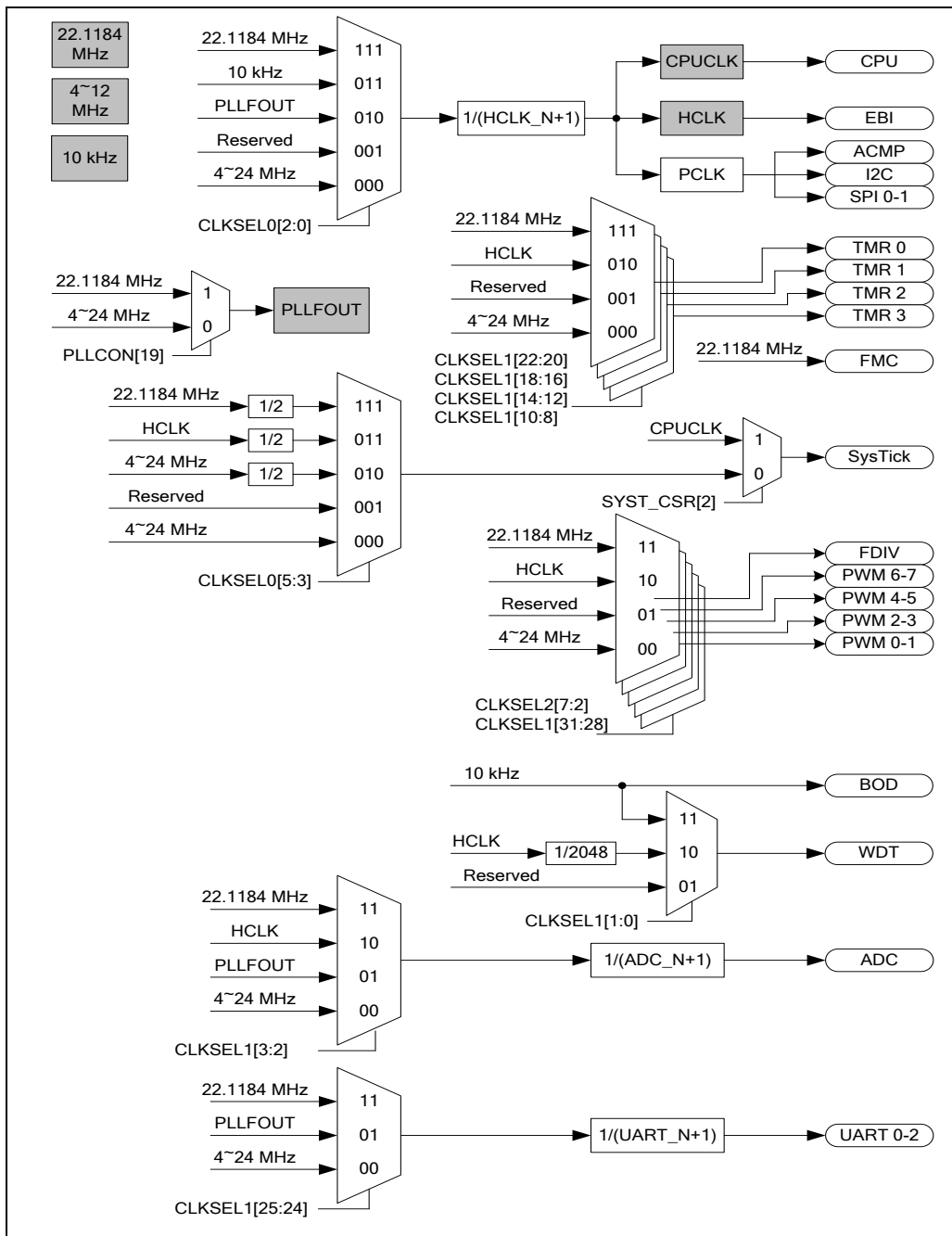

Figure 6-3 Clock generator block diagram

6.3.3 System Clock & SysTick Clock

The system clock has 4 clock sources which were generated from clock generator block. The clock source switch depends on the register HCLK_S(CLKSEL0[2:0]). The block diagram is shown in the Figure 6-4.

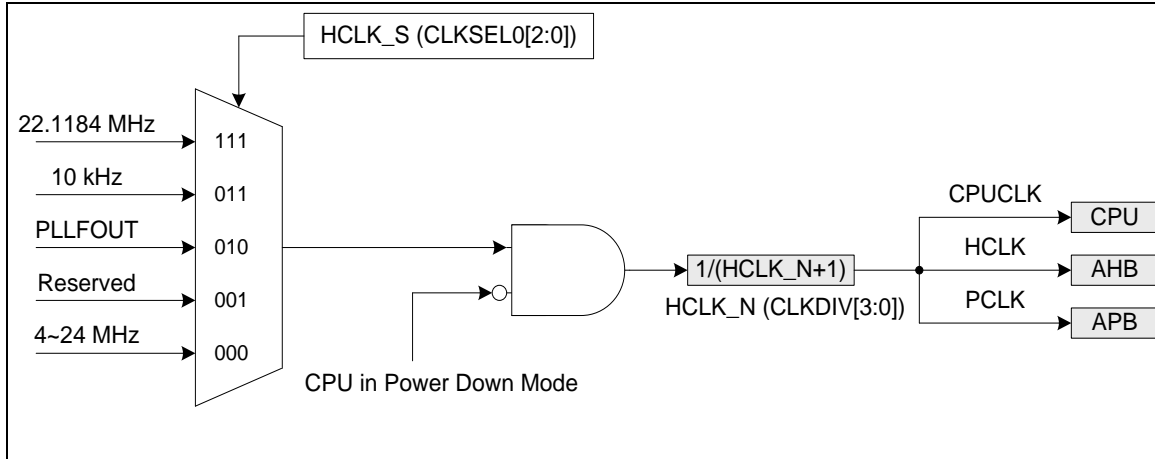

Figure 6-4 System Clock Block Diagram

The clock source of SysTick in Cortex-M0 core can use CPU clock or external clock (SYST_CSR[2]). If using external clock, the SysTick clock (STCLK) has 4 clock sources. The clock source switch depends on the setting of the register STCLK_S (CLKSEL0[5:3]). The block diagram is shown in the Figure 6-5.

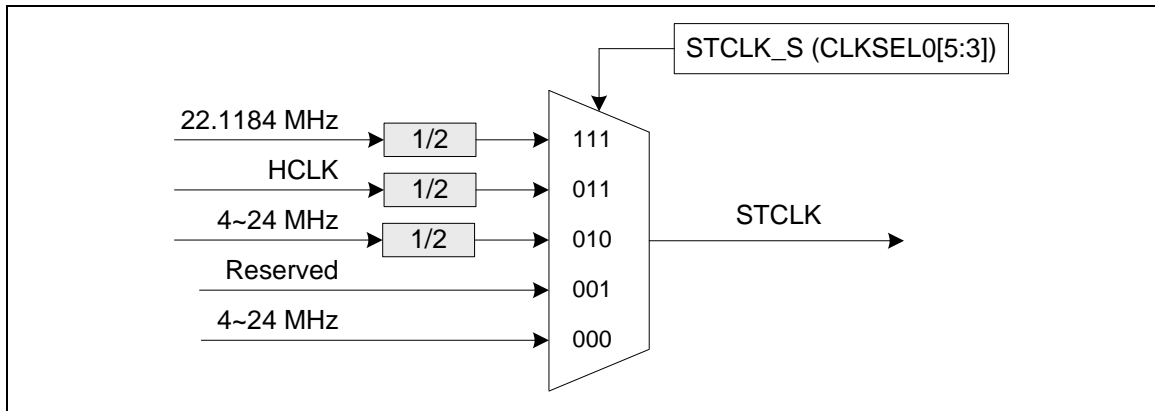

Figure 6-5 SysTick clock Control Block Diagram

6.3.4 AHB Clock Source Select

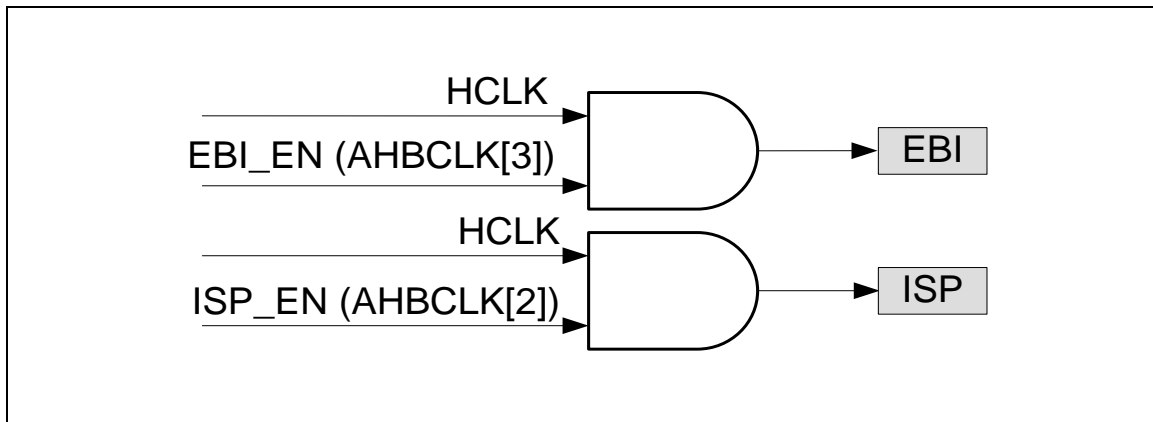

Figure 6-6 AHB Clock Source for HCLK

6.3.5 Peripherals Clock Source Select

The peripherals clock had different clock source switch setting which depends on the different peripheral.

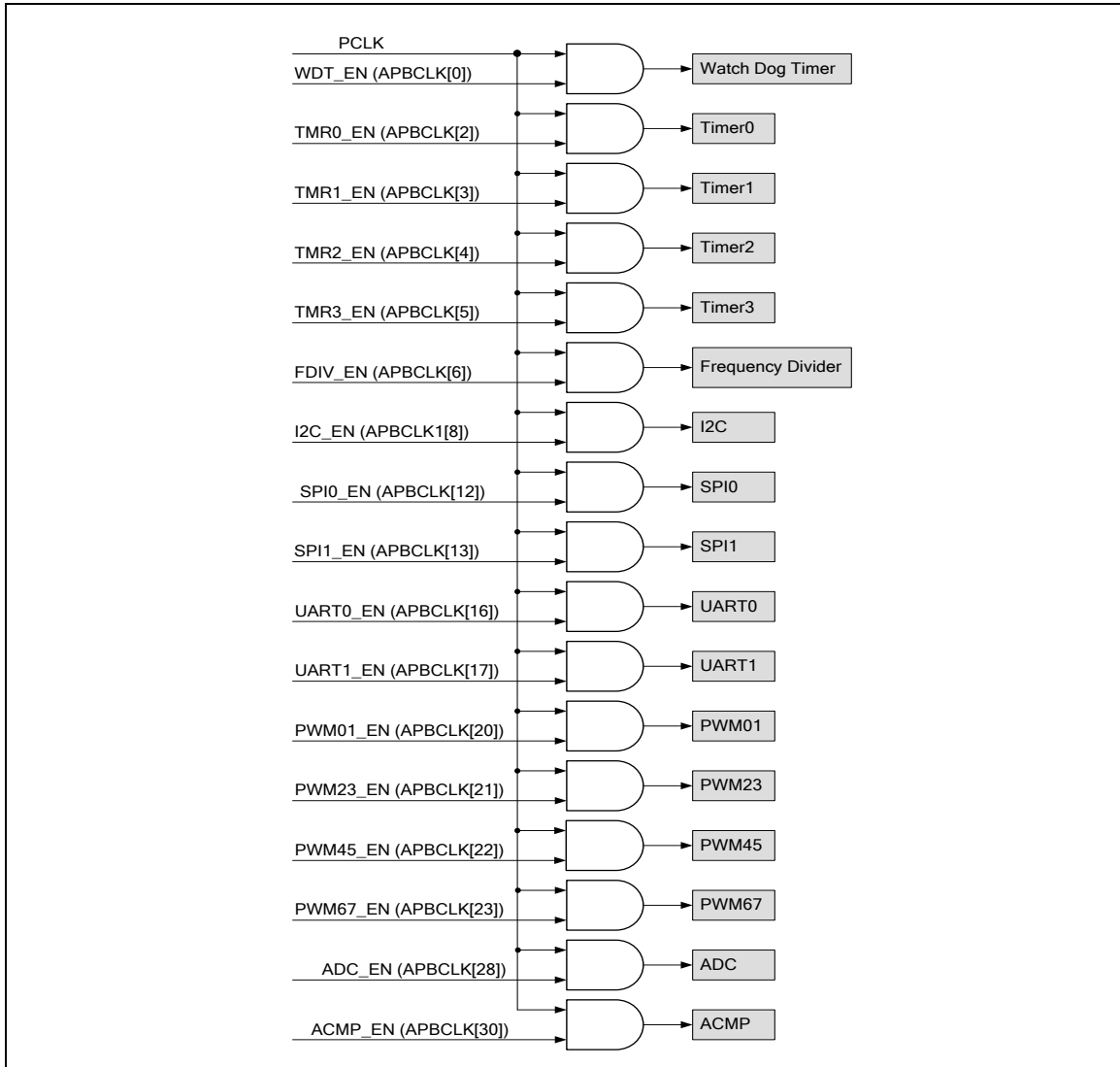

Figure 6-7 Peripherals Clock Source Select for PCLK

6.3.6 Power Down Mode (Deep Sleep Mode) Clock

When chip enter into power down mode, most of clock sources, peripheral clocks and system clock will be disabled directly. Internal 10kHz could be still active in power down/deep power down mode if CPU does not disable it before entering power down mode. IP engine clock could be still active in power down/deep power down mode if IP adopts internal 10kHz does not be disabled respectively.

6.3.7 Frequency Divider Output

This device is equipped a power-of-2 frequency divider which is composed by 16 chained divide-by-2 shift registers. One of the 16 shift register outputs selected by a sixteen to one multiplexer is reflected to P3.6. Therefore there are 16 options of power-of-2 divided clocks with the frequency from $F_{in}/2^1$ to $F_{in}/2^{17}$ where F_{in} is input clock frequency to the clock divider.

The output formula is $F_{out} = F_{in}/2^{(N+1)}$, where F_{in} is the input clock frequency, F_{out} is the clock divider output frequency and N is the 4-bit value in FREQDIV.FSEL[3:0].

When write 1 to DIVIDER_EN (FRQDIV[4]), the chained counter starts to count. When write 0 to DIVIDER_EN (FRQDIV[4]), the chained counter continuously runs till divided clock reaches low state and stay in low state.

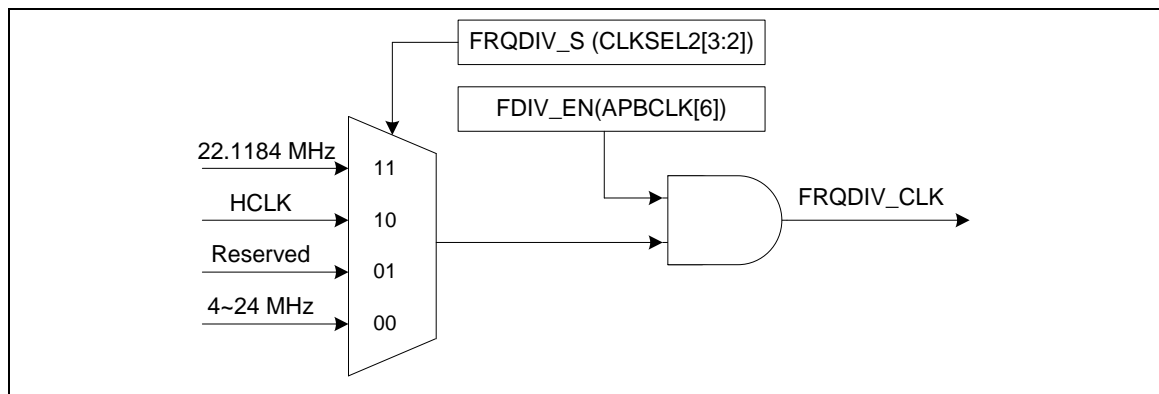

Figure 6-8 Clock Source of Frequency Divider

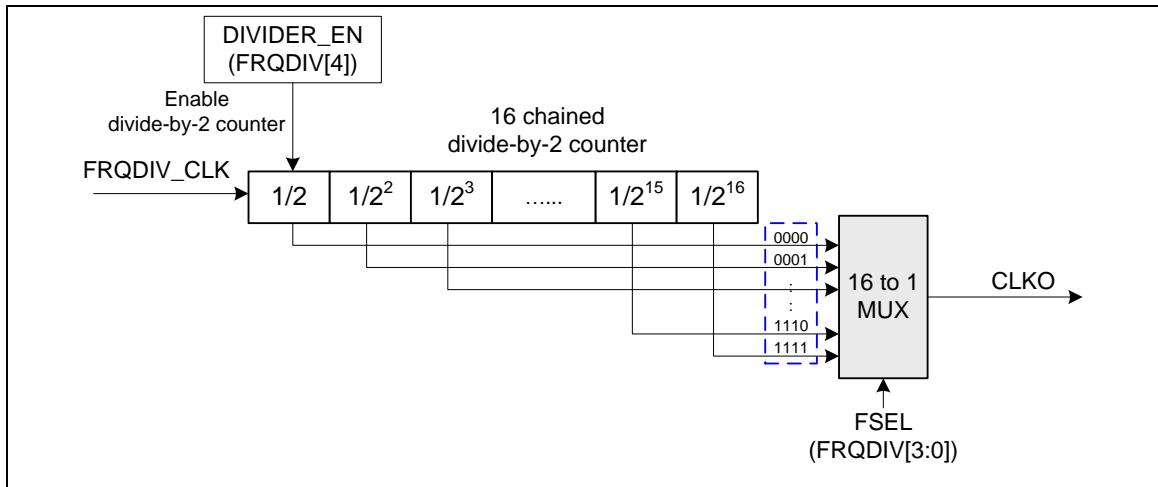

Figure 6-9 Block Diagram of Frequency Divider

6.4 General Purpose I/O

6.4.1 Overview

There are 40 General Purpose I/O pins shared with special feature functions in this MCU. The 40 pins are arranged in 5 ports named with P0, P1, P2, P3 and P4. Each port equips maximum 8 pins. Each one of the 40 pins is independent and has the corresponding register bits to control the pin mode function and data

The I/O type of each of I/O pins can be software configured individually as input, output, open-drain or quasi-bidirectional mode. The all pins of I/O type stay in quasi-bidirectional mode and port data register Px_DOUT[7:0] resets to 0x000_00FF. Each I/O pin equips a very weakly individual pull-up resistor which is about 110KΩ~300KΩ for V_{DD} is from 5.0V to 2.5V.

6.4.1.1 Input Mode Explanation

Set Px_PMD(PMDn[1:0]) to 00b the Px[n] pin is in Input mode and the I/O pin is in tri-state(high impedance) without output drive capability. The Px_PIN value reflects the status of the corresponding port pins.

6.4.1.2 Output Mode Explanation

Set Px_PMD(PMDn[1:0]) to 2'b01 the Px[n] pin is in Output mode and the I/O pin supports digital output function with source/sink current capability. The bit value in the corresponding bit [n] of Px_DOUT is driven on the pin.

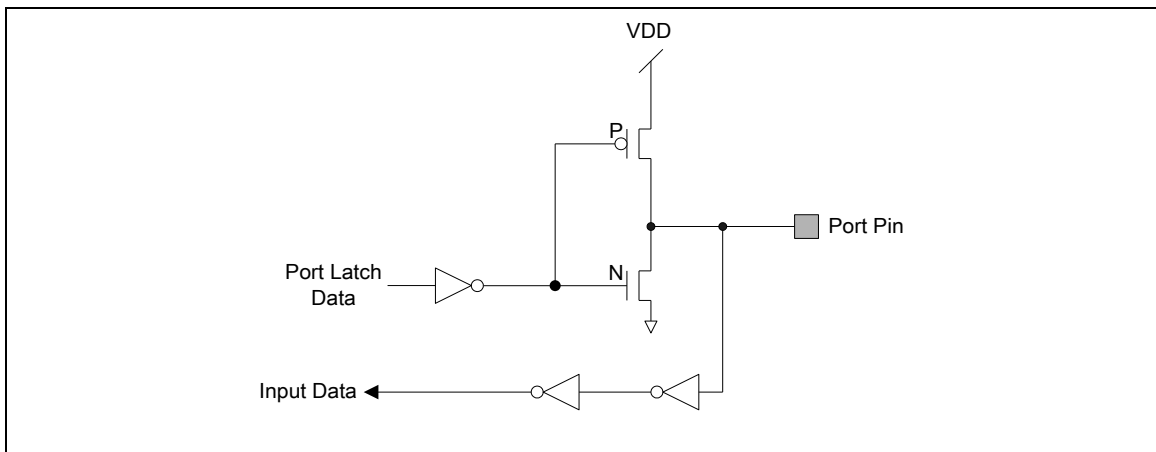

Figure 6-10 Push-Pull Output

6.4.1.3 Open-Drain Mode Explanation

Set $Px_PMD(PMDn[1:0])$ to 2'b10 the $Px[n]$ pin is in Open-Drain mode and the I/O pin supports digital output function but only with sink current capability, an additional pull-up resistor is needed for driving high state. If the bit value in the corresponding bit [n] of Px_DOUT is "0", the pin drive a "low" output on the pin. If the bit value in the corresponding bit [n] of Px_DOUT is "1", the pin output drives high that is controlled by the internal pull-up resistor or the external pull high resistor.

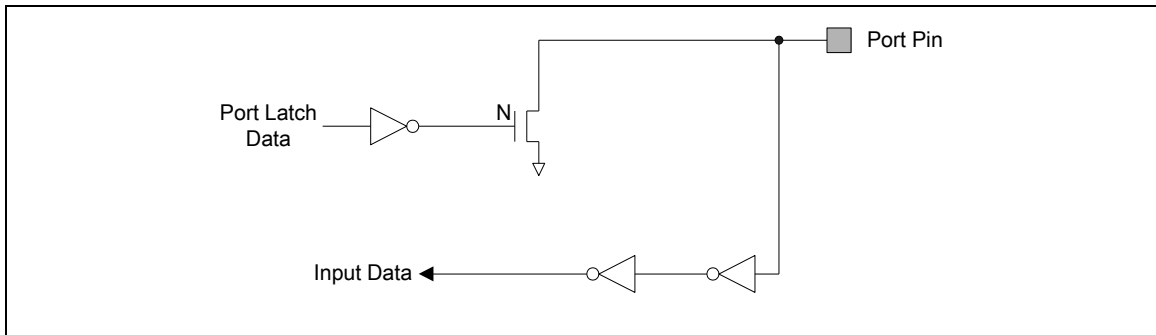

Figure 6-11 Open-Drain Output

6.4.1.4 Quasi-bidirectional Mode Explanation

Set $Px_PMD(PMDn[1:0])$ to 2'b11 the $Px[n]$ pin is in Quasi-bidirectional mode and the I/O pin supports digital output and input function at the same time but the source current is only up to hundreds uA. Before the digital input function is performed the corresponding bit in Px_DOUT must be set to 1. The quasi-bidirectional output is common on the 80C51 and most of its derivatives. If the bit value in the corresponding bit [n] of Px_DOUT is "0", the pin drive a "low" output on the pin. If the bit value in the corresponding bit [n] of Px_DOUT is "1", the pin will check the pin value. If pin value is high, no action takes. If pin state is low, then pin will drive strong high with 2 clock cycles on the pin and then disable the strong output drive and then the pin status is control by internal pull-up resistor. Note that the source current capability in quasi-bidirectional mode is only about 200uA to 30uA for V_{DD} is form 5.0V to 2.5V

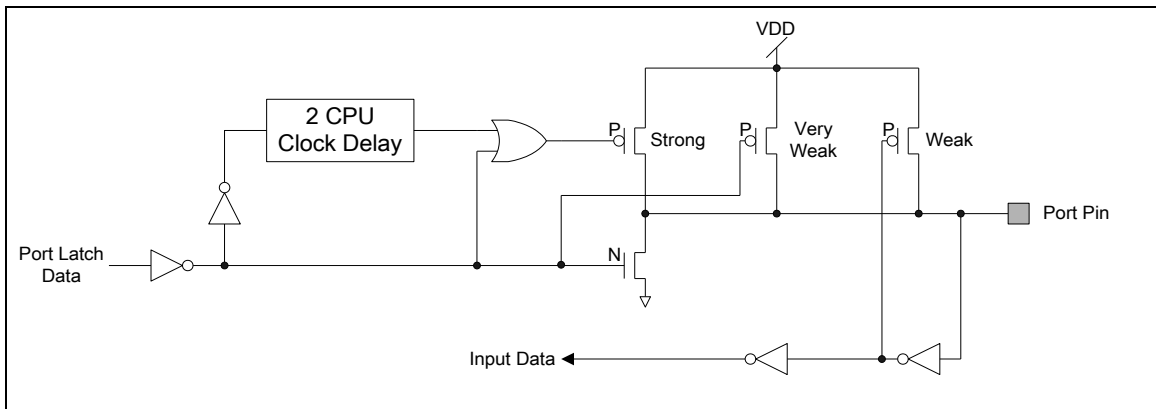

Figure 6-12 Quasi-bidirectional I/O Mode

6.5 I²C Serial Interface Controller (Master/Slave)

6.5.1 Overview

I²C is a two-wire, bi-directional serial bus that provides a simple and efficient method of data exchange between devices. The I²C standard is a true multi-master bus including collision detection and arbitration that prevents data corruption if two or more masters attempt to control the bus simultaneously.

Data is transferred between a Master and a Slave synchronously to SCL on the SDA line on a byte-by-byte basis. Each data byte is 8 bits long. There is one SCL clock pulse for each data bit with the MSB being transmitted first. An acknowledge bit follows each transferred byte. Each bit is sampled during the high period of SCL; therefore, the SDA line may be changed only during the low period of SCL and must be held stable during the high period of SCL. A transition on the SDA line while SCL is high is interpreted as a command (START or STOP). Please refer to the Figure 6-13 for more detail I²C BUS Timing.

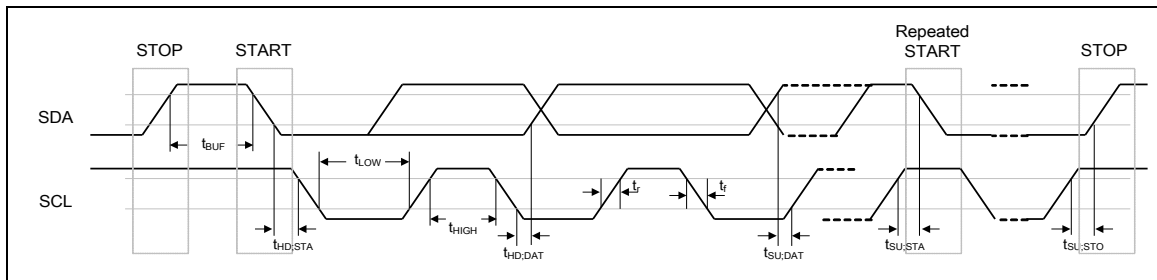

Figure 6-13 I²C Bus Timing

The device's on-chip I²C provides the serial interface that meets the I²C bus standard mode specification. The I²C port handles byte transfers autonomously. To enable this port, the bit ENS1 in I2CON should be set to '1'. The I²C H/W interfaces to the I²C bus via two pins: SDA (serial data line) and SCL (serial clock line). Pull up resistor is needed on pin SDA and SCL for I²C operation as these are open drain pins. When the I/O pins are used as I²C port, user must set the pins function to I²C in advance.

6.5.2 Features

The I²C bus uses two wires (SDA and SCL) to transfer information between devices connected to the bus. The main features of the bus are:

- Support Master and Slave mode
- Bidirectional data transfer between masters and slaves
- Multi-master bus (no central master)
- Arbitration between simultaneously transmitting masters without corruption of serial data on the bus
- Serial clock synchronization allows devices with different bit rates to communicate via one serial bus
- Serial clock synchronization can be used as a handshake mechanism to suspend and resume serial transfer
- Built-in a 14-bit time-out counter will request the I²C interrupt if the I²C bus hangs up and timer-out counter overflows.
- External pull-up are needed for high output
- Programmable clocks allow versatile rate control
- Supports 7-bit addressing mode
- I²C-bus controllers support multiple address recognition (Four slave address with mask option)



6.6 PWM Generator and Capture Timer

6.6.1 Overview

NuMicro M051™ series has 2 sets of PWM group supports 4 sets of PWM Generators which can be configured as 8 independent PWM outputs, PWM0~PWM7, or as 4 complementary PWM pairs, (PWM0, PWM1), (PWM2, PWM3), (PWM4, PWM5) and (PWM6, PWM7) with 4 programmable dead-zone generators.

Each PWM Generator has one 8-bit prescaler, one clock divider with 5 divided frequencies (1, 1/2, 1/4, 1/8, 1/16), two PWM Timers including two clock selectors, two 16-bit PWM down-counters for PWM period control, two 16-bit comparators for PWM duty control and one dead-zone generator. The 4 sets of PWM Generators provide eight independent PWM interrupt flags which are set by hardware when the corresponding PWM period down counter reaches zero. Each PWM interrupt source with its corresponding enable bit can cause CPU to request PWM interrupt. The PWM generators can be configured as one-shot mode to produce only one PWM cycle signal or auto-reload mode to output PWM waveform continuously.

When PCR.DZEN01 is set, PWM0 and PWM1 perform complementary PWM paired function; the paired PWM timing, period, duty and dead-time are determined by PWM0 timer and Dead-zone generator 0. Similarly, the complementary PWM pairs of (PWM2, PWM3), (PWM4, PWM5) and (PWM6, PWM7) are controlled by PWM2, PWM4 and PWM6 timers and Dead-zone generator 2, 4 and 6, respectively. Refer to figures bellowed for the architecture of PWM Timers.

When the 16-bit period down counter reaches zero, the interrupt request is generated. If PWM-timer is set as auto-reload mode, when the down counter reaches zero, it is reloaded with PWM Counter Register (CNRx) automatically then start decreasing, repeatedly. If the PWM-timer is set as one-shot mode, the down counter will stop and generate one interrupt request when it reaches zero.

The value of PWM counter comparator is used for pulse high width modulation. The counter control logic changes the output to high level when down-counter value matches the value of compare register.

The alternate feature of the PWM-timer is digital input Capture function. If Capture function is enabled the PWM output pin is switched as capture input mode. The Capture0 and PWM0 share one timer which is included in PWM 0; and the Capture1 and PWM1 share PWM1 timer, and etc. Therefore user must setup the PWM-timer before enable Capture feature. After capture feature is enabled, the capture always latched PWM-counter to Capture Rising Latch Register (CRLR) when input channel has a rising transition and latched PWM-counter to Capture Falling Latch Register (CFLR) when input channel has a falling transition. Capture channel 0 interrupt is programmable by setting CCR0.CRL_IE0[1] (Rising latch Interrupt enable) and CCR0.CFL_IE0[2] (Falling latch Interrupt enable) to decide the condition of interrupt occur. Capture channel 1 has the same feature by setting CCR0.CRL_IE1[17] and CCR0.CFL_IE1[18]. And capture channel 0 to channel 3 on each group have the same feature by setting the corresponding control bits in CCR0 and CCR2. For each group, whenever Capture issues Interrupt 0/1/2/3, the PWM counter 0/1/2/3 will be reload at this moment.

The maximum captured frequency that PWM can capture is confined by the capture interrupt latency. When capture interrupt occurred, software will do at least three steps, they are: Read PIIR to get interrupt source and Read PWM_CRLx/PWM_CFLx(x=0 and 3) to get capture value and finally write 1 to clear PIIR. If interrupt latency will take time T0 to finish, the capture signal mustn't transition during this interval (T0). In this case, the maximum capture frequency will be



1/T0. For example:

HCLK = 50 MHz, PWM_CLK = 25 MHz, Interrupt latency is 900 ns

So the maximum capture frequency will be $1/900\text{ns} \approx 1000 \text{ kHz}$

6.6.2 Features

6.6.2.1 PWM function features:

PWM group has two PWM generators. Each PWM generator supports one 8-bit prescaler, one clock divider, two PWM-timers (down counter), one dead-zone generator and two PWM outputs.

- Up to 16 bits resolution
- PWM Interrupt request synchronized with PWM period
- One-shot or Auto-reload mode PWM
- Up to 2 PWM group (PWMA/PWMB) to support 8 PWM channels

6.6.2.2 Capture Function Features:

- Timing control logic shared with PWM Generators
- 8 capture input channels shared with 8 PWM output channels
- Each channel supports one rising latch register (CRLR), one falling latch register (CFLR) and Capture interrupt flag (CAPIFx)

6.7 Serial Peripheral Interface (SPI)

6.7.1 Overview

The Serial Peripheral Interface (SPI) is a synchronous serial data communication protocol which operates in full duplex mode. Devices communicate in master/slave mode with 4-wire bi-direction interface. NuMicro M051™ series contains up to two sets of SPI controller performing a serial-to-parallel conversion on data received from a peripheral device, and a parallel-to-serial conversion on data transmitted to a peripheral device. Each set of SPI controller can be set as a master, it also can be configured as a slave device controlled by an off-chip master device. This controller supports a variable serial clock for special application.

6.7.2 Features

- Up to two sets of SPI controller
- Support master or slave mode operation
- Configurable bit length up to 32-bit of a transfer word and configurable word numbers up to 2 of a transaction, so the maximum bit length is 64-bit for each data transfer
- Provide burst mode operation, transmit/receive can be transferred up to two times word transaction in one transfer
- Support MSB or LSB first transfer
- Support byte reorder function
- Support byte or word suspend mode
- Support two programmable serial clock frequencies in master mode
- Support three wire, no slave select signal, bi-direction interface
- The SPI clock rate can be configured to equal the system clock rate

6.8 Timer Controller

6.8.1 Overview

NuMicro M051™ series timer controller includes four 32-bit timers, which allows user to easily implement a timer control for applications. The timer can perform functions like frequency measurement, event counting, interval measurement, clock generation, delay timing, and so on. The timer can generate an interrupt signal upon timeout, or provide the current counting value during operation.

6.8.2 Features:

- 4 sets of 32-bit timers with 24-bit up-timer and one 8-bit pre-scale counter
- Independent clock source for each timer
- Provides one-shot, periodic, toggle and continuous counting operation modes
- Time out period = (Period of timer clock input) * (8-bit pre-scale counter + 1) * (24-bit TCMP)
- Maximum counting cycle time = $(1 / T \text{ MHz}) * (2^8) * (2^{24})$, T is the period of timer clock
- 24-bit timer value is readable through TDR (Timer Data Register)
- Support event counting function to count the event from external pin
- Support input capture function to capture or reset counter value



6.9 Watchdog Timer (WDT)

6.9.1 Overview

The purpose of Watchdog Timer is to perform a system reset when system runs into an unknown state. This prevents system from hanging for an infinite period of time. Besides, this Watchdog Timer supports another function to wakeup chip from power down mode. The watchdog timer includes an 18-bit free running counter with programmable time-out intervals. Table 6-2 show the watchdog timeout interval selection and Figure 6.9-1 shows the timing of watchdog interrupt signal and reset signal.

Setting WTE (WDTCR [7]) enables the watchdog timer and the WDT counter starts counting up. When the counter reaches the selected time-out interval, Watchdog timer interrupt flag WTIF will be set immediately to request a WDT interrupt if the watchdog timer interrupt enable bit WTIE is set, in the meanwhile, a specified delay time ($1024 * T_{WDT}$) follows the time-out event. User must set WTR (WDTCR [0]) (Watchdog timer reset) high to reset the 18-bit WDT counter to avoid chip from Watchdog timer reset before the delay time expires. WTR bit is cleared automatically by hardware after WDT counter is reset. There are eight time-out intervals with specific delay time which are selected by Watchdog timer interval select bits WTIS (WDTCR [10:8]). If the WDT counter has not been cleared after the specific delay time expires, the watchdog timer will set Watchdog Timer Reset Flag (WTRF) high and reset chip. This reset will last 63 WDT clocks (T_{RST}) then chip restarts executing program from reset vector (0x0000 0000). WTRF will not be cleared by Watchdog reset. User may poll WTRF by software to recognize the reset source. WDT also provides wakeup function. When chip is powered down and the Watchdog Timer Wake-up Function Enable bit (WDTR[4]) is set, if the WDT counter reaches the specific time interval defined by WTIS (WDTCR [10:8]), the chip is waken up from power down state. First example, if WTIS is set as 000, the specific time interval for chip to wake up from power down state is $2^4 * T_{WDT}$. When power down command is set by software, then, chip enters power down state. After $2^4 * T_{WDT}$ time is elapsed, chip is waken up from power down state. Second example, if WTIS (WDTCR [10:8]) is set as 111, the specific time interval for chip to wake up from power down state is $2^{18} * T_{WDT}$. If power down command is set by software, then, chip enters power down state. After $2^{18} * T_{WDT}$ time is elapsed, chip is waken up from power down state. Notice if WTRE (WDTCR [1]) is set to 1, after chip is waken up, software should chip the Watchdog Timer counter by setting WTR(WDTCR [0]) to 1 as soon as possible. Otherwise, if the Watchdog Timer counter is not cleared by setting WTR (WDTCR [0]) to 1 before time starting from waking up to software clearing Watchdog Timer counter is over $1024 * T_{WDT}$, the chip is reset by Watchdog Timer.

WTIS	Timeout Interval Selection	Interrupt Period	WTR Timeout Interval (WDT_CLK=10 kHz)
	T_{TIS}	T_{INT}	MIN. T_{WTR} ~ MAX. T_{WTR}
000	$2^4 * T_{WDT}$	$1024 * T_{WDT}$	1.6 ms ~ 104 ms
001	$2^6 * T_{WDT}$	$1024 * T_{WDT}$	6.4 ms ~ 108.8 ms
010	$2^8 * T_{WDT}$	$1024 * T_{WDT}$	25.6 ms ~ 128 ms
011	$2^{10} * T_{WDT}$	$1024 * T_{WDT}$	102.4 ms ~ 204.8 ms
100	$2^{12} * T_{WDT}$	$1024 * T_{WDT}$	409.6 ms ~ 512 ms
101	$2^{14} * T_{WDT}$	$1024 * T_{WDT}$	1.6384 s ~ 1.7408 s
110	$2^{16} * T_{WDT}$	$1024 * T_{WDT}$	6.5536 s ~ 6.656 s
111	$2^{18} * T_{WDT}$	$1024 * T_{WDT}$	26.2144 s ~ 26.3168 s

Table 6-2 Watchdog Timeout Interval Selection

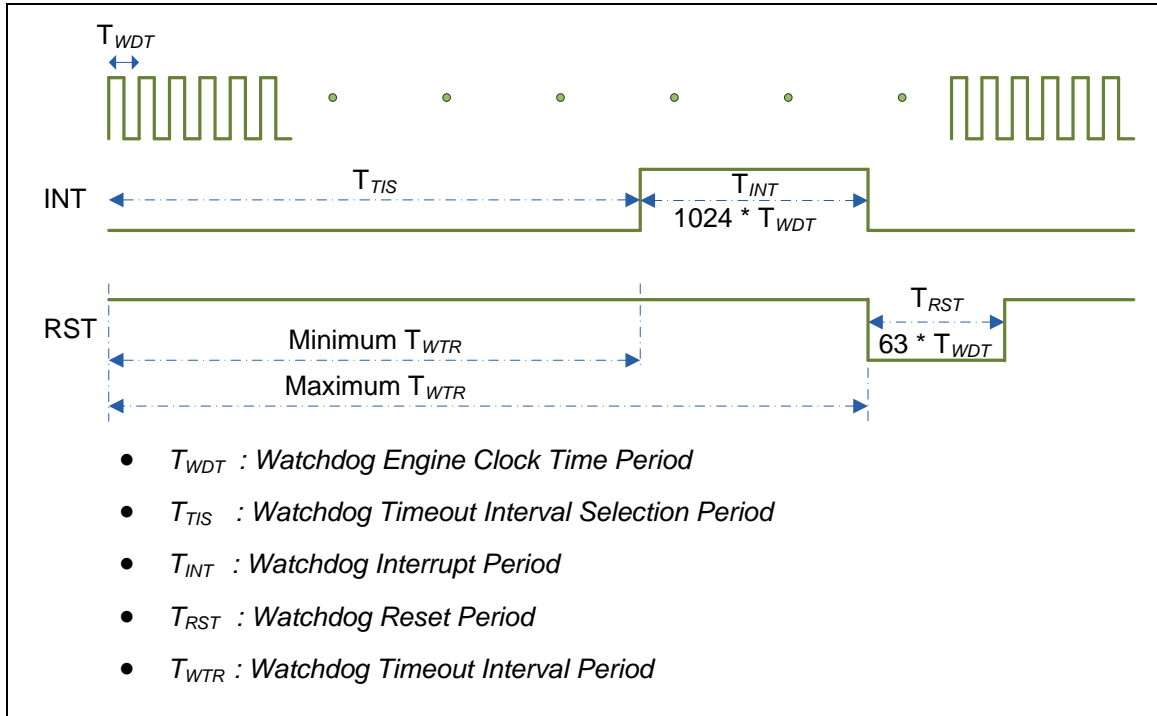

Figure 6-14 Timing of Interrupt and Reset Signal

6.9.2 Features

- 18-bit free running counter to avoid chip from Watchdog timer reset before the delay time expires.
- Selectable time-out interval ($2^4 \sim 2^{18}$) and the time out interval is 104 ms ~ 26.3168 s (if WDT_CLK = 10 kHz).
- Reset period = $(1 / 10 \text{ kHz}) * 63$, if WDT_CLK = 10 kHz.



6.10 UART Interface Controller (UART)

NuMicro M051™ series provides two channels of Universal Asynchronous Receiver/Transmitters (UART). UART0~1 performs Normal Speed UART, and support flow control function.

6.10.1 Overview

The Universal Asynchronous Receiver/Transmitter (UART) performs a serial-to-parallel conversion on data received from the peripheral, and a parallel-to-serial conversion on data transmitted from the CPU. The UART controller also supports IrDA SIR Function, LIN master/slave mode function and RS-485 mode functions. Each UART channel supports seven types of interrupts including transmitter FIFO empty interrupt (INT_THRE), receiver threshold level reaching interrupt (INT_RDA), line status interrupt (parity error or framing error or break interrupt) (INT_RLS), receiver buffer time out interrupt (INT_TOUT), MODEM/Wakeup status interrupt (INT_MODEM), Buffer error interrupt (INT_BUF_ERR) and LIN receiver break field detected interrupt (INT_LIN_RX_BREAK).

The UART0 and UART1 are built-in with a 16-byte transmitter FIFO (TX_FIFO) and a 16-byte receiver FIFO (RX_FIFO) that reduces the number of interrupts presented to the CPU. The CPU can read the status of the UART at any time during the operation. The reported status information includes the type and condition of the transfer operations being performed by the UART, as well as 3 error conditions (parity error, framing error, break interrupt) probably occur while receiving data. The UART includes a programmable baud rate generator that is capable of dividing clock input by divisors to produce the serial clock that transmitter and receiver need. The baud rate equation is $\text{Baud Rate} = \text{UART_CLK} / M * [\text{BRD} + 2]$, where M and BRD are defined in Baud Rate Divider Register (UA_BAUD). Table 6-3 lists the equations in the various conditions and Table 6-4 list the UART baud rate setting table.

Mode	DIV_X_EN	DIV_X_ONE	Divider X	BRD	M	Baud rate equation
0	0	0	B	A	16	$\text{UART_CLK} / [16 * (A+2)]$
1	1	0	B	A	B+1	$\text{UART_CLK} / [(B+1) * (A+2)]$, B must ≥ 8
2	1	1	Don't care	A	1	$\text{UART_CLK} / (A+2)$, A must ≥ 3

Table 6-3 UART Baud Rate Equation



System clock = 22.1184MHz			
Baud rate	Mode0	Mode1	Mode2
921600	Not support	A=0,B=11	A=22
460800	A=1	A=1,B=15 A=2,B=11	A=46
230400	A=4	A=4,B=15 A=6,B=11	A=94
115200	A=10	A=10,B=15 A=14,B=11	A=190
57600	A=22	A=22,B=15 A=30,B=11	A=382
38400	A=34	A=62,B=8 A=46,B=11 A=34,B=15	A=574
19200	A=70	A=126,B=8 A=94,B=11 A=70,B=15	A=1150
9600	A=142	A=254,B=8 A=190,B=11 A=142,B=15	A=2302
4800	A=286	A=510,B=8 A=382,B=11 A=286,B=15	A=4606

Table 6-4 UART Baud Rate Setting Table

The UART0 and UART1 controllers support auto-flow control function that uses two low-level signals, /CTS (clear-to-send) and /RTS (request-to-send), to control the flow of data transfer between the UART and external devices (ex: Modem). When auto-flow is enabled, the UART is not allowed to receive data until the UART asserts /RTS to external device. When the number of bytes in the RX FIFO equals the value of RTS_TRI_LEV (UA_FCR [19:16]), the /RTS is de-asserted. The UART sends data out when UART controller detects /CTS is asserted from external device. If the valid asserted /CTS is not detected, the UART controller will not send data out.

The UART controllers also provides Serial IrDA (SIR, Serial Infrared) function (User must set UA_FUN_SEL [1:0] = '10' to enable IrDA function). The SIR specification defines a short-range infrared asynchronous serial transmission mode with one start bit, 8 data bits, and 1 stop bit. The maximum data rate is 115.2 Kbps (half duplex). The IrDA SIR block contains an IrDA SIR Protocol encoder/decoder. The IrDA SIR protocol is half-duplex only. So it cannot transmit and receive data at the same time. The IrDA SIR physical layer specifies a minimum 10ms transfer delay between transmission and reception. This delay feature must be implemented by software.

The alternate function of UART controllers is LIN (Local Interconnect Network) function. The LIN mode is selected by setting UA_FUN_SEL [1:0] = '01'. In LIN mode, one start bit and 8-bit data format with 1-bit stop bit are required in accordance with the LIN standard.



Another alternate function of UART controllers is RS-485 9 bit mode function, and direction control provided by RTS pin or can program GPIO (P0.3 for RTS0 and P0.1 for RTS1) to implement the function by software. The RS-485 mode is selected by setting the UA_FUN_SEL register to select RS-485 function. The RS-485 driver control is implemented by using the RTS control signal from an asynchronous serial port to enable the RS-485 driver. In RS-485 mode, many characteristics of the RX and TX are same as UART.

6.10.2 Features

- Full duplex, asynchronous communications
- Separate receive / transmit 16/16 bytes entry FIFO for data payloads
- Support hardware auto flow control/flow control function (CTS, RTS) and programmable RTS flow control trigger level
- Programmable receiver buffer trigger level
- Support programmable baud-rate generator for each channel individually
- Support CTS wake up function
- Support 8 bit receiver buffer time out detection function
- Programmable transmitting data delay time between the last stop and the next start bit by setting UA_TOR [DLY] register
- Support break error, frame error, parity error and receive / transmit buffer overflow detect function
- Fully programmable serial-interface characteristics
 - Programmable number of data bit, 5, 6, 7, 8 bit character
 - Programmable parity bit, even, odd, no parity or stick parity bit generation and detection
 - Programmable stop bit, 1, 1.5, or 2 stop bit generation
- Support IrDA SIR function mode
 - Support for 3/16 bit duration for normal mode
- Support LIN function mode
 - Support LIN master/slave mode
 - Support programmable break generation function for transmitter
 - Support break detect function for receiver
- Support RS-485 function mode.
 - Support RS-485 9bit mode
 - Support hardware or software enable to program RTS pin to control RS-485 transmission direction directly

6.11 Analog-to-Digital Converter (ADC)

6.11.1 Overview

NuMicro M051™ series contain one 12-bit successive approximation analog-to-digital converters (SAR A/D converter) with 8 input channels. The A/D converter supports four operation modes: single, burst, single-cycle scan and continuous scan mode. The A/D converters can be started by software and external STADC/P3.2 pin.

6.11.2 Features

- Analog input voltage range: 0~AV_{DD} (Max to 5.0V).
- 12-bit resolution and 10-bit accuracy is guaranteed.
- Up to 8 single-end analog input channels or 4 differential analog input channels.
- Maximum ADC clock frequency is 16 MHz.
- Up to 760k SPS conversion rate.
- Four operating modes
 - Single mode: A/D conversion is performed one time on a specified channel.
 - Single-cycle scan mode: A/D conversion is performed one cycle on all specified channels with the sequence from the lowest numbered channel to the highest numbered channel.
 - Continuous scan mode: A/D converter continuously performs Single-cycle scan mode until software stops A/D conversion.
 - Burst mode: A/D conversion will sample and convert the specified single channel and sequentially store in FIFO.
- An A/D conversion can be started by
 - Software Write 1 to ADST bit
 - External pin STADC
- Conversion results are held in data registers for each channel with valid and overrun indicators.
- Conversion result can be compared with specify value and user can select whether to generate an interrupt when conversion result matches the compare register setting.
- Channel 7 supports 3 input sources: external analog voltage, internal bandgap voltage, and internal temperature sensor output.

6.12 External Bus Interface (EBI)

6.12.1 Overview

NuMicro M051™ series equips an external bus interface (EBI) for external device used.

To save the connections between external device and this chip, EBI support address bus and data bus multiplex mode. And, address latch enable (ALE) signal supported differentiate the address and data cycle.

6.12.2 Features

External Bus Interface has the following functions:

1. External devices with max. 64K-byte size (8 bit data width)/128K-byte (16 bit data width) supported
2. Variable external bus base clock (MCLK) supported
3. 8 bit or 16 bit data width supported
4. Variable data access time (tACC), address latch enable time (tALE) and address hold time (tAHD) supported
5. Address bus and data bus multiplex mode supported to save the address pins
6. Configurable idle cycle supported for different access condition: Write command finish (W2X), Read-to-Read (R2R)

6.13 Flash Memory Controller (FMC)

6.13.1 Overview

NuMicro M051™ series equips with 16K/8K bytes on chip embedded Flash EEPROM for application program memory (APROM) that can be updated through ISP/IAP procedure. In System Programming (ISP) function enables user to update program memory when chip is soldered on PCB. After chip power on Cortex-M0 CPU fetches code from APROM or LDROM decided by boot select (CBS) in Config0. By the way, NuMicro M051™ series also provide additional 4K bytes DATA Flash for user to store some application depended data before chip power off in 16/8K bytes APROM model.

6.13.2 Features

- Run up to 50 MHz with zero wait state for continuous address read access
- 16/8KB application program memory (APROM)
- 4KB in system programming (ISP) loader program memory (LDROM)
- Fixed 4KB data flash with 512 bytes page erase unit
- In System Program (ISP)/In Application Program (IAP) to update on chip Flash EPROM



7 TYPICAL APPLICATION CIRCUIT

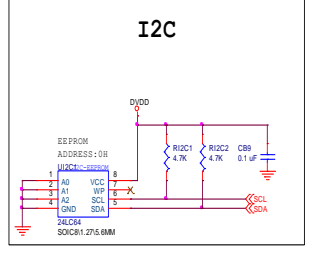
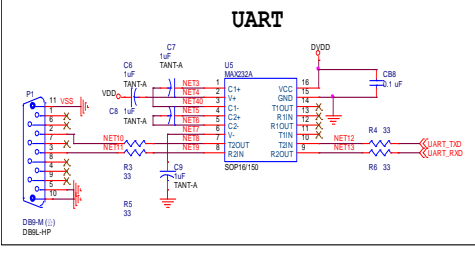
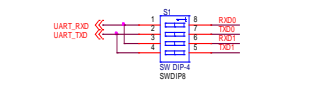
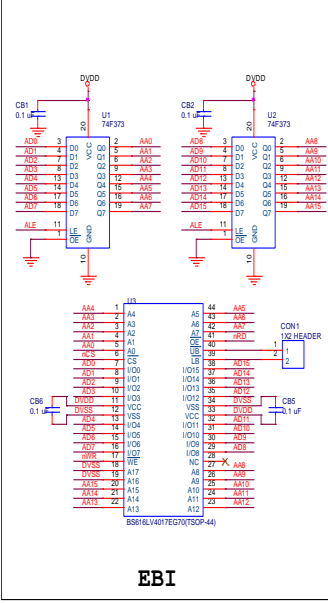
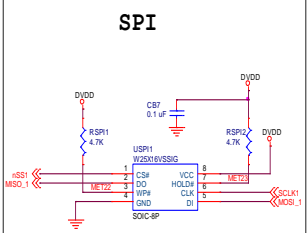
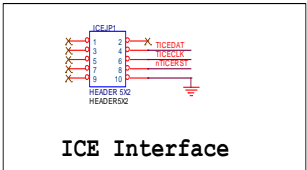
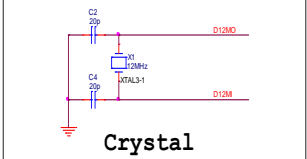
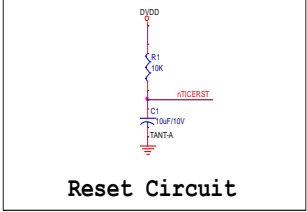
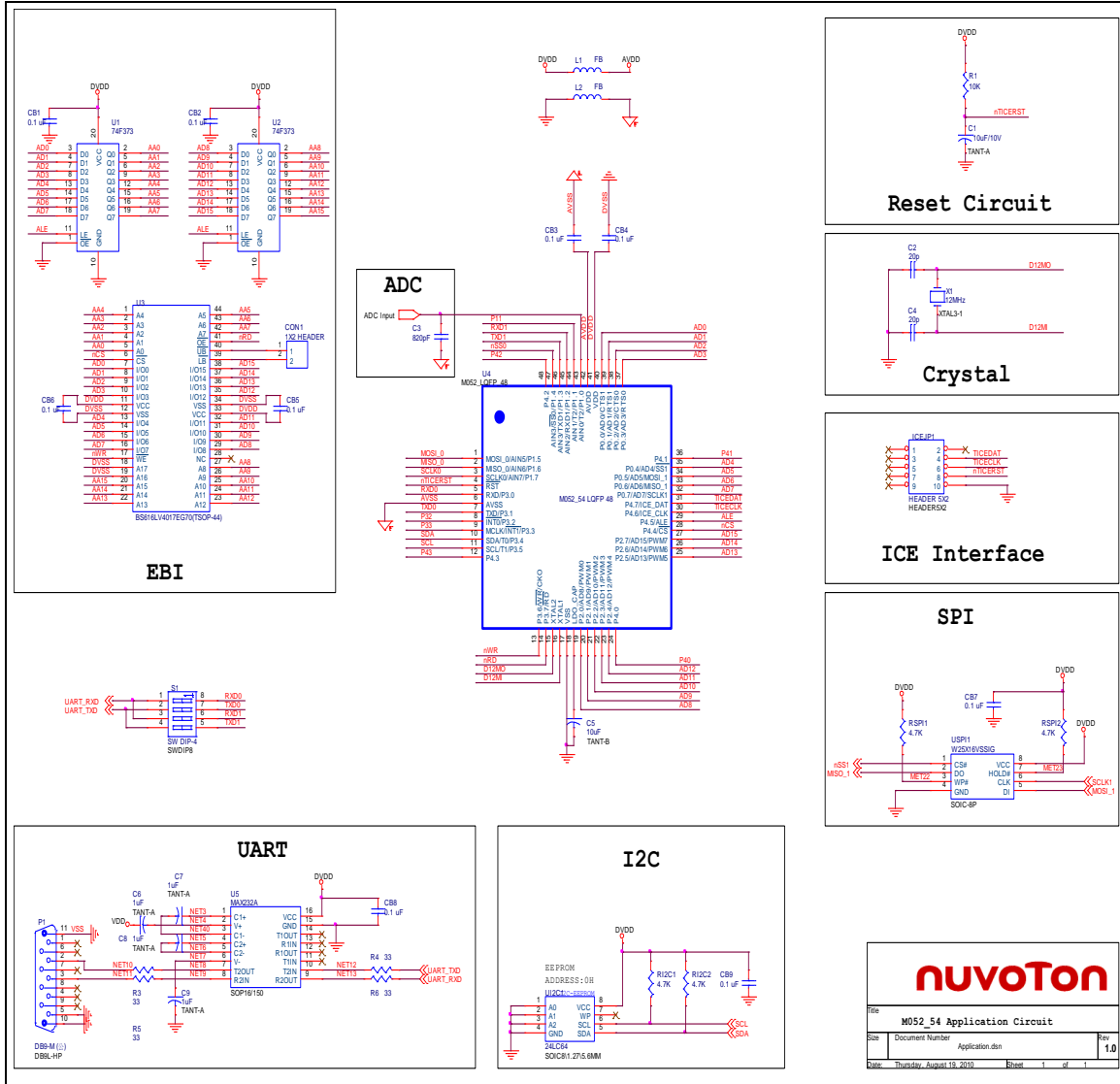

Title		M052_54 Application Circuit	
Size	Document Number	Application.dsn	Rev 1.0
Date		Thursday, August 19, 2010	Sheet 1 of 1



8 ELECTRICAL CHARACTERISTICS

8.1 Absolute Maximum Ratings

SYMBOL	PARAMETER	MIN	MAX	UNIT
DC Power Supply	$V_{DD} - V_{SS}$	-0.3	+7.0	V
Input Voltage	V_{IN}	$V_{SS} - 0.3$	$V_{DD} + 0.3$	V
Oscillator Frequency	$1/t_{CLCL}$	4	24	MHz
Operating Temperature	T_A	-40	+85	°C
Storage Temperature	T_{ST}	-55	+150	°C
Maximum Current into V_{DD}		-	120	mA
Maximum Current out of V_{SS}			120	mA
Maximum Current sunk by a I/O pin			35	mA
Maximum Current sourced by a I/O pin			35	mA
Maximum Current sunk by total I/O pins			100	mA
Maximum Current sourced by total I/O pins			100	mA

Note: Exposure to conditions beyond those listed under absolute maximum ratings may adversely affects the life and reliability of the device.



8.2 DC Electrical Characteristics

($V_{DD} - V_{SS} = 2.5 \sim 5.5V$, $T_A = 25^\circ C$, $F_{OSC} = 50 \text{ MHz}$ unless otherwise specified.)

PARAMETER	SYM.	SPECIFICATION				TEST CONDITIONS
		MIN.	TYP.	MAX.	UNIT	
Operation voltage	V_{DD}	2.5		5.5	V	$V_{DD} = 2.5V \sim 5.5V$ up to 50 MHz
LDO Output Voltage	V_{LDO}	1.7	1.8	1.9	V	$V_{DD} \geq 2.5V$
Band Gap Analog Input	V_{BG}	-5%	1.20	+5%	V	$V_{DD} = 2.5V \sim 5.5V$
Analog Operating Voltage	AV_{DD}	0		V_{DD}	V	
Analog Reference Voltage	V_{ref}	0		AV_{DD}	V	
Operating Current Normal Run Mode @ 50 MHz	IDD1		20.6		mA	$V_{DD} = 5.5V @ 50MHz$, enable all IP and PLL, XTAL=12MHz
	IDD2		14.4		mA	$V_{DD} = 5.5V @ 50MHz$, disable all IP and enable PLL, XTAL=12MHz
	IDD3		18.9		mA	$V_{DD} = 3.3V @ 50MHz$, enable all IP and PLL, XTAL=12MHz
	IDD4		12.8		mA	$V_{DD} = 3.3V @ 50MHz$, disable all IP and enable PLL, XTAL=12MHz
Operating Current Normal Run Mode @ 22Mhz	IDD5		6.2		mA	$V_{DD} = 5.5V @ 22MHz$, enable all IP and IRC22M, disable PLL
	IDD6		3.4		mA	$V_{DD} = 5.5V @ 22MHz$, disable all IP and enable IRC22M, disable PLL
	IDD7		6.1		mA	$V_{DD} = 3.3V @ 22MHz$, enable all IP and IRC22M, disable PLL
	IDD8		3.4		mA	$V_{DD} = 3.3V @ 22MHz$, disable all IP and enable IRC22M, disable PLL
Operating Current Normal Run Mode @ 12Mhz	IDD9		5.3		mA	$V_{DD} = 5.5V @ 12MHz$, enable all IP and disable PLL, XTAL=12MHz
	IDD10		3.7		mA	$V_{DD} = 5.5V @ 12MHz$, disable all IP and disable PLL, XTAL=12MHz
	IDD11		4.0		mA	$V_{DD} = 3.3V @ 12MHz$, enable all IP and disable PLL, XTAL=12MHz
	IDD12		2.3		mA	$V_{DD} = 3.3V @ 12MHz$, disable all IP and disable PLL, XTAL=12MHz



PARAMETER	SYM.	SPECIFICATION				TEST CONDITIONS
		MIN.	TYP.	MAX.	UNIT	
Operating Current Normal Run Mode @ 4 MHz	IDD13		3.4		mA	V _{DD} = 5.5V@4MHz, enable all IP and disable PLL, XTAL=4MHz
	IDD14		2.6		mA	V _{DD} = 5.5V@4MHz, disable all IP and disable PLL, XTAL=4MHz
	IDD15		2.0		mA	V _{DD} = 3.3V@4MHz, enable all IP and disable PLL, XTAL=4MHz
	IDD16		1.3		mA	V _{DD} = 3.3V@4MHz, disable all IP and disable PLL, XTAL=4MHz
Operating Current Normal Run Mode @ 10Khz	IDD17		98.7		uA	V _{DD} = 5.5V@10KHz, enable all IP and IRC10K, disable PLL
	IDD18		97.4		uA	V _{DD} = 5.5V@10KHz, disable all IP and enable IRC10K, disable PLL
	IDD19		86.4		uA	V _{DD} = 3.3V@10KHz, enable all IP and IRC10K, disable PLL
	IDD20		85.2		uA	V _{DD} = 3.3V@10KHz, disable all IP and enable IRC10K, disable PLL
Operating Current Idle Mode @ 50 MHz	IIDLE1		16.2		mA	V _{DD} = 5.5V@50 MHz, enable all IP and PLL, XTAL=12 MHz
	IIDLE2		10.0		mA	V _{DD} =5.5V@50 MHz, disable all IP and enable PLL, XTAL=12 MHz
	IIDLE3		14.6		mA	V _{DD} = 3V@50 MHz, enable all IP and PLL, XTAL=12 MHz
	IIDLE4		8.5		mA	V _{DD} = 3V@50 MHz, disable all IP and enable PLL, XTAL=12 MHz
Operating Current Idle Mode @ 22Mhz	IIDLE5		4.3		mA	V _{DD} = 5.5V@22MHz, enable all IP and IRC22M, disable PLL
	IIDLE6		1.5		mA	V _{DD} =5.5V@22MHz, disable all IP and enable IRC22M, disable PLL
	IIDLE7		4.2		mA	V _{DD} = 3.3V@22MHz, enable all IP and IRC22M, disable PLL
	IIDLE8		1.4		mA	V _{DD} = 3.3V@22MHz, disable all IP and enable IRC22M, disable PLL
Operating Current Idle Mode @ 12 MHz	IIDLE9		4.3		mA	V _{DD} = 5.5V@12MHz, enable all IP and disable PLL, XTAL=12MHz
	IIDLE10		2.6		mA	V _{DD} = 5.5V@12MHz, disable all IP and disable PLL, XTAL=12MHz



PARAMETER	SYM.	SPECIFICATION				TEST CONDITIONS
		MIN.	TYP.	MAX.	UNIT	
	IIDLE11		2.9		mA	V _{DD} = 3.3V@12MHz, enable all IP and disable PLL, XTAL=12MHz
	IIDLE12		1.3		mA	V _{DD} = 3.3V@12MHz, disable all IP and disable PLL, XTAL=12MHz
Operating Current Idle Mode @ 4 MHz	IIDLE13		3.0		mA	V _{DD} = 5.5V@4MHz, enable all IP and disable PLL, XTAL=4MHz
	IIDLE14		2.3		mA	V _{DD} = 5.5V@4MHz, disable all IP and disable PLL, XTAL=4MHz
	IIDLE15		1.7		mA	V _{DD} = 3.3V@4MHz, enable all IP and disable PLL, XTAL=4MHz
	IIDLE16		1.0		mA	V _{DD} = 3.3V@4MHz, disable all IP and disable PLL, XTAL=4MHz
Operating Current Idle Mode @ 10Khz	IIDLE17		97.8		uA	V _{DD} = 5.5V@10KHz, enable all IP and IRC10K, disable PLL
	IIDLE18		96.5		uA	V _{DD} = 5.5V@10KHz, disable all IP and enable IRC10K, disable PLL
	IIDLE19		85.5		uA	V _{DD} = 3.3V@10KHz, enable all IP and IRC10K, disable PLL
	IIDLE20		84.4		uA	V _{DD} = 3.3V@10KHz, disable all IP and enable IRC10K, disable PLL
Standby Current Power-down Mode (Deep Sleep Mode)	IPWD1		10		μA	V _{DD} = 5.5V, No load @ Disable BOV function
	IPWD2		10		μA	V _{DD} = 3.0V, No load @ Disable BOV function
Input Current P0/1/2/3/4 (Quasi-bidirectional mode)	IIN1	-75	-	+15	μA	V _{DD} = 5.5V, VIN = 0V or VIN= V _{DD}
Input Leakage Current P0/1/2/3/4	ILK	-1	-	+1	μA	V _{DD} = 5.5V, 0<VIN< V _{DD}
Input Low Voltage P0/1/2/3/4 (TTL input)	VIL1	-0.3	-	0.8	V	V _{DD} = 4.5V
		-0.3	-	0.6		V _{DD} = 2.5V
Input High Voltage P0/1/2/3/4 (TTL input)	VIH1	2.0	-	V _{DD} +0.2	V	V _{DD} = 5.5V
		1.5	-	V _{DD} +0.2		V _{DD} =3.0V
Input Low Voltage XT1[*2]	VIL3	0	-	0.8	V	V _{DD} = 4.5V
		0	-	0.4		V _{DD} = 2.5V
Input High Voltage XT1[*2]	VIH3	3.5	-	V _{DD} +0.2	V	V _{DD} = 5.5V



PARAMETER	SYM.	SPECIFICATION				TEST CONDITIONS
		MIN.	TYP.	MAX.	UNIT	
		2.4	-	$V_{DD} + 0.2$		$V_{DD} = 3.0V$
Negative going threshold (Schmitt input), /RST	VILS	-0.5	-	$0.2 V_{DD}$	V	
Positive going threshold (Schmitt input), /RST	VIHS	$0.7 V_{DD}$	-	$V_{DD} + 0.5$	V	
Internal /RST pin pull up resistor	RRST	40		150	K Ω	
Negative going threshold (Schmitt input), P0/1/2/3/4	VILS	-0.5	-	$0.3 V_{DD}$	V	
Positive going threshold (Schmitt input), P0/1/2/3/4	VIHS	$0.7 V_{DD}$	-	$V_{DD} + 0.5$	V	
Source Current P0/1/2/3/4 (Quasi-bidirectional Mode)	ISR11	-300	-370	-450	μA	$V_{DD} = 4.5V, V_S = 2.4V$
	ISR12	-50	-70	-90	μA	$V_{DD} = 2.7V, V_S = 2.2V$
	ISR13	-40	-60	-80	μA	$V_{DD} = 2.5V, V_S = 2.0V$
Source Current P0/1/2/3/4 (Push-pull Mode)	ISR21	-20	-24	-28	mA	$V_{DD} = 4.5V, V_S = 2.4V$
	ISR22	-4	-6	-8	mA	$V_{DD} = 2.7V, V_S = 2.2V$
	ISR23	-3	-5	-7	mA	$V_{DD} = 2.5V, V_S = 2.0V$
Sink Current P0/1/2/3/4 (Quasi-bidirectional and Push-pull Mode)	ISK11	10	16	20	mA	$V_{DD} = 4.5V, V_S = 0.45V$
	ISK12	7	10	13	mA	$V_{DD} = 2.7V, V_S = 0.45V$
	ISK13	6	9	12	mA	$V_{DD} = 2.5V, V_S = 0.45V$
Brown-Out voltage with BOV_VL [1:0] =00b	VBO2.2	2.0	2.2	2.4	V	$V_{DD} = 5.5V$
Brown-Out voltage with BOV_VL [1:0] =01b	VBO2.7	2.5	2.7	2.9	V	$V_{DD} = 5.5V$
Brown-Out voltage with BOV_VL [1:0] =10b	VBO3.8	3.5	3.7	3.9	V	$V_{DD} = 5.5V$
Brown-Out voltage with BOV_VL [1:0] =11b	VBO4.5	4.1	4.3	4.5	V	$V_{DD} = 5.5V$
Hysteresis range of BOD voltage	VBH	30	-	150	mV	$V_{DD} = 2.5V-5.5V$

Notes:

1. /RST pin is a Schmitt trigger input.
2. XTAL1 is a CMOS input.
3. Pins of P0, P1, P2, P3 and P4 can source a transition current when they are being externally driven from 1 to 0. In the condition of $V_{DD}=5.5V$, the transition current reaches its maximum value when V_{in} approximates to 2V .



8.3 AC Electrical Characteristics

8.3.1 External Crystal

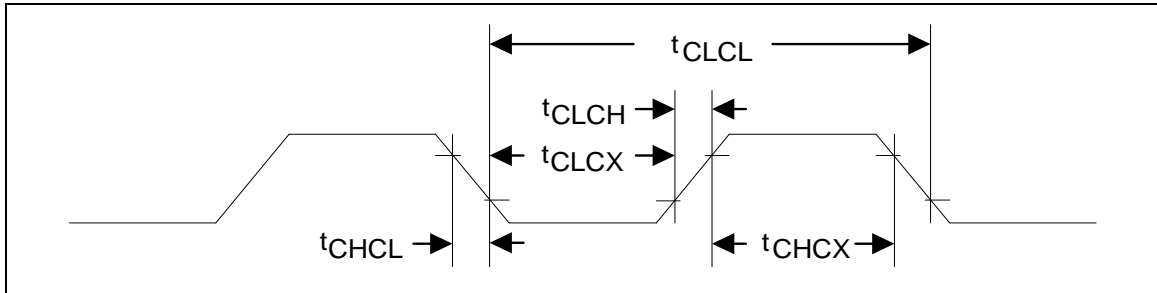

Note: Duty cycle is 50%.

PARAMETER	SYMBOL	MIN.	TYP.	MAX.	UNITS	CONDITION
Clock High Time	t_{CHCX}	20	-	-	nS	
Clock Low Time	t_{CLCX}	20	-	-	nS	
Clock Rise Time	t_{CLCH}	-	-	10	nS	
Clock Fall Time	t_{CHCL}	-	-	10	nS	

8.3.2 External Oscillator

PARAMETER	CONDITION	MIN.	TYP.	MAX.	UNIT
Input clock frequency	External crystal	4	12	24	MHz
Temperature	-	-40	-	85	°C
V_{DD}	-	2.5	5	5.5	V
Operating current	12 MHz@ $V_{DD} = 5V$	-	1	-	mA

8.3.3 Typical Crystal Application Circuits

CRYSTAL	C1	C2
4 MHz ~ 24 MHz	Optional (Depend on crystal specification)	

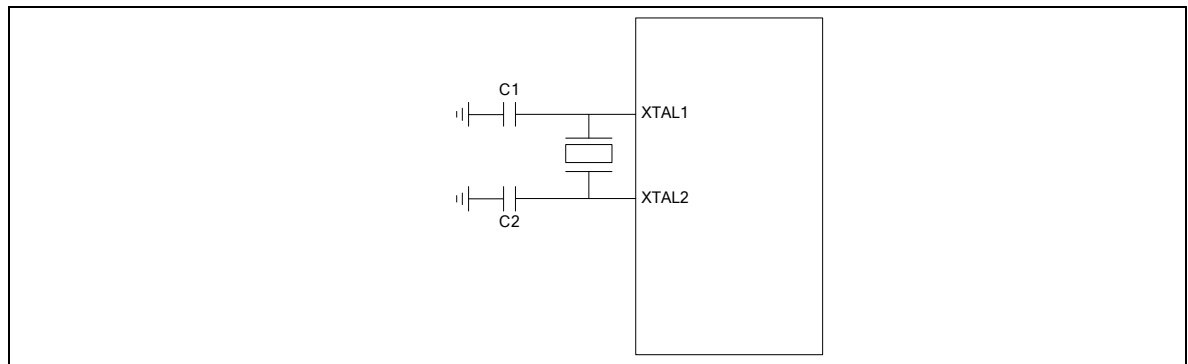

Figure 8-1 Typical Crystal Application Circuit



8.3.4 Internal 22.1184 MHz RC Oscillator

PARAMETER	CONDITION	MIN.	TYP.	MAX.	UNIT
Center Frequency	-	-	22.1184		MHz
Calibrated Internal Oscillator Frequency	+25 °C; V _{DD} =5V	-3	-	+3	%
	-40 °C~+85 °C; V _{DD} =2.5V~5.5V	-5	-	+5	%
Operating current	V _{DD} =5V	-	500	-	uA

8.3.5 Internal 10kHz RC Oscillator

PARAMETER	CONDITION	MIN.	TYP.	MAX.	UNIT
Supply voltage ^[1]	-	2.5	-	5.5	V
Center Frequency	-	-	10	-	kHz
Calibrated Internal Oscillator Frequency	+25 °C; V _{DD} =5V	-30	-	+30	%
	-40 °C~+85 °C; V _{DD} =2.5V~5.5V	-50	-	+50	%
Operating current	V _{DD} =5V	-	5	-	uA

Notes:

1. Internal operation voltage comes from LDO.



8.4 Analog Characteristics

8.4.1 Specification of 12-bit SARADC

PARAMETER	SYM.	MIN.	TYP.	MAX.	UNIT
Resolution	-	-	-	12	Bit
Differential nonlinearity error	DNL	-	±1.2	-	LSB
Integral nonlinearity error	INL	-	±1.2	-	LSB
Offset error	EO	-	+3	+5	LSB
Gain error (Transfer gain)	EG	-	-4	-6	-
Monotonic	-	Guaranteed			-
ADC clock frequency	FADC	-	-	16	MHz
Conversion time	TADC	-	13	-	Clock
Sample rate	FS	-	-	760	K SPS
Supply voltage	V _{LDO}	-	1.8	-	V
	V _{ADD}	3	-	5.5	V
Supply current (Avg.)	I _{DD}	-	0.5	-	mA
	I _{DDA}	-	1.5	-	mA
Input voltage range	V _{IN}	0	-	V _{DD}	V
Capacitance	C _{IN}	-	5	-	pF



8.4.2 Specification of LDO & Power management

PARAMETER	MIN	TYP	MAX	UNIT	NOTE
Input Voltage	2.5	5	5.5	V	V _{DD} input voltage
Output Voltage	-10%	1.8	+10%	V	LDO output voltage
Temperature	-40	25	85	°C	
C	-	1u	-	F	Resr=1ohm

Note:

1. It is recommended a 100nF bypass capacitor is connected between V_{DD} and the closest V_{SS} pin of the device.
2. For ensuring power stability, a 1uF or higher capacitor must be connected between LDO pin and the closest V_{SS} pin of the device.



8.4.3 Specification of Low Voltage Reset

PARAMETER	CONDITION	MIN.	TYP.	MAX.	UNIT
Operation voltage	-	2.5	5	5.5	V
Temperature	-	-40	25	85	°C
Quiescent current	V _{DD} =5.5V	-	-	5	uA
Threshold voltage	Temperature=25°	1.7	2.0	2.3	V
	Temperature=-40°	-	2.3	-	V
	Temperature=85°	-	1.8	-	V
Hysteresis	-	0	0	0	V

8.4.4 Specification of Brown-Out Detector

Parameter	Condition	Min.	Typ.	Max.	Unit
Operation voltage	-	2.5	-	5.5	V
Quiescent current	AV _{DD} =5.5V	-	-	140	μA
Temperature	-	-40	25	85	°C
Brown-Out voltage	BOV_VL[1:0]=11	4.1	4.3	4.5	V
	BOV_VL [1:0]=10	3.5	3.7	3.9	V
	BOV_VL [1:0]=01	2.5	2.7	2.9	V
	BOV_VL [1:0]=00	2.0	2.2	2.4	V
Hysteresis	-	30m	-	150m	V

8.4.5 Specification of Power-On Reset (5V)

Parameter	Condition	Min.	Typ.	Max.	Unit
Temperature	-	-40	25	85	°C
Reset voltage	V+	-	2	-	V
Quiescent current	V _{in} >reset voltage	-	1	-	nA



8.4.6 Specification of Temperature Sensor

PARAMETER	CONDITIONS	MIN.	TYP.	MAX.	UNIT
Supply voltage ^[1]		1.62	1.8	1.98	V
Temperature		-40	-	85	°C
Gain		-1.72	-1.76	-1.80	mV/°C
Offset	Temp=0 °C	717	725	733	mV

Note[1]: Internal operation voltage comes from LDO.

8.4.7 Specification of Comparator

PARAMETER	CONDITION	MIN.	TYP.	MAX.	UNIT
Temperature	-	-40	25	85	°C
V _{DD}	-	2.4	3	5.5	V
V _{DD} current	-	-	40	80	uA
Input offset voltage	-		10	20	mV
Output swing	-	0.1	-	V _{DD} -0.1	V
Input common mode range	-	0.1	-	V _{DD} -0.1	V
DC gain	-	-	70	-	dB
Propagation delay	@VCM=1.2 V and VDIFF=0.1 V	-	200	-	ns
Hysteresis	@VCM=0.2 V ~ V _{DD} -0.2V	-	±10	-	mV
Stable time	@CINP=1.3 V CINN=1.2 V	-	-	2	us

8.5 Flash DC Electrical Characteristics

SYMBOL	PARAMETER	CONDITIONS	MIN.	TYP.	MAX.	UNIT
N _{endu}	Endurance		100000			cycles ^[1]
T _{ret}	Retention time	Temp=85 °C	10			year
T _{erase}	Page erase time		19	20	21	ms
T _{mess}	Mess erase time		30	40	50	ms
T _{prog}	Program time		38	40	42	us
V _{DD}	Supply voltage		1.62	1.8	1.98	V ^[2]
I _{dd1}	Read current				0.25	mA
I _{dd2}	Program/Erase current				7	mA
I _{pd}	Power down current			1	20	uA

1. Number of program/erase cycles.
2. V_{DD} is source from chip LDO output voltage.
3. Guaranteed by design, not test in production.



9 PACKAGE DIMENSIONS

9.1 LQFP-48 (7x7x1.4mm² Footprint 2.0mm)

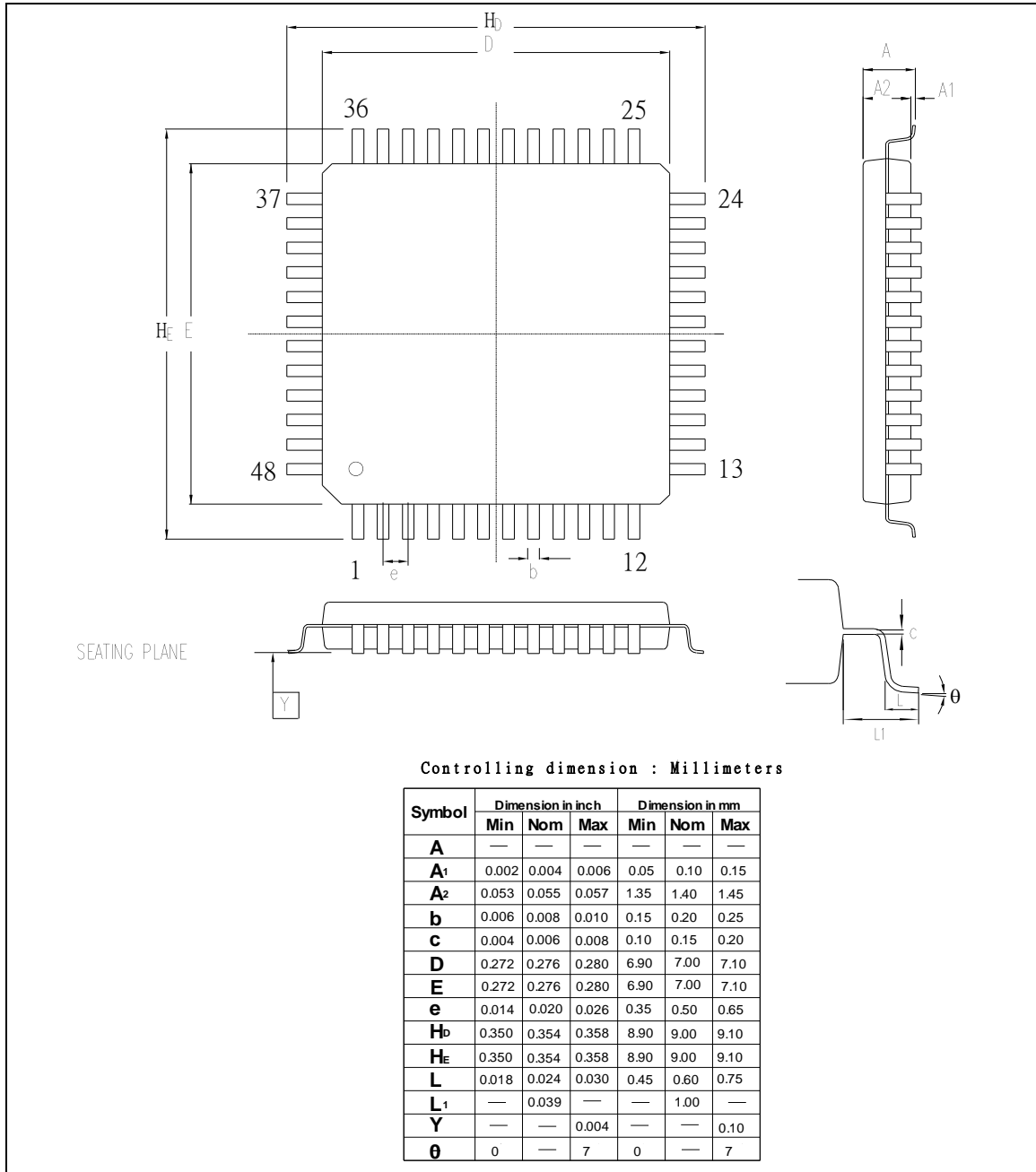

9.2 QFN-33 (5X5 mm², Thickness 0.8mm, Pitch 0.5 mm)

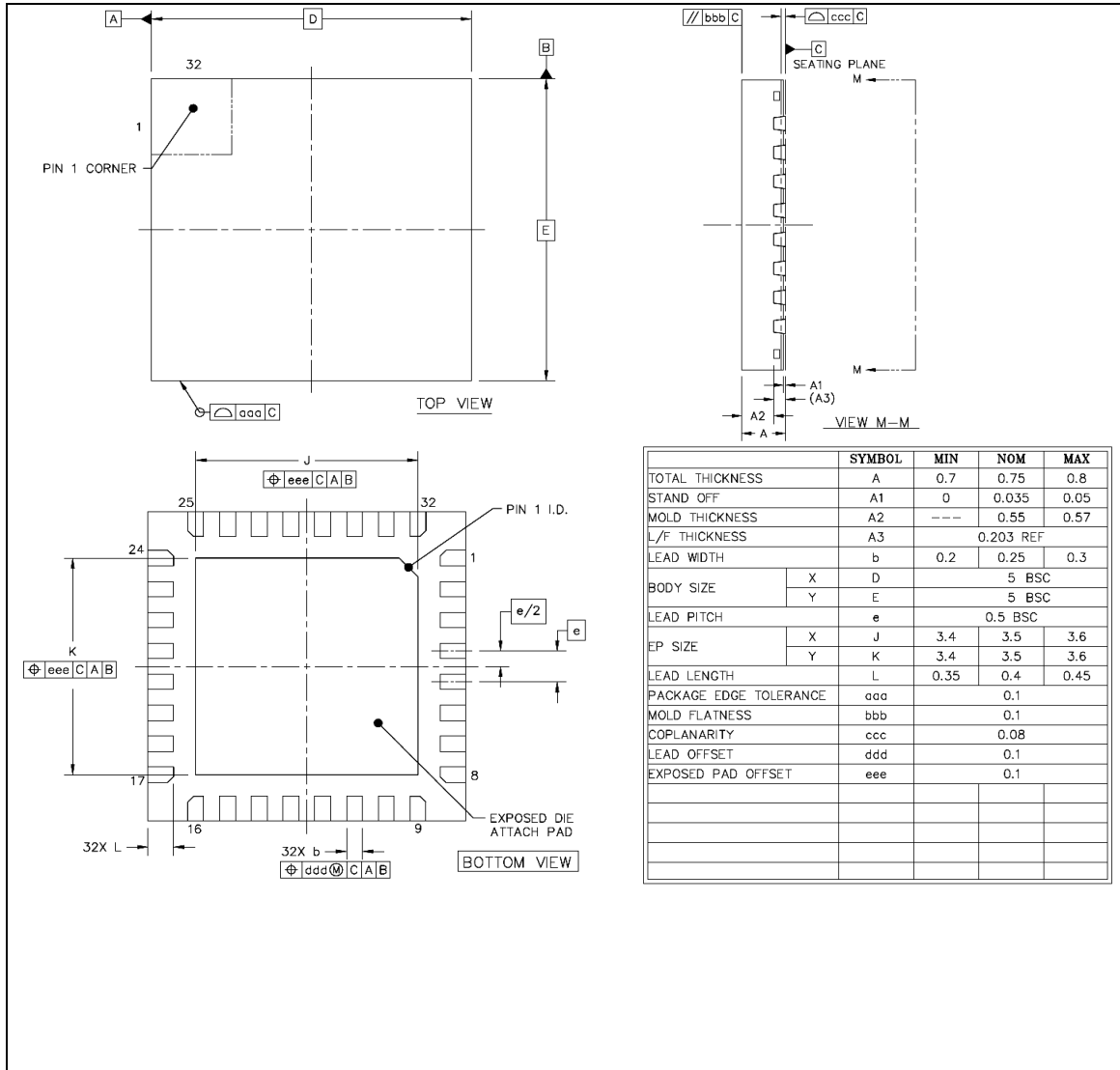



10 REVISION HISTORY

VERSION	DATE	PAGE	DESCRIPTION
V1.00	Oct 20, 2011	-	Initial issued
V1.01	Mar. 19, 2012	8.3.4	Updated the Center Frequency of 22Mhz RC spec



Important Notice

Nuvoton Products are neither intended nor warranted for usage in systems or equipment, any malfunction or failure of which may cause loss of human life, bodily injury or severe property damage. Such applications are deemed, "Insecure Usage".

Insecure usage includes, but is not limited to: equipment for surgical implementation, atomic energy control instruments, airplane or spaceship instruments, the control or operation of dynamic, brake or safety systems designed for vehicular use, traffic signal instruments, all types of safety devices, and other applications intended to support or sustain life.

All Insecure Usage shall be made at customer's risk, and in the event that third parties lay claims to Nuvoton as a result of customer's Insecure Usage, customer shall indemnify the damages and liabilities thus incurred by Nuvoton.

*Please note that all data and specifications are subject to change without notice.
All the trademarks of products and companies mentioned in this datasheet belong to their respective owners.*