

Document Name	M080AWP4 R0 Module Product Specification			Page 1 of 27	
Document No.		Made/Revised Date	2015/08/11	Ver.	04

IVO Product Specification

To:

Product Name: M080AWP4 R0

Document Issue Date: 2015/08/11

Customer	InfoVision Optoelectronics
<p><u>SIGNATURE</u></p> <p>_____</p> <p>_____</p> <p>_____</p> <p>Please return 1 copy for your confirmation with your signature and comments.</p>	<p><u>SIGNATURE</u></p> <p>REVIEWED BY CQM</p> <p>_____</p> <p>PREPARED BY FAE</p> <p>_____</p>

Note: 1. Please contact InfoVision Company before designing your product based on this product.
 2. The information contained herein is presented merely to indicate the characteristics and performance of our products. No responsibility is assumed by IVO for any intellectual property claims or other problems that may result from application based on the module described herein.

FQ-7-30-0-009-03

Document Name	M080AWP4 R0 Module Product Specification			Page 2 of 27	
Document No.		Made/Revised Date	2015/08/11	Ver.	04

Revised Record				
Ver.	Date	Revised Content/Summary	Page	Revised By
00	2013/12/10	New	All	/
01	2014/01/02	Update Mechanical Characteristics	24	/
02	2014/02/25	Update Gamma Reference Voltage	16	/
03	2014/04/04	Update CR & Color Chromaticity spec	1, 7	/
		Update Power Supply Voltage	15	
		Update Dimension Specifications	25	
04	2014/05/12	Update Power Consumption	3,19	/
		Update weight info	3,24	
		Update Outline Drawing	23	
		Update Reliability Conditions	26	

Document Name	M080AWP4 R0 Module Product Specification			Page 3 of 27	
Document No.		Made/Revised Date	2015/08/11	Ver.	04

CONTENTS

1.0 General Descriptions	4
2.0 Absolute Maximum Ratings	5
3.0 Pixel Format Image	6
4.0 Optical Characteristics	7
5.0 Backlight Characteristics	10
6.0 Electrical Characteristics	11
7.0 Interface Timings	15
8.0 Power Consumption	17
9.0 Power ON/OFF Sequence	19
10.0 Mechanical Characteristics	20
11.0 Package Specification	23
12.0 Reliability Conditions	24
13.0 Lot Mark	25
14.0 General Precaution	26

Document Name	M080AWP4 R0 Module Product Specification			Page 4 of 27	
Document No.		Made/Revised Date	2015/08/11	Ver.	04

1.0 General Descriptions

1.1 Introduction

The M080AWP4 R0 is a color active matrix thin film transistor (TFT) liquid crystal display (LCD) that uses amorphous silicon TFT as a switching device. It is composed of a TFT LCD panel, a timing controller, voltage reference, common voltage, column driver, This TFT LCD has a 8-inch diagonally measured active display area with WVGA resolution (800 horizontal by 480 vertical pixels array).

1.2 Features

- 8" TFT-LCD Panel
- LED Backlight System
- Supported WVGA Resolution

1.3 Product Summary

Items	Specifications	Unit
Screen Diagonal	8	inch
Active Area (H x V)	176.64 x 99.36	mm
Number of Pixels (H x V)	800 x3(RGB) x 480	-
Pixel Pitch (H x V)	0.2208x0.2070	mm
Pixel Arrangement	R.G.B. Vertical Stripe	-
Display Mode	TN Normally White	-
White Luminance ☆	500 (Typ.) , 400 (Min)	cd /m ²
Contrast Ratio ☆	800 (Typ.) , 640 (Min)	-
Response Time ☆	18 (Typ.) 25°C 148 (Typ) -20°C 323 (Typ) -30°C	ms
Input Voltage	3.0(Min) 3.3(Typ) 3.6(Max)	V
Power Consumption	2.75(Max.)	W
Weight	220(Max)	g
Outline Dimension (H x V x D)	190.0(H)x120.0(V)x6.0(D)(Max)	mm
Electrical Interface (Logic)	TTL	-
Support Color	16.2M	-
Optimum Viewing Direction	6 o'clock	-
Surface Treatment	Anti-glare & hardness 3H	-

Document Name	M080AWP4 R0 Module Product Specification			Page 5 of 27	
Document No.		Made/Revised Date	2015/08/11	Ver.	04

1.4 Functional Block Diagram

Figure 1 shows the functional block diagram of the LCD module.

Figure 1 Block Diagram

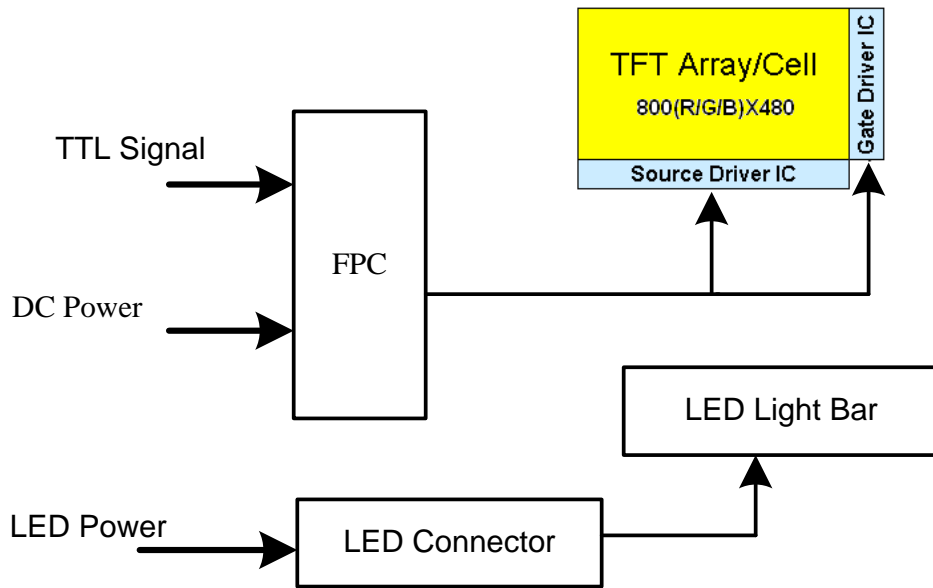

2.0 Absolute Maximum Ratings

Table 1 Absolute Ratings of Environment

Item	Symbol	Min.	Max.	Unit	Conditions
Supply Voltage	V _{DD}	-0.5	3.96	V	(1)
Operating Temperature	T _{OP}	-30	85	°C	(1) (2) (3) (4)
Operating Humidity	H _{OP}	10	90	%RH	-
Storage Temperature	T _{ST}	-40	95	°C	-
Storage Humidity	H _{ST}	10	90	%RH	-

Note (1): Humidity: 90%RH Max. (T<=40°C) Note static electricity.

Maximum wet bulb temperature at 39°C or less. (T>40°C) No condensation.

Note (2): There is a possibility of causing deterioration in the irregularity and others of the screen and the display fineness though the liquid crystal module doesn't arrive at destruction when using it at 80~85°C or -40~0°C.

Note (3): There is a possibility of causing the fineness deterioration by the prolonged use in the (high temperature) humidity environment (60% or more).

Note (4): In the operating temperature item, the low temperature side is the ambient temperature regulations. The high temperature side is the panel surface temperature regulations.

Document Name	M080AWP4 R0 Module Product Specification			Page 6 of 27	
Document No.		Made/Revised Date	2015/08/11	Ver.	04

Figure 2 Temperature & Humidity Range

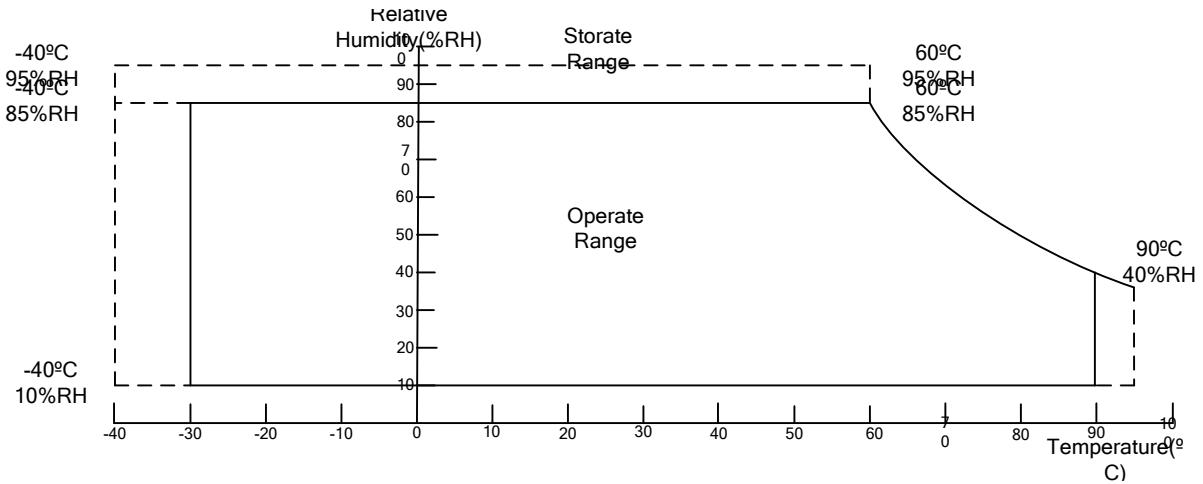

3.0 Pixel Format Image

Figure 3 shows the relationship of the input signals and LCD pixel format image.

Figure 3 Pixel Format

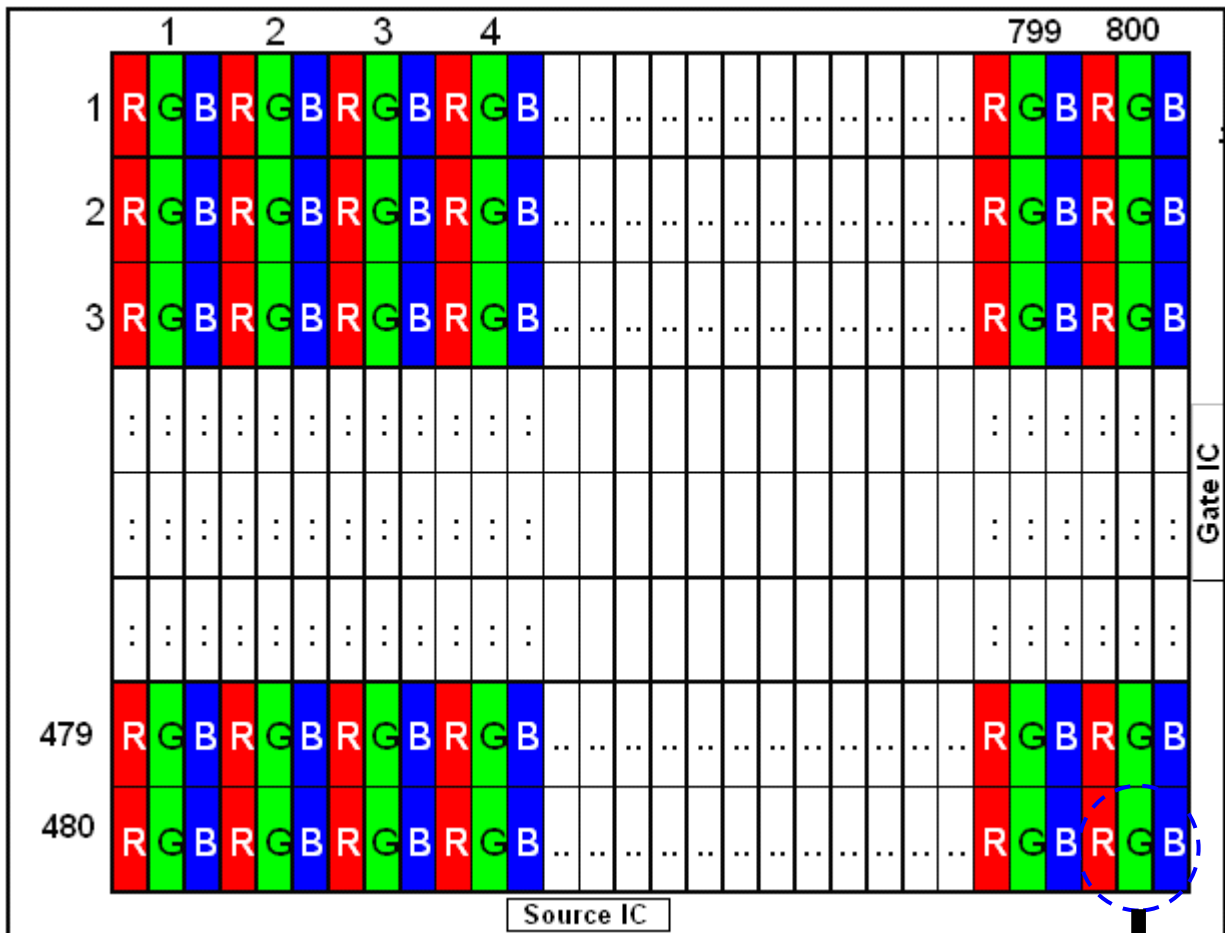

R Dot +G Dot +B Dot=1 Pixel

Document Name	M080AWP4 R0 Module Product Specification			Page 7 of 27	
Document No.		Made/Revised Date	2015/08/11	Ver.	04

4.0 Optical Characteristics

The optical characteristics are measured under stable conditions as following notes.

Table 2 Optical Characteristics

Item	Conditions		Min.	Typ.	Max.	Unit	Note
Viewing Angle (CR>10) ☆	Horizontal	θ_{x+}	65	75	-	degree	(1),(2),(3)
		θ_{x-}	65	75	-		
	Vertical	θ_{y+}	50	60	-		
		θ_{y-}	60	70	-		
Contrast Ratio☆	Center		640	800	-	-	(1),(2),(4)
Response Time ☆	Rising + Falling	25°C	-	18	30	ms	(1),(2),(5)
		-20°C	-	148	250		
		-30°C	-	323	550		
Color Chromaticity (CIE1931) ☆	White	x	0.260	0.310	0.360	-	(1),(2),(3) $\theta_x=\theta_y=0^\circ$
	White	y	0.280	0.330	0.380	-	
	Red	x	0.552	0.602	0.652	-	
	Red	y	0.302	0.352	0.402	-	
	Green	x	0.277	0.327	0.377	-	
	Green	y	0.522	0.572	0.622	-	
	Blue	x	0.111	0.161	0.211	-	
	Blue	y	0.063	0.113	0.163	-	
White Luminance ☆	Center Points		400	500	-	cd/m ²	(1),(2)
NTSC			45	48			(1),(2),(3)
Luminance Uniformity	9Points		70	-	-	%	(1),(2),(7)

Note (1) Measurement Setup:

The LCD module should be stabilized at given temperature(25°C) for 15 minutes to Avoid abrupt temperature change during measuring. In order to stabilize the luminance, the measurement should be executed after lighting backlight for 15 minutes in a windless room.

Document Name	M080AWP4 R0 Module Product Specification			Page 8 of 27	
Document No.		Made/Revised Date	2015/08/11	Ver.	04

Figure 4 Measurement Setup

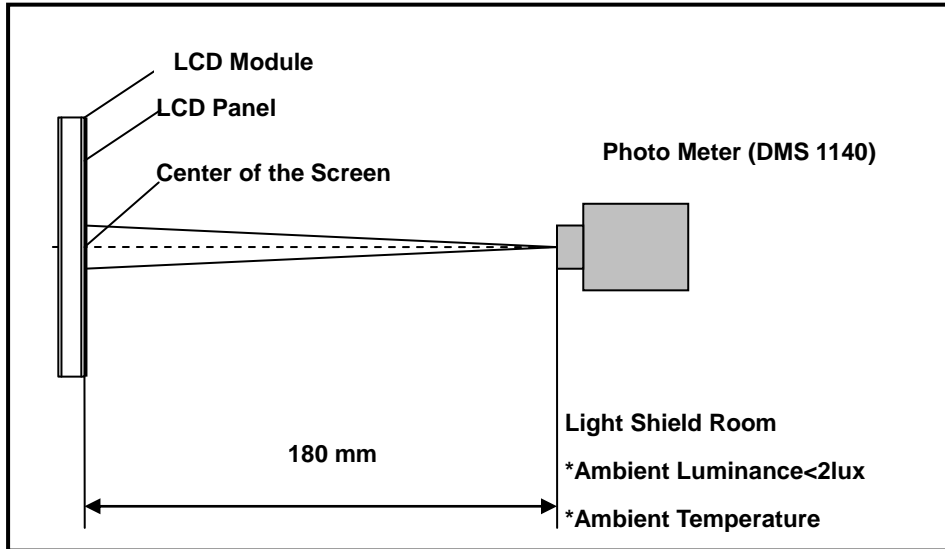

Note (2) The Backlight input parameter setting as:

V_BL: 25V

Note (3) Definition of Viewing Angle

Figure 5 Definition of Viewing Angle

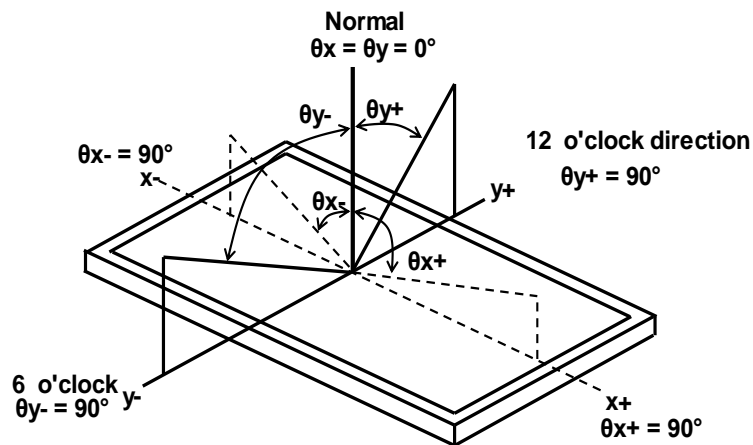

Note (4) Definition Of Contrast Ratio (CR)

The contrast ratio can be calculated by the following expression

$$\text{Contrast Ratio (CR)} = L_{63} / L_0$$

L63: Luminance of gray level 63, L0: Luminance of gray level 0

Note (5) Definition Of Response Time (TR, TF)

Document Name	M080AWP4 R0 Module Product Specification			Page 9 of 27	
Document No.		Made/Revised Date	2015/08/11	Ver.	04

Figure 6 Definition of Response Time

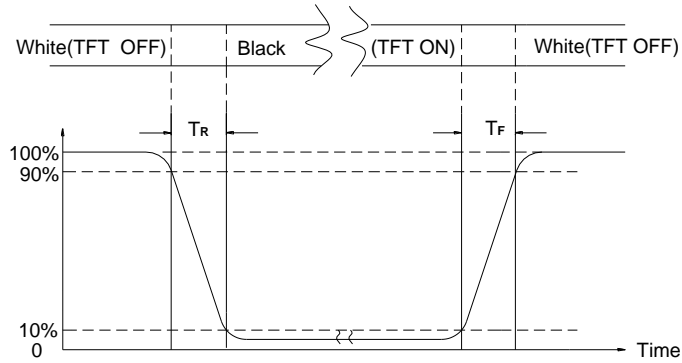

Note (6) Definition Of Luminance Uniformity (Ref.: Active Area)

Measure the luminance of gray level 63 at 9 points.

$$UNF(9pts) = \frac{\text{Min}(L1, L2, \dots, L9)}{\text{Max}(L1, L2, \dots, L9)}$$

Figure 7 Measurement Locations Of 9 Points

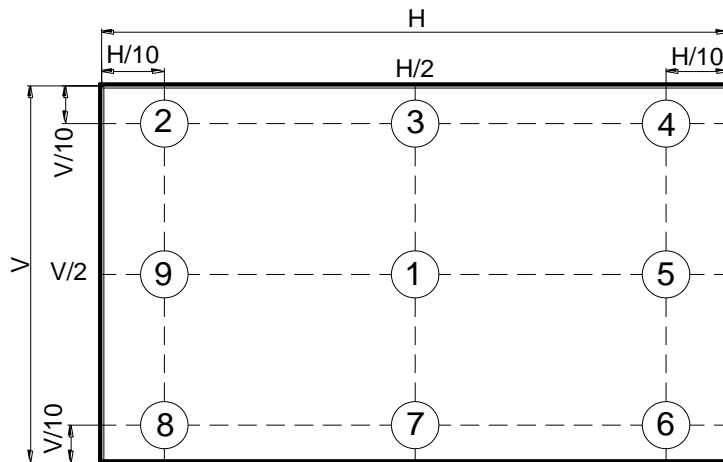

Document Name	M080AWP4 R0 Module Product Specification			Page 10 of 27	
Document No.		Made/Revised Date	2015/08/11	Ver.	04

5.0 Backlight Characteristics

5.1 Parameter Guideline Of LED Backlight

Table 3 Parameter Guideline for LED Backlight

Item	Symbol	Min.	Typ.	Max.	Units	Note
LED Input Voltage	V_{LED}	23.2	25	29	V	(2),(3)
LED Power Consumption	P_{LED}	-	--	2.24	W	(2),(3)
LED Forward Voltage	V_F	2.9	3.3	3.5	V	(2)
LED Forward Current	I_F	-	20	-	mA	
LED Life Time	LT	30,000	-	-	Hours	(1)(2)

Note (1) The LED life time define as the estimated time to 50% degradation of initial luminous.

Note (2) Operating temperature 25°C, humidity 55%RH.

Note (3) A higher LED power supply voltage will result in better power efficiency. Keep the V_{LED} between 2.9V and 3.5V is strongly recommended.

Figure 8 LED Rush Current Measure Condition

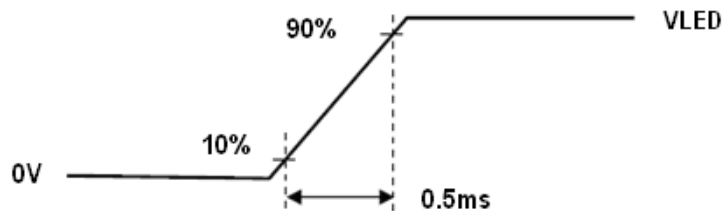

Table4 Backlight Connector Type

Item	Description
Manufacturer / Type	Don wan sheng Lan / 12005TOP-5H
Mating Receptacle / Type (Reference)	12005H00-2P-L-HF

Table 5 Backlight Connector Pin Assignment

Pin No.	Symbol	Description
1	LED-Pin1	GND Colour white(-)
2	LED-pin2	LED Power supply Color Black (+)

Document Name	M080AWP4 R0 Module Product Specification			Page 11 of 27	
Document No.		Made/Revised Date	2015/08/11	Ver.	04

6.0 Electrical Characteristics

6.1 Interface Connector

Table 6 Signal Connector Type

Item	Description
Manufacturer / Type	FH28-60S-0.5SH (HIROSE or equivalent), 60pin, pitch = 0.5mm

Table 7 Signal Connector Pin Assignment

Pin No.	Symbol	Description
1	AGND	Analog Ground
2	AVDD	Analog Power
3	VCC	Digital Power
4	R0	Data Input(LSB)
5	R1	Date Input
6	R2	Date Input
7	R3	Date Input
8	R4	Date Input
9	R5	Date Input
10	R6	Date Input
11	R7	Data Input(MSB)
12	G0	Data Input(LSB)
13	G1	Date Input
14	G2	Date Input
15	G3	Date Input
16	G4	Date Input
17	G5	Date Input
18	G6	Date Input
19	G7	Data Input(MSB)
20	B0	Data Input(LSB)

Document Name	M080AWP4 R0 Module Product Specification			Page 12 of 27	
Document No.		Made/Revised Date	2015/08/11	Ver.	04

Pin No.	Symbol	Description
21	B1	Date Input
22	B2	Date Input
23	B3	Date Input
24	B4	Date Input
25	B5	Date Input
26	B6	Date Input
27	B7	Data Input(MSB)
28	DCLK	Clock Input
29	DE	Data Enable signal
30	HSD	Horizontal sync input. Negative polarity
31	VSD	Vertical sync input. Negative polarity
32	MODE3	DE/SYNC mode select .normally pull high H:DE mode .L:HSD/VSD mode
33	RSTB	Global reset pin. Active low to enter reset state. suggest to connecting with an RC reset circuit for stability .normally pull high.
34	STBYB	Standby mode, normally pull high STBYB="1",normal operation STBYB="0",timming control , source driver will turn off, all output are high-Z
35	SHLR	Source right or left sequence control .SHLR="L", shift left: last data=S1<-S2...S1200=first data ; SHLR="H", shift right :first data=S1->S2...S1200=last data
36	VCC	Digital Power
37	UPDN	gate up or down scan control. UPDN="L" , DOWN shift :G1->G2...->G480 ; UPDN="H", up shift: G1<-G2...<-G480
38	GND	Digital Ground
39	AGND	Analog Ground
40	AVDD	Analog Power

Document Name	M080AWP4 R0 Module Product Specification			Page 13 of 27	
Document No.		Made/Revised Date	2015/08/11	Ver.	04

Pin No.	Symbol	Description
41	VCOM	For external VCOM DC input (Adjustable)
42	DITH	Dithering setting DITH="H" 6bit resolution (last 2 bits of input data truncated) (default setting), DITH="L" 8bit resolution
43	NC	Not connect
44	NC	Not connect
45	V10	Gamma correction voltage reference
46	V09	Gamma correction voltage reference
47	V08	Gamma correction voltage reference
48	V07	Gamma correction voltage reference
49	V06	Gamma correction voltage reference
50	V05	Gamma correction voltage reference
51	V04	Gamma correction voltage reference
52	V03	Gamma correction voltage reference
53	V02	Gamma correction voltage reference
54	V01	Gamma correction voltage reference
55	Bist	LCD Panel Self-Test Enable
56	VGH	Positive Power for TFT
57	VCC	Digital Power
58	VGL	Negative Power for TFT
59	GND	Digital Ground
60	NC	Not connect

6.2 Power Supply Voltage

Item	Min.	Typ.	Max.	Unit
Avdd	11.85	12	12.15	V
Vcom	3.5	4	4.5	V
VGH	20	22	24	V
VGL	-8.5	-7	-5.5	V

Document Name	M080AWP4 R0 Module Product Specification			Page 14 of 27	
Document No.		Made/Revised Date	2015/08/11	Ver.	04

6.3 Gamma Reference Voltage

Gamma Voltage	Unit(V)
V1	10.40
V2	8.169
V3	7.73
V4	7.28
V5	5.568
V6	5.09
V7	3.14
V8	2.752
V9	2.096
V10	0.35

Note: Vcom must be adjusted to optimize display quality: Crosstalk, Contrast Ratio etc.

Document Name	M080AWP4 R0 Module Product Specification			Page 15 of 27	
Document No.		Made/Revised Date	2015/08/11	Ver.	04

7.0 Interface Timings

7.1 Timing Characteristics

Synchronization method should be DE mode.

Table 8 Interface Timings

Item	Symbol	Min	Typ	Max	Unit
DCLK cycle time	Tcph	25	-	-	ns
DCLK frequency	Fclk	-	30	40	MHz
DCLK pulse duty	Tcwh	40	50	60	%
VSD setup time	Tvst	8	-	-	ns
VSD hold time	Tvhd	8	-	-	ns
HSD setup time	Thst	8	-	-	ns
HSD hold time	Thhd	8	-	-	ns
Data setup time	Tdsu	8	-	-	ns
Data hold time	Tdhd	8	-	-	ns
DE setup time	Tesu	8	-	-	ns
DE hold time	Tehd	8	-	-	ns
Horizontal display area	Thd	800			Tcph
HSD period time	Th	889	928	1143	Tcph
HSD pulse width	Thpw	1	48	255	Tcph
HSD back porch	Thb	-	40	-	Tcph
HSD front porch	Thfp	1	40	255	Tcph
Vertical display area	Tvd	480			Th
VSD period time	Tv	513	525	767	Th
VSD pulse width	Tvpw	3	3	255	Th
VSD back porch	Tvb	-	29	-	Th
VSD front porch	Tvfp	1	13	255	Th

Note: H Blanking Time and V Blanking Time can not be changed at every frame.

Document Name	M080AWP4 R0 Module Product Specification			Page 16 of 27	
Document No.		Made/Revised Date	2015/08/11	Ver.	04

Figure 9 Timing Characteristics

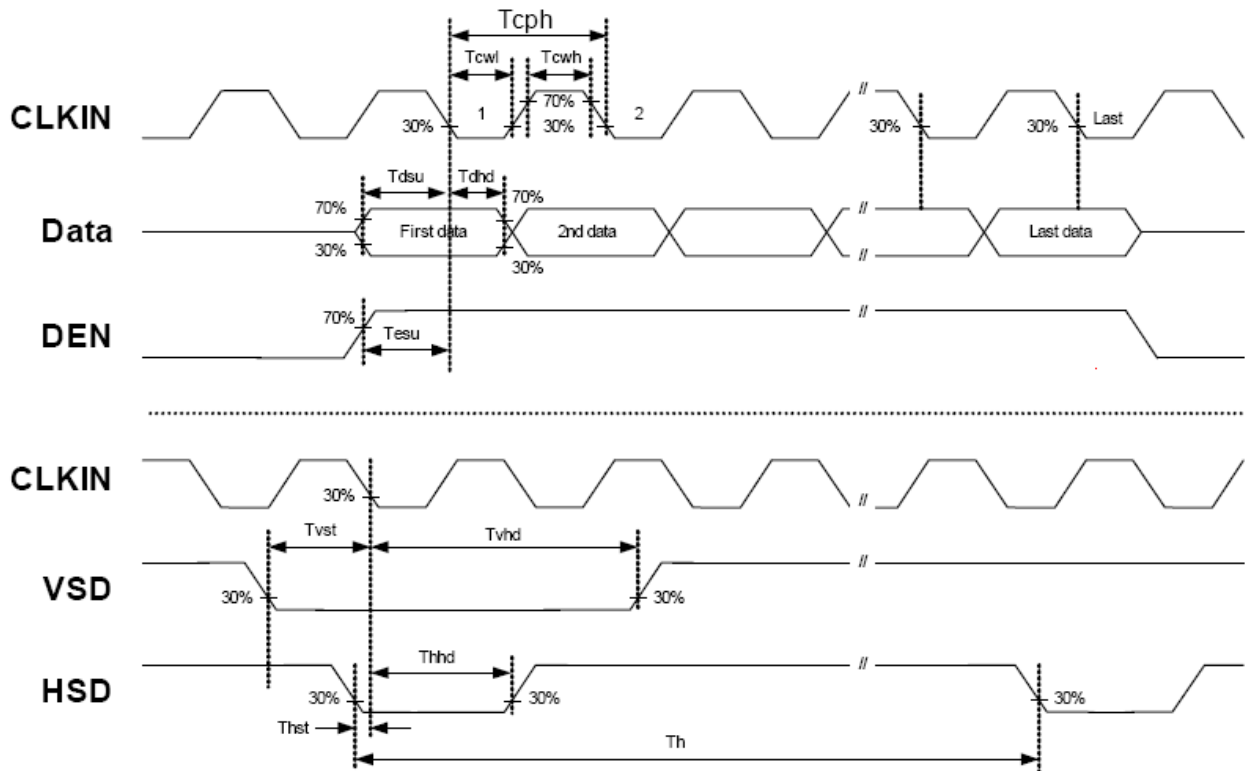
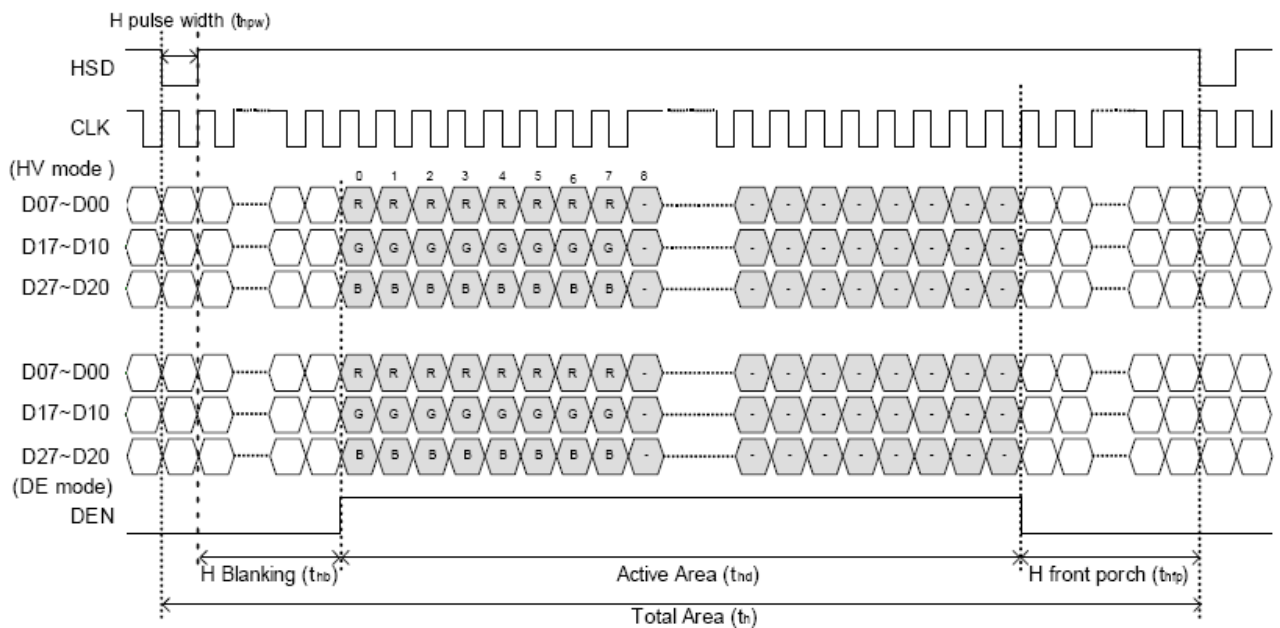
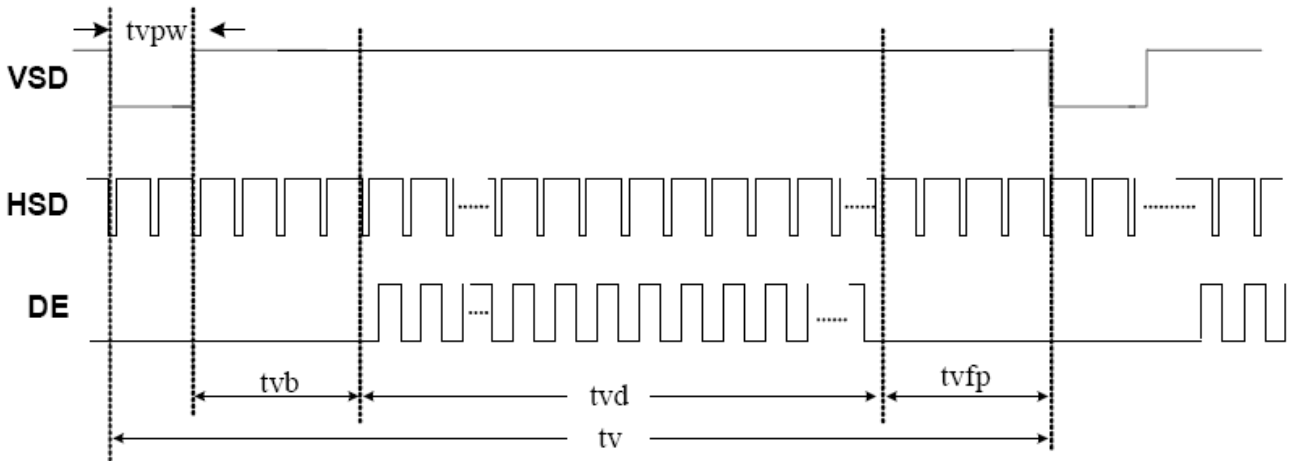

Figure 10 Horizontal Display Timing Range



Document Name	M080AWP4 R0 Module Product Specification			Page 17 of 27	
Document No.		Made/Revised Date	2015/08/11	Ver.	04

Figure 11 Vertical Timing



Note: TES is data enable signal setup time.

8.0 Power Consumption

Input power specifications are as follows.

Table 9 Power Consumption

Item	Symbol	Min.	Typ.	Max.	Units	Note	
LCD Drive Voltage (Logic)	VDD	3.0	3.3	3.6	V	(2), (4)	
VDD Current	Black Pattern	IDD	-	-	0.25	A	(3),(4),(6)
VDD Power Consumption	Black Pattern	PDD	-	-	0.7	W	
Rush Current	Irush	-	-	1.5	A	(1),(4),(5)	
Allowable Logic/LCD Drive Ripple Voltage	VDDrp	-	-	200	mV	(4)	

Note (1) Measure Condition

Figure 12 VDD Rising Time

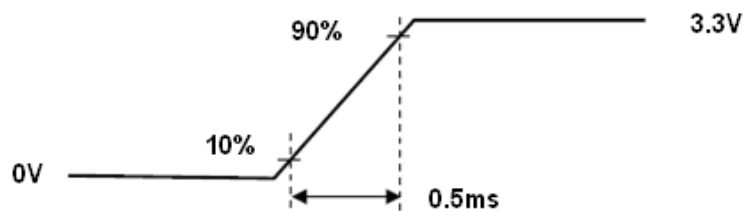

Note (2) VDD Power Dip Condition

If $V_{TH} < VDD \leq V_{min}$, then $t_d \leq 10ms$; when the voltage return to normal our panel must revive

Document Name	M080AWP4 R0 Module Product Specification			Page 18 of 27	
Document No.		Made/Revised Date	2015/08/11	Ver.	04

automatically.

Figure 13 VDD Power Dip

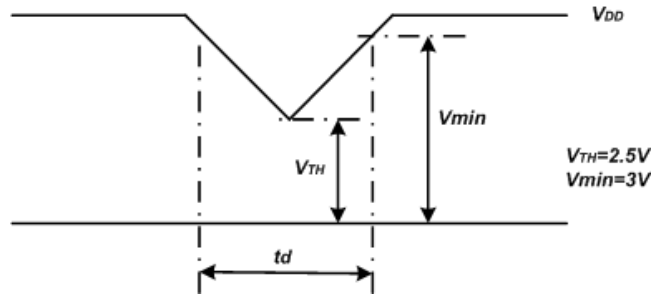

Note (3) Frame Rate=60Hz, VDD=3.2V,DC Current.

Note (4) Operating temperature 25°C, humidity 55%RH.

Note (5) The reference measurement circuit of rush current.

Figure 14 the circuit of rush current.

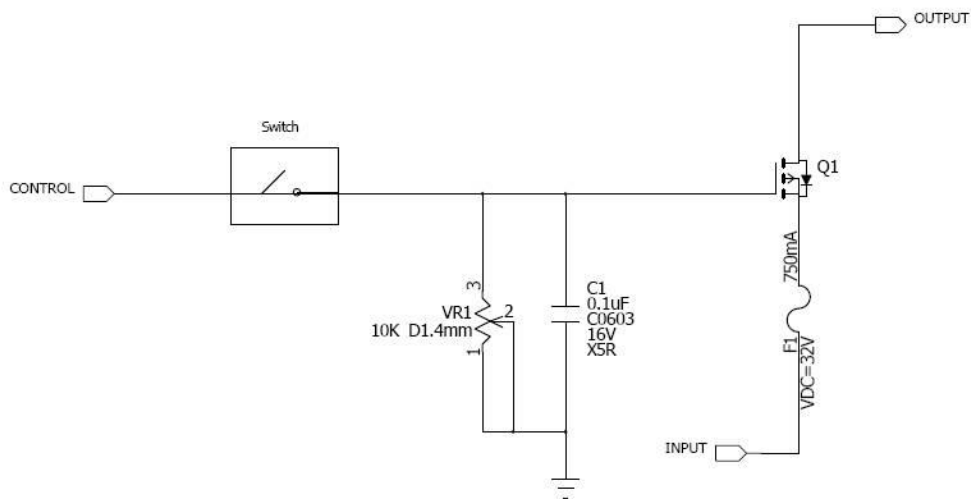

Document Name	M080AWP4 R0 Module Product Specification			Page 19 of 27	
Document No.		Made/Revised Date	2015/08/11	Ver.	04

9.0 Power ON/OFF Sequence

VDD power on/off sequence is as follows. Interface signals are also shown in the chart. Signals from any system shall be Hi- resistance state or low level when VDD is off.

Figure 15 Power Sequence

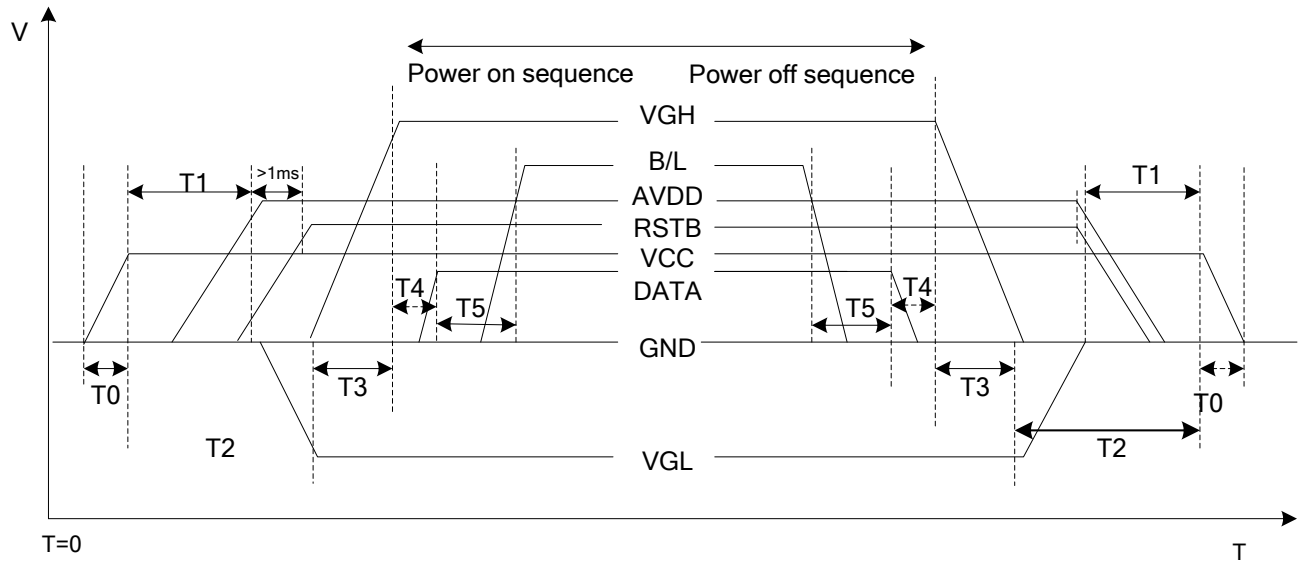

Table 10 Power Sequencing Requirements

Item	Min	Typ	Max	Unit
T0	0.5	-	20	[ms]
T1	16	-	-	[ms]
T2	20	-	-	[ms]
T3	10	-	-	[ms]
T4	10	-	50	[ms]
T5	50	-	-	[ms]

Document Name	M080AWP4 R0 Module Product Specification			Page 20 of 27	
Document No.		Made/Revised Date	2015/08/11	Ver.	04

10.0 Mechanical Characteristics

10.1 Outline Drawing

Figure 16 Reference Outline Drawing (Front)

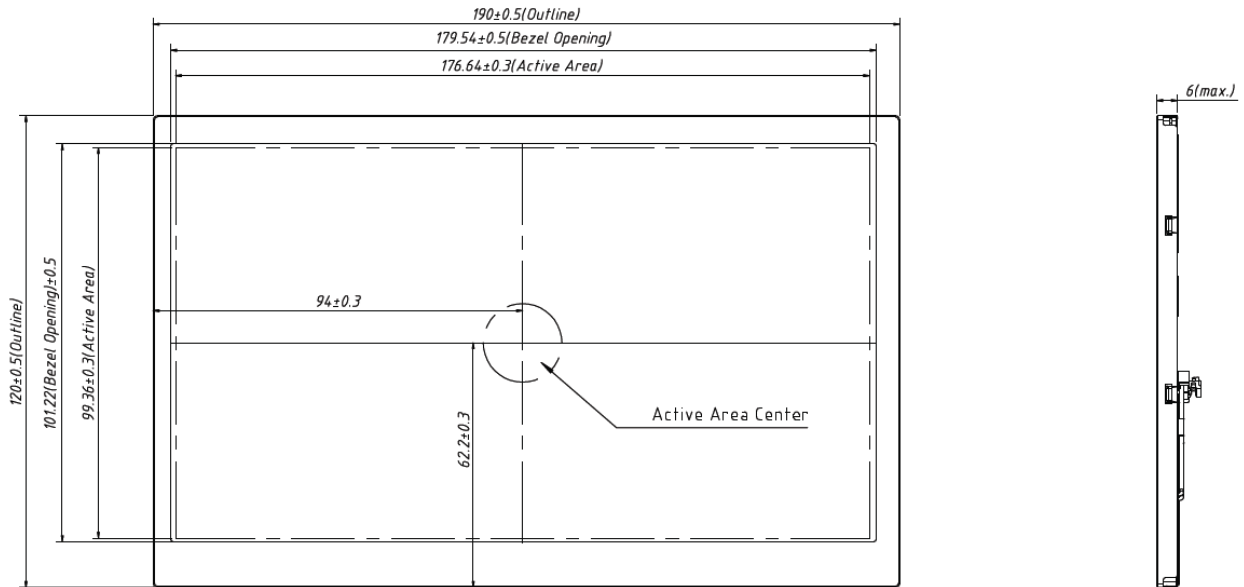

Document Name	M080AWP4 R0 Module Product Specification			Page 21 of 27	
Document No.		Made/Revised Date	2015/08/11	Ver.	04

Figure 17 Reference Outline Drawing (Side)

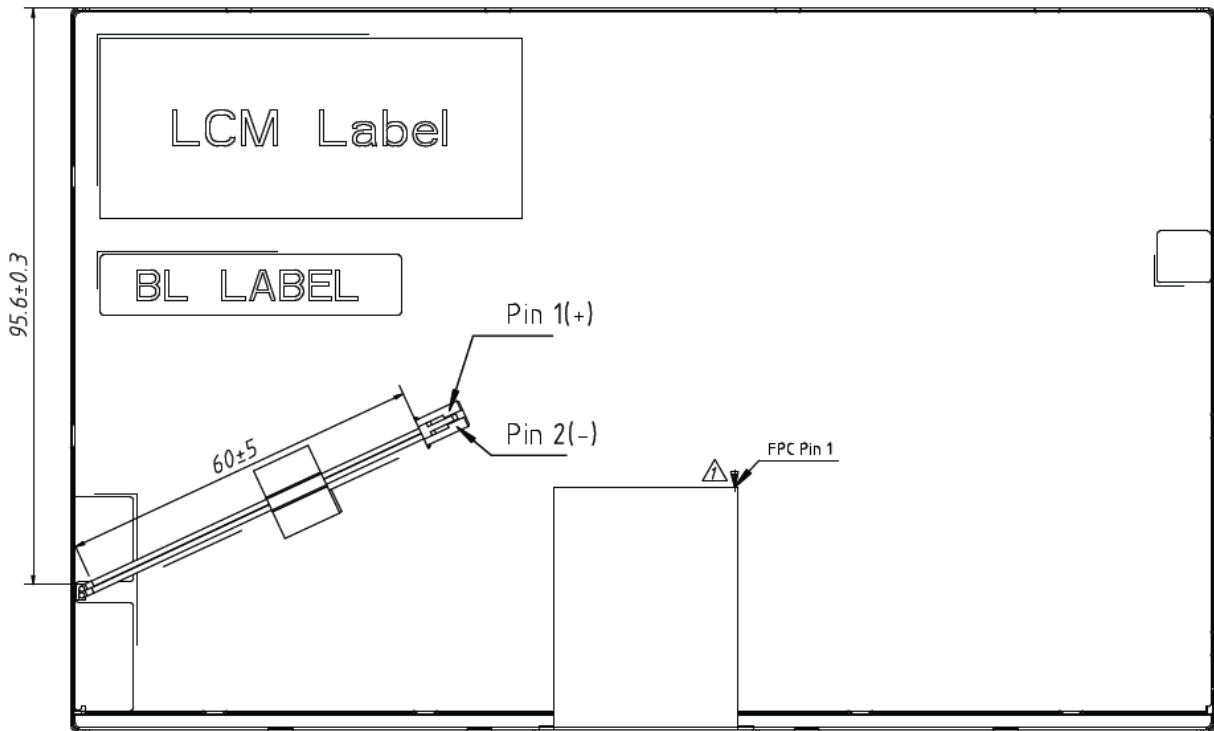

10.2 Dimension Specifications

Table 11 Module Dimension Specifications

Item	Min.	Typ.	Max.	Units
Width	189.5	190	190.5	mm
Height	119.5	120	120.5	mm
Thickness	-	5.0	6.0	mm
Weight	-	-	220	g
BM : a-b & c-d	≤1.0			mm

Document Name	M080AWP4 R0 Module Product Specification			Page 22 of 27	
Document No.		Made/Revised Date	2015/08/11	Ver.	04

Figure 18 BM Area

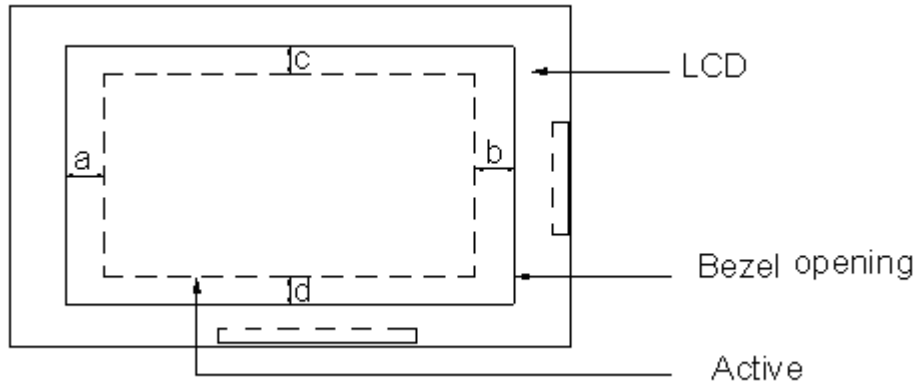

Document Name	M080AWP4 R0 Module Product Specification			Page 23 of 27	
Document No.		Made/Revised Date	2015/08/11	Ver.	04

11.0 Package Specification

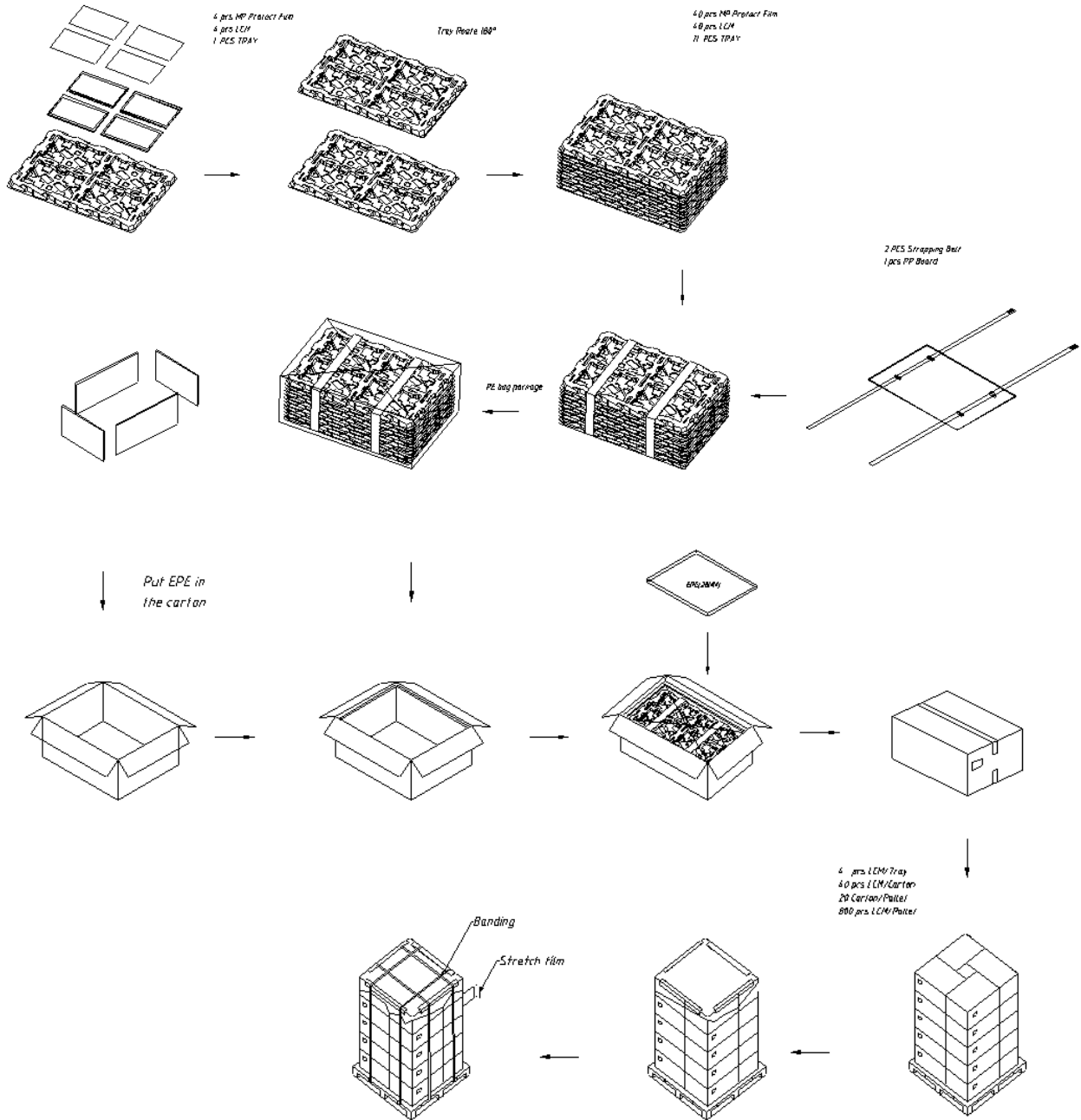

Components Material	LCM	Tray	MP Protect Film	PP Board	Top&Bottom EPE	Left&Right EPE	Front&Back EPE	PE Bag	Strapping Belt	Carton Label	Carton
Matrrial Size(mm)		520*345*22	184*108*0.23	520*345*5	560*385*20	345*200*20	560*200*20	(550+200)*600	(1100+100)*25	80*40	575*400*260
Amount	40Pcs/Carton	11Pcs/Carton	40Pcs/Carton	1Pcs/Carton	2Pcs/Carton	2Pcs/Carton	2Pcs/Carton	1Pcs/Carton	2Pcs/Carton	1Pcs/Carton	1Pcs/Carton

Document Name	M080AWP4 R0 Module Product Specification			Page 24 of 27	
Document No.		Made/Revised Date	2015/08/11	Ver.	04

12.0 Reliability Conditions

Item	Package	Test Conditions	Note
High Temp. Operating	Module	85°C, 500hrs	(1),(2),(3),(4),(5)
High Temp. Storage		95°C, 500hrs	(1),(3),(4),(5)
Low Temp. Operating		-30°C, 500hrs	(1),(2),(3),(4),(5)
Low Temp. Storage		-40°C, 500hrs	(1),(3),(4),(5)
High Temp. High Humidity Operating		60°C, 90%RH, 500hrs	(1),(2),(3),(4),(5)
High Temp. High Humidity Storage		60°C, 90%RH, 500hrs	(1),(3),(4),(5)
Thermal Shock Non-operating Test		-40°C-85°C, 60min/each cycle, 200cyc	(1),(3),(4),(5)
Thermal Cycle		-30~85°C, 20%~90%RH, 4cycle, 29hrs/cycle (25°C/50%→85°C/20%, 1hrs; 85°C/20%, 6hrs; 85°C/20%→60°C/90%, 1hrs; 60°C/90%, 6hrs 60°C/90%→-30°C/0%, 2hrs; -30°C/0%, 12hrs; -30°C/0%→25°C/50%, 1hrs;)	(1),(2),(3),(4),(5)

Note (1) There is no function defect and occurrence of any new defective shall not be allowed.

Note (2) In Operating test, the B/L voltage and current must be in spec.

Note (3) All the judgments are under normal temperature and the sample need to be static more than 2 hours in the normal temperature before judge.

Note (4) During measurement, the condensation water or remains shall not be allowed.

Note (5) There is no display function fail issue occurred, all the cosmetic specification is judged before the reliability stress.

Document Name	M080AWP4 R0 Module Product Specification			Page 25 of 27	
Document No.		Made/Revised Date	2015/08/11	Ver.	04

13.0 Lot Mark

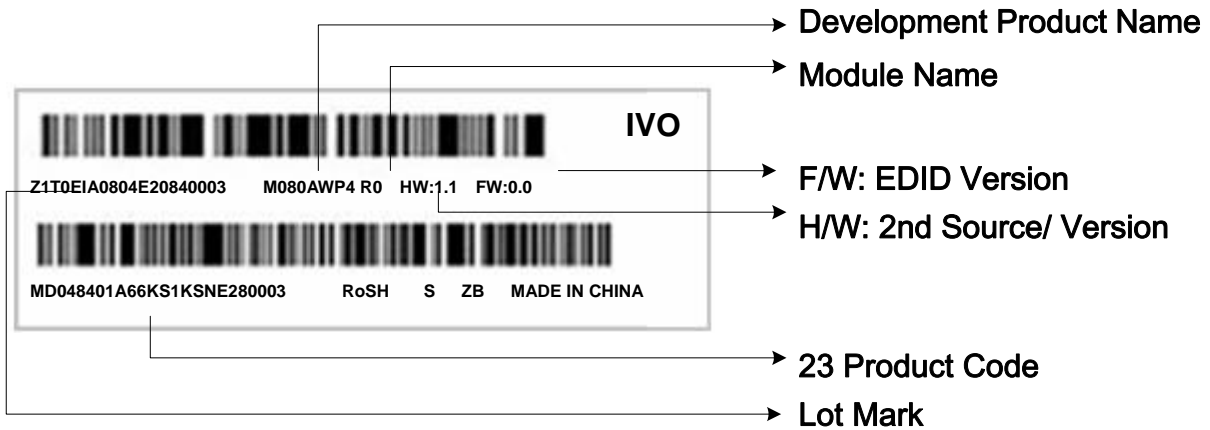

Note: This picture is only an example.

13.1 20 Lot Mark

1	2	3	4	5	6	7	8	9	10	11	12	13	14	15	16	17	18	19	20
---	---	---	---	---	---	---	---	---	----	----	----	----	----	----	----	----	----	----	----

Code 1,2,4,5,6,7,8,9,10,11,16: IVO internal flow control code.

Code 3: Production Location.

Code 12: Production Year.

Code 13: Production Month.

Code 14,15: Production Day.

Code 17,18,19,20: Serial Number.

13.2 23 Product Barcode

1	2	3	4	5	6	7	8	9	10	11	12	13	14	15	16	17	18	19	20	21	22	23
---	---	---	---	---	---	---	---	---	----	----	----	----	----	----	----	----	----	----	----	----	----	----

Code 1,2: Manufacture District.

Code 3,4,5,6,7: IVO internal module name.

Code 8,9,10,13,16: IVO internal flow control code.

Code 11,12: Cell location Suzhou, China defined as "KS".

Code 14 ,15: Module location Kunshan, China defined as "KS"; Yangzhou, China defined as "YZ"; Shenzhen, China defined as "SE"; Zhuhai, China defined as "ZH"; Suzhou, China defined as "SZ".

Code 17,18,19 : Year, Month, Day refer to Note(1), Note(2) and Note(3).

Note (1) Production Year

Year	2006	2007	2008	2009	2010	2011	2012	2013	2035
Mark	6	7	8	9	A	B	C	D	Z

Note (2) Production Month

Document Name	M080AWP4 R0 Module Product Specification				Page 26 of 27			
Document No.		Made/Revised Date	2015/08/11	Ver.	04			

Month	Jan.	Feb.	Mar.	Apr.	May.	Jun.	Jul.	Aug.	Sep.	Oct	Nov.	Dec.
Mark	1	2	3	4	5	6	7	8	9	A	B	C

Note (3) Production Day: 1~V.

Code 20~23 : Serial Number.

14.0 General Precaution

14.1 Use Restriction

This product is not authorized for use in life supporting systems, aircraft navigation control systems, military systems and any other application where performance failure could be life-threatening or otherwise catastrophic.

14.2 Handling Precaution

- (1) Please mount LCD module by using mounting holes arranged in four corners tightly.
- (2) Do not disassemble or modify the module. It may damage sensitive parts inside LCD module, and may cause scratches or dust on the display. IVO does not warrant the module, if customers disassemble or modify the module.
- (3) If LCD panel is broken and liquid crystal spills out, do not ingest or inhale liquid Crystal, and do not contact liquid crystal with skin. If liquid crystal contacts mouth or eyes, rinse out with water immediately. If liquid crystal contacts skin or cloths, wash it off immediately with alcohol and Rinse thoroughly with water.
- (4) Disconnect power supply before handling LCD module
- (5) Refrain from strong mechanical shock and /or any force to the module.
- (6) Do not exceed the absolute maximum rating values, such as the supply voltage variation, input voltage variation, variation in parts' parameters, environmental temperature; etc otherwise LCD module may be damaged. It's recommended employing protection circuit for power supply.
- (7) Do not touch, push or rub the polarizer with anything harder than HB pencil lead. Use fingerstalls of soft gloves in order to keep clean display quality, when Persons handle the LCD module for incoming inspection or assembly.
- (8) When the surface is dusty, please wipe gently with absorbent cotton or other soft Material. When cleaning the adhesives, please use absorbent cotton wetted with a little Petroleum benzene or other adequate solvent.
- (9) Wipe off saliva or water drops as soon as possible. If saliva or water drops Contact with polarizer for a long time, they may cause deformation or color Fading.
- (10) Protection film must remove very slowly from the surface of LCD module to Prevent from electrostatic occurrence.
- (11) Because LCD module uses CMOS-IC on circuit board and TFT-LCD panel, it is Very weak to electrostatic discharge, Please be careful with electrostatic Discharge .Persons who handle the module should be grounded through adequate methods.
- (12) Do not adjust the variable resistor located on the module.

14.3 Storage Precaution

- (1) Please do not leave LCD module in the environment of high humidity and high temperature for a long time.
- (2) The module shall not be exposed under strong light such as direct sunlight. Otherwise, Display characteristics may be changed.
- (3) The module should be stored in a dark place. It is prohibited to apply sunlight or fluorescent light in storage.

Document Name	M080AWP4 R0 Module Product Specification			Page 27 of 27	
Document No.		Made/Revised Date	2015/08/11	Ver.	04

14.4 Operation Precaution

- (1) Do not connect or disconnect the module in the "Power On" condition.
- (2) Power supply should always be turned on/off by "Power on/off sequence"
- (3) Module has high frequency circuits. Sufficient suppression to the electromagnetic interference should be done by system manufacturers. Grounding and shielding methods may be important to minimize the interference.
- (4) After installation of the TFT Module into an enclosure, do not twist nor bend the TFT Module even momentary. At designing the enclosure, it should be taken into consideration that no bending/twisting forces are applied to the TFT Module from outside. Otherwise the TFT Module may be damaged.

14.5 Others

- (1) Ultra-violet ray filter is necessary for outdoor operation.
- (2) Avoid condensation of water which may result in improper operation or disconnection of electrode.
- (3) If the module keeps displaying the same pattern for a long period of time, the image may be "sticked" to the screen.
- (4) This module has its circuitry PCB's on the rear side and should be handled carefully in order not to be stressed.

14.6 Disposal

When disposing LCD module, obey the local environmental regulations.