

Document Title	M080AWT8 R1 Customer Approval Specification	Page No.	1/28
Document No.		Issue date	2016/01/07
		Revision	02

Customer Approval Specification

Customer:

Product Name: M080AWT8 R1

Document Issue Date: 2016/01/07

Customer	InfoVision Optoelectronics
<p><u>SIGNATURE</u></p> <p>_____</p> <p>_____</p> <p>_____</p> <p>Please return 1 copy for your confirmation with your signature and comments.</p>	<p><u>SIGNATURE</u></p> <p>REVIEWED BY CQM</p> <p>_____</p> <p>PREPARED BY FAE</p> <p>_____</p>

Note: 1. Please contact InfoVision Company before designing your product based on this product.

2. The information contained herein is presented merely to indicate the characteristics and performance of our products. No responsibility is assumed by IVO for any intellectual property claims or other problems that may result from application based on the module described herein.

FQ-7-30-0-009-03D

Document Title	M080AWT8 R1 Customer Approval Specification	Page No.	2/28
Document No.		Issue date	2016/01/07
		Revision	02

CONTENTS

1.0 GENERAL DESCRIPTIONS	3
2.0 ABSOLUTE MAXIMUM RATINGS	5
3.0 OPTICAL CHARACTERISTICS	6
4.0 ELECTRICAL CHARACTERISTICS	9
5.0 MECHANICAL CHARACTERISTICS	21
6.0 RELIABILITY CONDITIONS	24
7.0 PACKAGE SPECIFICATION	25
8.0 LOT MARK	26
9.0 GENERAL PRECAUTION	27

Document Title	M080AWT8 R1 Customer Approval Specification		Page No.	3/28	
Document No.		Issue date	2016/01/07	Revision	02

1.0 General Descriptions

1.1 Introduction

The M080AWT8 R1 is a color active matrix thin film transistor (TFT) liquid crystal display (LCD) that uses amorphous silicon TFT as a switching device. This model is composed of a TFT LCD panel, a driver circuit and a backlight system. This TFT LCD has a 8.0 inch diagonally measured active display area with WSVGA resolution (1,024 horizontal by 600 vertical pixels array).

1.2 Features

- Supported WSVGA Resolution
- LVDS Interface
- Compatible with RoHS Standard

1.3 Product Summary

Items	Specifications	Unit
Screen Diagonal	8.0	inch
Active Area (H x V)	176.64 x 99.36	mm
Number of Pixels (H x V)	1,024 x 600	-
Pixel Pitch (H x V)	0.1725 x 0.1656	mm
Pixel Arrangement	R.G.B. Vertical Stripe	-
Display Mode	Normally White	-
White Luminance ☆	670(Typ.)	cd /m ²
Contrast Ratio ☆	800 (Typ.)	-
Response Time	16 (Typ.) 25(Max)	ms
Input Voltage	3.3 (Typ.)	V
Power Consumption	4.6 (Max.)	W
Weight	240 (Max.)	g
Outline Dimension (H x V x D)	192.8(Typ.) x 116.9(Typ.) x6.4 (Typ.)	mm
Electrical Interface (Logic)	LVDS	-
Support Color	16.7M	-
NTSC	72 (Typ.)	%
Viewing Direction	6 O'clock	-
Surface Treatment	Anti-glare	-

Document Title	M080AWT8 R1 Customer Approval Specification	Page No.	4/28
Document No.		Issue date	2016/01/07
		Revision	02

1.4 Functional Block Diagram

Figure 1 shows the functional block diagram of the LCD module.

Figure 1 Block Diagram

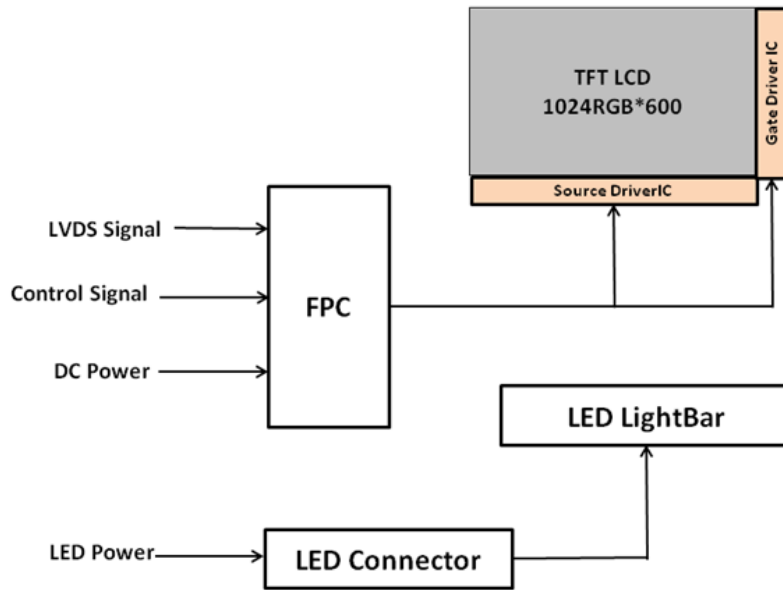

1.5 Pixel Mapping

Figure2 Pixel Mapping

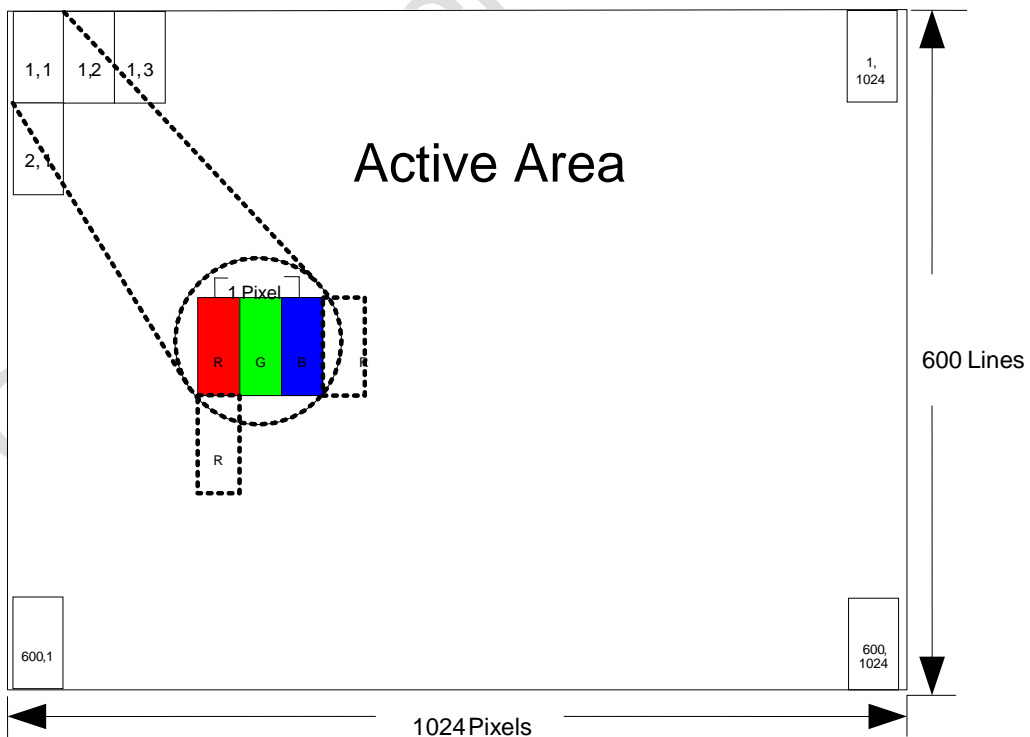

Document Title	M080AWT8 R1 Customer Approval Specification			Page No.	5/28
Document No.		Issue date	2016/01/07	Revision	02

2.0 Absolute Maximum Ratings

Table 1 Electrical & Environment Absolute Rating

Item	Symbol	Min.	Typ.	Max.	Unit	Note
Digital Supply Voltage	V_{DD}	-0.5	-	3.9	V	(1),(2)
Logic Input Signal Voltage	V_{Signal}	-0.5	-	3.9	V	
Operating Temperature	T_{OP}	-30	-	85	°C	(3),(4),(5),(6)
Storage Temperature	T_{ST}	-40	-	90	°C	

Note (1) Permanent damage may occur to the LCD module if beyond this specification. Functional operation should be restricted to the conditions described under normal operating conditions.

Note (2) Operating temperature 25°C, humidity 55%RH.

Note (3) ($T \leq 40^\circ\text{C}$) Note static electricity. Maximum wet bulb temperature at 39°C or less. ($T > 40^\circ\text{C}$) No condensation.

Note (4) There is a possibility of causing deterioration in the irregularity and others of the screen and the display fineness though the liquid crystal module doesn't arrive at destruction when using it at 85~90°C or -40~-30°C.

Note (5) There is a possibility of causing the fineness deterioration by the prolonged use in the (high temperature) humidity environment (80%RH or more).

Note (6) In the operating temperature item, the low temperature side is the ambient temperature regulations. The high temperature side is the panel surface temperature regulations.

Absolute Ratings of Environment of the LCD Module

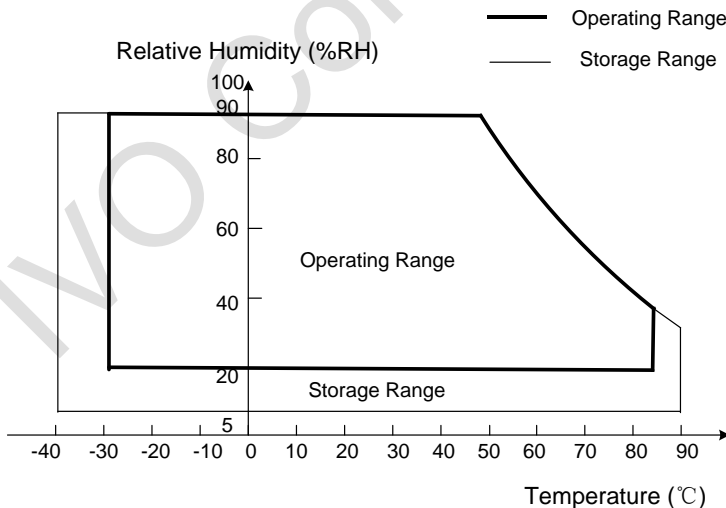

Document Title	M080AWT8 R1 Customer Approval Specification		Page No.	6/28	
Document No.		Issue date	2016/01/07	Revision	02

Note (7) half-sine; Frequency: 8Hz ~ 33Hz;Stroke: 1.3mm;Sweep: 2.9G 33.3Hz ~ 400Hz X,Z
 Cycle : 15 minutes;2 hrs for each direction of X,Z ; 4 hours for Y direction
 Note (8) 6ms, half sine wave, three times for X, Y, Z axis.

3.0 Optical Characteristics

The optical characteristics are measured under stable conditions as following notes.

Table 2 Optical Characteristics

Item	Conditions	Min.	Typ.	Max.	Unit	Note
Viewing Angle (CR>10) ☆	Horizontal	θ_{x+}	65	75	-	degree (1),(2),(3)
		θ_{x-}	65	75	-	
	Vertical	θ_{y+}	60	70	-	
		θ_{y-}	65	75	-	
Contrast Ratio ☆	Center	600	800	-	-	(1),(2),(4) $\theta_x=\theta_y=0^\circ$
Response Time	Rising + Falling	-	16	25	ms	(1),(2),(5) $\theta_x=\theta_y=0^\circ$
Color Chromaticity (CIE1931) ☆	Red x	Typ. -0.04	0.630	Typ. +0.04	-	(1),(2),(3) $\theta_x=\theta_y=0^\circ$
	Red y		0.358		-	
	Green x		0.302		-	
	Green y		0.641		-	
	Blue x		0.150		-	
	Blue y		0.059		-	
	White x		0.315		-	
	White y		0.335		-	
NTSC	-	67	72	-	%	(1),(2),(3) $\theta_x=\theta_y=0^\circ$
White Luminance ☆	Center Point	550	670	-	cd/m ²	(1),(2),(6) $\theta_x=\theta_y=0^\circ$
Luminance Uniformity	9 Points	75	80	-	%	(1),(2),(6) $\theta_x=\theta_y=0^\circ$

Note (1) Measurement Setup:

The LCD module should be stabilized at given temperature(25℃) for 15 minutes to avoid abrupt temperature change during measuring. In order to stabilize the luminance, the measurement should be executed after lighting backlight for 15 minutes in a windless room.

Document Title	M080AWT8 R1 Customer Approval Specification	Page No.	7/28
Document No.		Issue date	2016/01/07
		Revision	02

Figure 3 Measurement Setup

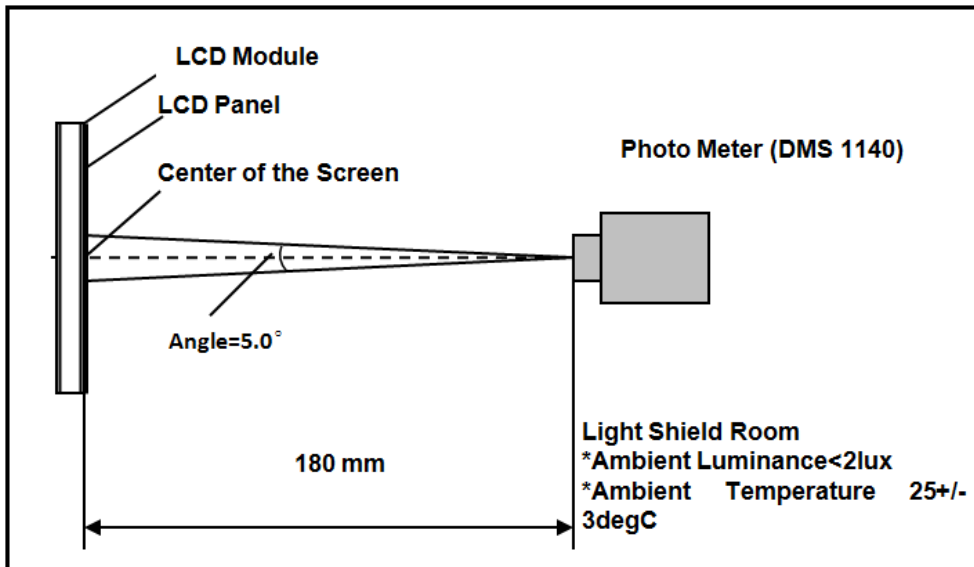

Note (2) The LED input parameter setting as:

I_LED: 420mA

Note (3) Definition of Viewing Angle

Figure 4 Definition of Viewing Angle

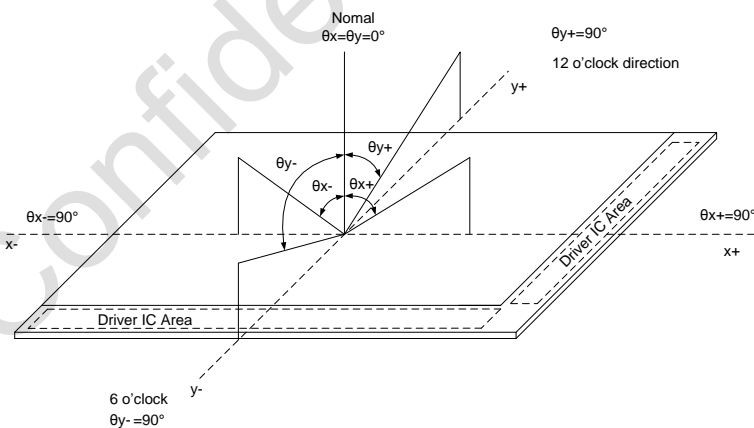

Note (4) Definition Of Contrast Ratio (CR)

The contrast ratio can be calculated by the following expression:

$$\text{Contrast Ratio (CR)} = L_{255} / L_0$$

L255: Luminance of gray level 255, L0: Luminance of gray level 0

Document Title	M080AWT8 R1 Customer Approval Specification	Page No.	8/28
Document No.		Issue date	2016/01/07
		Revision	02

Note (5) Definition Of Response Time (T_R , T_F)

Figure 5 Definition of Response Time

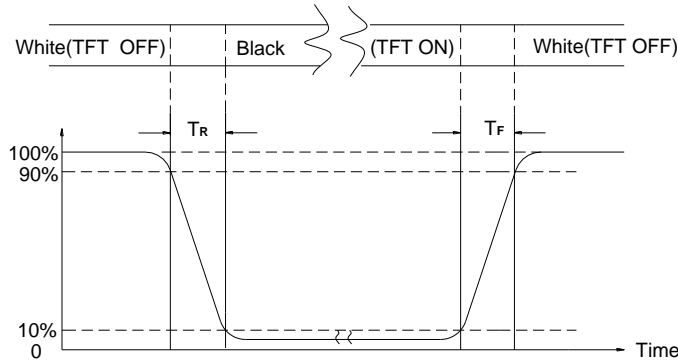

Note (6) Definition of Luminance Uniformity (Ref.: Active Area)

Measure the luminance of gray level 255 at 9 points.

Luminance Uniformity= $\text{Min.}(L1, L2, \dots L9) / \text{Max.}(L1, L2, \dots L9)$

H—Active Area Width, V—Active Area Height, L—Luminance

Figure 6 Measurement Locations of 9 Points

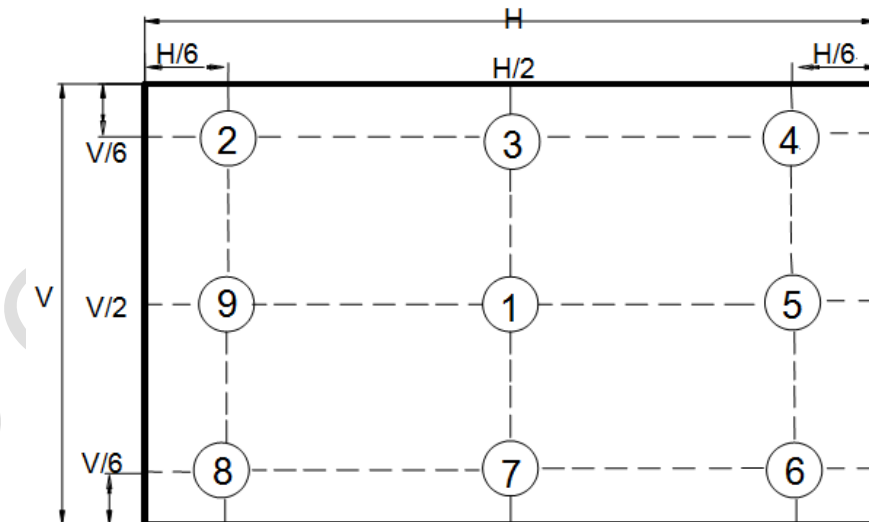

Document Title	M080AWT8 R1 Customer Approval Specification	Page No.	9/28
Document No.		Issue date	2016/01/07
		Revision	02

4.0 Electrical Characteristics

4.1 Interface Connector

Table 3 Signal Connector Type

Item	Description
Manufacturer/Type	AORORA:F32D-1A7Y-21040

Table 4 Signal Connector Pin Assignment

Pin No.	Symbol	Description	Remarks
1	VCOM	Common voltage	
2	DVDD	Digital power	
3	DVDD	Digital power	
4	NC	Not connect	
5	RESET	Global reset pin. Active low to enter reset state. Suggest to connecting with an RC reset circuit for stability. Normally pull high.(R=10kΩ,C=1uF)	
6	STBYB	Standby mode ,normally pull high STBYB ="1",normal operation STBYB ="0",timing control ,source driver will turn off,all output are high-Z	
7	GND	Ground	
8	NIND0	Negative LVDS differential data input	
9	PIND0	Positive LVDS differential data input	
10	GND	Ground	
11	NIND1	Negative LVDS differential data input	

昆山龙腾光电有限公司

IVO InfoVision Optoelectronics (Kunshan) Co.,LTD.

Document Title	M080AWT8 R1 Customer Approval Specification		Page No.	10/28	
Document No.		Issue date	2016/01/07	Revision	02

12	PIND1	Positive LVDS differential data input	
13	GND	Ground	
14	NIND2	Negative LVDS differential data input	
15	PIND2	Positive LVDS differential data input	
16	GND	Ground	
17	NINC	Negative LVDS differential clock input	
18	PINC	Positive LVDS differential clock input	
19	GND	Ground	
20	NIND3	Negative LVDS differential data input	
21	PIND3	Positive LVDS differential data input	
22	GND	Ground	
23	NC	Not connect	
24	NC	Not connect	
25	GND	Ground	
26	NC	Not connect	
27	NC	Not connect	
28	SELB	LVDS input data is 8 bits, SELB set to low	
29	AVDD	Power for Analog Circuit	
30	GND	Ground	
31	NC	Not connect	

Document Title	M080AWT8 R1 Customer Approval Specification		Page No.	11/28	
Document No.		Issue date	2016/01/07	Revision	02

32	NC	Not connect	
33	SHLR	Horizontal inversion	Note1
34	UPDN	Vertical inversion	Note1
35	VGL	Negative power for TFT	
36	NC	Not connect	
37	NC	Not connect	
38	VGH	Positive power for TFT	
39	NC	Not connect	
40	Bist	Normal operation/BIST pattern select. Normally pull low. When BIST=H: BIST. (CLK input is not needed.) When BIST=L: Normal operation. (Default)	System without the need to signal

Note1 : UPDN and SHLR control function

SHLR	UPDN	Data shifting
DVDD	GND	Left→Right , Up→Down(default)
GND	GND	Right→Left , Up→Down
DVDD	DVDD	Left→Right , Down→Up
GND	DVDD	Right→Left , Down→Up

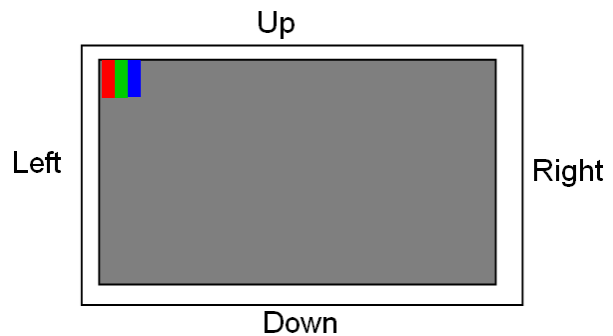

Power Supply Voltage

Item	Min.	Typ.	Max.	Unit
Avdd	10.8	11.0	11.2	V
Vcom	4.0	4.2	4.4	V
VGH	19	20	21	V
VGL	-7.8	-6.8	-5.8	V

Document Title	M080AWT8 R1 Customer Approval Specification		Page No.	12/28	
Document No.		Issue date	2016/01/07	Revision	02

Table 5 LED Connector Name / Designation

Item	Description
Manufacturer / Type	JST/BHSR-02VS-1
Mating Receptacle / Type (Reference)	JST/SMO2B-BHSS-1 or Compatible

Table 6 LED Connector Pin Assignment

Pin No.	Symbol	Description	Remarks
1	A	Anode	+
2	K	Cathode	-

Figure 7 LED Connector

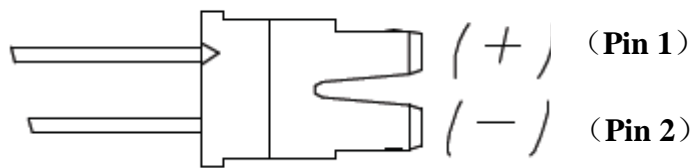

Document Title	M080AWT8 R1 Customer Approval Specification		Page No.	13/28	
Document No.		Issue date	2016/01/07	Revision	02

4.2 Signal Electrical Characteristics

4.2.1 Signal Electrical Characteristics For LVDS Receiver

The built-in LVDS receiver is compatible with (ANSI/TIA/TIA-644) standard.

Table 7 LVDS Receiver Electrical Characteristics

Parameter	Symbol	Min.	Typ.	Max.	Unit	Conditions
Differential Input High Threshold	V _{th}	-	-	+100	mV	V _{CM} =+1.2V
Differential Input Low Threshold	V _{tl}	-100	-	-	mV	V _{CM} =+1.2V
Magnitude Differential Input Voltage	V _{ID}	200	-	600	mV	-
Common Mode Voltage	V _{CM}	1.0	1.2	1.4	V	V _{th} - V _{tl} =200mA
Common Mode Voltage Offset	ΔV _{CM}	-50	-	+50	mV	V _{th} - V _{tl} =200mA

Note (1) Input signals shall be low or Hi- resistance state when VDD is off.

Note (2) All electrical characteristics for LVDS signal are defined and shall be measured at the interface connector of LCD.

Figure 8 Voltage Definitions

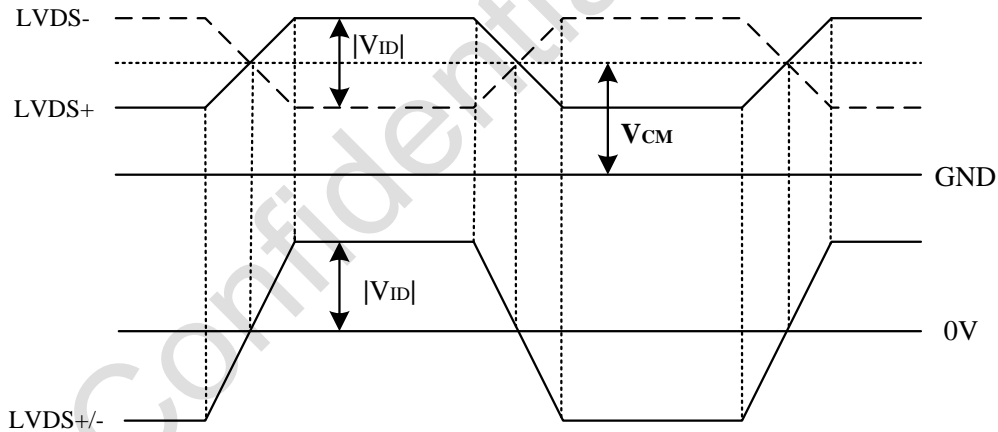

Document Title	M080AWT8 R1 Customer Approval Specification	Page No.	14/28
Document No.		Issue date	2016/01/07
		Revision	02

Figure 9 Measurement System

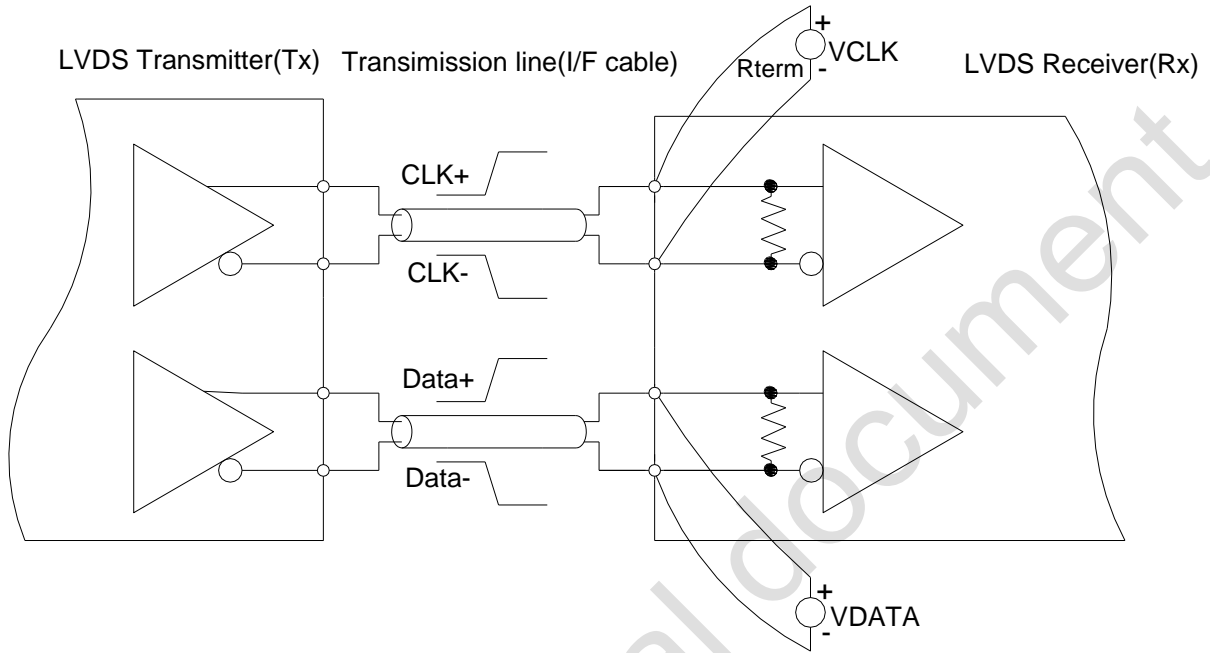
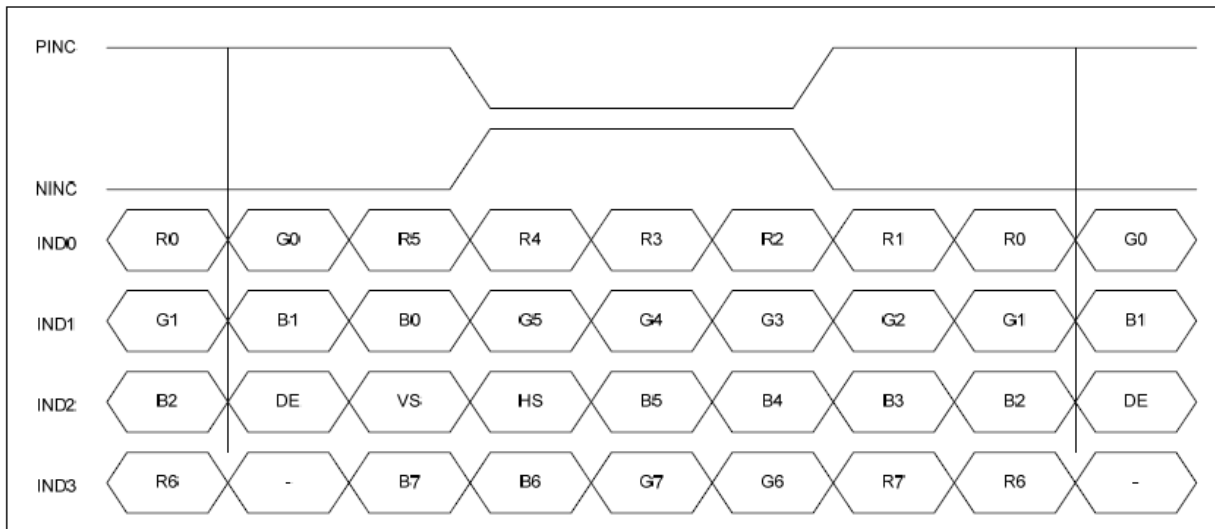

Figure 10 Data Mapping

Single 8 bit LVDS input



Document Title	M080AWT8 R1 Customer Approval Specification	Page No.	15/28
Document No.		Issue date	2016/01/07
		Revision	02

4.2.2 LVDS Receiver Internal Circuit

Figure 12 shows the internal block diagram of the LVDS receiver. This LCD module equips termination resistors for LVDS link.

Figure 11 LVDS Receiver Internal Circuit

8bit

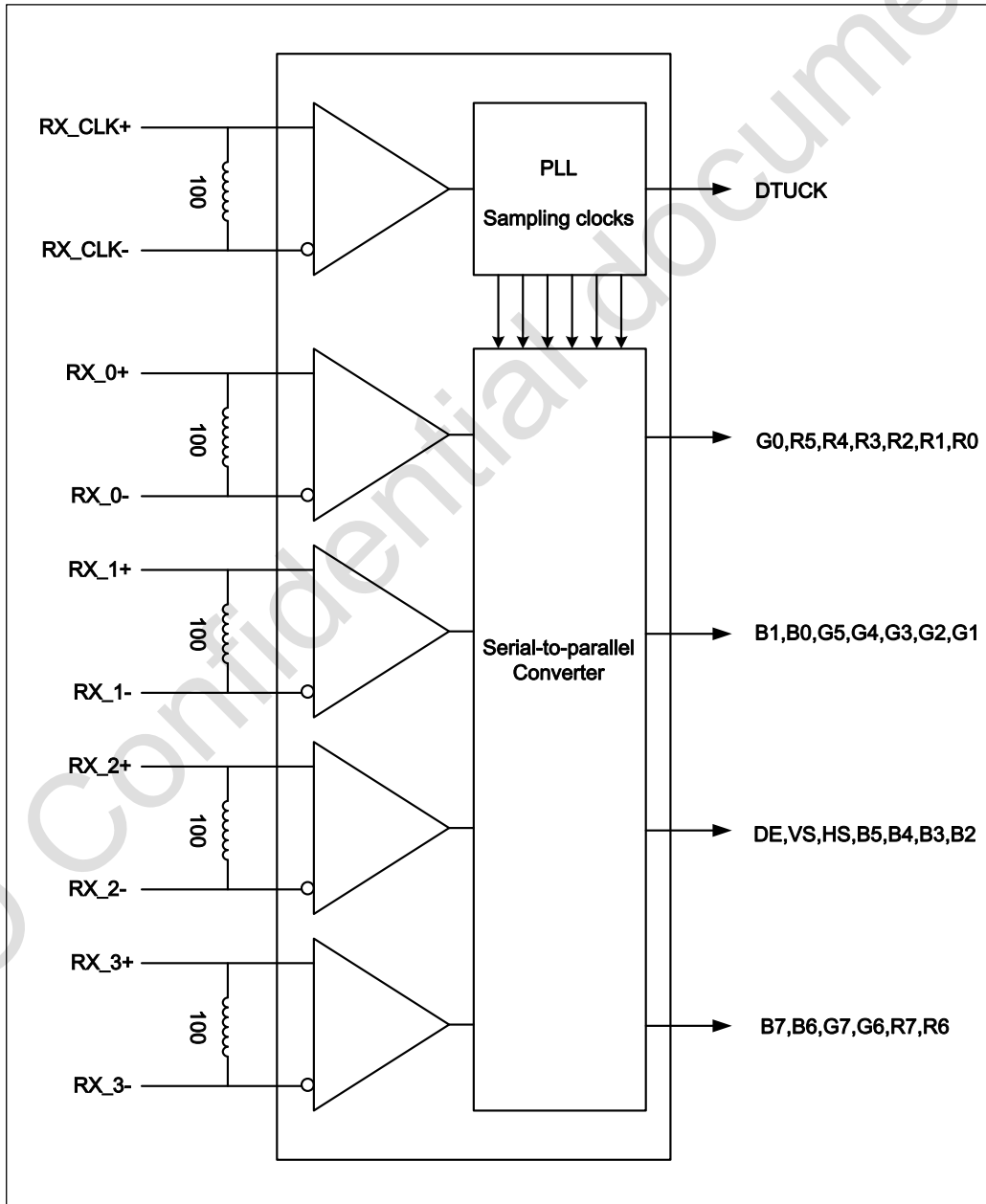

Document Title	M080AWT8 R1 Customer Approval Specification			Page No.	16/28
Document No.		Issue date	2016/01/07	Revision	02

4.3 Interface Timings

Table 8 Interface Timings

Parameter	Symbol	Min.	Typ.	Max.	Unit
LVDS Clock Frequency	f_{dck}	45	51.2	57	MHz
H Total Time	T_{hp}	1,324	1,344	1,364	Clocks
H Active Time	HA	1,024	1,024	1,024	Clocks
H Blanking Time	T_{HBlank}	300	320	340	Clocks
V Total Time	T_{vp}	625	635	645	Lines
V Active Time	VA	600	600	600	Lines
V Blanking Time	T_{VBlank}	25	35	45	Clocks
Frame Rate	F_v	50	60	65	Hz

4.4 Input Power Specifications

Input power specifications are as follows.

Table 9 Input Power Specifications

Parameter	Symbol	Min.	Typ.	Max.	Unit	Note	
System Power Supply							
LCD Drive Voltage (Logic)	D_{VDD}	3.0	3.3	3.6	V	(2), (4)	
VDD Current	Black Pattern	I_{DD}	-	-	0.09	A	(3),(4)
VDD Power Consumption	Black Pattern	P_{DD}	-	-	0.30	W	
Rush Current	I_{Rush}	-	-	1.5	A	(1),(4),(5)	
Allowable Logic/LCD Drive Ripple Voltage	V_{VDD-RP}	-	-	200	mV	(4)	
LED Power Supply							
LED Input Voltage	V_{LED}	8.4	9.6	10.2	V	(4),(6)	
LED Power Consumption	P_{LED}	-	-	4.3	W	(4),(6)	
LED Forward Voltage	V_F	2.8	3.2	3.4	V	(4)	
LED Forward Current	I_F	-	60	-	mA		
LED Life Time	LT	30,000	-	-	Hours	(4)(7)	

Document Title	M080AWT8 R1 Customer Approval Specification	Page No.	17/28
Document No.		Issue date	2016/01/07
		Revision	02

Note (1) Measure Condition

Figure 12 VDD Rising Time

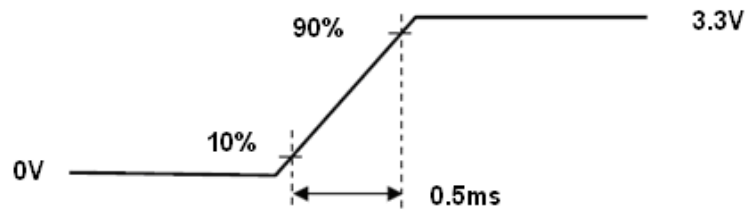

Note (2) VDD Power Dip Condition

$V_{TH} < V_{DD} \leq V_{min}$, $t_d \leq 10ms$ (a time of the voltage return to normal), our panel can revive automatically.

Figure 13 VDD Power Dip

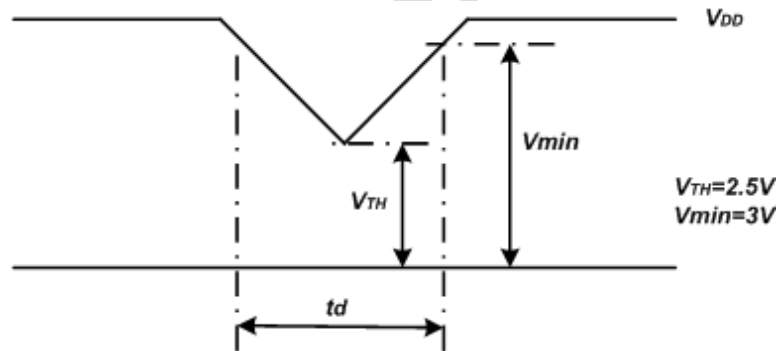

Note (3) Frame Rate=60Hz, VDD=3.3V, DC Current.

Note (4) Operating temperature 25°C, humidity 55%RH.

Note (5) The reference measurement circuit of rush current.

Document Title	M080AWT8 R1 Customer Approval Specification	Page No.	18/28
Document No.		Issue date	2016/01/07
		Revision	02

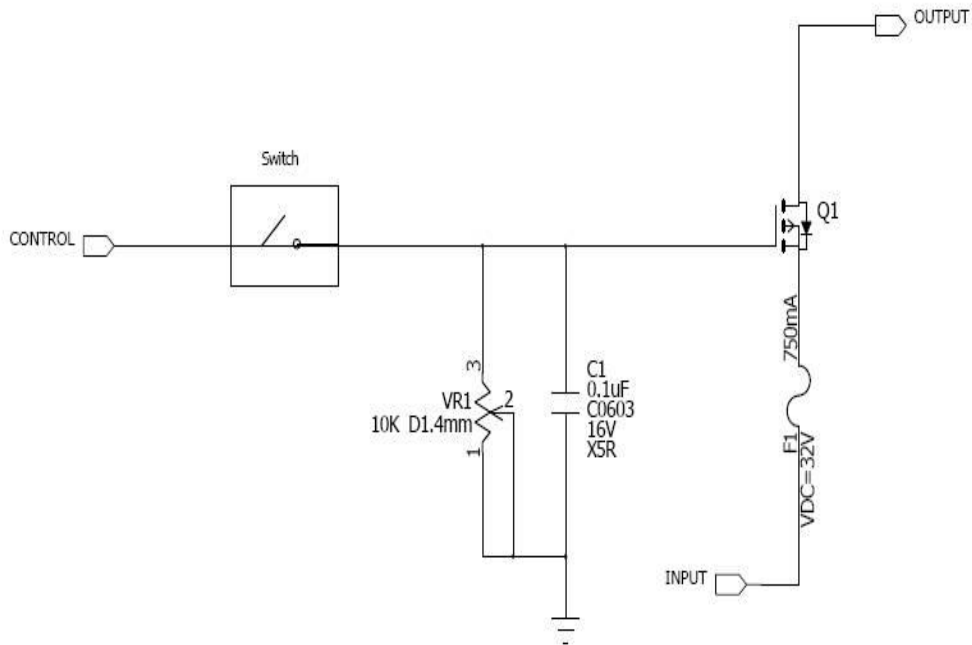

Note (6) Definition of V_{LED} and P_{LED}

$$V_{LED} = V_F \times 3, \quad P_{LED} = V_{LED} \times I_F \times 7$$

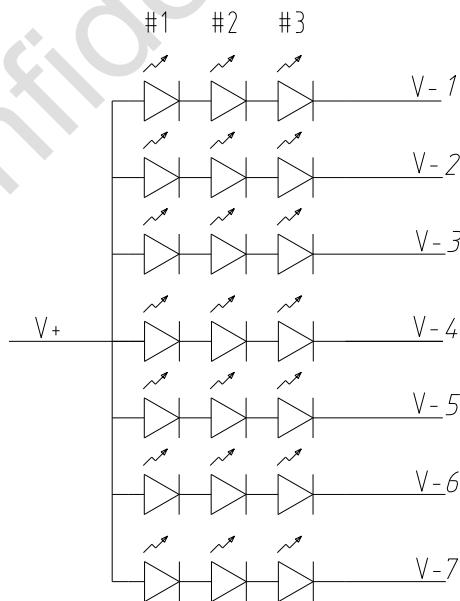

Note (7) The LED life time define as the estimated time to 50% degradation of initial luminous.

Document Title	M080AWT8 R1 Customer Approval Specification		Page No.	19/28	
Document No.		Issue date	2016/01/07	Revision	02

4.5 Power ON/OFF Sequence

Interface signals are also shown in the chart. Signals from any system shall be Hi- resistance state or low level when VDD voltage is off.

Figure 14 Power Sequence

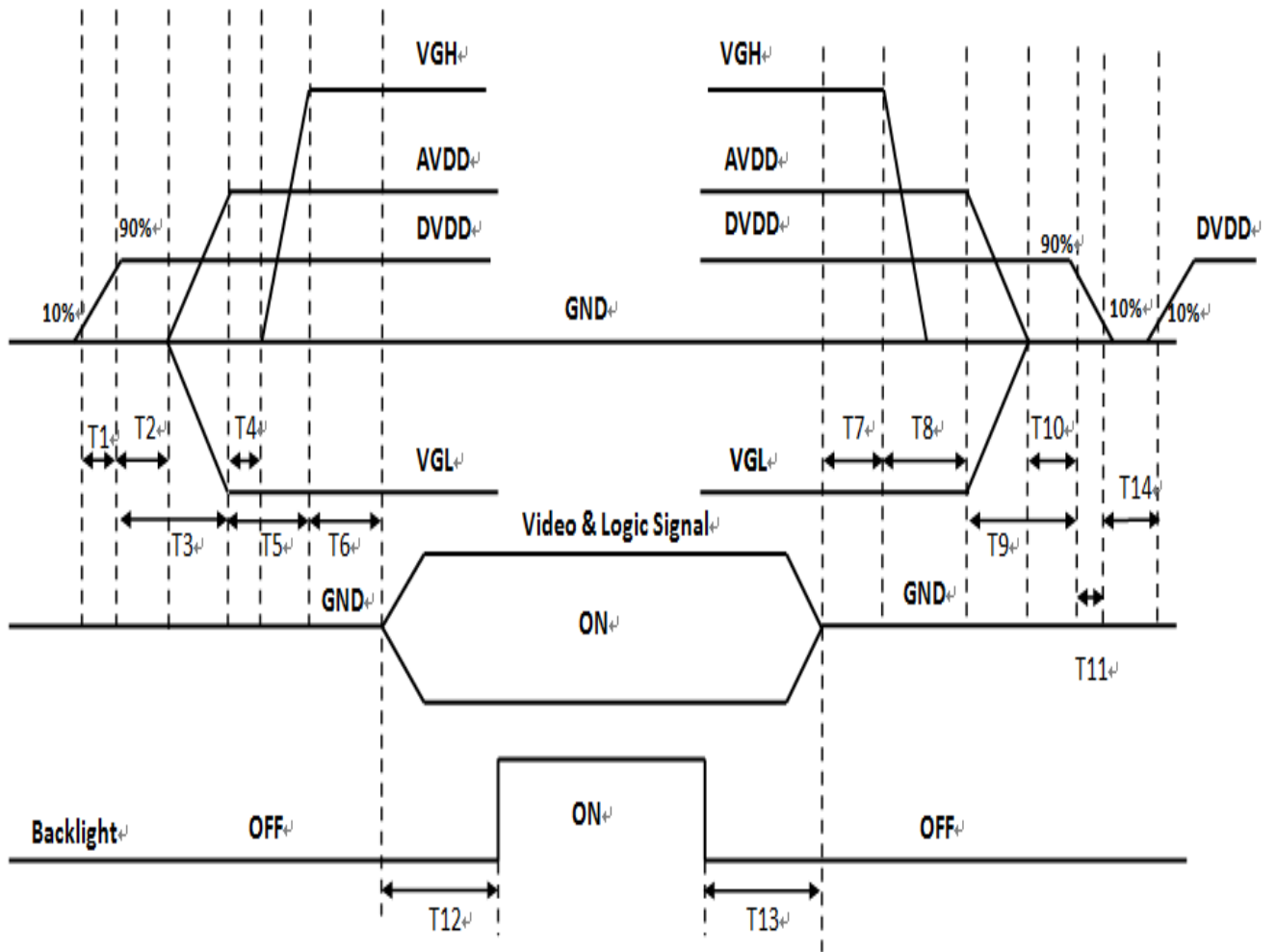

Power On: DVDD→AVDD/VGL→VGH→Video & Logic Signal→Backlight

Power Off: Backlight→ Video & Logic Signal→ VGH→ AVDD/VGL→ DVDD

Document Title	M080AWT8 R1 Customer Approval Specification		Page No.	20/28	
Document No.		Issue date	2016/01/07	Revision	02

Table 10 Power Sequencing Requirements

Parameter	Symbol	Min.	Typ.	Max.	Unit
DVDD Rising Time from 10% to 90%	T1	0.5	-	10	ms
DVDD Good to AVDD/VGL On	T2	0	-	-	ms
DVDD Good to AVDD/VGL Good	T3	20	-	-	ms
AVDD/VGL Good to VGH On	T4	0	-	-	ms
AVDD/VGL Good to VGH Good	T5	10	-	-	ms
VGH Good to Signal Valid	T6	0	-	10	ms
Signal Disable to VGH Down	T7	0	-	50	ms
VGH Down to AVDD/VGL Down	T8	0	-	50	ms
AVDD/VGL Down to DVDD Down	T9	0	-	-	ms
AVDD/VGL Off to DVDD Down	T10	0	-	-	ms
DVDD Falling Time	T11	0	-	10	ms
Signal Valid to Backlight Power On	T12	200	-	-	ms
Backlight Power Off to Signal disable	T13	200	-	-	ms
Power Off Time	T14	500	-	-	ms

Document Title	M080AWT8 R1 Customer Approval Specification		Page No.	21/28	
Document No.		Issue date	2016/01/07	Revision	02

5.0 Mechanical Characteristics

5.1 Outline Drawing

Figure 15 Reference Outline Drawing (Front Side)

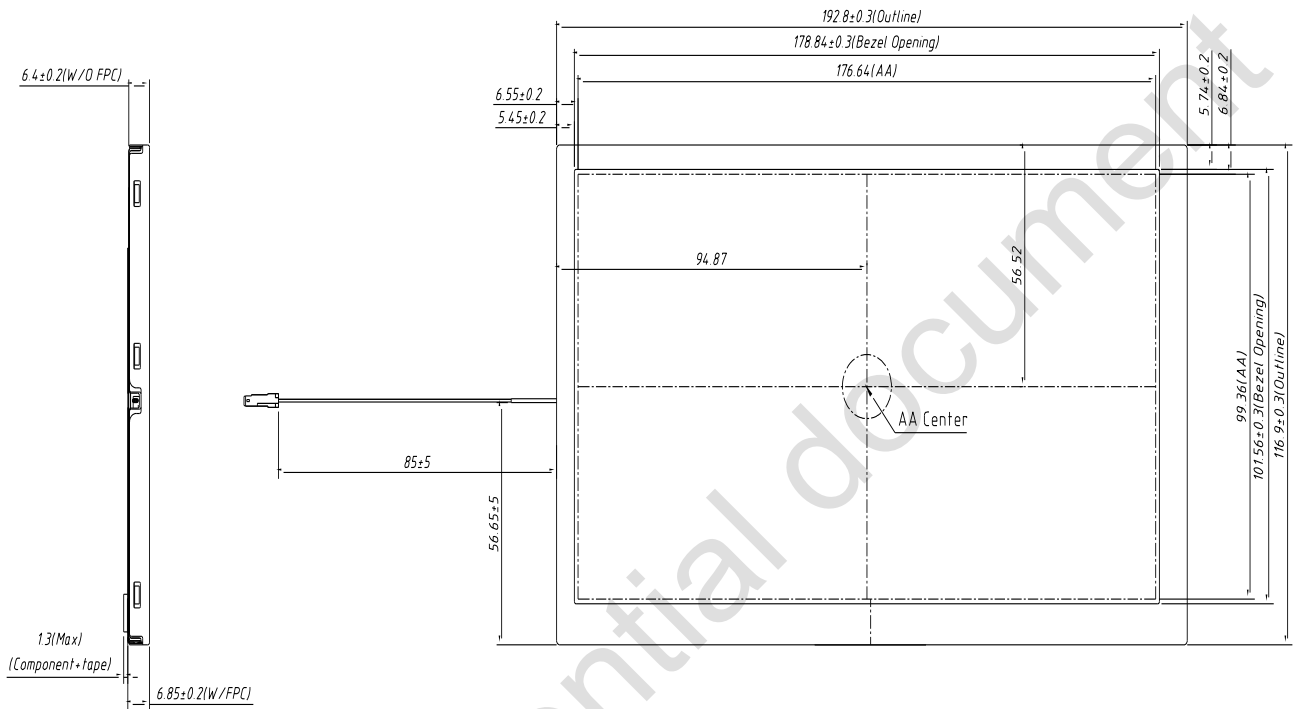

Note 1: Unnoted tolerance ± 0.3

Document Title	M080AWT8 R1 Customer Approval Specification	Page No.	22/28
Document No.		Issue date	2016/01/07
		Revision	02

Figure 16 Reference Outline Drawing (Back Side)

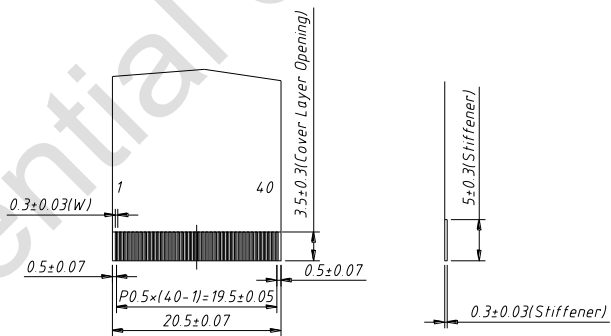
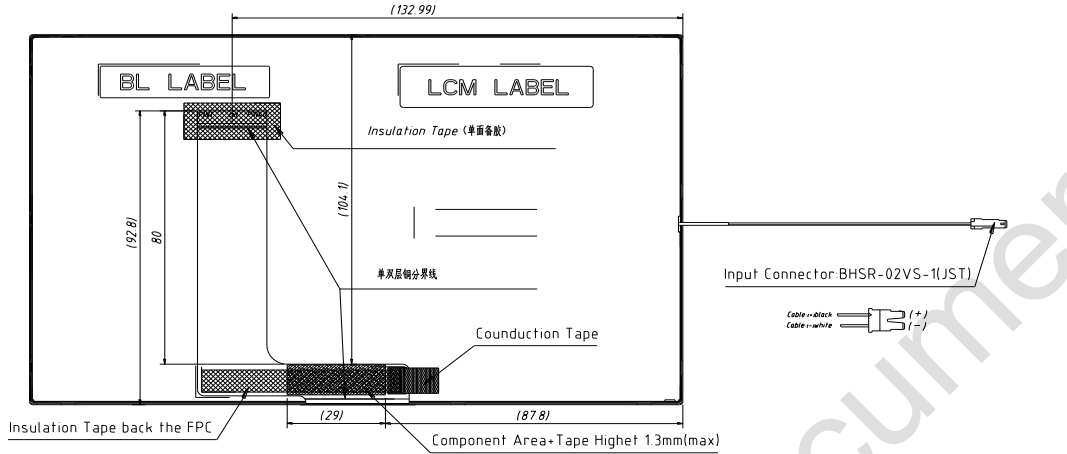

CN1 Detail

5.2 Dimension Specifications

Table 11 Module Dimension Specifications

Item	Min.	Typ.	Max.	Unit
Width	192.5	192.8	193.1	mm
Height	116.6	116.9	117.2	mm
Thickness	6.1	6.4	6.7	mm
Weight	-	-	240	g

Document Title	M080AWT8 R1 Customer Approval Specification	Page No.	23/28
Document No.		Issue date	2016/01/07
		Revision	02

Figure 17 BM Area

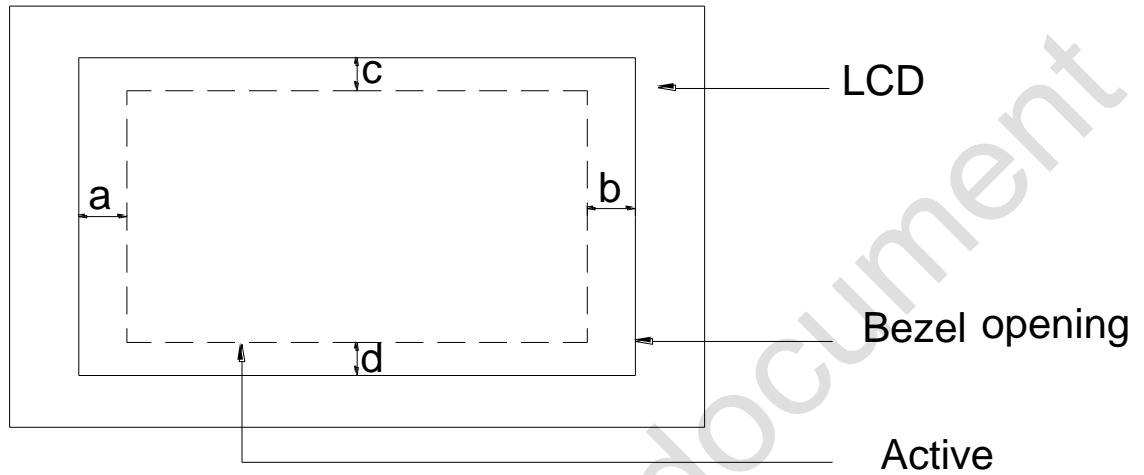

Note 1: $a=b=c=d, 1.1\text{mm}$

Document Title	M080AWT8 R1 Customer Approval Specification		Page No.	24/28	
Document No.		Issue date	2016/01/07	Revision	02

6.0 Reliability Conditions

Item	Package	Test Conditions	Note	
High Temperature Operating Test	Module	85°C, 500 hours	(1),(2),(3),(4)	
Low Temperature Operating Test	Module	-30°C, 500 hours	(1),(2),(3),(4)	
High Temperature Storage Test	Module	90°C, 500 hours	(1),(2),(4)	
Low Temperature Storage Test	Module	-40°C, 500 hours	(1),(2),(4)	
High Temperature/High Humidity Operating Test	Module	65°C, 90%RH, 500 hours	(1),(2),(3),(4)	
High Temperature/High Humidity Storage Test	Module	65°C, 90%RH, 500 hours	(1),(2),(3),(4)	
Thermal Shock Storage	Module	-40°(0.5hr)~85°(0.5hr)C/200cycles;	(1),(2),(3),(4), Meet the system reaches 615cycles	
ESD Test	Operating	Module	Contact	(5)
			Air	
			±8KV, 150pF(330 Ohm)(Class B)	
			±15KV, 150pF(330 Ohm)(ClassB)	

Note (1) All the judgments are under room temperature and the sample need to be static more than 2 hours in the room temperature before judge.

Note (2) During measurement, the condensation water or remains shall not be allowed.

Note (3) In operating test, the backlight voltage and current must be in specification.

Note (4) There is no display function issue occurred, all the cosmetic specification is judged before the reliability stress.

Note (5) In case of malfunction defect caused by ESD damage. If it would be recovered to normal state after placing for a while, it would be judge as pass.

Document Title	M080AWT8 R1 Customer Approval Specification	Page No.	25/28
Document No.		Issue date	2016/01/07
		Revision	02

7.0 Package Specification

Figure 18 Packing Method

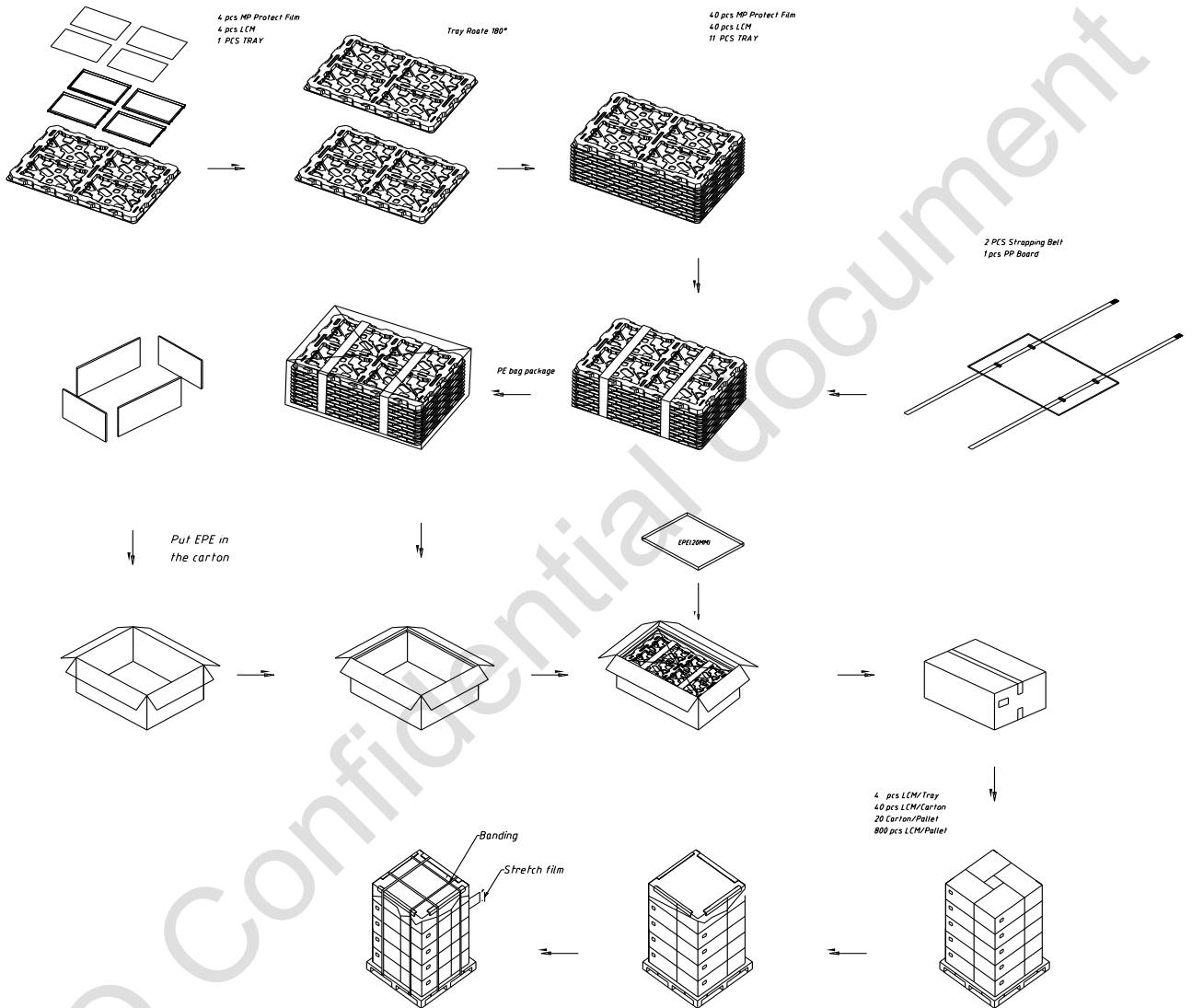

Document Title	M080AWT8 R1 Customer Approval Specification			Page No.	26/28
Document No.		Issue date	2016/01/07	Revision	02

8.0 Lot Mark



Note: This picture is only an example.

8.1 20 Lot Mark

1	2	3	4	5	6	7	8	9	10	11	12	13	14	15	16	17	18	19	20
---	---	---	---	---	---	---	---	---	----	----	----	----	----	----	----	----	----	----	----

Code 1,2,4,5,6,7,8,9,10,11,16: IVO internal flow control code.

Code 3: Production Location.

Code 12: Production Year.

Code 13: Production Month.

Code 14,15: Production Day.

Code 17,18,19,20: Serial Number.

8.2 23 Product Barcode

1	2	3	4	5	6	7	8	9	10	11	12	13	14	15	16	17	18	19	20	21	22	23
---	---	---	---	---	---	---	---	---	----	----	----	----	----	----	----	----	----	----	----	----	----	----

Code 1,2: Manufacture District.

Code 3,4,5,6,7: IVO internal module name.

Code 8,9,10,13,16: IVO internal flow control code.

Code 11,12: Cell location Suzhou, China defined as "KS".

Code 14,15: Module location Kunshan, China defined as "KS"; Yangzhou, China defined as "YZ"; Shenzhen, China defined as "SE"; Zhuhai, China defined as "ZH"; Suzhou, China defined as "SZ".

Code 17,18,19 : Year, Month, Day refer to Note(1), Note(2) and Note(3).

Note (1) Production Year

Year	2006	2007	2008	2009	2010	2011	2012	2013	2035
Mark	6	7	8	9	A	B	C	D	Z

Note (2) Production Month

Month	Jan.	Feb.	Mar.	Apr.	May.	Jun.	Jul.	Aug.	Sep.	Oct	Nov.	Dec.
Mark	1	2	3	4	5	6	7	8	9	A	B	C

Document Title	M080AWT8 R1 Customer Approval Specification		Page No.	27/28	
Document No.		Issue date	2016/01/07	Revision	02

Note (3) Production Day: 1~V.
Code 20~23 : Serial Number.

9.0 General Precaution

9.1 Use Restriction

This product is not authorized for use in life supporting systems, aircraft navigation control systems, military systems and any other application where performance failure could be life-threatening or otherwise catastrophic.

9.2 Handling Precaution

- (1) Please mount LCD module by using mounting holes arranged in four corners tightly.
- (2) Do not disassemble or modify the module. It may damage sensitive parts inside LCD module, and may cause scratches or dust on the display. IVO does not warrant the module, if customers disassemble or modify the module.
- (3) If LCD panel is broken and liquid crystal spills out, do not ingest or inhale liquid crystal, and do not contact liquid crystal with skin. If liquid crystal contacts mouth or eyes, rinse out with water immediately. If liquid crystal contacts skin or cloths, wash it off immediately with alcohol and rinse thoroughly with water.
- (4) Disconnect power supply before handling LCD module.
- (5) Refrain from strong mechanical shock and /or any force to the module.
- (6) Do not exceed the absolute maximum rating values, such as the supply voltage variation, input voltage variation, variation in parts parameters, environmental temperature; etc otherwise LCD module may be damaged. It's recommended employing protection circuit for power supply.
- (7) Do not touch, push or rub the polarizer with anything harder than HB pencil lead. Use fingerstalls of soft gloves in order to keep clean display quality, when persons handle the LCD module for incoming inspection or assembly.
- (8) When the surface is dusty, please wipe gently with absorbent cotton or other soft material. When cleaning the adhesives, please use absorbent cotton wetted with a little petroleum benzene or other adequate solvent.
- (9) Wipe off saliva or water drops as soon as possible. If saliva or water drops contact with polarizer for a long time, they may causes deformation or color fading.
- (10) Protection film must remove very slowly from the surface of LCD module to prevent from electrostatic occurrence.
- (11) Because LCD module uses CMOS-IC on circuit board and TFT-LCD panel, it is very weak to electrostatic discharge, please be careful with electrostatic discharge. Persons who handle the module should be grounded through adequate methods.
- (12) Do not adjust the variable resistor located on the module.

9.3 Storage Precaution

- (1) Please do not leave LCD module in the environment of high humidity and high temperature for a long time.
- (2) The module shall not be exposed under strong light such as direct sunlight. Otherwise, display characteristics may be changed.
- (3) The module should be stored in a dark place. It is prohibited to apply sunlight or fluorescent light in storage.

9.4 Operation Precaution

- (1) Do not connect or disconnect the module in the "Power On" condition.

Document Title	M080AWT8 R1 Customer Approval Specification		Page No.	28/28	
Document No.		Issue date	2016/01/07	Revision	02

- (2) Power supply should always be turned on/off by "Power On/Off Sequence".
- (3) Module has high frequency circuits. Sufficient suppression to the electromagnetic interference should be done by system manufacturers. Grounding and shielding methods may be important to minimize the interference.
- (4) After installation of the TFT module into an enclosure, do not twist nor bend the TFT module even momentary. At designing the enclosure, it should be taken into consideration that no bending/twisting forces are applied to the TFT module from outside. Otherwise the TFT module may be damaged.

9.5 Others

- (1) Ultra-violet ray filter is necessary for outdoor operation.
- (2) Avoid condensation of water which may result in improper operation or disconnection of electrode.
- (3) If the module keeps displaying the same pattern for a long period of time, the image may be "sticked" to the screen.
- (4) This module has its circuitry PCB's on the rear side and should be handled carefully in order not to be stressed.

9.6 Disposal

When disposing LCD module, obey the local environmental regulations.