



Document Title	M101NWT2 R1 product information			Page No.	1/30
Document No.		Issue Date	2011/11/16	Revision	06

Product Information

To:

Product Name: M101NWT2 R1

Document Issue Date:2011/11/16

www.yslcd.com.tw

- Note: 1. Please contact InfoVision Company. before designing your product based on this product.
2. The information contained herein is presented merely to indicate the characteristics and performance of our products. No responsibility is assumed by IVO for any intellectual property claims or other problems that may result from application based on the module described herein.

FQ-7-30-0-009-02C



Document Title	M101NWT2 R1 product information			Page No.	2/30
Document No.		Issue Date	2011/11/16	Revision	06

Revision	Date	Page	Old Description	New Description	Remark
00	2010/04/06	--	--	first issued	
01	2010/04/07	4	Response time :16ms(typ)	Response time : 8ms(typ)	
02	2010/04/08	16	TBD	Update Rx/y, Gx/y, Bx/y	
		8		Add LED power consumption define	
		10		modify connector type	
		9		Add VDD Rise time measure condition	
03	2010/04/09	15	T13 min value is 1000ms	Modify T13 min value is 500ms	
		19		Update front side outline drawing	
		20		Update back side outline drawing	
		22	TBD	Update package specification	
04	2010/04/12	26	TBD	Add EDID table	
05	2010/04/30	8	V_LED_EN: High 2.6V(min)	Modify to 2.0V(min)	
		11	Vcom: 1.0(min),1.2(typ),1.4(max)	Modify Vcom define	
06	2011/11/16	17		Update Figure 11 Measurement setup	



Document Title	M101NWT2 R1 product information			Page No.	3/30
Document No.		Issue Date	2011/11/16	Revision	06

Contents

1. GENERAL DESCRIPTIONS.....	4
2. ABSOLUTE MAXIMUM RATINGS	7
3. ELECTRICAL SPECIFICATION	8
4. OPTICAL CHARACTERISTICS.....	16
5. MECHANICAL CHARACTERISTICS.....	19
6. PACKAGE SPECIFICATION	22
7. LOT MARK.....	23
8. GENERAL PRECAUTION.....	24
9. EDID DATA STRUCTURE.....	26

www.yslcd.com.tw

Document Title	M101NWT2 R1 product information			Page No.	4/30
Document No.		Issue Date	2011/11/16	Revision	06

1 General Descriptions

1.1 Introduction

The M101NWT2 R1 is a Color Active Matrix Thin Film Transistor (TFT) Liquid Crystal Display (LCD) module, which uses amorphous Silicon TFT as a switching device. It is composed of a TFT LCD panel, a timing controller, voltage reference, common voltage, column driver, and row driver circuit. This TFT LCD has a 10.1-inch (diagonally measured) active display area with WSVGA resolution (1,024 horizontal by 600 vertical pixel array).

1.2 Features

- 10.1" TFT LCD Panel
- LED Light-bar Backlight System
- Supports WSVGA (H:1,024 lines, V:600 pixels) Resolution
- Compatible with RoHS Standard

1.3 Product Summary

Items	Specifications	Unit	Remark
Screen Diagonal	10.1	inch	
Active Area	222.72(H) x 125.28(V)	mm	
Pixels(H x V)	1,024 (x3) x 600	-	
Pixel Pitch	0.2175(H) x 0.2088(V)	mm	
Pixel Arrangement	R.G.B. Vertical Stripe	-	
Display Mode	TN Mode, Normally White	-	
White Luminance	200 (Typ.)	cd/ m ²	5 Points Average, 20mA per LED
Contrast Ratio	500 (Typ.)	-	
Response Time	8 (Typ.)	ms	
View Angle(L/R/U/D)	45/45/15/35 (Typ.)	-	
Input Voltage	+3.3 (Typ.)	V	
Power Consumption	2.4	Watt	Black Pattern
Module Weight	190 (Max.)	g	
Outline Dimension(H x V x D)	235.5(H) x 143.5(V) x 5.2(D) (Max.)	mm	
Electrical Interface (Logic)	LVDS	-	
Support Color	262 K	-	
NTSC	45 (Typ.)	%	
Optimum Viewing Direction	6 o'clock	-	
Surface Treatment	Glare + HC	-	

Document Title	M101NWT2 R1 product information			Page No.	5/30
Document No.		Issue Date	2011/11/16	Revision	06

1.4 Functional Block Diagram

Figure 1 shows the functional block diagram of the LCD module.

Figure 1 Block Diagram

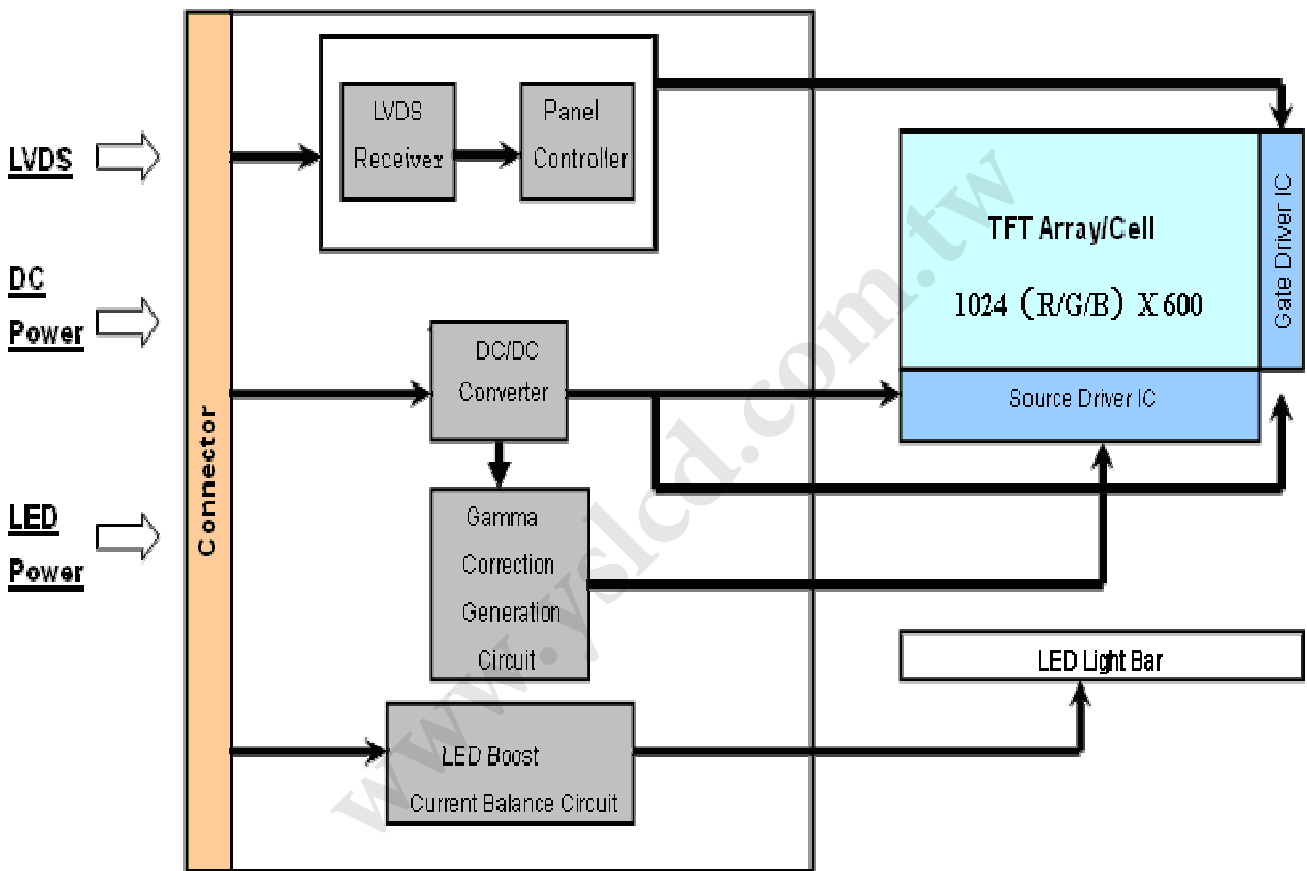

Document Title	M101NWT2 R1 product information			Page No.	6/30
Document No.		Issue Date	2011/11/16	Revision	06

1.5 Pixel Format Image

Figure 2 shows the relationship of the input signals and LCD pixel format image.

Figure 2 Pixel Format

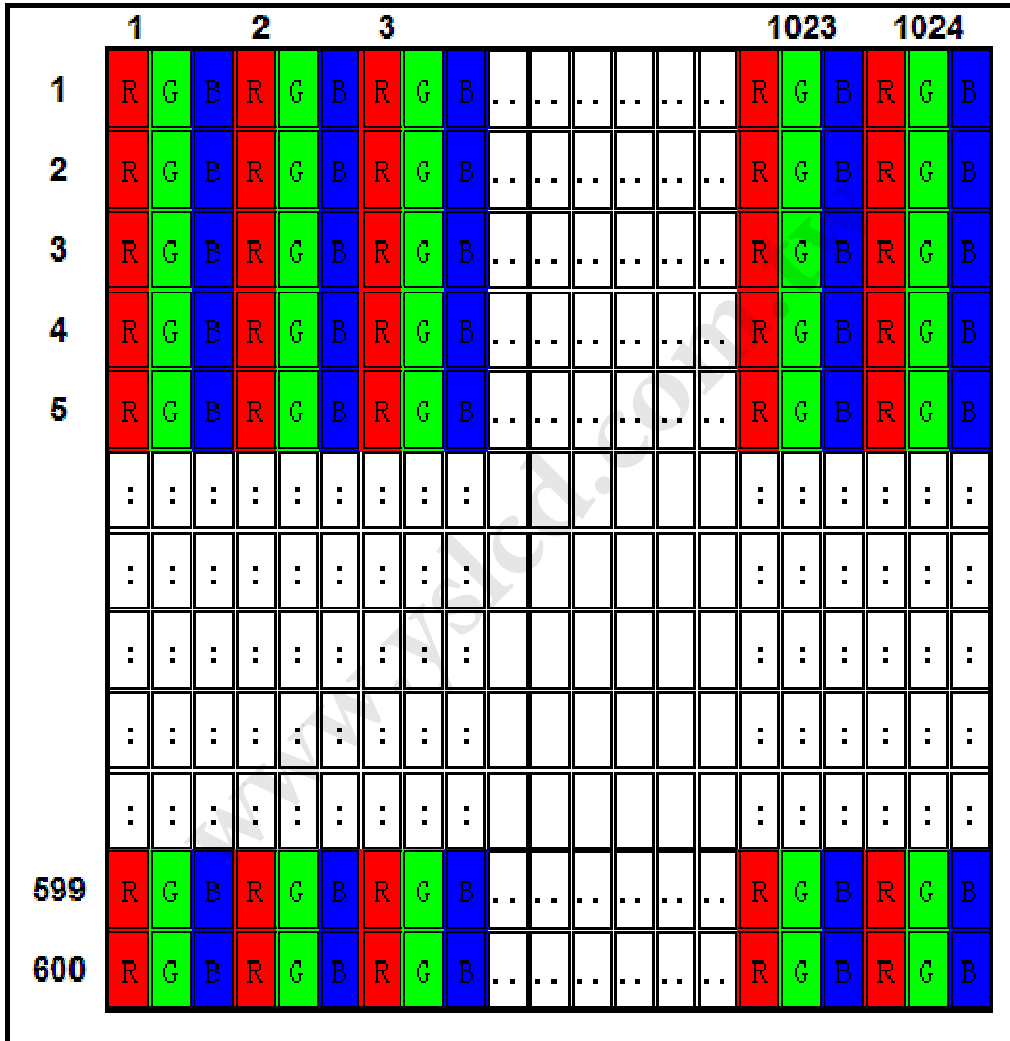

Document Title	M101NWT2 R1 product information			Page No.	7/30
Document No.		Issue Date	2011/11/16	Revision	06

2 Absolute Maximum Ratings

The followings are maximum values which, if exceeded, may cause faulty operation or damage to the LCD module.

Table 1

Item	Symbol	Min.	Max.	Unit	Conditions
Supply Voltage	V _{DD}	-0.3	4.0	V	-
Supply V _{LED} Voltage	V _{LED}	5	21	V	-
Input Signal	-	-0.3	2.7	V	LVDS Signals
Operating Temperature	TOP	0	50	°C	Note(3)
Operating Humidity	HOP	10	80	%RH	Note(3)
Storage Temperature	TST	-20	60	°C	Note(3)
Storage Humidity	HST	10	90	%RH	Note(3)
Vibration	Level	-	1.5	G	30min. for X, Y, Z axis
	Bandwidth	-	10~500Hz	Hz	
Shock	Level	-	220	G	Half Sine Waveform, 2ms
LED Current	I _{LED}	-	20.5	mA	Per LED

Note

- (1)Maximum Wet-Bulb should be 39°C and No condensation.
- (2)When you apply the LCD module for OA system, please make sure to keep the temperature of LCD module under 60°C.
- (3)Storage /Operating temperature & humidity:

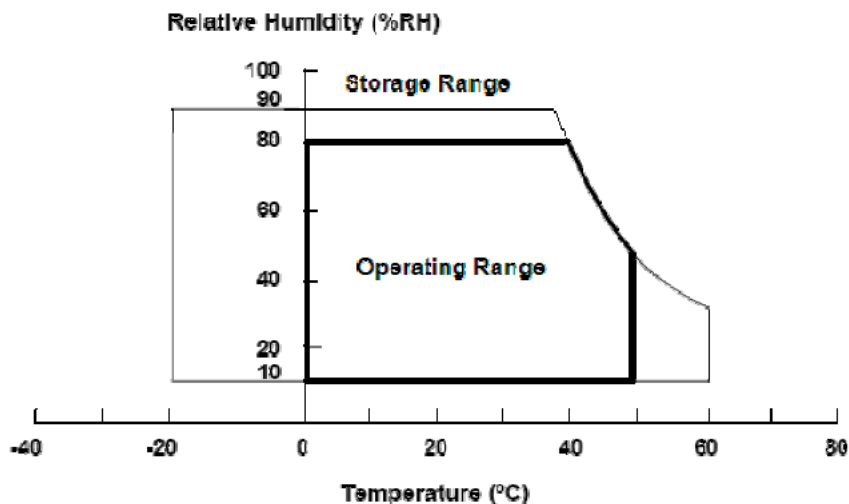

Document Title	M101NWT2 R1 product information			Page No.	8/30
Document No.		Issue Date	2011/11/16	Revision	06

3 Electrical Specification

3.1 Electrical Characteristics

Table 2 Electrical Characteristics

Symbol	Parameter	Min.	Typ.	Max.	Units	Condition	
V _{DD}	Logic/LCD Drive Voltage	3	3.3	3.6	V	Note (1)	
I _{DD}	VDD Current	-	160	-	mA	Black Pattern, 60Hz	
P _{DD}	VDD Power	-	-	0.53	W	Black Pattern, 60Hz	
I _{rush}	Rush Current	-	-	2	A	Note (2)	
V _{DDrp}	Allowable Logic/LCD Drive Ripple Voltage	-	-	300	mVp-p	-	
V _{LED}	LED Input	5	12	21	V	-	
V _F	LED Forward Voltage	2.95	3.3	3.4	V	-	
I _F	LED Forward Current	19.5	20	20.5	mA	-	
P _{LED}	LED Power Consumption	-	-	1.87	W	Note(3)	
L _T	LED Life Time	10,000	-	-	Hours	Note(4)	
V _{PWM_EN}	PWM Signal Voltage	High	2	3.3	3.6	V	-
		Low	0	-	0.5	V	
F _{PWM}	Output PWM Frequency	-	200	1K	Hz	-	
V _{LED_EN}	LED Enable Voltage	High	2	3.3	3.6	V	-
		Low	0	-	0.5	V	
PWM	PWM Duty Ratio	5	-	100	%	-	

Note: (1)V_{DD} Power Dip Condition

Figure 3 V_{DD} Power Dip

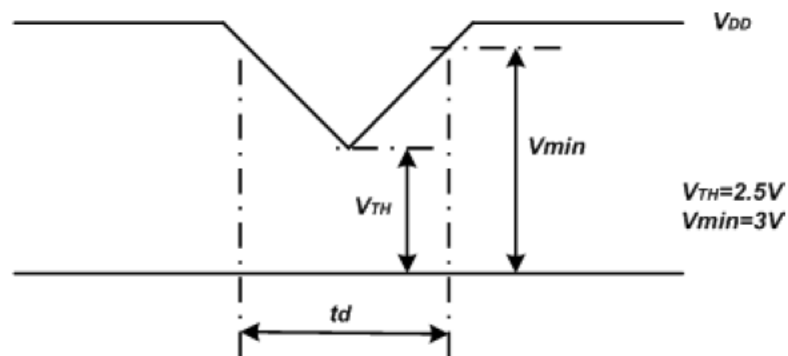

If $V_{TH} < V_{DD} \leq V_{min}$ and $t_d \leq 10ms$, our panel must revive automatically when the voltage returns to normal.

Document Title	M101NWT2 R1 product information			Page No.	9/30
Document No.		Issue Date	2011/11/16	Revision	06

(2)Measure Condition

Figure 4 V_{DD} rising time

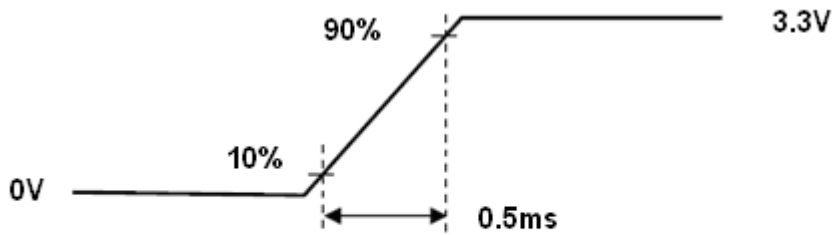

VDD rising time

- (3) P_{LED} is calculation value for reference. $P_{LED} = 24 \times V_F$ (Normal Distribution) $\times I_F$ (Normal Distribution) / Efficiency
- (4) The lifetime of LED is defined as the time when LED packages continue to operate under the conditions at $T_a = 25^\circ C$ and $I_F = 20$ mA (per chip) until the brightness becomes $\leq 50\%$ of its original value.
- (5) All values are measured at condition of $V_{LED} = 12V$ and $T_a = 25^\circ C$.

Document Title	M101NWT2 R1 product information			Page No.	10/30
Document No.		Issue Date	2011/11/16	Revision	06

3.2 Interface Connector

Table 3 Connector Name / Designation

Manufacturer	Starconn/I-PEX (or equivalent)
Type / Part Number	111A40-O000RA-G3(Starconn)
Mating Receptacle/Part Number	20453-040T(I-PEX)

Table 4 Signal Pin Assignment

Pin #	Signal Name	Description	Remarks
1	GND	Ground	
2	V _{DD}	Power Supply 3.3V (Typ.)	
3	V _{DD}	Power Supply 3.3V (Typ.)	
4	V _{ED D}	EDID +3.3V Power	
5	NC	Not Connected(Reserve)	LCD panel self test enable
6	CLK _{EDID}	EDID Clock Input	
7	DAT _{ED D}	EDID Data Input	
8	RXin0-	- LVDS Differential Data Input(R0-R5,G0)	
9	RXin0+	+ LVDS Differential Data Input(R0-R5,G0)	
10	GND	Ground	
11	RXin1-	- LVDS Differential Data Input(G1-G5,B0-B1)	
12	RXin1+	+ LVDS Differential Data Input(G1-G5,B0-B1)	
13	GND	Ground	
14	RXin2-	- LVDS Differential Data Input(B2-B5,HS,VS,DE)	
15	RXin2+	+ LVDS Differential Data Input(B2-B5,HS,VS,DE)	
16	GND	Ground	
17	CLKN-	- LVDS Differential Clock Input	
18	CLKN+	+ LVDS Differential Clock Input	
19	NC	Not Connected(Reserve)	
20	NC	Not Connected(Reserve)	
21	NC	Not Connected(Reserve)	
22	GND	Ground-Shield	
23	NC	Not Connected(Reserve)	
24	NC	Not Connected(Reserve)	
25	GND	Ground-Shield	
26	NC	Not Connected(Reserve)	
27	NC	Not Connected(Reserve)	
28	GND	Ground-Shield	

Document Title	M101NWT2 R1 product information			Page No.	11/30
Document No.		Issue Date	2011/11/16	Revision	06

29	NC	Not Connected(Reserve)	
30	NC	Not Connected(Reserve)	
31	V_LED_GND	LED Ground	
32	V_LED_GND	LED Ground	
33	V_LED_GND	LED Ground	
34	NC	Not Connected(Reserve)	
35	V_PWM_EN	System PWM Logic Input Level	
36	V_LED_EN	LED Enable Input Level(+3.3V)	
37	NC	Not Connected(Reserve)	
38	V_LED	LED Power Supply 5-21V	
39	V_LED	LED Power Supply 5-21V	
40	V_LED	LED Power Supply 5-21V	

Note: All input signals shall be at low or Hi-Z state when V_{DD} is off.

3.3 LVDS Receiver

3.3.1 Signal Electrical Characteristics For LVDS Receiver

The built-in LVDS receiver is compatible with (ANSI/TIA/TIA-644) standard.

Table 5 LVDS Receiver Electrical Characteristics

Parameter	Symbol	Min.	Typ.	Max.	Unit	Conditions
Differential Input High Threshold	V _{th}	-	-	+100	mV	V _{cm} =+1.2V
Differential Input Low Threshold	V _{tl}	-100	-	-	mV	V _{cm} =+1.2V
Magnitude Differential Input Voltage	V _{id}	100	-	600	mV	
Common Mode Voltage	V _{cm}	V _{id} /2 +0.6	1.2	1.8- V _{id} /2	V	
Common Mode Voltage Offset	ΔV _{cm}	-	-	50	mV	V _{cm} =+1.2V

Note:

- (1)Input signals shall be at low or Hi-Z state when V_{DD} is off.
- (2)All electrical characteristics for LVDS signal are defined and shall be measured at the interface connector of LCD.
- (3)All values are measured at condition of V_{DD} =3.3V and Ta=25°C .

Document Title	M101NWT2 R1 product information			Page No.	12/30
Document No.		Issue Date	2011/11/16	Revision	06

Figure 5 Voltage Definitions

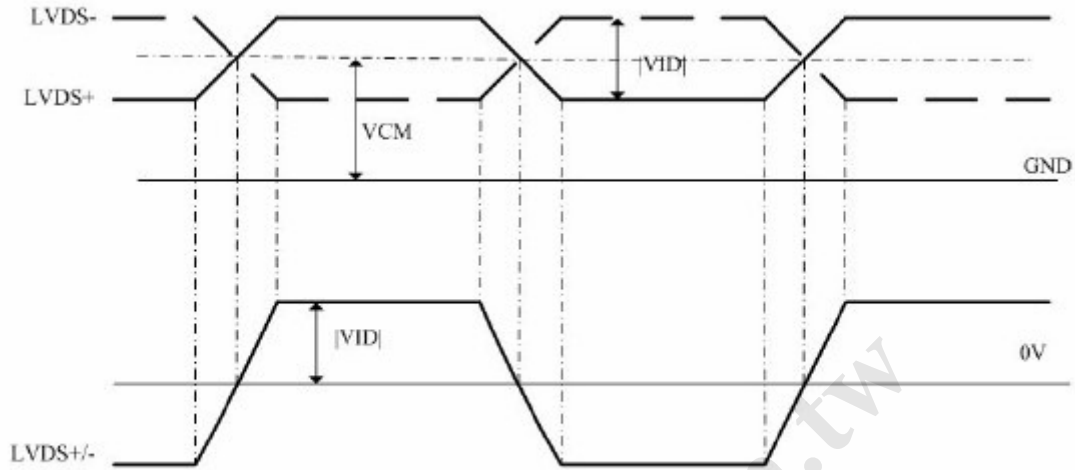
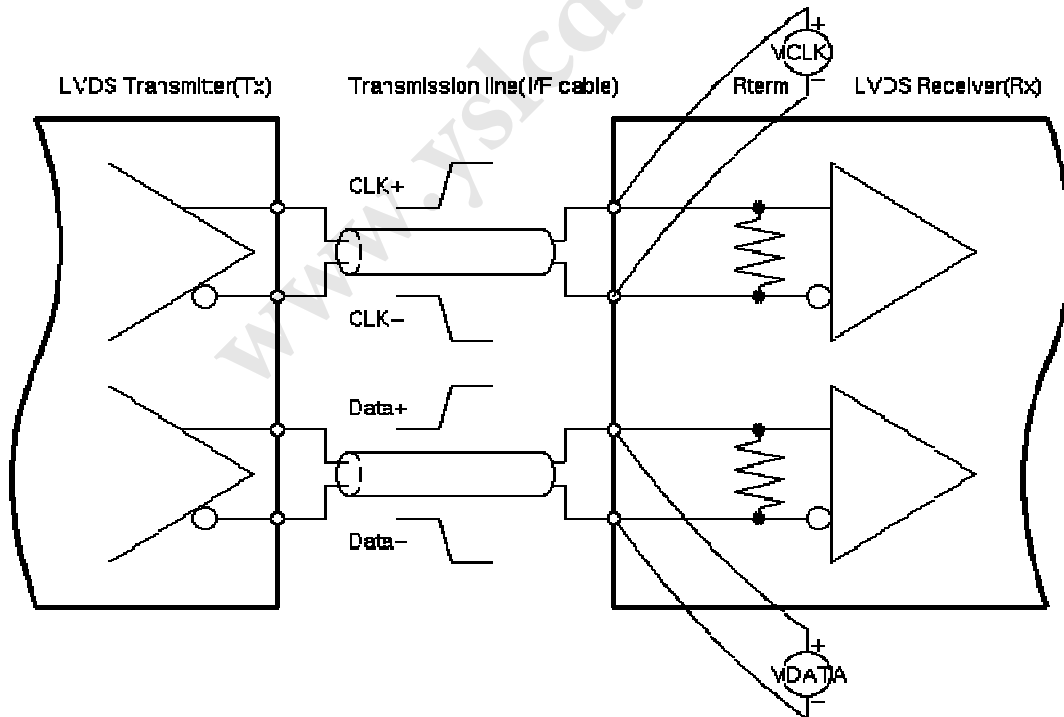
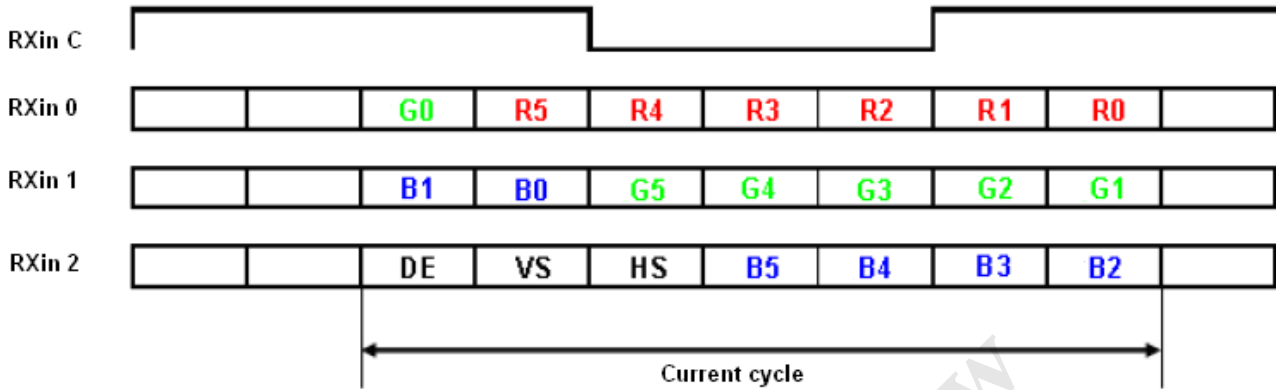

Figure 6 Measurement System



Document Title	M101NWT2 R1 product information			Page No.	13/30
Document No.		Issue Date	2011/11/16	Revision	06

Figure 7 Data mapping



3.3.2 LVDS Receiver Internal Circuit

Figure 8 LVDS Receiver Internal Circuit shows the internal block diagram of the LVDS receiver. This LCD module equips termination resistors for LVDS link.

Figure 8 LVDS Receiver Internal Circuit

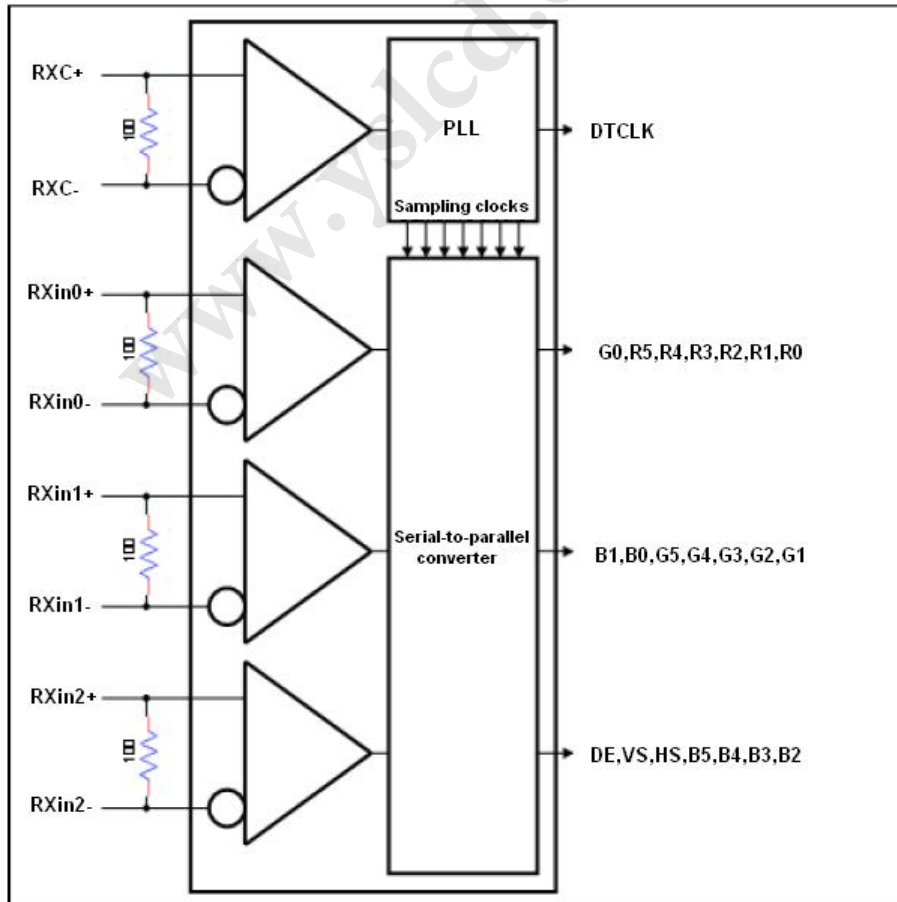

Document Title	M101NWT2 R1 product information			Page No.	14/30
Document No.		Issue Date	2011/11/16	Revision	06

3.4 Interface Timings

Table 6 Interface Timings

Parameter	Symbol	Unit	Min.	Typ.	Max.
LVDS Clock Frequency(single)	F_{dck}	MHz	44.4	50.4	65.2
H Total Time	H_{total}	Clocks	1,320	1,344	1,362
H Active Time	H_{ac}	Clocks	1,024	1,024	1,024
V Total Time	V_{total}	Lines	612	625	638
V Active Time	V_{ac}	Lines	600	600	600
Frame Rate	V_{sync}	Hz	55	60	65

Figure 9 Timing Characteristics

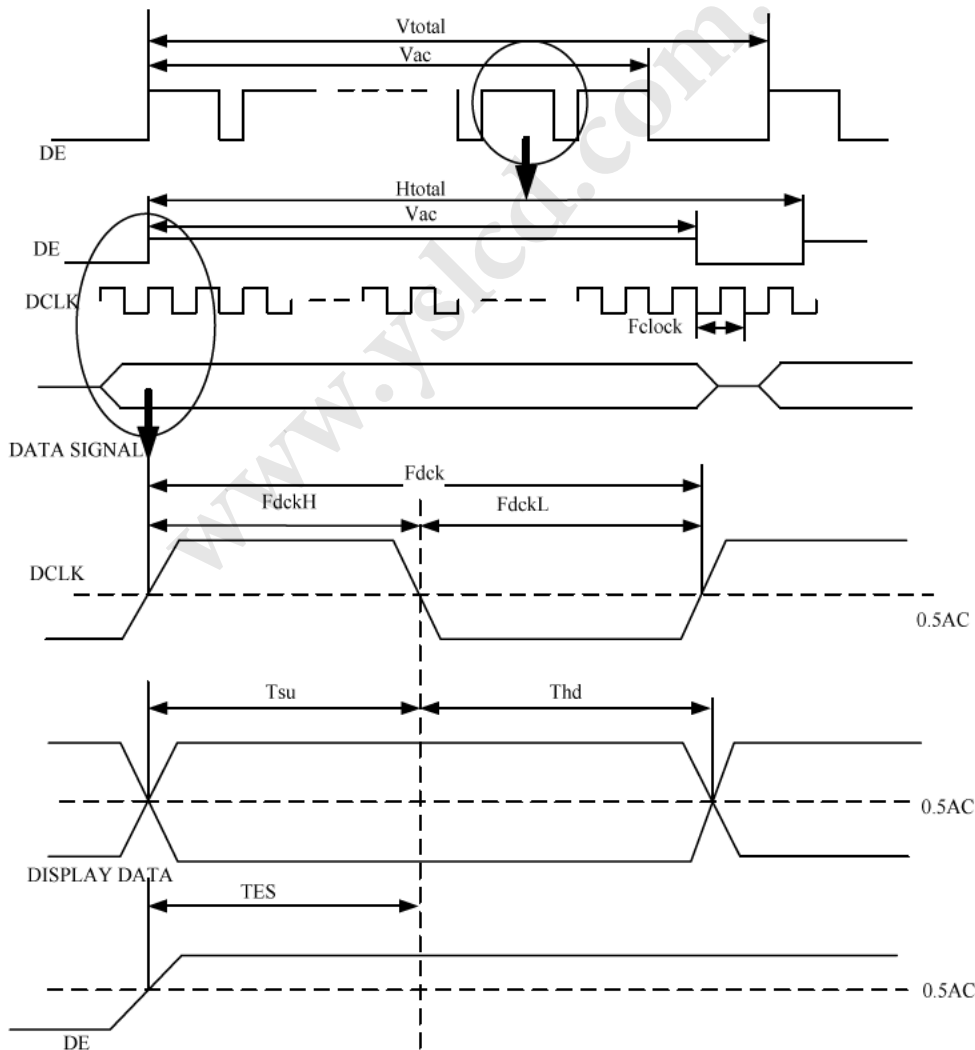

Note: TES is data enable signal setup time.

Document Title	M101NWT2 R1 product information			Page No.	15/30
Document No.		Issue Date	2011/11/16	Revision	06

3.5 Power ON/OFF Sequence

V_{DD} power, interface signals, and lamp on/off sequence are showing on Figure 10.

Signals shall be Hi-Z state or low level when V_{DD} is off.

Figure 10

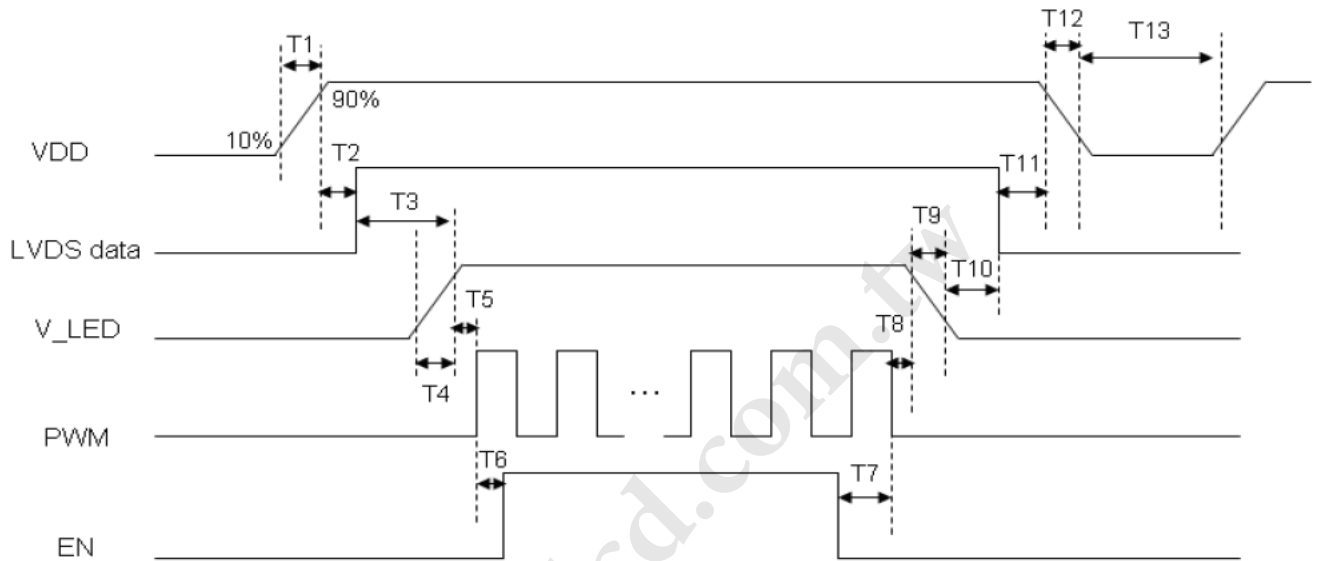

Table 7 Power Sequencing Requirements

Parameter	Symbol	Min.	Typ.	Max.	Unit
V_{DD} Rising Time	T1	0.5	-	10	ms
V_{DD} Good to Signal Valid	T2	30	-	90	ms
Signal Valid to Backlight on	T3	200	-	-	ms
Backlight Power on Time	T4	0.5	-	-	ms
Backlight V_{DD} Good to System PWM on	T5	10	-	-	ms
System PWM on to Backlight Enable on	T6	10	-	-	ms
Backlight Enable off to System PWM off	T7	0	-	-	ms
System PWM off to B/L Power Disable	T8	10	-	-	ms
Backlight Power off Time	T9	-	10	30	ms
Backlight off to Signal Disable	T10	200	-	-	ms
Signal Disable to Power Down	T11	0	-	50	ms
V_{DD} Falling Time	T12	-	10	30	ms
Power off	T13	500	-	-	ms

Document Title	M101NWT2 R1 product information			Page No.	16/30
Document No.		Issue Date	2011/11/16	Revision	06

4 Optical Characteristics

The optical characteristics are measured under stable conditions as following notes.

Table 8 Optical Characteristics

Item	Conditions		Specification				Note		
			Min.	Typ.	Max.	Unit			
Viewing Angle [degrees] K=Contrast Ratio>10	Horizontal	Left	40	45	-	Deg.	(1),(2)		
		Right	40	45	-	Deg.			
	Vertical	Up	10	15	-	Deg.			
		Down	30	35	-	Deg.			
Contrast Ratio	Center		400	500	-	-	(1),(3)		
Response Time	Rising		-	3	-	ms			
	Falling		-	5	-	ms			
	Rising + Falling		-	8	16	ms	(1),(4)		
Color Chromaticity (CIE1931)	Red	x	Typ. -0.03	0.579	Typ. +0.03	-	(1)		
	Red	y		0.346		-	(1)		
	Green	x		0.336		-	(1)		
	Green	y		0.560		-	(1)		
	Blue	x		0.156		-	(1)		
	Blue	y		0.123		-	(1)		
	White	x		0.283		0.313	0.343	-	(1)
	White	y		0.299		0.329	0.359	-	(1)
White Luminance [cd/m ²]	I _{LED} =20.0mA		180	200	-	cd/m ²	(1), (5)		
Luminance Uniformity [%]	I _{LED} =20mA, 13points		62.5	-	-	-	(1), (6)		
	I _{LED} =20mA, 5points		80.0	-	-	-			

Note: (1)Measurement Setup

The LCD module should be stabilized at 25°C for 15 minutes to avoid abrupt temperature change during measuring. In order to stabilize the luminance, the measurement should be executed after lighting backlight for 15 minutes in a windless room.

Document Title	M101NWT2 R1 product information			Page No.	17/30
Document No.		Issue Date	2011/11/16	Revision	06

Figure 11 Measurement Setup

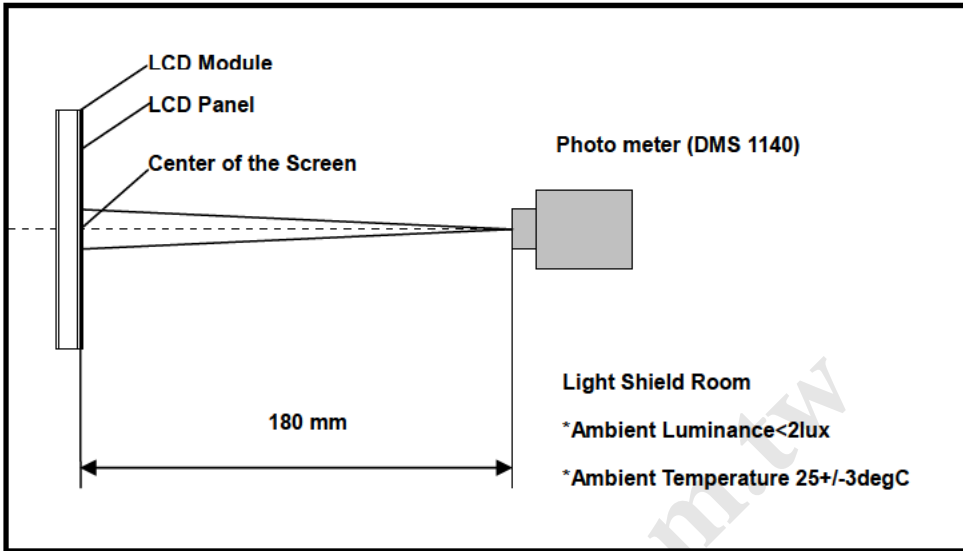

(2) Definition of Viewing Angle

Figure 12 Definition of Viewing Angle

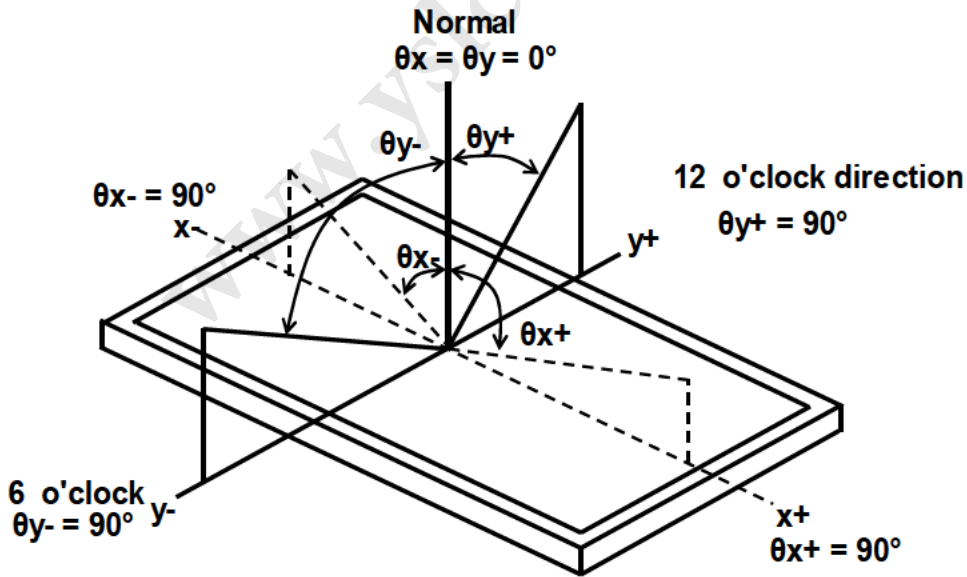

(3) Definition of Contrast Ratio (CR)

The contrast ratio can be calculated by the following expression

$$\text{Contrast Ratio (CR)} = L_{63} / L_0$$

L63: Luminance of gray level 63, L0: Luminance of gray level 0

(4) Definition of Response Time (T_R , T_F)

Document Title	M101NWT2 R1 product information			Page No.	18/30
Document No.		Issue Date	2011/11/16	Revision	06

Figure 13 Definition of Response Time

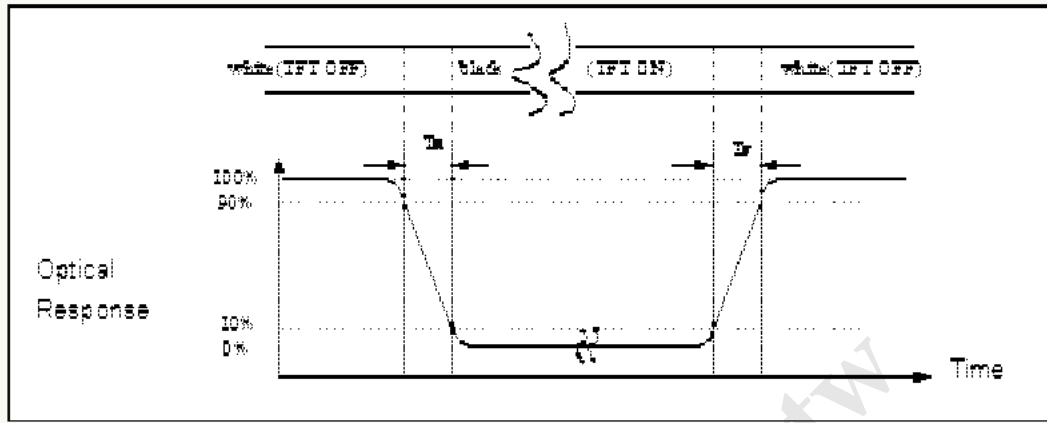

(5) Definition of Luminance White

Measure the luminance of gray level 63 at 5 points (Fig. 14).

Center of Luminance = Y1

$$\text{Average Luminance of 5 points} = \frac{Y_1 + Y_2 + Y_3 + Y_4 + Y_5}{5}$$

(6) Definition of Luminance Uniformity (Variation)

Measure the luminance of gray level 63 at 13 points.

$$\text{Uniformity of 13 points} = \frac{\text{Min Luminance of } Y_1 \sim Y_{13}}{\text{Max Luminance of } Y_1 \sim Y_{13}} \times 100\%$$

$$\text{Uniformity of 5 points} = \frac{\text{Min Luminance of } Y_1 \sim Y_5}{\text{Max Luminance of } Y_1 \sim Y_5} \times 100\%$$

Figure 14 Measurement Locations of 13 Points

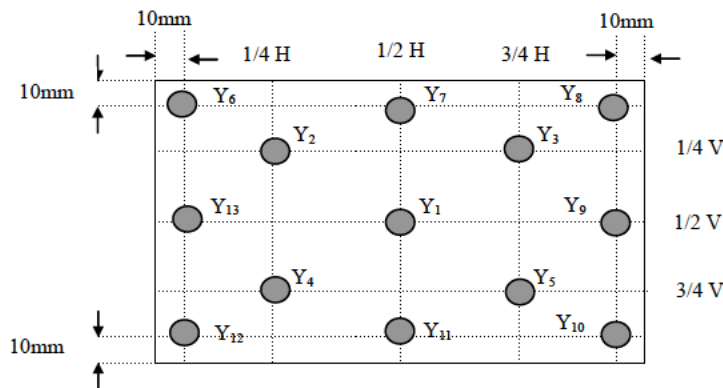

Document Title	M101NWT2 R1 product information			Page No.	19/30
Document No.		Issue Date	2011/11/16	Revision	06

5 Mechanical Characteristics

Figure 15 Reference Outline Drawing (Front Side)

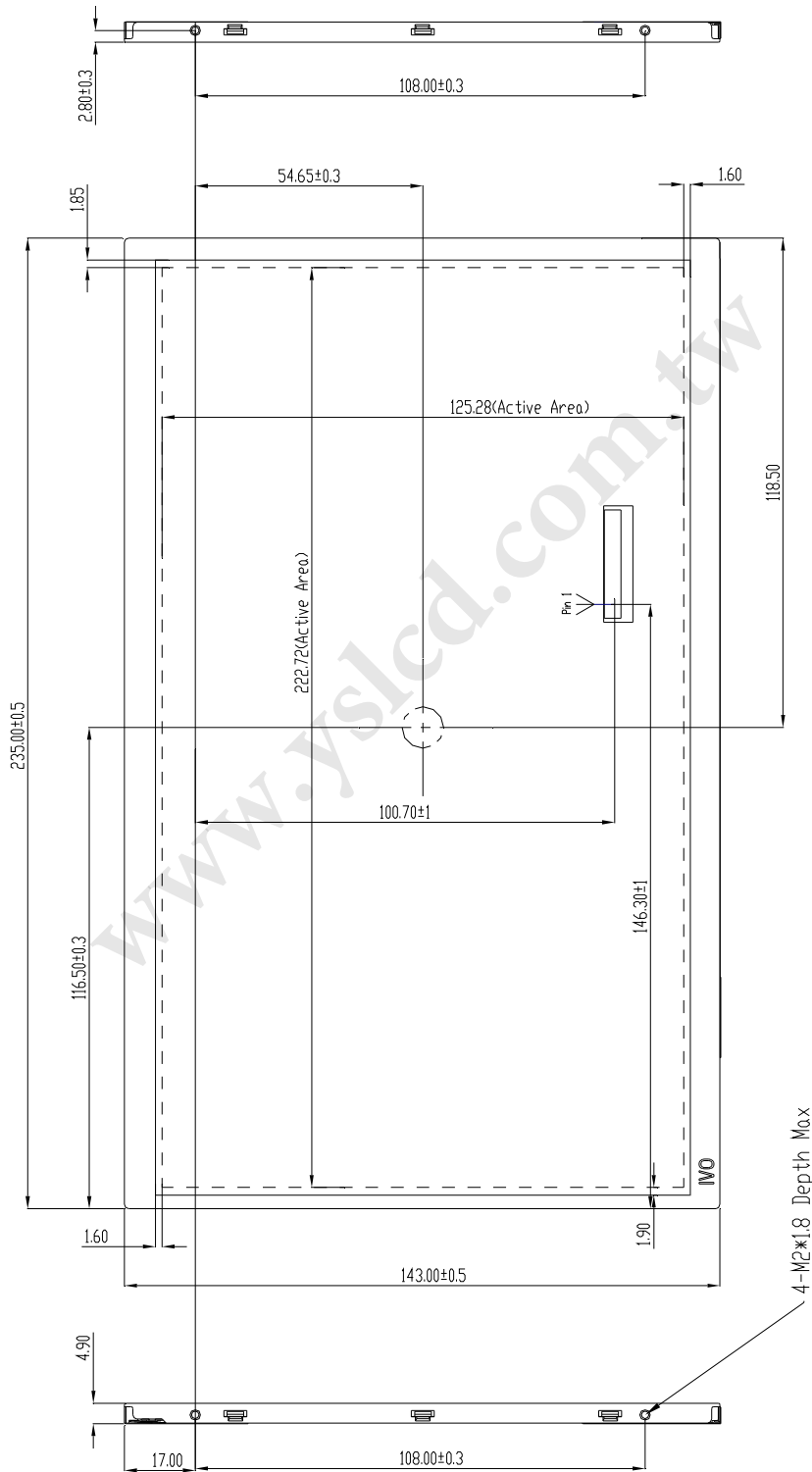

Document Title	M101NWT2 R1 product information			Page No.	20/30
Document No.		Issue Date	2011/11/16	Revision	06

Figure 16 Reference Outline Drawing (Back Side)

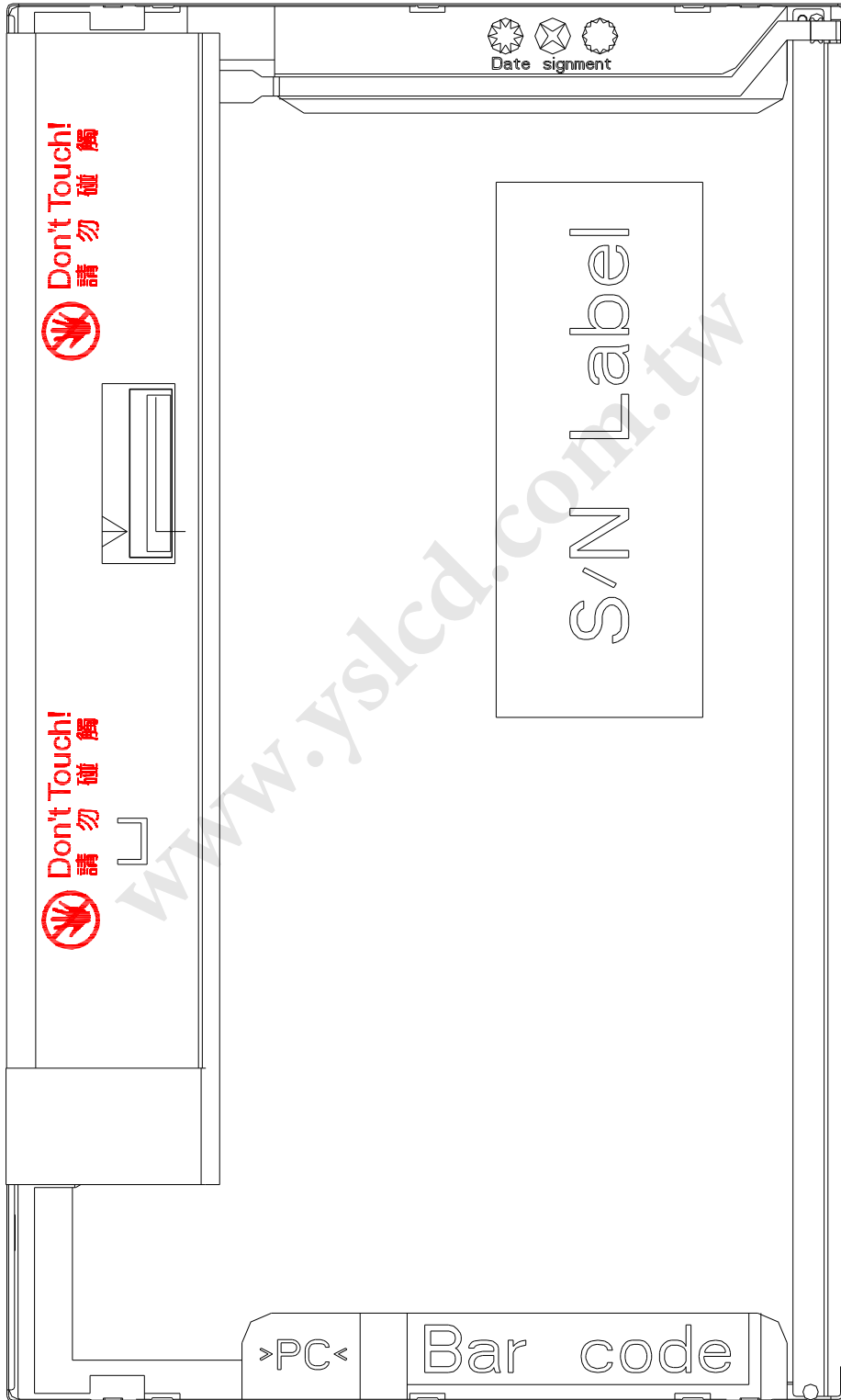

Document Title	M101NWT2 R1 product information			Page No.	21/30
Document No.		Issue Date	2011/11/16	Revision	06

5.1 Dimension Specifications

Table 9

Item		Value	Unit
Width		235.00±0.5	mm
Height		143.00±0.5	mm
Thickness(Max.)		5.2	mm
Bezel Opening	X	226.47±0.5	mm
	Y	128.48±0.5	mm
Weight(Max.)		190	g
BM Width	a-b & c-d	≤1.0	mm

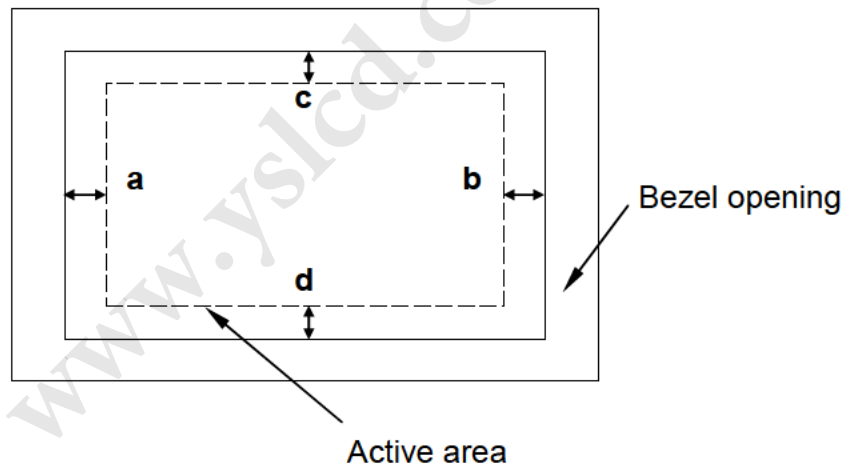

Document Title	M101NWT2 R1 product information			Page No.	22/30
Document No.		Issue Date	2011/11/16	Revision	06

6 Package Specification

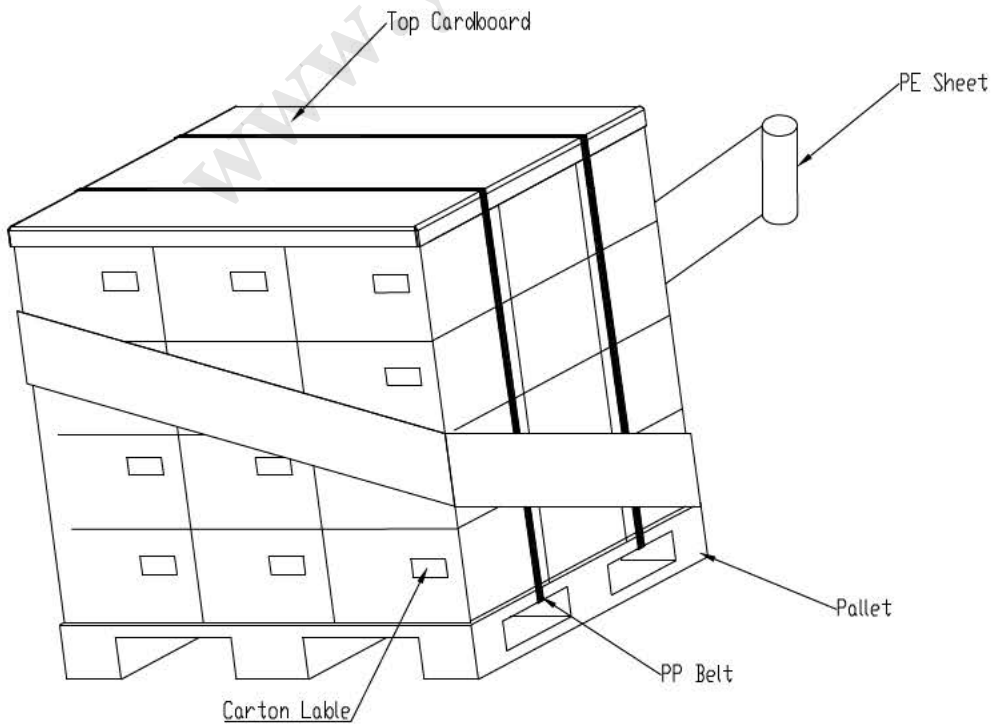
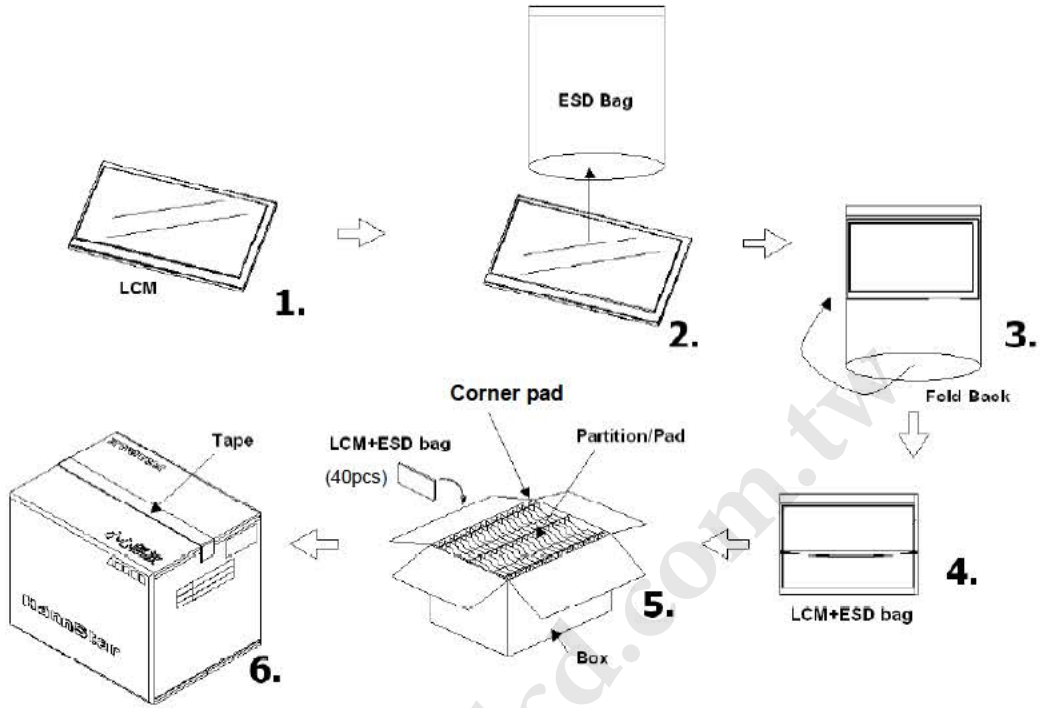

Document Title	M101NWT2 R1 product information			Page No.	23/30
Document No.		Issue Date	2011/11/16	Revision	06

7 Lot Mark

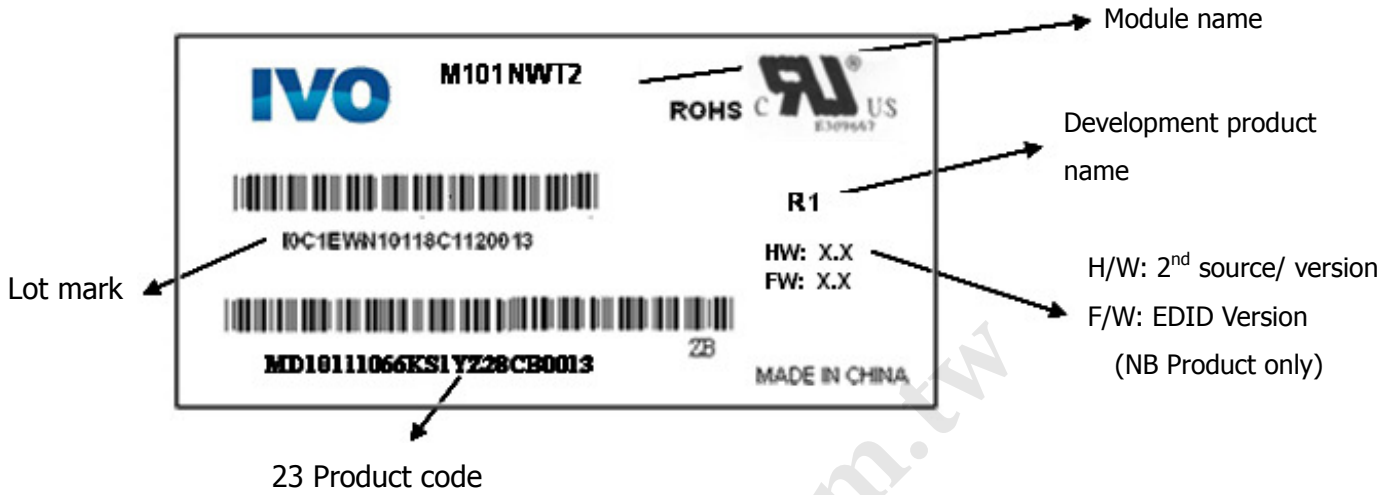

7.1 Lot Mark

1	2	3	4	5	6	7	8	9	10	11	12	13	14	15	16	17	18	19	20
---	---	---	---	---	---	---	---	---	----	----	----	----	----	----	----	----	----	----	----

Code 1,2,4,5,6,7,8,9,10,11,16: IVO internal flow control code.
 Code 3: Production Location.
 Code 12: Production Year.
 Code 13: Production Month.
 Code 14,15: Production Date.
 Code 17,18,19,20: Serial Number.

Note (1) Production Year

Year	2006	2007	2008	2009	2010	2011	2012	2013	2014	2015
Mark	6	7	8	9	A	B	C	D	E	F

Note (2) Production Month

Month	Jan.	Feb.	Mar.	Apr.	May.	Jun.	Jul.	Aug.	Sep.	Oct	Nov.	Dec.
Mark	1	2	3	4	5	6	7	8	9	A	B	C

7.2 23 product barcode

1	2	3	4	5	6	7	8	9	10	11	12	13	14	15	16	17	18	19	20	21	22	23
---	---	---	---	---	---	---	---	---	----	----	----	----	----	----	----	----	----	----	----	----	----	----

Code 1,2: MD Module Domain.
 Code 3,4,5,6,7: IVO Internal Module Name.
 Code 8,9,10,13,16: IVO Internal Flow Control Code.
 Code 11,12: Cell location "Suzhou" is defined as "SZ".

Document Title	M101NWT2 R1 product information			Page No.	24/30
Document No.		Issue Date	2011/11/16	Revision	06

Code 14 ,15: Module line “kunshan” is defined as” KS”.

Code 17,18,19 : Year, Month, Day Refer to IVO Barcode Note(1),Note(2) in Page22.

Code 20~23 : Serial Number.

8 General Precaution

8.1 Use Restriction

This product is not authorized for use in life supporting systems, aircraft navigation control systems, military systems and any other application where performance failure could be life-threatening or otherwise catastrophic.

8.2 Handling Precaution

- 1) Please mount LCD module by using mounting holes arranged in four corners tightly.
- 2) Do not disassemble or modify the module. It may damage sensitive parts inside LCD module, and may cause scratches or dust on the display. IVO does not warrant the module, if customers disassemble or modify the module.
- 3) If LCD panel is broken and liquid crystal spills out, do not ingest or inhale liquid crystal, and do not contact liquid crystal with skin. If liquid crystal contacts mouth or eyes, rinse out with water immediately. If liquid crystal contacts skin or cloths, wash it off immediately with alcohol and Rinse thoroughly with water.
- 4) Disconnect power supply before handling LCD module.
- 5) Refrain from strong mechanical shock and /or any force to the module.
- 6) Do not exceed the absolute maximum rating values, such as the supply voltage variation, input voltage variation, variation in parts' parameters, environmental temperature; etc otherwise LCD module may be damaged. It's recommended employing protection circuit for power supply.
- 7) Do not touch, push or rub the polarizer with anything harder than HB pencil lead. And please do not rub with dust clothes with chemical treatment. Do not touch the surface of polarizer for bare hand or greasy cloth. (Some cosmetics are detrimental to the polarizer.)
- 8) When the surface is dusty, please wipe gently with absorbent cotton or other soft Material. When cleaning the adhesives, please use absorbent cotton wetted with a little petroleum benzene. Normal-hexane is recommended for cleaning the adhesives used to attach front/ rear polarizer. Do not use acetone, toluene and alcohol because they cause chemical damage to the polarizer.
- 9) Wipe off saliva or water drops as soon as possible. Their long time contact with polarizer causes deformations and color fading.
- 10) Protection film must be removed very slowly from the surface of LCD module to prevent from electrostatic occurrence.
- 11) Because LCD module uses CMOS-IC on circuit board and TFT-LCD panel, it is very weak to electrostatic discharge, Please be careful with electrostatic discharge .Persons who handle the module should be grounded through adequate methods.
- 12) Do not adjust the variable resistor located on the module.

8.3 Storage Precaution

- 1) Please do not leave LCD module in the environment of high humidity and high temperature for a long time.
- 2) The module shall not be exposed under strong light such as direct sunlight. Otherwise, Display characteristics may be changed.
- 3) The module should be stored in a dark place. It is prohibited to apply sunlight or fluorescent light in storage.



Document Title	M101NWT2 R1 product information			Page No.	25/30
Document No.		Issue Date	2011/11/16	Revision	06

8.4 Operation Precaution

- 1) Do not connect or disconnect the module in the "Power On" condition.
- 2) Power supply should always be turned on/off by 9.0 "Power on/off sequence".
- 3) Module has high frequency circuits. Sufficient suppression to the electromagnetic interference should be done by system manufacturers. Grounding and shielding methods may be important to minimize the interference.
- 4) After installation of the TFT Module into an enclosure, do not twist nor bend the TFT Module even momentary. At designing the enclosure, it should be taken into consideration that no bending/twisting forces are applied to the TFT Module from outside. Otherwise the TFT Module may be damaged.

8.5 Others

- 1) Ultra-violet ray filter is necessary for outdoor operation.
- 2) Avoid condensation of water which may result in improper operation or disconnection of electrode.
- 3) If the module keeps displaying the same pattern for a long period of time, the image may be "Sticked" to the screen.
- 4) This module has its circuitry PCB on the rear side and should be handled carefully in order not to be stressed.

8.6 Disposal

When disposing LCD module, obey the local environmental regulations.

Document Title	M101NWT2 R1 product information			Page No.	26/30
Document No.		Issue Date	2011/11/16	Revision	06

9 EDID Data Structure

Address	Address	Field Name & Comments	Value	Value	Value
(Decimal)	(HEX)		(HEX)	(BIN)	(DEC)
0	0	Header	00	00000000	0
1	1	Header	FF	11111111	255
2	2	Header	FF	11111111	255
3	3	Header	FF	11111111	255
4	4	Header	FF	11111111	255
5	5	Header	FF	11111111	255
6	6	Header	FF	11111111	255
7	7	Header	00	00000000	0
8	8	Manufacture Code	26	00100110	38
9	9	Manufacture Code	CF	11001111	207
10	0A	Product Code	F4	11110100	244
11	0B	Product Code	03	00000011	3
12	0C	LCD module Serial No –("0" if not used)	00	00000000	0
13	0D	LCD module Serial No –("0" if not used)	00	00000000	0
14	0E	LCD module Serial No –("0" if not used)	00	00000000	0
15	0F	LCD module Serial No –("0" if not used)	00	00000000	0
16	10	Week of Manufacture	0A	00001010	10
17	11	Year of Manufacture	14	00010100	20
18	12	EDID Structure Ver # = 1	01	00000001	1
19	13	EDID revision # = 3	03	00000011	3
20	14	Video I/P definition = Digital I/P (80h)	80	10000000	128
21	15	Max H Image Size = (Rounded to cm)	16	00010110	22
22	16	Max V Image Size = (Rounded to cm)	0D	00001101	13
23	17	Display Gamma	78	01111000	120
24	18	Feature Support (No DPMS, Active off, RGB, Timing BLK 1)	0A	00001010	10
25	19	Red/Green Low bits (RxRy/GxGy)	21	00100001	33
26	1A	Blue/White Low bits (BxBY/WxWy)	D0	11010000	208
27	1B	Red X Rx	94	10010100	148

Document Title	M101NWT2 R1 product information			Page No.	27/30
Document No.		Issue Date	2011/11/16	Revision	06

28	1C	Red Y Ry	58	01011000	88
29	1D	Green X Gx	56	01010110	86
30	1E	Green Y Gy	8F	10001111	143
31	1F	Blue X Bx	27	00100111	39
32	20	Blue Y By	1F	00011111	31
33	21	White X Wx	50	01010000	80
34	22	White Y Wy	54	01010100	84
35	23	Established timings 1 (00h if not used)	00	00000000	0
36	24	Established timing 2 (00h if not used)	00	00000000	0
37	25	Manufacturer's timings (00h if not used)	00	00000000	0
38	26	Standard timing ID1 (01h if not used)	01	00000001	1
39	27	Standard timing ID1 (01h if not used)	01	00000001	1
40	28	Standard timing ID2 (01h if not used)	01	00000001	1
41	29	Standard timing ID2 (01h if not used)	01	00000001	1
42	2A	Standard timing ID3 (01h if not used)	01	00000001	1
43	2B	Standard timing ID3 (01h if not used)	01	00000001	1
44	2C	Standard timing ID4 (01h if not used)	01	00000001	1
45	2D	Standard timing ID4 (01h if not used)	01	00000001	1
46	2E	Standard timing ID5 (01h if not used)	01	00000001	1
47	2F	Standard timing ID5 (01h if not used)	01	00000001	1
48	30	Standard timing ID6 (01h if not used)	01	00000001	1
49	31	Standard timing ID6 (01h if not used)	01	00000001	1
50	32	Standard timing ID7 (01h if not used)	01	00000001	1
51	33	Standard timing ID7 (01h if not used)	01	00000001	1
52	34	Standard timing ID8 (01h if not used)	01	00000001	1
53	35	Standard timing ID8 (01h if not used)	01	00000001	1
54	36	Pixel Clock LSB	B0	10110000	176
55	37	Pixel Clock HSB	13	00010011	19
56	38	Horizontal Active (lower 8 bits)	00	00000000	0
57	39	Hor blanking (lower 8 bits)	40	01000000	64
58	3A	Horizontal Active/Horizontal blanking (upper4:4 bits)	41	01000001	65
59	3B	Vertical active(lower 8 bits)	58	01011000	88
60	3C	Vertical blanking(lower 8 bits)	19	00011001	25

Document Title	M101NWT2 R1 product information			Page No.	28/30
Document No.		Issue Date	2011/11/16	Revision	06

61	3D	Vertical Active : Vertical Blanking (upper4:4 bits)	20	00100000	32
62	3E	Horizontal Sync Offset	30	00110000	48
63	3F	Horizontal Sync Pulse Width	20	00100000	32
64	40	Vertical Sync Offset , Sync Width	3A	00111010	58
65	41	Horizontal Vertical Sync Offset/Width upper 2 bits	00	00000000	0
66	42	Horizontal Image Size	DF	11011111	223
67	43	Vertical Image Size	7D	01111101	125
68	44	Horizontal Image Size / Vertical image size	00	00000000	0
69	45	Horizontal Border = (0 for Notebook LCD)	00	00000000	0
70	46	Vertical Border = (0 for Notebook LCD)	00	00000000	0
71	47	Non-interlaced, Normal, No stereo, Separate sync, H/V Pol Negatives,	19	00011001	25
72	48	Timing Descriptor #2	00	00000000	0
73	49		00	00000000	0
74	4A		00	00000000	0
75	4B		0F	00001111	15
76	4C		00	00000000	0
77	4D		00	00000000	0
78	4E		00	00000000	0
79	4F		00	00000000	0
80	50		00	00000000	0
81	51		00	00000000	0
82	52		00	00000000	0
83	53		00	00000000	0
84	54		00	00000000	0
85	55		00	00000000	0
86	56		00	00000000	0
87	57		00	00000000	0
88	58		00	00000000	0
89	59	Module revision	01	00000001	1
90	5A	Detailed timing/monitor descriptor#3	00	00000000	0
91	5B	Flag	00	00000000	0

Document Title	M101NWT2 R1 product information			Page No.	29/30
Document No.		Issue Date	2011/11/16	Revision	06

92	5C	Flag	00	00000000	0
93	5D	FE (hex) defines ASCII string	FE	11111110	254
94	5E	Flag	00	00000000	0
95	5F	Manufacture l	49	01001001	73
96	60	Manufacture n	6E	01101110	110
97	61	Manufacture f	66	01100110	102
98	62	Manufacture o	6F	01101111	111
99	63	Manufacture v	56	01010110	86
100	64	Manufacture i	69	01101001	105
101	65	Manufacture s	73	01110011	115
102	66	Manufacture i	69	01101001	105
103	67	Manufacture o	6F	01101111	111
104	68	Manufacture n	6E	01101110	110
105	69	New line character indicates end of ASCII string	0A	00001010	10
106	6A		20	00100000	32
107	6B		20	00100000	32
108	6C	Detailed timing/monitor descriptor #4	00	00000000	0
109	6D		00	00000000	0
110	6E		00	00000000	0
111	6F	FE (hex) defines ASCII string	FE	11111110	254
112	70	Flag	00	00000000	0
113	71	Manufacture P/N	4D	01001101	77
114	72	Manufacture P/N	31	00110001	49
115	73	Manufacture P/N	30	00110000	48
116	74	Manufacture P/N	31	00110001	49
117	75	Manufacture P/N	4E	01001110	78
118	76	Manufacture P/N	57	01010111	87
119	77	Manufacture P/N	54	01010100	84
120	78	Manufacture P/N	32	00110010	50
121	79	Manufacture P/N	20	00100000	32
122	7A	Manufacture P/N	52	01010010	82
123	7B	Manufacture P/N	31	00110001	49



Document Title	M101NWT2 R1 product information			Page No.	30/30
Document No.		Issue Date	2011/11/16	Revision	06

124	7C	New line character indicates end of ASCII string	20	00100000	32
125	7D		0A	00001010	10
126	7E	Extension Flag = 00	00	00000000	0
127	7F	Checksum	12	00010010	18

www.yslcd.com.tw