



Document Name	M101NWWB R3 Customer Approval Specification			Page 1 of 23	
Document No.	A-M101NWWB-R3-342-02	Made/Revised Date	2016/06/07	Ver.	01

## Customer Approval Specification

**To:** 三亚科技股份有限公司

**Product Name: M101NWWB R3**

**Document Issue Date: 2016/6/07**

Customer	InfoVision Optoelectronics
<p><b><u>SIGNATURE</u></b></p> <p>_____</p> <p>_____</p> <p>_____</p> <p>Please return 1 copy for your confirmation with your signature and comments.</p>	<p><b><u>SIGNATURE</u></b></p> <p><b>REVIEWED BY</b></p> <p><b>CQM</b></p> <p>_____</p> <p><b>PREPARED BY</b></p> <p><b>FAE</b></p> <p>_____</p>

- Note: 1. Please contact InfoVision Company before designing your product based on this product.  
 2. The information contained herein is presented merely to indicate the characteristics and performance of our products. No responsibility is assumed by IVO for any intellectual property claims or other problems that may result from application based on the module described herein.

FQ-7-30-0-009-03D



Document Name	M101NWWB R3 Customer Approval Specification			Page 3 of 23	
Document No.	A-M101NWWB-R3-342-02	Made/Revised Date	2016/06/07	Ver.	01

## CONTENTS

<b>1.0 GENERAL DESCRIPTIONS</b>	<b>4</b>
<b>2.0 ABSOLUTE MAXIMUM RATINGS</b>	<b>6</b>
<b>3.0 OPTICAL CHARACTERISTICS</b>	<b>7</b>
<b>5.0 MECHANICAL CHARACTERISTICS</b>	<b>17</b>
<b>6.0 RELIABILITY CONDITIONS</b>	<b>19</b>
<b>7.0 PACKAGE SPECIFICATION</b>	<b>20</b>
<b>8.0 LOT MARK</b>	<b>21</b>
<b>9.0 GENERAL PRECAUTION</b>	<b>22</b>



Document Name	M101NWWB R3 Customer Approval Specification			Page 4 of 23	
Document No.	A-M101NWWB-R3-342-02	Made/Revised Date	2016/06/07	Ver.	01

## 1.0 General Descriptions

### 1.1 Introduction

The M101NWWB R3 is a color active matrix thin film transistor (TFT) liquid crystal display (LCD) that uses amorphous silicon TFT as a switching device. This model is composed of a TFT LCD panel, a driver circuit and a backlight system. This TFT LCD has a 10.1 inch diagonally measured active display area with WXGA resolution (1280 horizontal by 800 vertical pixels array).

### 1.2 Features

- Supported WXGA Resolution
- LVDS Interface
- Wide View Angle
- Compatible with RoHS Standard

### 1.3 Product Summary

Items	Specifications		Unit
Screen Diagonal	10.1		inch
Active Area (H x V)	216.96 x135.60		mm
Number of Pixels (H x V)	1280x800		-
Pixel Pitch (H x V)	0.1695x0.1695		mm
Pixel Arrangement	R.G.B. Vertical Stripe		-
Display Mode	Normally Black		-
White Luminance	350 (Typ.)		cd /m <sup>2</sup>
Contrast Ratio	800)(Typ.)		-
Response Time	25(Typ.)		ms
Input Voltage	3.3 (Typ.)		V
Logical power consumption (At White Pattern)	1.2 (Max.)		W
Backlight power consumption	2.5 (Max.)		W
Weight	160(Max.)		g
Outline Dimension (H x V x D)	w/o PCB	229.46(Typ.) x149.1(Typ.)x2.8(Max.)	mm
	w/ PCB	229.46(Typ.) x149.1(Typ.)x4.56(Max.)	
Electrical Interface (Logic)	LVDS		-
Support Color	16.7 M		-
NTSC	45 (Typ.)		%
Viewing Direction	All		-
Surface Treatment	Glare , Hard –Coating 3H		-

Document Name	M101NWWB R3 Customer Approval Specification			Page 5 of 23	
Document No.	A-M101NWWB-R3-342-02	Made/Revised Date	2016/06/07	Ver.	01

### 1.4 Functional Block Diagram

Figure 1 shows the functional block diagram of the LCD module.

Figure 1 Block Diagram

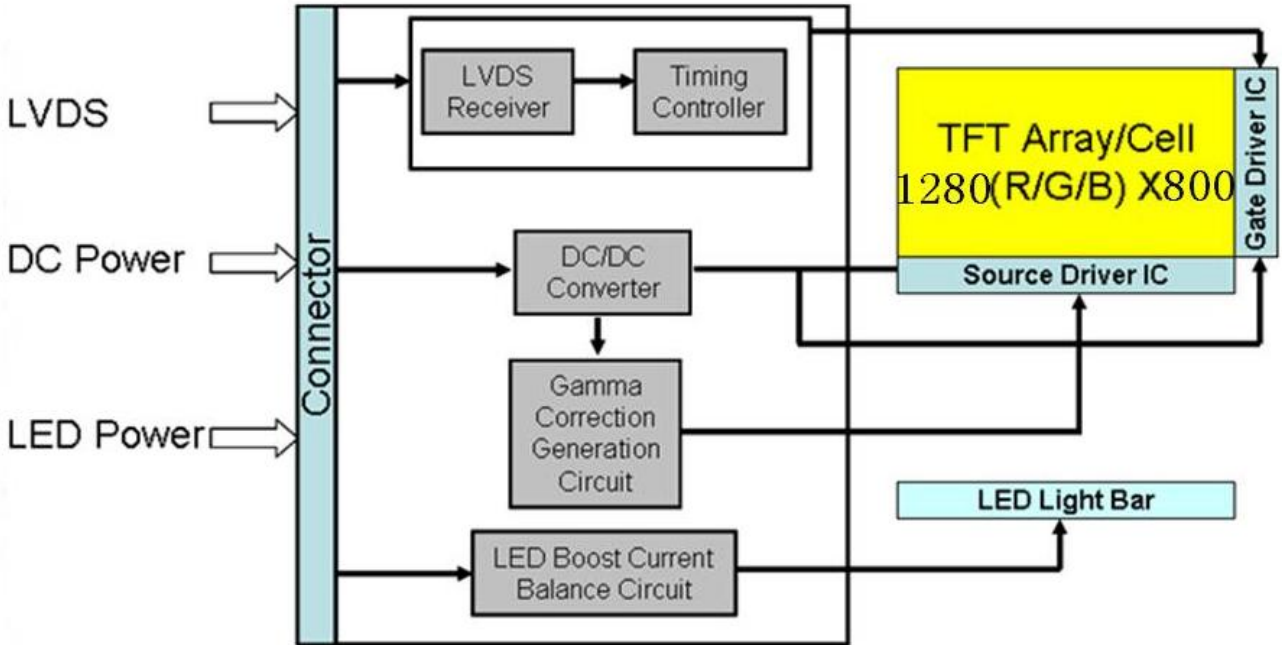

### 1.5 Pixel Mapping

Figure2 Pixel Mapping

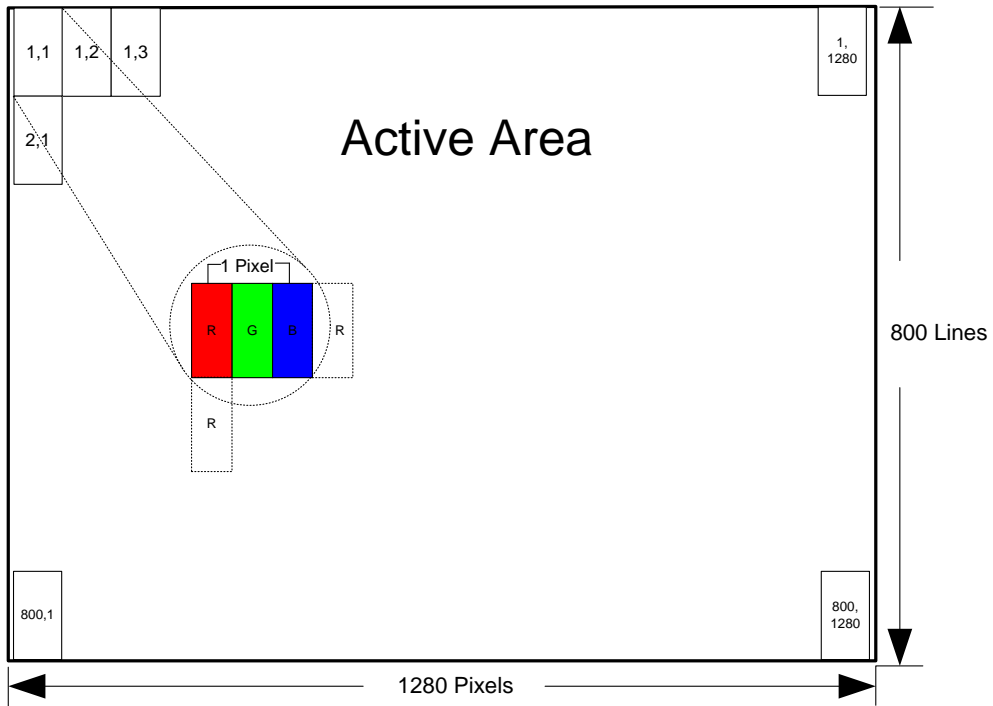

Document Name	M101NWWB R3 Customer Approval Specification			Page 6 of 23	
Document No.	A-M101NWWB-R3-342-02	Made/Revised Date	2016/06/07	Ver.	01

## 2.0 Absolute Maximum Ratings

**Table 1 Electrical & Environment Absolute Rating**

Item	Symbol	Min.	Max.	Unit	Note
Logic Supply Voltage	V <sub>DD</sub>	-0.3	4.0	V	(1),(2)
Operating Temperature	T <sub>OP</sub>	-20	70	°C	(3),(4),(5),(6)
Storage Temperature	T <sub>ST</sub>	-30	80	°C	
Vibration(Non-operating)	VB	-	1.5	G	(7)
Shock(Non-operating)	Shock	-	240	G	(8)

Note (1) Permanent damage may occur to the LCD module if beyond this specification. Functional operation should be restricted to the conditions described under normal operating conditions.

Note (2) Operating temperature 25°C, humidity 55%RH.

Note (3) (T<=40°C) Note static electricity.Maximum wet bulb temperature at 39°C or less. (T>40°C) No condensation.

Note (4) There is a possibility of causing deterioration in the irregularity and others of the screen and the display fineness though the liquid crystal module doesn't arrive at destruction when using it at 70~80°C or -30~-20°C.

Note (5) There is a possibility of causing the fineness deterioration by the prolonged use in the (high temperature) humidity environment (60%RH or more).

Note (6) In the operating temperature item, the low temperature side is the ambient temperature regulations. The high temperature side is the panel surface temperature regulations.

**Figure 3 Absolute Ratings of Environment of the LCD Module**

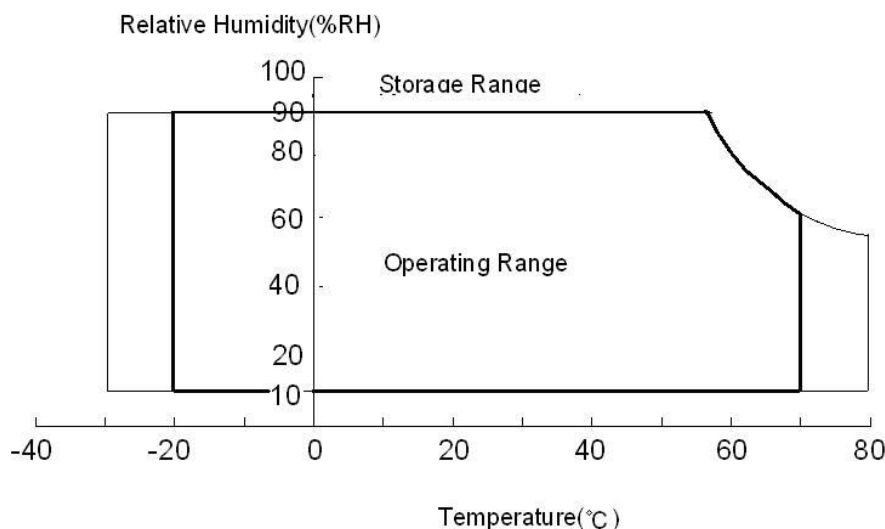

Note (7) 10-500Hz, random vibration, 1h for X, Y, Z axis.

Note (8) 6ms, half sine wave, one time for X, Y, Z axis.



Document Name	M101NWWB R3 Customer Approval Specification			Page 7 of 23	
Document No.	A-M101NWWB-R3-342-02	Made/Revised Date	2016/06/07	Ver.	01

### 3.0 Optical Characteristics

The optical characteristics are measured under stable conditions as following notes.

**Table 2 Optical Characteristics**

Item	Conditions	Min.	Typ.	Max.	Unit	Note		
Viewing Angle (CR>10)	Horizontal	$\theta_{x+}$	75	85	-	degree  (1),(2),(3)		
		$\theta_{x-}$	75	85	-			
	Vertical	$\theta_{y+}$	75	85	-			
		$\theta_{y-}$	75	85	-			
Contrast Ratio	Center	600	800	-	-	(1),(2),(4) $\theta_x=\theta_y=0^\circ$		
Response Time	Rising + Falling	-	25	50	ms	(1),(2),(5) $\theta_x=\theta_y=0^\circ$		
Color Chromaticity (CIE1931)	Red x	Typ. -0.03	0.582	Typ. +0.03	-	(1),(2),(3) $\theta_x=\theta_y=0^\circ$		
	Red y		0.347		-			
	Green x		0.349		-			
	Green y		0.573		-			
	Blue x		0.164		-			
	Blue y		0.143		-			
	White x		Typ. -0.03		0.313		Typ. +0.03	-
	White y		0.329		-			
NTSC	-	42	45	-	%	(1),(2),(3) $\theta_x=\theta_y=0^\circ$		
White Luminance	Center	300	350	-	cd/m <sup>2</sup>	(1),(2),(6)		
Luminance Uniformity	9 Points	70	75	-	%	(1),(2),(6) $\theta_x=\theta_y=0^\circ$		

Note (1) Measurement Setup:

The LCD module should be stabilized at given temperature(25°C) for 15 minutes to avoid abrupt temperature change during measuring. In order to stabilize the luminance, the measurement should be executed after lighting backlight for 15 minutes in a windless room.

Document Name	M101NWWB R3 Customer Approval Specification			Page 8 of 23	
Document No.	A-M101NWWB-R3-342-02	Made/Revised Date	2016/06/07	Ver.	01

**Figure 4 Measurement Setup**

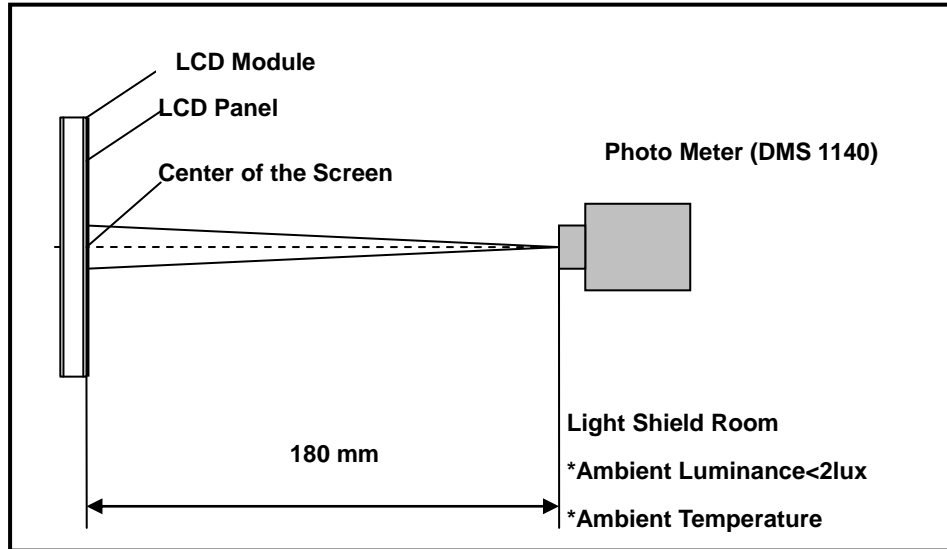

Note (2) The LED input parameter setting as:

I\_LED: 80mA

PWM\_LED: duty 100 %

Note (3) Definition of Viewing Angle

**Figure 5 Definition of Viewing Angle**

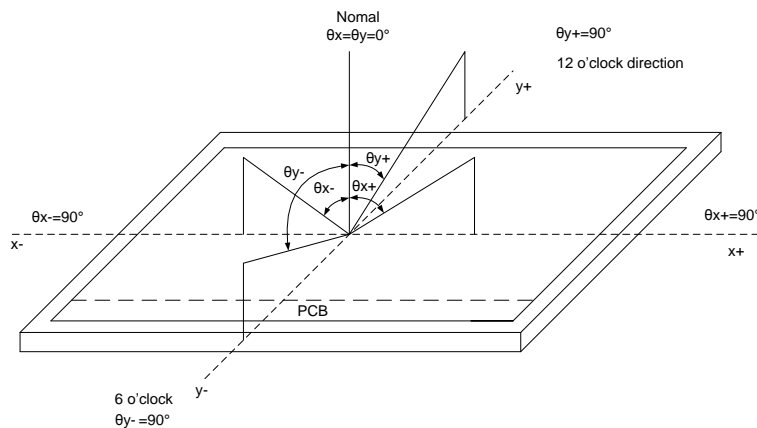

Note (4) Definition Of Contrast Ratio (CR)

The contrast ratio can be calculated by the following expression

$$\text{Contrast Ratio (CR)} = L_{255} / L_0$$

L255: Luminance of gray level 255, L0: Luminance of gray level 0

Note (5) Definition Of Response Time ( $T_R$ ,  $T_F$ )



Document Name	M101NWWB R3 Customer Approval Specification			Page 9 of 23	
Document No.	A-M101NWWB-R3-342-02	Made/Revised Date	2016/06/07	Ver.	01

**Figure 6 Definition of Response Time**

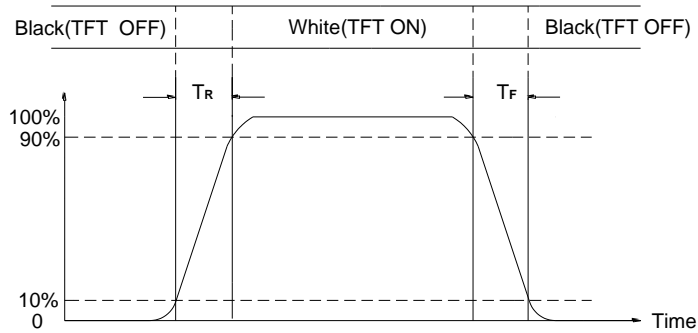

Note (6) Definition Of brightness Luminance

Measure the luminance of gray level 255 at 9 points.

Luminance Uniformity=  $\text{Min.}(L1, L2, \dots L9) / \text{Max.}(L1, L2, \dots L9)$

H—Active Area Width, V—Active Area Height, L—Luminance

**Figure 6 Measurement Locations of 9 Points**

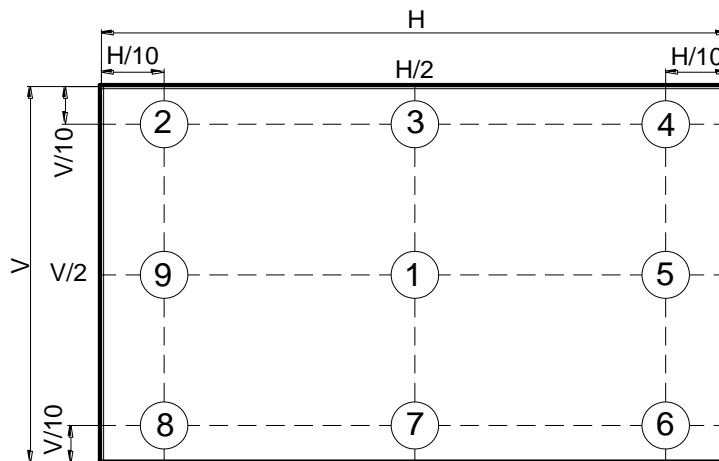



Document Name	M101NWWB R3 Customer Approval Specification			Page 10 of 23	
Document No.	A-M101NWWB-R3-342-02	Made/Revised Date	2016/06/07	Ver.	01

#### 4.0 Electrical Characteristics

##### 4.1 Interface Connector

**Table 3 Signal Connector Type**

Item	Description
Manufacturer / Type	Starconn / 300E40-0010RA-G3
Mating Receptacle / Type (Reference)	111B40-1211TA-G3 or Compatible

**Table 4 Signal Connector Pin Assignment**

Pin #	Signal Name	Description	Remarks
1	NC	No Connection	-
2	VDD	Power Supply	-
3	VDD	Power Supply	-
4	VDD_EDID	VDD_EDID	-
5	SCL_EDID	SCL_EDID	-
6	SDA_EDID	SDA_EDID	-
7	NC	No Connection	-
8	LV0N	-LVDS Differential Data Input	-
9	LV0P	+LVDS Differential Data Input	
10	GND	Ground	-
11	LV1N	-LVDS Differential Data Input	-
12	LV1P	+LVDS Differential Data Input	
13	GND	Ground	-
14	LV2N	-LVDS Differential Data Input	-
15	LV2P	+LVDS Differential Data Input	
16	GND	Ground	-
17	LVCLKN	-LVDS Differential Clock Input	-
18	LVCLKP	+LVDS Differential Clock Input	
19	GND	Ground	-
20	LV3N	-LVDS Differential Data Input	-
21	LV3P	+LVDS Differential Data Input	
22	GND	Ground	-
23	LED_GND	Ground for LED Driving	-
24	LED_GND	Ground for LED Driving	-
25	LED_GND	Ground for LED Driving	-
26	NC	No Connection	-
27	LED_PWM	PWM Input Signal for LED Driver	-



Document Name	M101NWWB R3 Customer Approval Specification			Page 11 of 23	
Document No.	A-M101NWWB-R3-342-02	Made/Revised Date	2016/06/07	Ver.	01

28	LED_EN	LED Enable Pin	-
29	NC	Reserved For CABG	-
30	NC	No Connection	
31	LED_VCC	Power Supply for LED Driver	
32	LED_VCC	Power Supply for LED Driver	
33	LED_VCC	Power Supply for LED Driver	
34	NC	No Connection	
35	BIST	BIST pin	Active high
36	NC	No Connection	
37	NC	No Connection	
38	NC	No Connection	
39	NC	No Connection	
40	NC	No Connection	

## 4.2 Signal Electrical Characteristics

### 4.2.1 Signal Electrical Characteristics For LVDS Receiver

The built-in LVDS receiver is compatible with (ANSI/TIA/TIA-644 ) standard.

**Table 5 LVDS Receiver Electrical Characteristics**

Parameter	Symbol	Min.	Typ.	Max.	Unit	Conditions
Differential Input High Threshold	V <sub>th</sub>	-	-	+100	mV	V <sub>CM</sub> =+1.2V
Differential Input Low Threshold	V <sub>tl</sub>	-100	-	-	mV	V <sub>CM</sub> =+1.2V
Magnitude Differential Input Voltage	V <sub>ID</sub>	100	-	600	mV	-
Common Mode Voltage	V <sub>CM</sub>	V <sub>ID</sub>  /2	-	2.4- V <sub>ID</sub>  /2	V	-

Note (1) Input signals shall be low or Hi- resistance state when VDD is off.

Note (2) All electrical characteristics for LVDS signal are defined and shall be measured at the interface connector of LCD.

Document Name	M101NWWB R3 Customer Approval Specification			Page 12 of 23	
Document No.	A-M101NWWB-R3-342-02	Made/Revised Date	2016/06/07	Ver.	01

**Figure 8 Voltage Definitions**

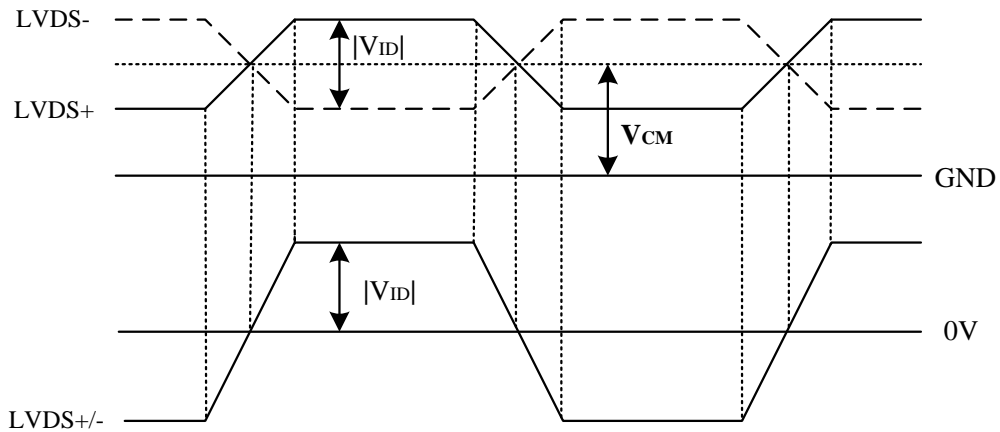

**Figure 9 LVDS Data Mapping**

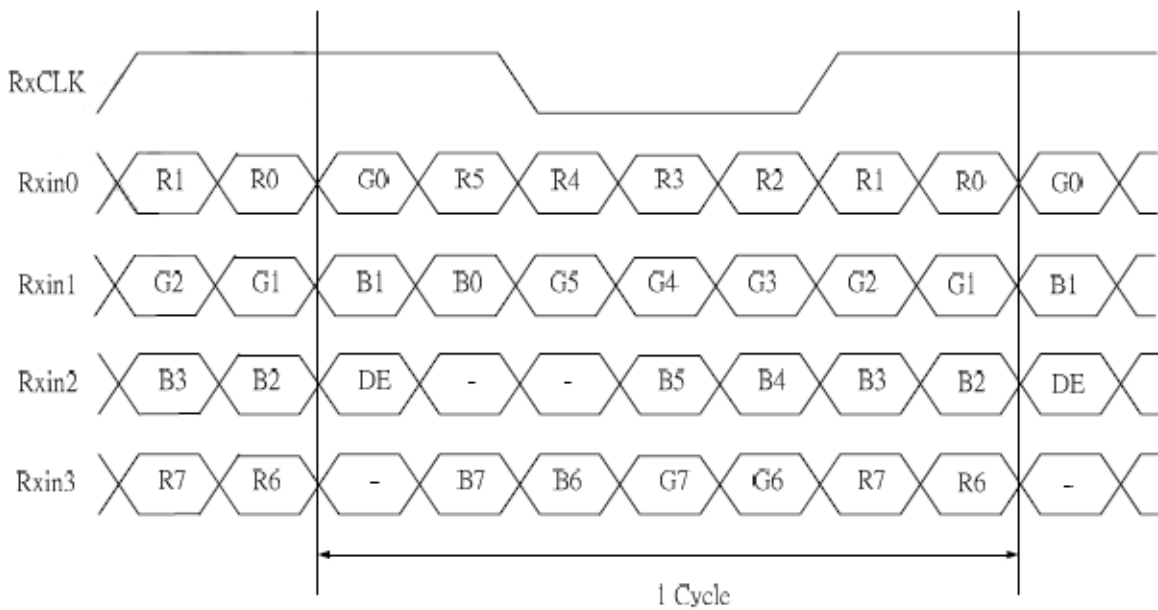

Document Name	M101NWWB R3 Customer Approval Specification			Page 13 of 23	
Document No.	A-M101NWWB-R3-342-02	Made/Revised Date	2016/06/07	Ver.	01

### 4.3 Interface Timings

**Table 6 Interface Timings**

Parameter	Symbol	Unit	Min.	Typ.	Max.
Frame Rate	--	Hz	-	60	-
Frame Period	TV	line	815	823	1023
Vertical Display Time	TVD	line	800		
Vertical Blanking Time	TVW+TVBP+TVFP	line	15	23	33
1 Line Scanning Time	TH	clock	1410	1440	1470
Horizontal Display Time	THD	clock	1280		
Horizontal Blanking Time	THW+THBP+THFP	clock	60	160	190
Clock Rate	1/TC	MHz	68.9	71.1	73.4

#### 4.3.1 Timing Diagram of Interface Signal (DE mode)

**Figure 10 Timing Characteristics**

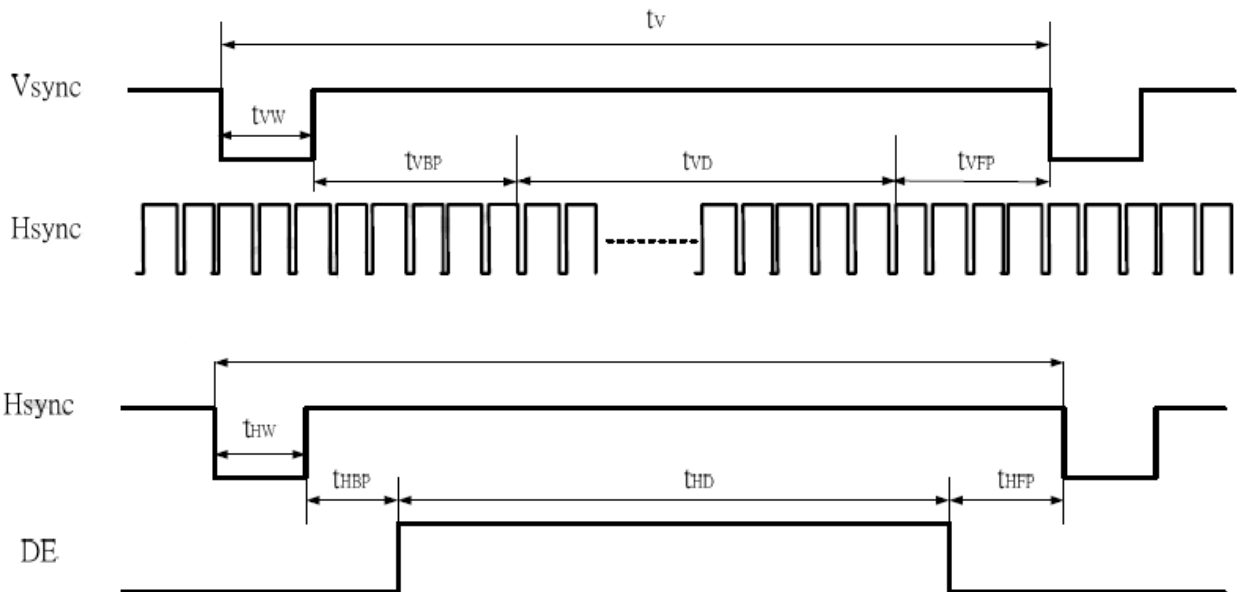



Document Name	M101NWWB R3 Customer Approval Specification			Page 14 of 23	
Document No.	A-M101NWWB-R3-342-02	Made/Revised Date	2016/06/07	Ver.	01

#### 4.4 Input Power Specifications

Input power specifications are as follows.

**Table 7 Input Power Specifications**

Parameter	Symbol	Min.	Typ.	Max.	Unit	Note	
<b>System Power Supply</b>							
LCD Drive Voltage (Logic)	$V_{DD}$	3.0	3.3	3.6	V	(2), (4)	
VDD Current	White Pattern	$I_{DD}$	-	0.295	-	A	(3),(4),
VDD Power Consumption	White Pattern	$P_{DD}$	-	-	1.2	W	
Rush Current		$I_{Rush}$	-	-	1.5	A	(1),(4),(5)
Allowable Logic/LCD Drive Ripple Voltage		$V_{VDD-RP}$	-	-	300	mV	(4)
<b>LED Power Supply</b>							
LED Input Voltage	$V_{LED}$	6	12	21	V	(4)	
LED Power Consumption	$P_{LED}$	-	-	2.5	W	(4)	
LED Forward Voltage	$V_F$	2.8	-	3.2	V	(4)	
LED Forward Current	$I_F$	-	20	-	mA		
PWM Signal Voltage	High	$V_{PWM}$	3.0	-	3.6		V
	Low		0	-	0.4		
LED Enable Voltage	High	$V_{LED\_EN}$	3.0	-	3.6		V
	Low		0	-	0.4		
Input PWM Frequency		$F_{PWM}$	100	-	200	Hz	$D_{DIM} \geq 0.1\%$
			200	-	500		$D_{DIM} \geq 0.25\%$
			500	-	1000		$D_{DIM} \geq 0.5\%$
			1000	-	2000		$D_{DIM} \geq 1\%$
			2000	-	5000		$D_{DIM} \geq 2.5\%$
			5000	-	10000		$D_{DIM} \geq 5\%$
			10000	-	20000		$D_{DIM} \geq 10\%$
			20000	-	30000		$D_{DIM} \geq 15\%$
LED Life Time	LT	20,000	25,000	-	Hours	(3)(6)	

Document Name	M101NWWB R3 Customer Approval Specification			Page 15 of 23	
Document No.	A-M101NWWB-R3-342-02	Made/Revised Date	2016/06/07	Ver.	01

Note (1) Measure Condition

**Figure 9 VDD Rising Time**

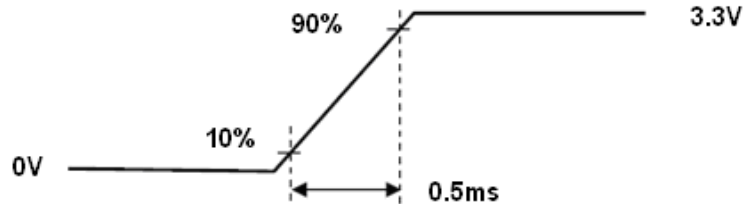

Note (2) VDD Power Dip Condition

$V_{TH} < V_{DD} \leq V_{min}$ ,  $t_d \leq 10ms$  (a time of the voltage return to normal), our panel can revive automatically.

**Figure 10 VDD Power Dip**

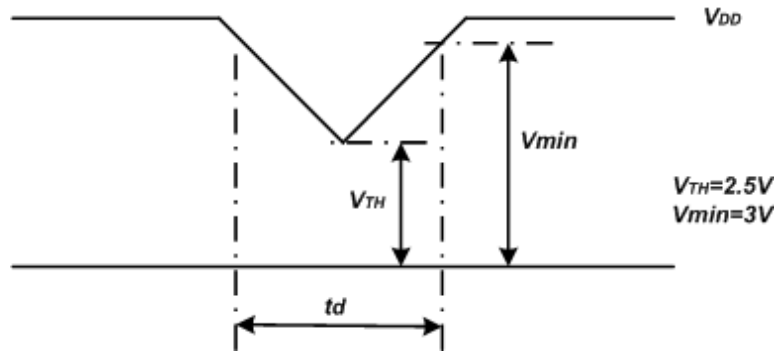

Note (3) Frame Rate=60Hz, VDD=3.3V, DC Current.

Note (4) Operating temperature 25°C, humidity 55%RH.

Note (5) The reference measurement circuit of rush current.

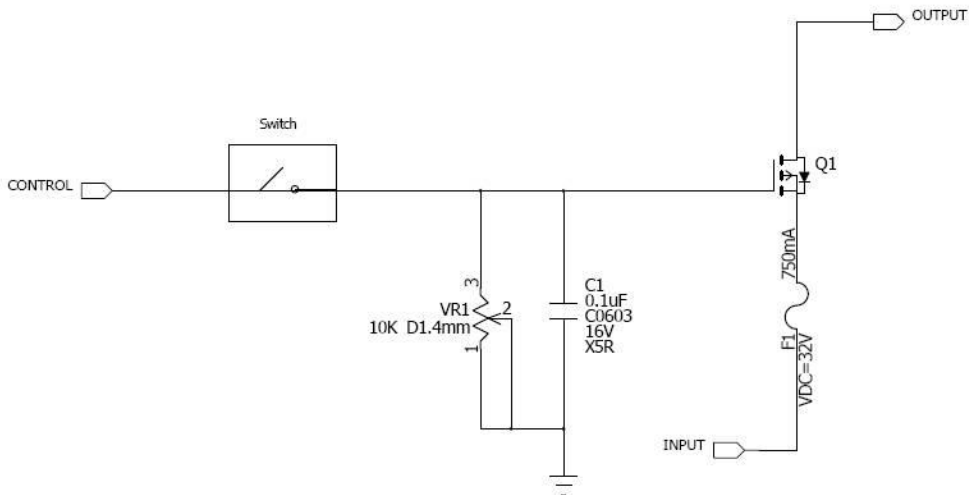

Note (6) The LED life time define as the estimated time to 50% degradation of initial luminous.

Document Name	M101NWWB R3 Customer Approval Specification			Page 16 of 23	
Document No.	A-M101NWWB-R3-342-02	Made/Revised Date	2016/06/07	Ver.	01

**4.5 Power ON/OFF Sequence**

Interface signals are also shown in the chart. Signals from any system shall be Hi- resistance state or low level when VDD voltage is off.

**Figure 11 Power Sequence**

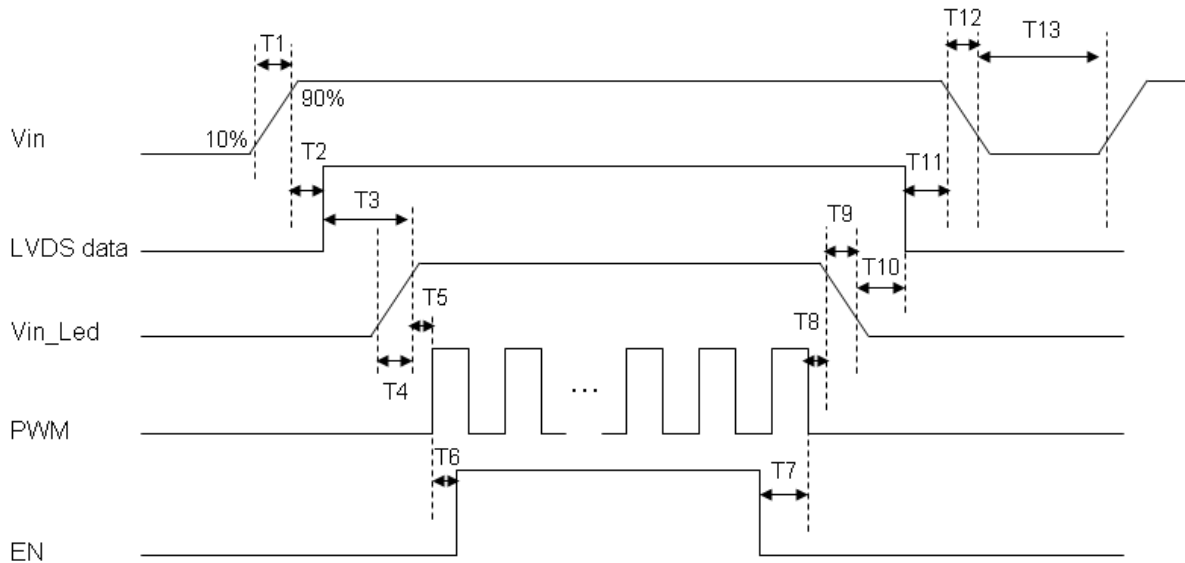

**Table 8 Power Sequencing Requirements**

Parameter	Symbol	Unit	Min	Typ.	Max
VIN Rise Time	T1	ms	0.5	--	10
VIN Good to Signal Valid	T2	ms	30	--	90
Signal Valid to Backlight On	T3	ms	200	--	--
Backlight Power On Time	T4	ms	0.5	--	--
Backlight VDD Good to System PWM On	T5	ms	10	--	--
System PWM ON to Backlight Enable ON	T6	ms	10	--	--
Backlight Enable Off to System PWM Off	T7	ms	0	--	--
System PWM Off to B/L Power Disable	T8	ms	200	--	--
Backlight Power Off Time	T9	ms	0.5	10	30
Backlight Off to Signal Disable	T10	ms	200	--	--
Signal Disable to Power Down	T11	ms	0	--	50
VIN Fall Time	T12	ms	0.5	10	30
Power Off	T13	ms	500	--	--



Document Name	M101NWWB R3 Customer Approval Specification			Page 17 of 23	
Document No.	A-M101NWWB-R3-342-02	Made/Revised Date	2016/06/07	Ver.	01

## 5.0 Mechanical Characteristics

### 5.1 Outline Drawing

**Figure 12 Outline Drawing (Front Side)**

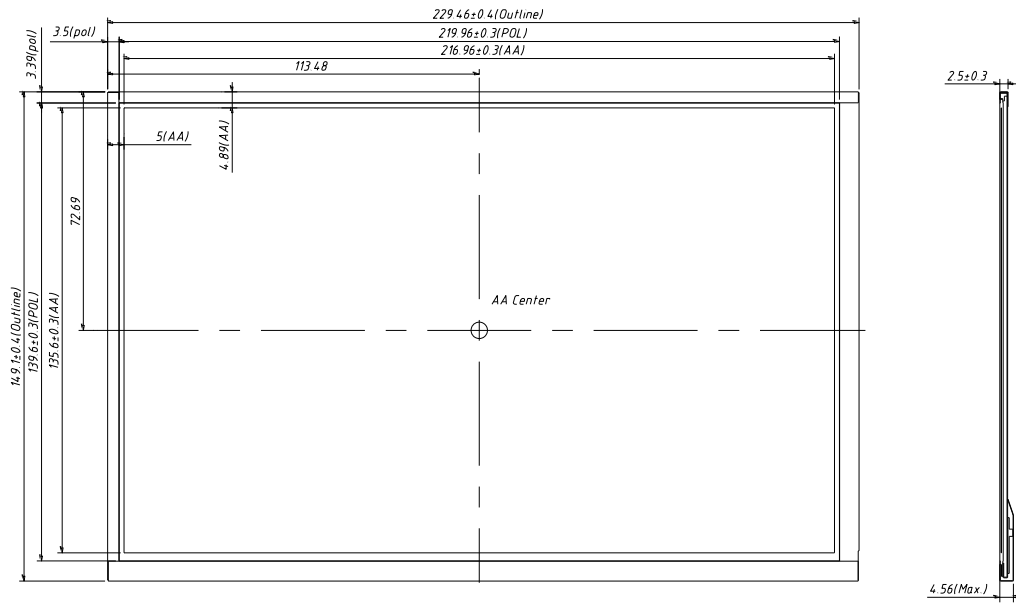

Document Name	M101NWWB R3 Customer Approval Specification			Page 18 of 23	
Document No.	A-M101NWWB-R3-342-02	Made/Revised Date	2016/06/07	Ver.	01

**Figure 13 Outline Drawing (Back Side)**

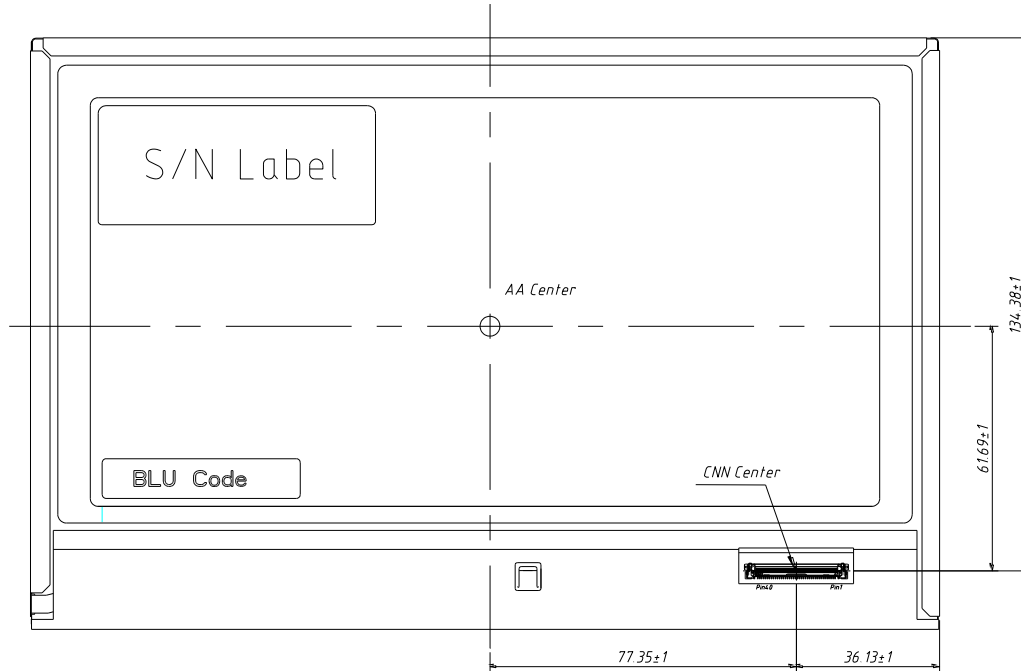

**5.2 Dimension Specifications**

**Table 9 Module Dimension Specifications**

Parameter	Min	Typ	Max	Unit
Width	229.06	229.46	229.86	mm
Height	148.7	149.1	149.5	mm
Depth w/o PCB	2.2	2.5	2.8	mm
Depth w/ PCB	-	-	4.56	mm
Weight	-	-	160	g



Document Name	M101NWWB R3 Customer Approval Specification			Page 19 of 23	
Document No.	A-M101NWWB-R3-342-02	Made/Revised Date	2016/06/07	Ver.	01

### 6.0 Reliability Conditions

Item	Package	Test Conditions	Note
High Temperature Operating Test	Module	70°C, 240 hours	(1),(2),(3),(4)
Low Temperature Operating Test	Module	-20°C, 240 hours	(1),(2),(3),(4)
High Temperature Storage Test	Module	80°C, 240 hours	(1),(2),(4)
Low Temperature Storage Test	Module	-30°C, 240 hours	(1),(2),(4)
High Temperature/High Humidity Operating Test	Module	60°C, 90%RH, 240 hours	(1),(2),(3),(4)
Shock Non-operating Test	Module	240G, 2ms, 1time for ±x, ±y, ±z 6 directions	(4)
Vibration Non-operating Test	Module	1.5G , 10~500 Hz , x、 y、 z each axis/1hour.	(4)
ESD Test	Module	150pF/330ohm, air ±15KV, contact ±8KV	(5)

Note (1) All the judgments are under room temperature and the sample need to be static more than 2 hours in the room temperature before judge.

Note (2) During measurement, the condensation water or remains shall not be allowed.

Note (3) In operating test, the backlight voltage and current must be in speccfication.

Note (4) There is no display function issue occurred, all the cosmetic specification is judged before the reliability stress.

Note (5) In case of malfunction defect caused by ESD damage. If it would be recovered to normal state after resetting, it would be judge as pass.

Document Name	M101NWWB R3 Customer Approval Specification			Page 20 of 23	
Document No.	A-M101NWWB-R3-342-02	Made/Revised Date	2016/06/07	Ver.	01

## 7.0 Package Specification

**Figure 14 Packing Method**

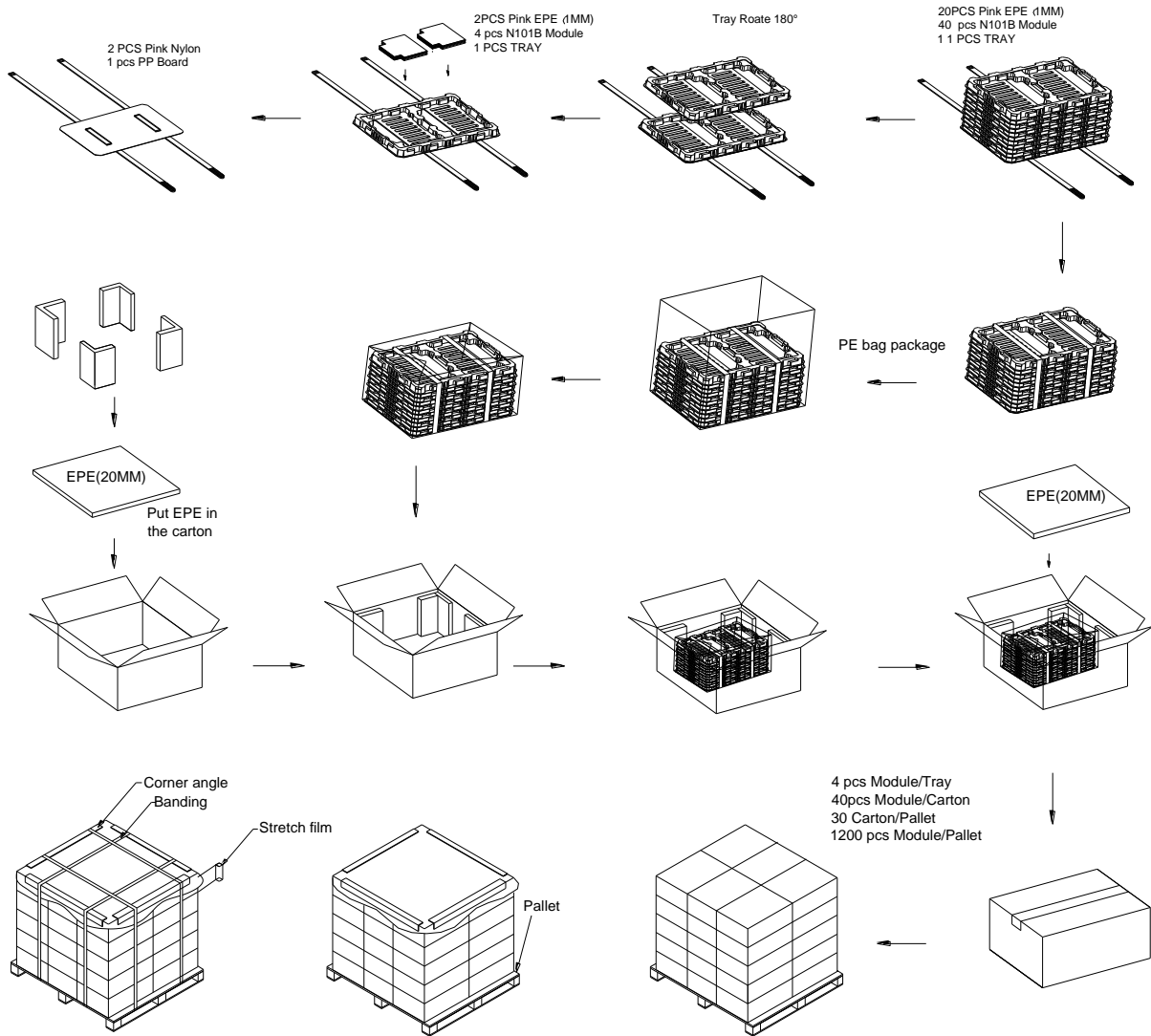

Document Name	M101NWWB R3 Customer Approval Specification			Page 21 of 23	
Document No.	A-M101NWWB-R3-342-02	Made/Revised Date	2016/06/07	Ver.	01

### 8.0 Lot Mark

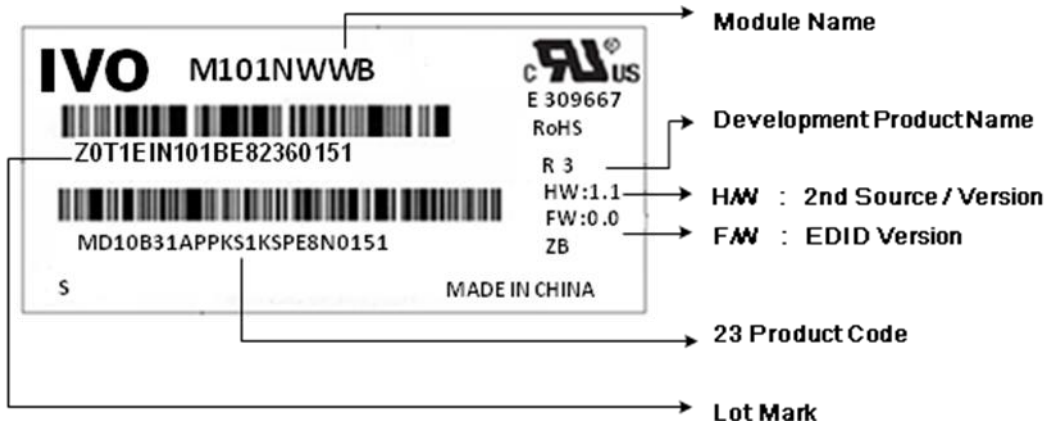

Note: This picture is only an example.

#### 8.1 20 Lot Mark

1	2	3	4	5	6	7	8	9	10	11	12	13	14	15	16	17	18	19	20
---	---	---	---	---	---	---	---	---	----	----	----	----	----	----	----	----	----	----	----

Code 1,2,4,5,6,7,8,9,10,11,16: IVO internal flow control code.

Code 3: Production Location.

Code 12: Production Year.

Code 13: Production Month.

Code 14,15: Production Day.

Code 17,18,19,20: Serial Number.

#### 8.2 23 Product Barcode

1	2	3	4	5	6	7	8	9	10	11	12	13	14	15	16	17	18	19	20	21	22	23
---	---	---	---	---	---	---	---	---	----	----	----	----	----	----	----	----	----	----	----	----	----	----

Code 1,2: Manufacture District.

Code 3,4,5,6,7: IVO internal module name.

Code 8,9,10,13,16: IVO internal flow control code.

Code 11,12: Cell location Suzhou, China defined as "KS".

Code 14,15: Module location Kunshan, China defined as "KS"; Yangzhou, China defined as "YZ"; Shenzhen, China defined as "SE"; Zhuhai, China defined as "ZH"; Suzhou, China defined as "SZ".

Code 17,18,19 : Year, Month, Day refer to Note(1), Note(2) and Note(3).

Note (1) Production Year

Year	2006	2007	2008	2009	2010	2011	2012	2013	.....	2035
Mark	6	7	8	9	A	B	C	D	.....	Z

Note (2) Production Month



Document Name	M101NWWB R3 Customer Approval Specification					Page 22 of 23	
Document No.	A-M101NWWB-R3-342-02	Made/Revised Date	2016/06/07	Ver.	01		

Month	Jan.	Feb.	Mar.	Apr.	May.	Jun.	Jul.	Aug.	Sep.	Oct	Nov.	Dec.
Mark	1	2	3	4	5	6	7	8	9	A	B	C

Note (3) Production Day: 1~V.  
Code 20~23 : Serial Number.

## 9.0 General Precaution

### 9.1 Use Restriction

This product is not authorized for use in life supporting systems, aircraft navigation control systems, military systems and any other application where performance failure could be life-threatening or otherwise catastrophic.

### 9.2 Handling Precaution

- (1) Please mount LCD module by using mounting holes arranged in four corners tightly.
- (2) Do not disassemble or modify the module. It may damage sensitive parts inside LCD module, and may cause scratches or dust on the display. IVO does not warrant the module, if customers disassemble or modify the module.
- (3) If LCD panel is broken and liquid crystal spills out, do not ingest or inhale liquid crystal, and do not contact liquid crystal with skin. If liquid crystal contacts mouth or eyes, rinse out with water immediately. If liquid crystal contacts skin or cloths, wash it off immediately with alcohol and rinse thoroughly with water.
- (4) Disconnect power supply before handling LCD module.
- (5) Refrain from strong mechanical shock and /or any force to the module.
- (6) Do not exceed the absolute maximum rating values, such as the supply voltage variation, input voltage variation, variation in parts parameters, environmental temperature; etc otherwise LCD module may be damaged. It's recommended employing protection circuit for power supply.
- (7) Do not touch, push or rub the polarizer with anything harder than HB pencil lead. Use fingerstalls of soft gloves in order to keep clean display quality, when persons handle the LCD module for incoming inspection or assembly.
- (8) When the surface is dusty, please wipe gently with absorbent cotton or other soft material. When cleaning the adhesives, please use absorbent cotton wetted with a little petroleum benzene or other adequate solvent.
- (9) Wipe off saliva or water drops as soon as possible. If saliva or water drops contact with polarizer for a long time, they may causes deformation or color fading.
- (10) Protection film must remove very slowly from the surface of LCD module to prevent from electrostatic occurrence.
- (11) Because LCD module uses CMOS-IC on circuit board and TFT-LCD panel, it is very weak to electrostatic discharge, please be careful with electrostatic discharge. Persons who handle the module should be grounded through adequate methods.
- (12) Do not adjust the variable resistor located on the module.

### 9.3 Storage Precaution

- (1) Please do not leave LCD module in the environment of high humidity and high temperature for a long time.
- (2) The module shall not be exposed under strong light such as direct sunlight. Otherwise, display characteristics may be changed.
- (3) The module should be stored in a dark place. It is prohibited to apply sunlight or fluorescent light in storage.

### 9.4 Operation Precaution



Document Name	M101NWWB R3 Customer Approval Specification			Page 23 of 23	
Document No.	A-M101NWWB-R3-342-02	Made/Revised Date	2016/06/07	Ver.	01

- (1) Do not connect or disconnect the module in the "Power On" condition.
- (2) Power supply should always be turned on/off by "Power On/Off Sequence".
- (3) Module has high frequency circuits. Sufficient suppression to the electromagnetic interference should be done by system manufacturers. Grounding and shielding methods may be important to minimize the interference.
- (4) After installation of the TFT module into an enclosure, do not twist nor bend the TFT module even momentary. At designing the enclosure, it should be taken into consideration that no bending/twisting forces are applied to the TFT module from outside. Otherwise the TFT module may be damaged.

**9.5 Others**

- (1) Ultra-violet ray filter is necessary for outdoor operation.
- (2) Avoid condensation of water which may result in improper operation or disconnection of electrode.
- (3) If the module keeps displaying the same pattern for a long period of time, the image may be "sticked" to the screen.
- (4) This module has its circuitry PCB's on the rear side and should be handled carefully in order not to be stressed.

**9.6 Disposal**

When disposing LCD module, obey the local environmental regulations.