



Document Title	M104GNX1 R1 Product Information			Page No.	1/26
Document No.		Issue date	2014/11/05	Revision	00

Product Information

To:

Product Name: M104GNX1 R1

Document Issue Date: 2014/11/05

Customer	InfoVision Optoelectronics
<p><u>SIGNATURE</u></p> <p>_____</p> <p>_____</p> <p>_____</p> <p>Please return 1 copy for your confirmation with your signature and comments.</p>	<p><u>SIGNATURE</u></p> <p>REVIEWED BY QA</p> <p>_____</p> <p>PREPARED BY FAE</p> <p>_____</p>

- Note: 1. Please contact InfoVision Company before designing your product based on this product.
 2. The information contained herein is presented merely to indicate the characteristics and performance of our products. No responsibility is assumed by IVO for any intellectual property claims or other problems that may result from application based on the module described herein.

FQ-7-30-0-009-03C



Document Title	M104GNX1 R1 Product Information			Page No.	2/26
Document No.		Issue date	2014/11/05	Revision	00

Revision	Date	Page	Old Description	New Description	Remark
00	2014/11/05	all	--	First issue.	

IVO Confidential document



Document Title	M104GNX1 R1 Product Information			Page No.	3/26
Document No.		Issue date	2014/11/05	Revision	00

CONTENTS

1.0	General Descriptions	4
2.0	Absolute Maximum Ratings	6
3.0	Optical Characteristics	7
4.0	Electrical Characteristics	10
5.0	Mechanical Characteristics	19
6.0	Reliability Conditions	22
7.0	Package Specification	23
8.0	Lot Mark.....	24
9.0	General Precaution.....	25

IVO Confidential document



Document Title	M104GNX1 R1 Product Information			Page No.	4/26
Document No.		Issue date	2014/11/05	Revision	00

1.0 General Descriptions

1.1 Introduction

The M104GNX1 R1 is a color active matrix thin film transistor (TFT) liquid crystal display (LCD) that uses amorphous silicon TFT as a switching device. This model is composed of a TFT LCD panel, a driver circuit and a backlight system. This TFT LCD has a 10.4 inch diagonally measured active display area with XGA resolution (1,024 horizontal by 768 vertical pixels array).

1.2 Features

- Supported XGA Resolution
- LVDS Interface
- Compatible with RoHS Standard

1.3 Product Summary

Items	Specifications	Unit
Screen Diagonal	10.4	inch
Active Area (H x V)	211.2 x 158.4	mm
Number of Pixels (H x V)	1,024 x 768	-
Pixel Pitch (H x V)	0.2063 x 0.2063	mm
Pixel Arrangement	R.G.B. Vertical Stripe	-
Display Mode	Normally White	-
White Luminance	350 (Typ.)	cd /m ²
Contrast Ratio	900 (Typ.)	-
Response Time	16 (Typ.)	ms
Input Voltage	3.3 (Typ.)	V
Power Consumption	3.72 (Max.)	W
Weight	300 (Max.)	g
Outline Dimension (H x V x D)	236.0 (Typ.) x 176.9(Typ.) x 5.70 (Typ)	mm
Electrical Interface (Logic)	LVDS	-
Support Color	262 K/16.7 M	-
NTSC	50 (Typ.)	%
Viewing Direction	6 O'clock	-
Surface Treatment	Anti-Glare	-

Document Title	M104GNX1 R1 Product Information			Page No.	5/26
Document No.		Issue date	2014/11/05	Revision	00

1.4 Functional Block Diagram

Figure 1 shows the functional block diagram of the LCD module.

Figure 1 Block Diagram

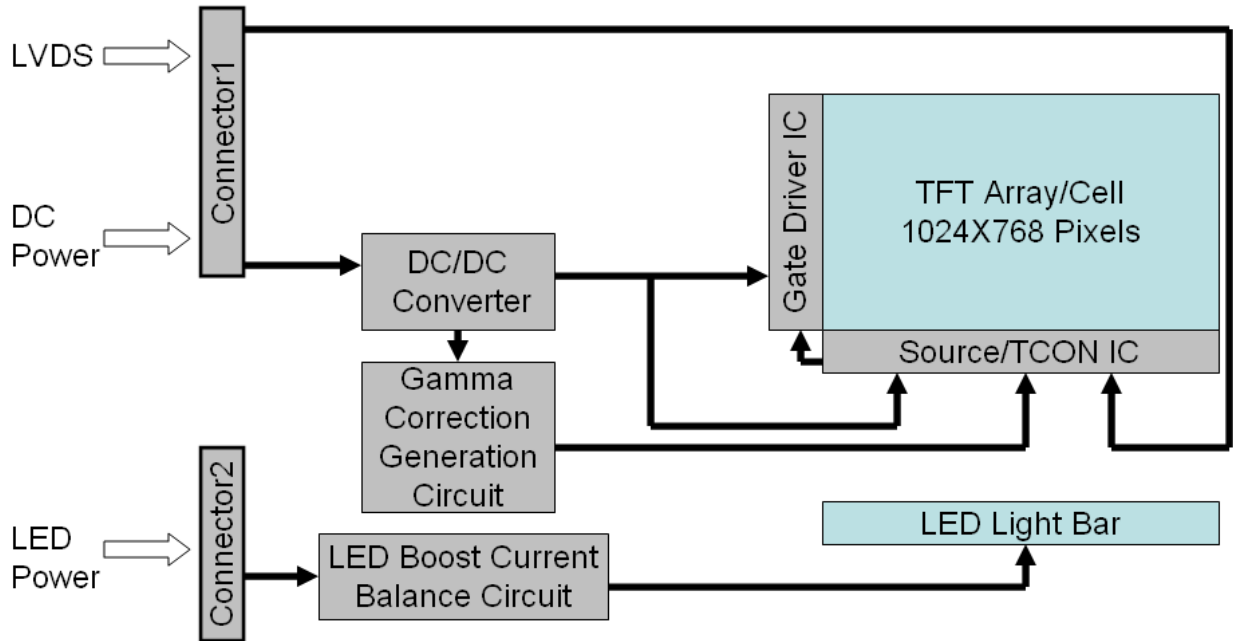

1.5 Pixel Mapping

Figure 2 Pixel Mapping

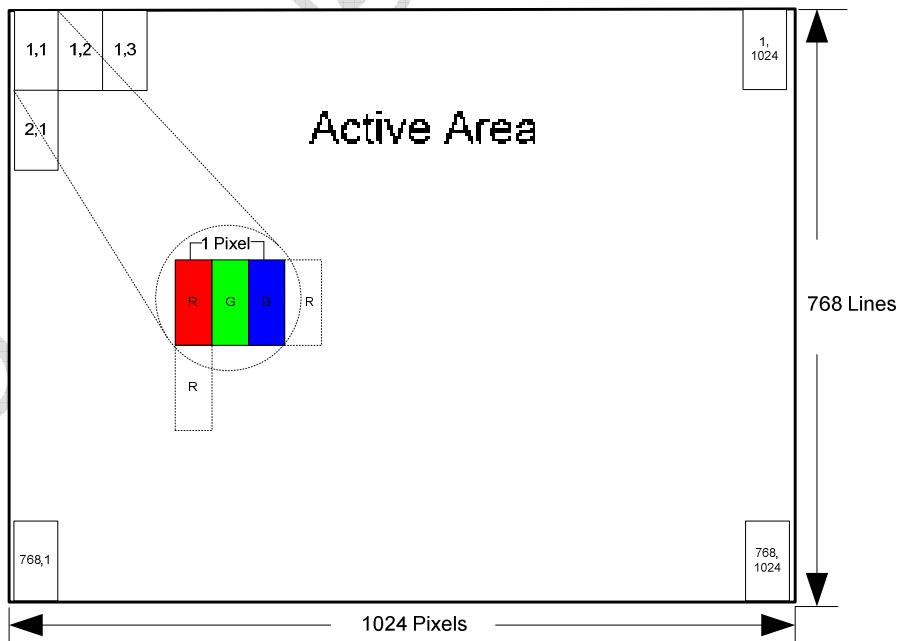

Document Title	M104GNX1 R1 Product Information			Page No.	6/26
Document No.		Issue date	2014/11/05	Revision	00

2.0 Absolute Maximum Ratings

Table 1 Electrical & Environment Absolute Rating

Item	Symbol	Min.	Max.	Unit	Note
Logic Supply Voltage	V _{DD}	-0.3	3.96	V	(1),(2)
LED Driver Voltage	V _{LDE}	-0.3	20	V	
Operating Temperature	T _{OP}	-20	70	°C	(3),(4),(5),(6)
Storage Temperature	T _{ST}	-30	80	°C	
Vibration(Non-operating)	VB	-	1.5	G	(7)
Shock(Non-operating)	Shock	-	100G	G	(8)

Note (1) Permanent damage may occur to the LCD module if beyond this specification. Functional operation should be restricted to the conditions described under normal operating conditions.

Note (2) Operating temperature 25°C, humidity 55%RH.

Note (3) (T≤40°C) Note static electricity.Maximum wet bulb temperature at 39°C or less. (T>40°C) No condensation.

Note (4) There is a possibility of causing deterioration in the irregularity and others of the screen and the display fineness though the liquid crystal module doesn't arrive at destruction when using it at 60~70°C or -20~0°C.

Note (5) There is a possibility of causing the fineness deterioration by the prolonged use in the (high temperature) humidity environment (60%RH or more).

Note (6) In the operating temperature item, the low temperature side is the ambient temperature regulations. The high temperature side is the panel surface temperature regulations.

Figure 3 Absolute Ratings of Environment of the LCD Module

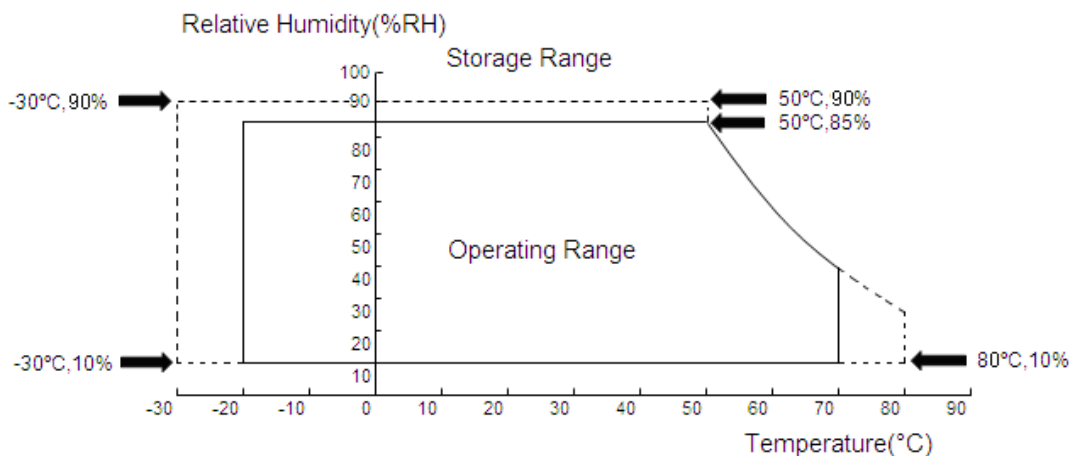

Note (7) 10-500Hz, random vibration, 30min for X, Y, Z axis.

Note (8) 2ms, half sine wave, one time for X, Y, Z axis.

Document Title	M104GNX1 R1 Product Information			Page No.	7/26
Document No.		Issue date	2014/11/05	Revision	00

3.0 Optical Characteristics

The optical characteristics are measured under stable conditions as following notes.

Table 2 Optical Characteristics

Item	Conditions		Min.	Typ.	Max.	Unit	Note		
Viewing Angle (CR>10)	Horizontal	θ_{x+}	70	75	-	degree	(1),(2),(3)		
		θ_{x-}	70	75	-				
	Vertical	θ_{y+}	70	75	-				
		θ_{y-}	70	75	-				
Contrast Ratio	Center		720	900	-	-	(1),(2),(4) $\theta_x=\theta_y=0^\circ$		
Response Time	Rising + Falling		-	16	25	ms	(1),(2),(5) $\theta_x=\theta_y=0^\circ$		
Color Chromaticity (CIE1931)	Red	x	Typ. -0.03	0.602	Typ. +0.03	-	(1),(2),(3) $\theta_x=\theta_y=0^\circ$		
	Red	y		0.352		-			
	Green	x		0.320		-			
	Green	y		0.570		-			
	Blue	x		0.155		-			
	Blue	y		0.132		-			
	White	x		0.260		0.310		0.360	-
	White	y		0.280		0.330		0.380	-
NTSC			48	50	-	%	(1),(2),(3) $\theta_x=\theta_y=0^\circ$		
White Luminance	Center		300	350	-	cd/m ²	(1),(2),(6) $\theta_x=\theta_y=0^\circ$		
Luminance Uniformity	9 Points		75	80	-	%	(1),(2),(7) $\theta_x=\theta_y=0^\circ$		

Note (1) Measurement Setup:

The LCD module should be stabilized at given temperature(25°C) for 15 minutes to avoid abrupt temperature change during measuring. In order to stabilize the luminance, the measurement should be executed after lighting backlight for 15 minutes in a windless room.

Document Title	M104GNX1 R1 Product Information			Page No.	8/26
Document No.		Issue date	2014/11/05	Revision	00

Figure 4 Measurement Setup

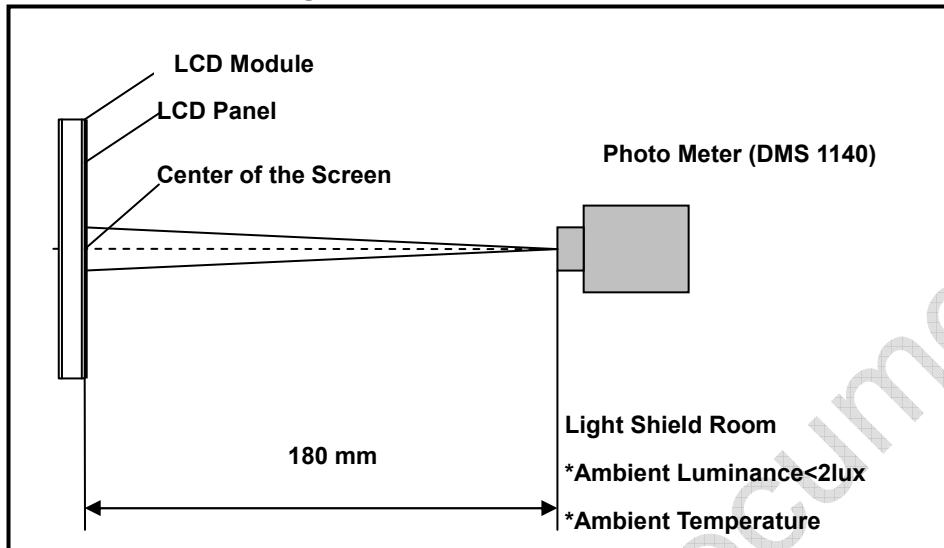

Note (2) The LED input parameter setting as:

I_{LED} : 80mA

PWM_LED: Duty 100 %

Note (3) Definition of Viewing Angle

Figure 5 Definition of Viewing Angle

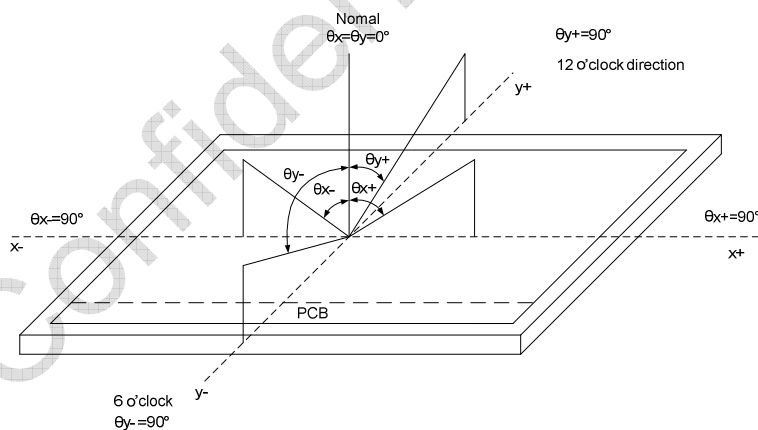

Note (4) Definition Of Contrast Ratio (CR)

The contrast ratio can be calculated by the following expression:

$$\text{Contrast Ratio (CR)} = L_{255} / L_0$$

L_{255} : Luminance of gray level 255, L_0 : Luminance of gray level 0

Note (5) Definition Of Response Time (T_R , T_F)

Document Title	M104GNX1 R1 Product Information			Page No.	9/26
Document No.		Issue date	2014/11/05	Revision	00

Figure 6 Definition of Response Time

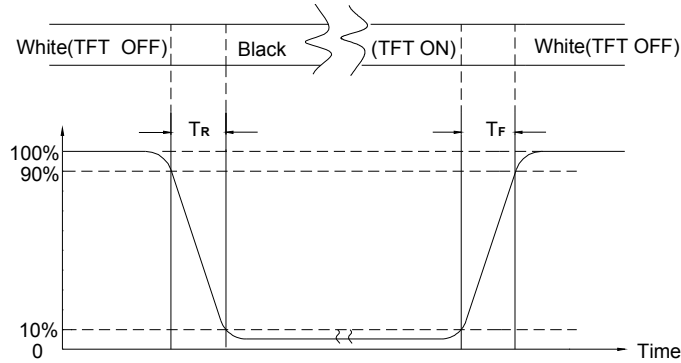

Note (6) Definition Of Luminance White

Measure the luminance of gray level 255 at center point (Ref.: Active Area)

Note (7) Definition Of Luminance Uniformity (Ref.: Active Area)

Measure the luminance of gray level 255 at 9 points.

Luminance Uniformity= $\text{Min.}(L1, L2, \dots L9) / \text{Max.}(L1, L2, \dots L9)$

H—Active Area Width, V—Active Area Height, L—Luminance

Figure 7 Measurement Locations of 9 Points

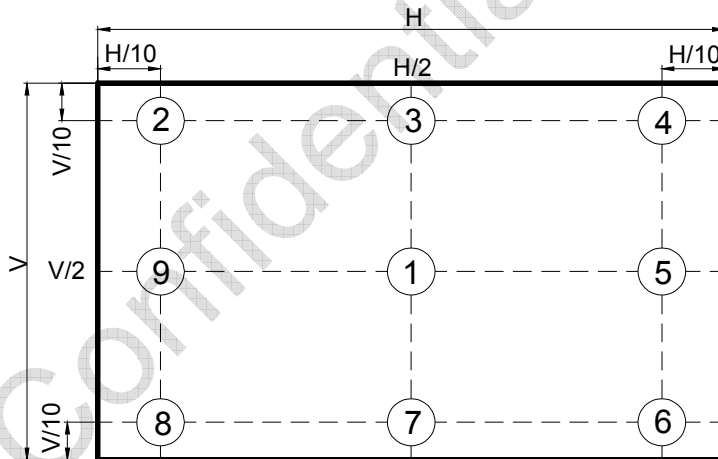

Document Title	M104GNX1 R1 Product Information			Page No.	10/26
Document No.		Issue date	2014/11/05	Revision	00

4.0 Electrical Characteristics

4.1 Interface Connector

Table 3 Signal Connector Type

Item	Description
Manufacturer / Type	STM/MSB24013P20HA
Mating Receptacle / Type (Reference)	P24013P20 or compatible

Table 4 Signal Connector Pin Assignment

Pin No.	Symbol	Description	Note
1	VDD	Power Supply, 3.3V (typical)	-
2	VDD	Power Supply, 3.3V (typical)	-
3	VSS	Ground	-
4	REV	Reverse Scan selection {High:2.5(min), 3.3(typ),3.6(max); Low: 0.5(max)}	(1)
5	Rin1-	-LVDS differential data input (R0-R5,G0)	-
6	Rin1+	+LVDS differential data input (R0-R5,G0)	-
7	VSS	Ground	-
8	Rin2-	-LVDS differential data input (G1-G5,B0-B1)	-
9	Rin2+	+LVDS differential data input (G1-G5,B0-B1)	-
10	VSS	Ground	-
11	Rin3-	-LVDS differential data input (B2-B5,HS,VS,DE)	-
12	Rin3+	+LVDS differential data input (B2-B5,HS,VS,DE)	-
13	VSS	Ground	-
14	ClkIN-	-LVDS differential clock input	-
15	ClkIN+	+LVDS differential clock input	-
16	GND	Ground	-
17	Rin4-	-LVDS differential data input (R6-R7,G6-G7,B6-B7)	-
18	Rin4+	+VDS differential data input (R6-R7,G6-G7,B6-B7)	-
19	SEL68	6/8 bits LVDS data input selection(H:8bits L/NC:6bits)	-
20	Bist	Internal use	-

Note(1) REV=LOW/NC

Document Title	M104GNX1 R1 Product Information			Page No.	11/26
Document No.		Issue date	2014/11/05	Revision	00

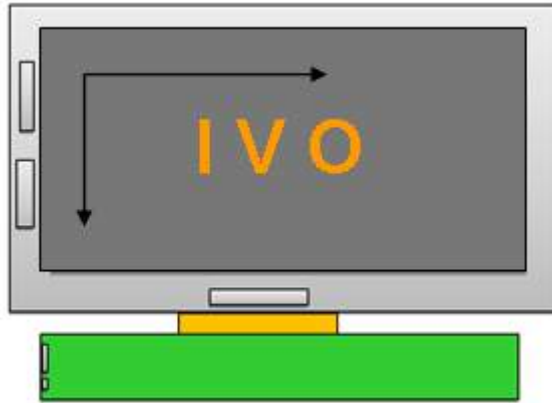

REV = High

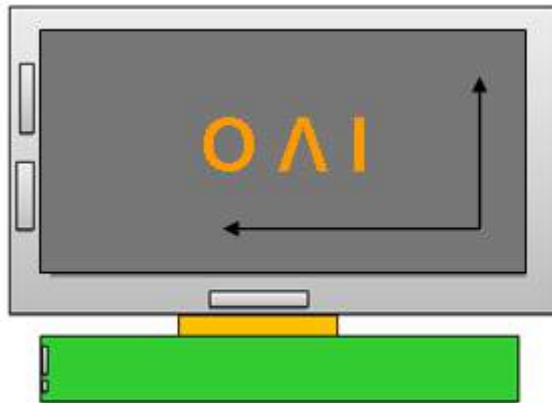

Table 5 LED Connector Name / Designation

Item	Description
Manufacturer / Type	STM/MSB24038P5A
Mating Receptacle / Type (Reference)	P24038P5

Table 6 LED Connector Pin Assignment

Pin No.	Symbol	Signal name
1	VCC	12V
2	GND	GND
3	ON/OFF	5V-ON,0V-OFF
4	Dimming	PWM Dimming or Analog Dimming
5	NC	NC

Document Title	M104GNX1 R1 Product Information			Page No.	12/26
Document No.		Issue date	2014/11/05	Revision	00

4.2 Signal Electrical Characteristics

4.2.1 Signal Electrical Characteristics For LVDS Receiver

The built-in LVDS receiver is compatible with (ANSI/TIA/TIA-644) standard.

Table 7 LVDS Receiver Electrical Characteristics

Parameter	Symbol	Min.	Typ.	Max.	Unit	Conditions
Differential Input High Threshold	V _{th}	-	-	+100	mV	V _{CM} =+1.2V
Differential Input Low Threshold	V _{tl}	-100	-	-	mV	V _{CM} =+1.2V
Magnitude Differential Input Voltage	V _{ID}	200	-	600	mV	-
Common Mode Voltage	V _{CM}	1.0	1.2	1.4	V	V _{th} – V _{tl} =200 mV
Common Mode Voltage Offset	ΔV _{CM}	-50	-	50	mV	V _{th} – V _{tl} =200 mV

Note (1) Input signals shall be low or Hi- resistance state when VDD is off.

Note (2) All electrical characteristics for LVDS signal are defined and shall be measured at the interface connector of LCD.

Figure 8 Voltage Definitions

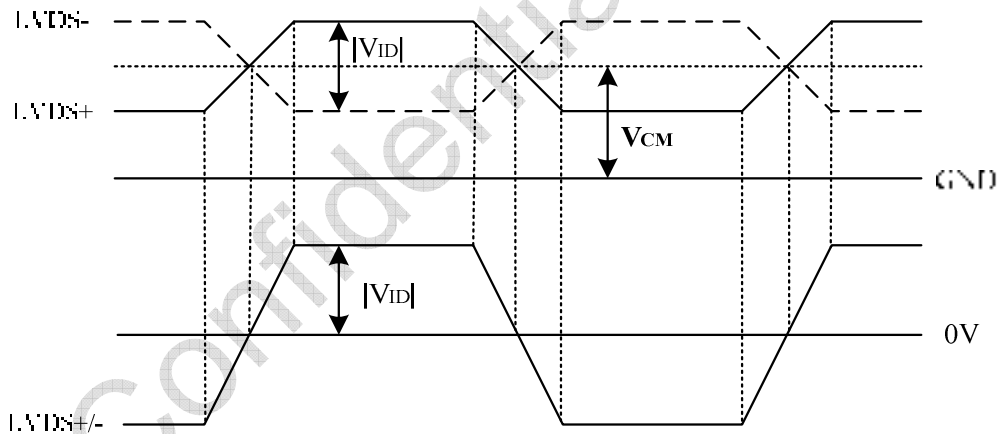

Document Title	M104GNX1 R1 Product Information			Page No.	13/26
Document No.		Issue date	2014/11/05	Revision	00

Figure 9 Measurement System

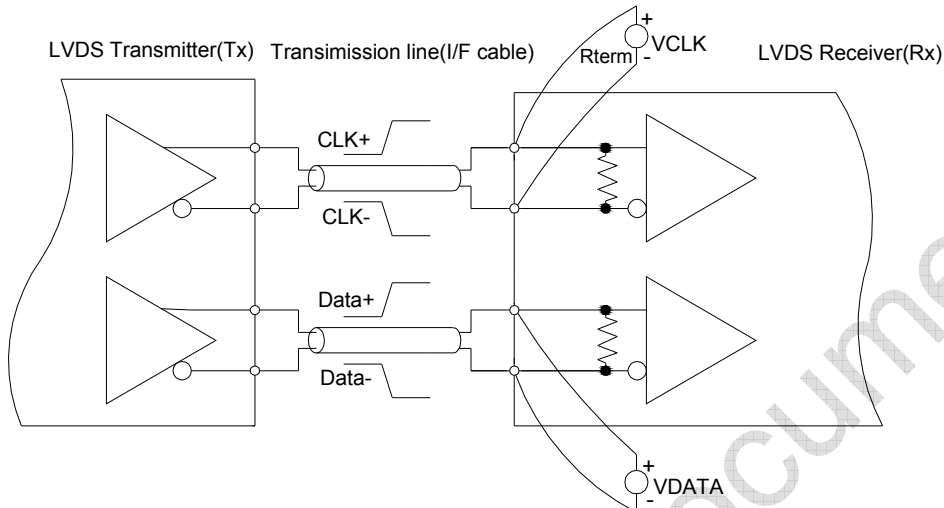

Figure 10 Data Mapping (6 Bit)

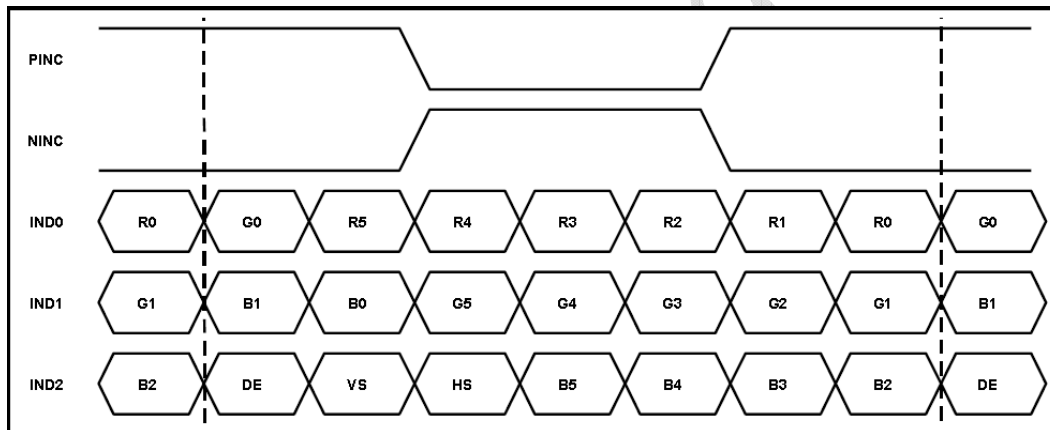
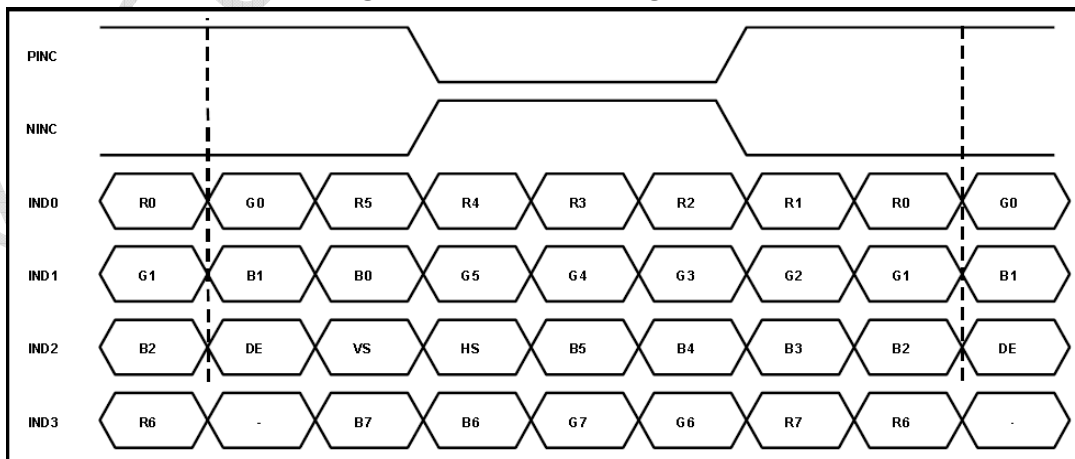

Figure 11 Data Mapping (8 Bit)



Document Title	M104GNX1 R1 Product Information			Page No.	14/26
Document No.		Issue date	2014/11/05	Revision	00

4.2.2 LVDS Receiver Internal Circuit

Figure 12 LVDS Receiver Internal Circuit shows the internal block diagram of the LVDS receiver. This LCD module equips termination resistors for LVDS link.

Figure 12 LVDS Receiver Internal Circuit

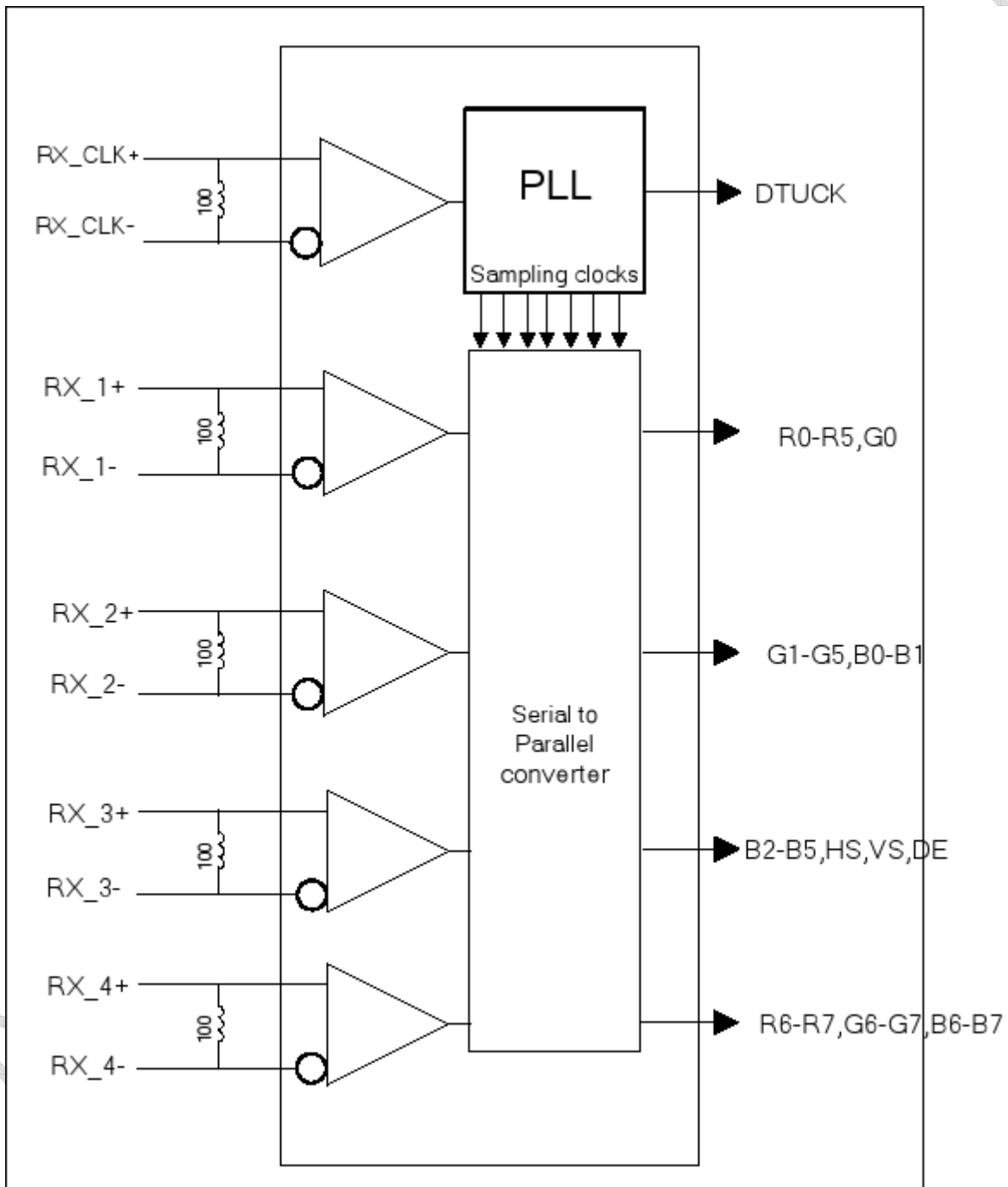



Document Title	M104GNX1 R1 Product Information			Page No.	15/26
Document No.		Issue date	2014/11/05	Revision	00

4.3 Interface Timings

Table 8 Interface Timings

Parameter	Symbol	Min.	Typ.	Max.	Unit
LVDS Clock Frequency	Fclk	52	65	71	MHz
H Total Time	HT	1,114	1,344	1,400	Clocks
H Active Time	HA	1,024	1,024	1,024	Clocks
V Total Time	VT	778	806	845	Lines
V Active Time	VA	768	768	768	Lines
Frame Rate	FV	55	60	65	Hz

Document Title	M104GNX1 R1 Product Information			Page No.	16/26
Document No.		Issue date	2014/11/05	Revision	00

4.4 Input Power Specifications

Input power specifications are as follows.

Table 9 Input Power Specifications

Parameter	Symbol	Min.	Typ.	Max.	Unit	Note	
System Power Supply							
LCD Drive Voltage (Logic)	V_{DD}	3.0	3.3	3.6	V	(2), (4)	
VDD Current	Black Pattern	I_{DD}	-	-	0.25	A	(3),(4)
VDD Power Consumption	Black Pattern	P_{DD}	-	-	0.84	W	
Rush Current	I_{Rush}	-	-	1.5	A	(1),(4),(5)	
Allowable Logic/LCD Drive Ripple Voltage	V_{VDD-RP}	-	-	200	mV	(4)	
LED Power Supply							
LED Input Voltage	V_{LED}	10.8	12	12.6	V	(4)	
LED Power Consumption	P_{LED}	-	-	2.88	W	(4),	
LED Forward Voltage	V_F	2.8	3.2	3.6	V	(4)	
LED Forward Current	I_F	-	20	30	mA		
PWM Signal Voltage	High	V_{PWM}	4.5	5	5.5		V
	Low		0	-	0.4		
LED Enable Voltage	High	V_{LED_EN}	2.0	5	5.5		V
	Low		0	-	0.4		
Input PWM Frequency	F_{PWM}	100	-	1K	Hz		
Duty Ratio	PWM	5	-	100	%		
LED Life Time	LT	30,000	-	-	Hours		(4)(6)

Note (1) Measure Condition

Figure 13 VDD Rising Time

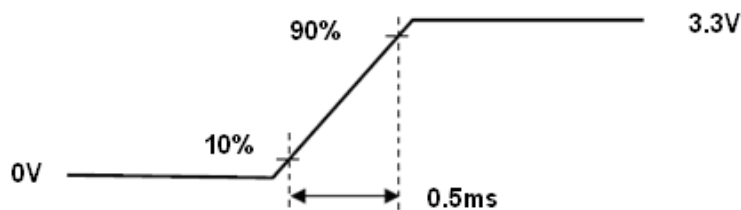

Note (2) VDD Power Dip Condition

Document Title	M104GNX1 R1 Product Information			Page No.	17/26
Document No.		Issue date	2014/11/05	Revision	00

$V_{TH} < V_{DD} \leq V_{min}$, $t_d \leq 10ms$ (a time of the voltage return to normal), our panel can revive automatically.

Figure 14 VDD Power Dip

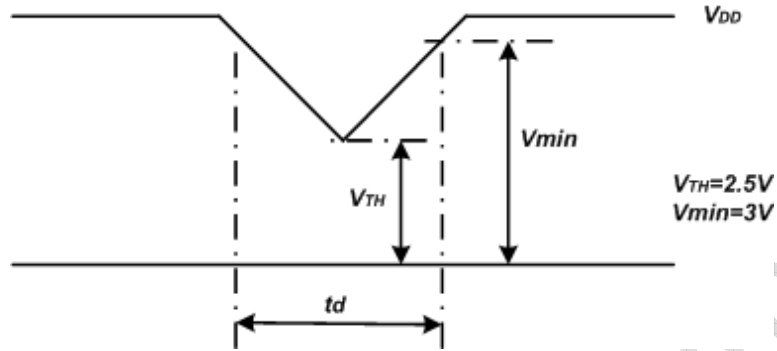

Note (3) Frame Rate=60Hz, VDD=3.3V, DC Current.

Note (4) Operating temperature 25°C, humidity 55%RH.

Note (5) The reference measurement circuit of rush current.

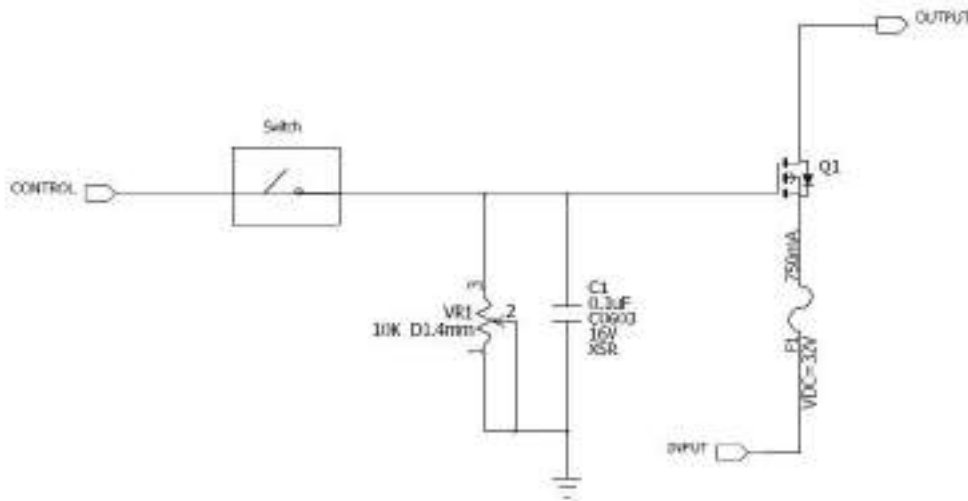

Note (6) The LED life time define as the estimated time to 50% degradation of initial luminous.

Document Title	M104GNX1 R1 Product Information			Page No.	18/26
Document No.		Issue date	2014/11/05	Revision	00

4.5 Power ON/OFF Sequence

Interface signals are also shown in the chart. Signals from any system shall be Hi- resistance state or low level when VDD voltage is off.

Figure 15 Power Sequence

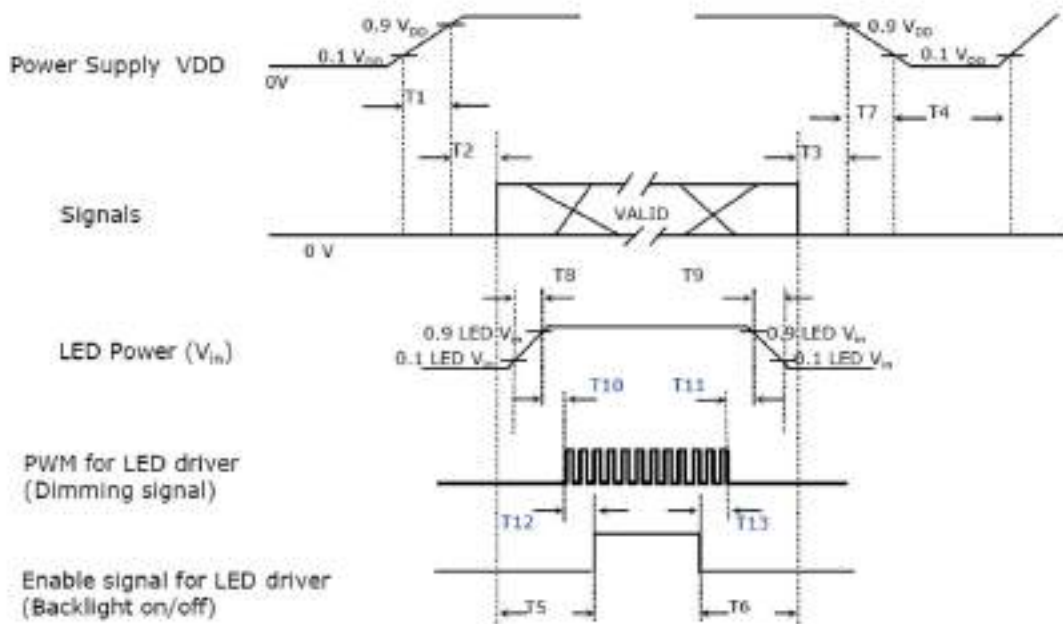

Table 10 Power Sequencing Requirements

Parameter	Symbol	Min.	Typ.	Max.	Unit
VDD rising time from 10% to 90%	T1	0.5	-	10	ms
Delay from VDD to valid data at power ON	T2	30	-	50	ms
Delay from valid data OFF to VDD OFF at power OFF	T3	0	-	50	ms
VDD OFF time for windows restart	T4	500	-	-	ms
Delay from valid data to B/L enable at power ON	T5	200	-	-	ms
Delay from valid data off to B/L disable at power Off	T6	200	-	-	ms
VDD falling time from 90% to 10%	T7	0.5	-	10	ms
LED Vin rising time from 10% to 90%	T8	0.5	-	10	ms
LED Vin falling time from 90% to 10%	T9	0.5	-	10	ms
Delay from LED driver Vin rising time 90% to PWM ON	T10	0	-	-	ms
Delay from PWM Off to LED driver Vin falling time 10%,Must keep rule	T11	0	-	-	ms
Delay from PWM ON to B/L Enable ON, Must keep rule	T12	0	-	-	ms
Delay from B/L Enable Off to PWM Off	T13	0	-	-	ms

Document Title	M104GNX1 R1 Product Information			Page No.	19/26
Document No.		Issue date	2014/11/05	Revision	00

5.0 Mechanical Characteristics

5.1 Outline Drawing

Figure 16 Reference Outline Drawing (Front Side)

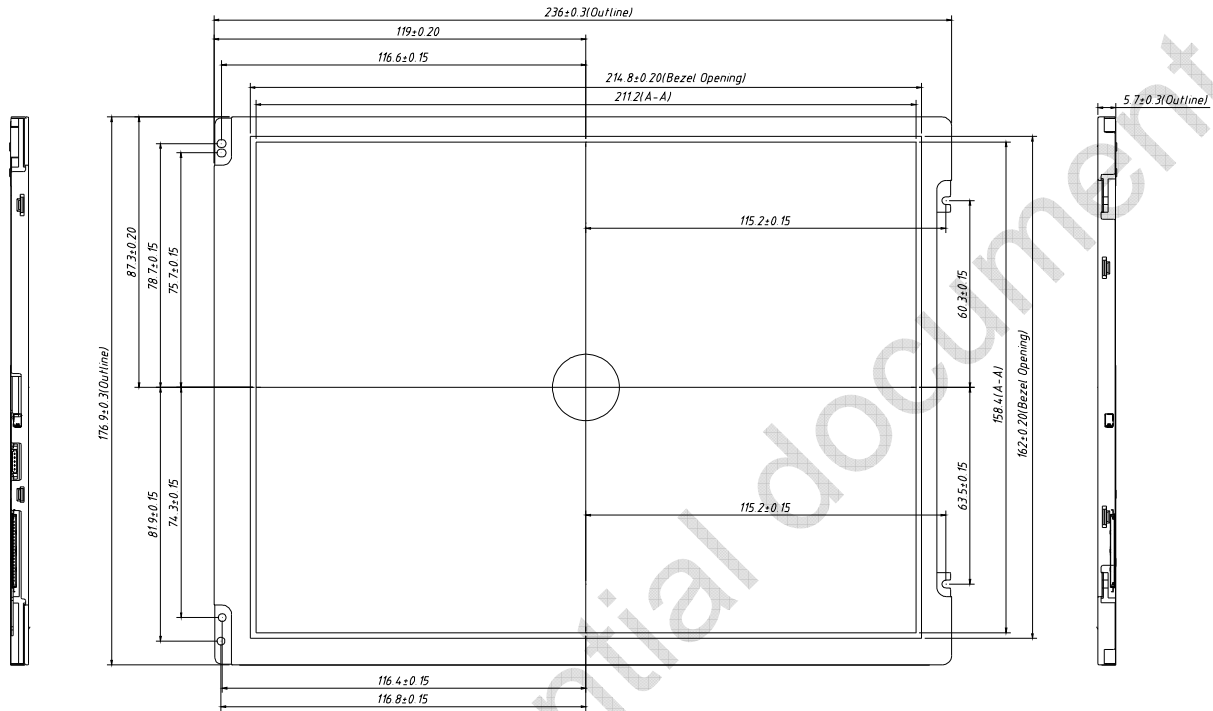



昆山龙腾光电有限公司

InfoVision Optoelectronics (Kunshan) Co.,LTD.

Document Title	M104GNX1 R1 Product Information			Page No.	20/26
Document No.		Issue date	2014/11/05	Revision	00

Figure 17 Reference Outline Drawing (Back Side)



Document Title	M104GNX1 R1 Product Information			Page No.	21/26
Document No.		Issue date	2014/11/05	Revision	00

5.2 Dimension Specifications

Table 11 Module Dimension Specifications

Item	Min.	Typ.	Max.	Unit
Width	235.7	236.0	236.3	mm
Height	176.6	176.9	177.2	mm
Thickness	5.4	5.7	6.0	mm
Weight	-	-	300	g
BM : a-b & c-d	≤ 1.0			mm

Figure 18 BM Area

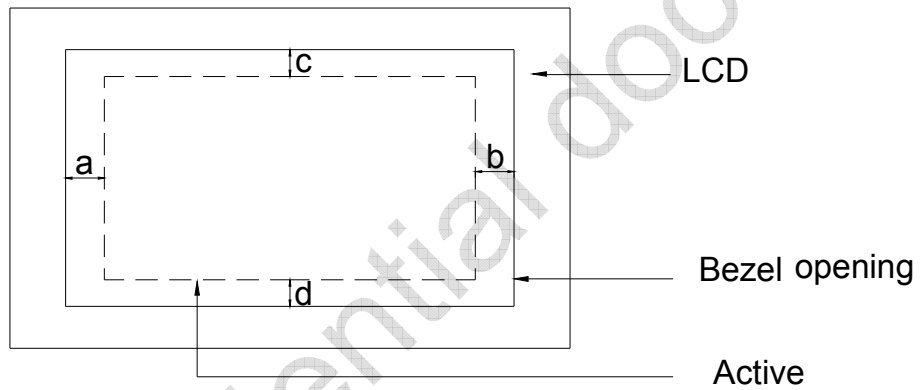



Document Title	M104GNX1 R1 Product Information			Page No.	22/26
Document No.		Issue date	2014/11/05	Revision	00

6.0 Reliability Conditions

Item		Package	Test Conditions		Note
High Temperature Operating Test		Module	70°C, 240 hours		(1),(2),(3),(4)
Low Temperature Operating Test		Module	-20°C, 240 hours		(1),(2),(3),(4)
High Temperature Storage Test		Module	80°C, 240 hours		(1),(2),(4)
Low Temperature Storage Test		Module	-30°C, 240 hours		(1),(2),(4)
High Temperature/High Humidity Storage Test		Module	50°C, 90%RH, 240 hours		(1),(2),(4)
High Temperature/High Humidity Operating Test		Module	50°C, 85%RH, 240 hours		(1),(2),(3),(4)
Shock Non-operating Test		Module	3 shock in each direction Peak acceleration:981m/s ² Half Sine Wave; 6ms.		(4)
Vibration Non-operating Test		Module	1.5G , 10~500 Hz , x、 y、 z each axis/1hour.		(4)
ESD Test	Operating	Module	Contact	± 8 KV, 150pF(330Ohm)	(5)
			Air	± 15 KV, 150pF(330Ohm)	
	Contact		± 10 KV, 150pF(330Ohm)		
	Air		± 20 KV, 150pF(330Ohm)		
Non-operating					

Note (1) All the judgments are under room temperature and the sample need to be static more than 2 hours in the room temperature before judge.

Note (2) During measurement, the condensation water or remains shall not be allowed.

Note (3) In operating test, the backlight voltage and current must be in speccfication.

Note (4) There is no display function issue occurred, all the cosmetic specification is judged before the reliability stress.

Note (5) In case of malfunction defect caused by ESD damage. If it would be recovered to normal state after resetting, it would be judge as pass.

Document Title	M104GNX1 R1 Product Information			Page No.	23/26
Document No.		Issue date	2014/11/05	Revision	00

7.0 Package Specification

Figure 19 Packing Method

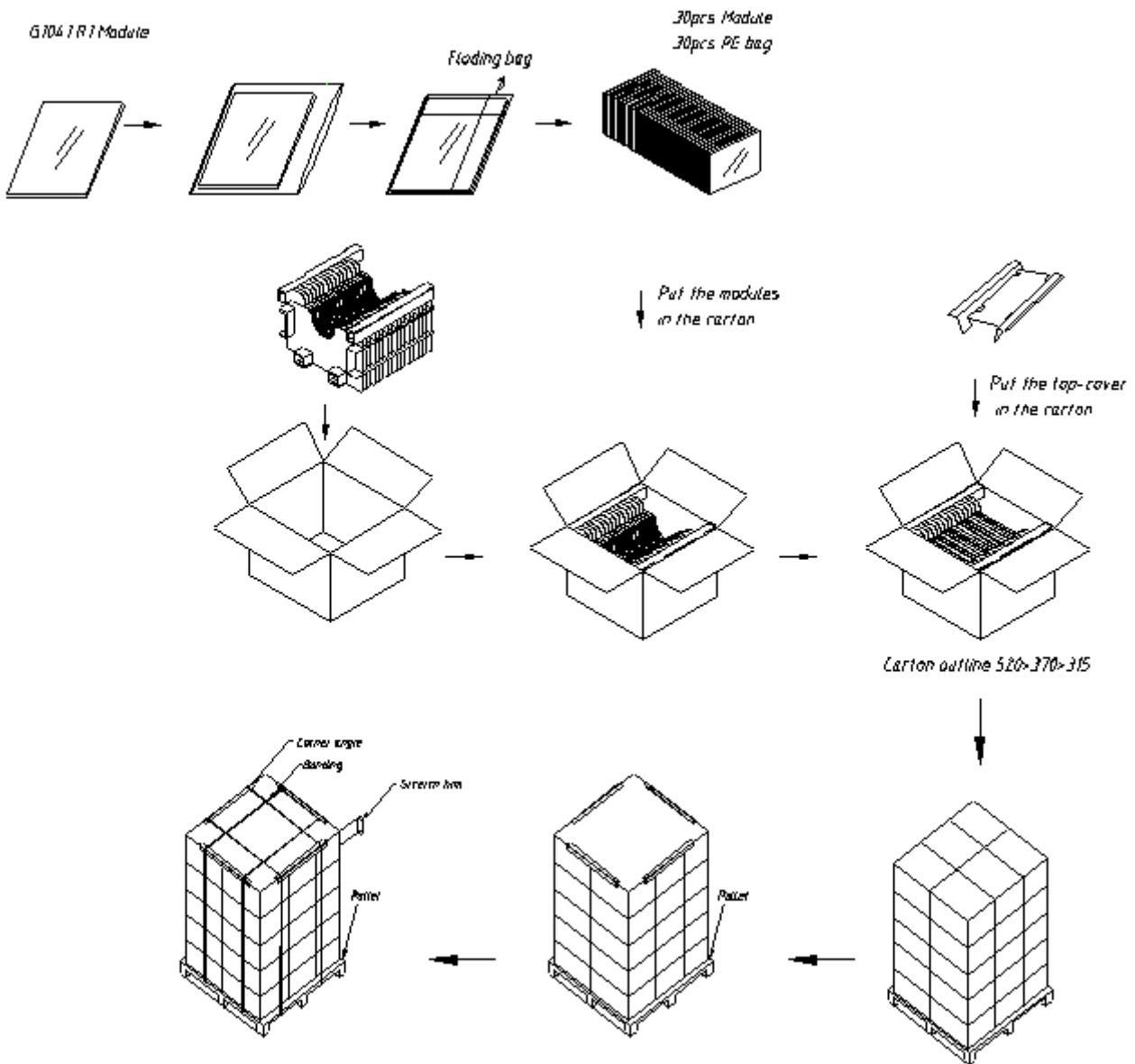



Document Title	M104GNX1 R1 Product Information			Page No.	24/26
Document No.		Issue date	2014/11/05	Revision	00

8.0 Lot Mark

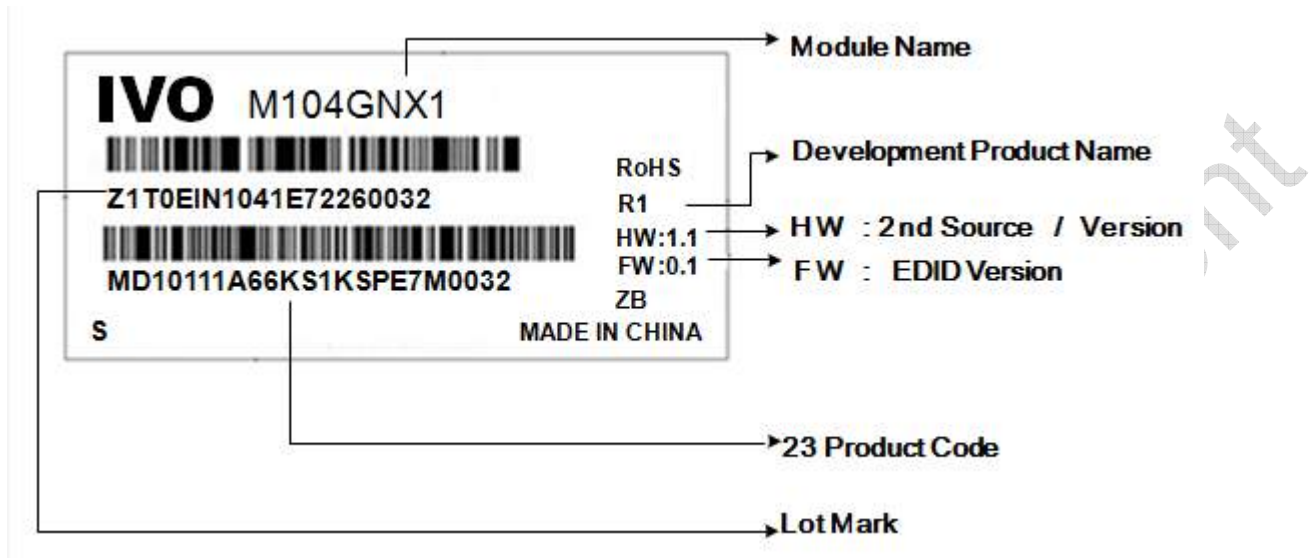

Note: This picture is only an example.

8.1 20 Lot Mark

1	2	3	4	5	6	7	8	9	10	11	12	13	14	15	16	17	18	19	20
---	---	---	---	---	---	---	---	---	----	----	----	----	----	----	----	----	----	----	----

Code 1,2,4,5,6,7,8,9,10,11,16: IVO internal flow control code.

Code 3: Production Location.

Code 12: Production Year.

Code 13: Production Month.

Code 14,15: Production Day.

Code 17,18,19,20: Serial Number.

8.2 23 Product Barcode

1	2	3	4	5	6	7	8	9	10	11	12	13	14	15	16	17	18	19	20	21	22	23
---	---	---	---	---	---	---	---	---	----	----	----	----	----	----	----	----	----	----	----	----	----	----

Code 1,2: Manufacture District.

Code 3,4,5,6,7: IVO internal module name.

Code 8,9,10,13,16: IVO internal flow control code.

Code 11,12: Cell location Suzhou, China defined as "KS".

Code 14,15: Module location Kunshan, China defined as "KS"; Yangzhou, China defined as "YZ"; Shenzhen, China defined as "SE"; Zhuhai, China defined as "ZH"; Suzhou, China defined as "SZ".

Code 17,18,19 : Year, Month, Day refer to Note(1), Note(2) and Note(3).

Note (1) Production Year

Year	2006	2007	2008	2009	2010	2011	2012	2013	2035
Mark	6	7	8	9	A	B	C	D	Z



Document Title	M104GNX1 R1 Product Information			Page No.	25/26
Document No.		Issue date	2014/11/05	Revision	00

Note (2) Production Month

Month	Jan.	Feb.	Mar.	Apr.	May.	Jun.	Jul.	Aug.	Sep.	Oct	Nov.	Dec.
Mark	1	2	3	4	5	6	7	8	9	A	B	C

Note (3) Production Day: 1~V.

Code 20~23 : Serial Number.

9.0 General Precaution

9.1 Use Restriction

This product is not authorized for use in life supporting systems, aircraft navigation control systems, military systems and any other application where performance failure could be life-threatening or otherwise catastrophic.

9.2 Handling Precaution

- (1) Please mount LCD module by using mounting holes arranged in four corners tightly.
- (2) Do not disassemble or modify the module. It may damage sensitive parts inside LCD module, and may cause scratches or dust on the display. IVO does not warrant the module, if customers disassemble or modify the module.
- (3) If LCD panel is broken and liquid crystal spills out, do not ingest or inhale liquid crystal, and do not contact liquid crystal with skin. If liquid crystal contacts mouth or eyes, rinse out with water immediately. If liquid crystal contacts skin or cloths, wash it off immediately with alcohol and rinse thoroughly with water.
- (4) Disconnect power supply before handling LCD module.
- (5) Refrain from strong mechanical shock and /or any force to the module.
- (6) Do not exceed the absolute maximum rating values, such as the supply voltage variation, input voltage variation, variation in parts parameters, environmental temperature; etc otherwise LCD module may be damaged. It's recommended employing protection circuit for power supply.
- (7) Do not touch, push or rub the polarizer with anything harder than HB pencil lead. Use fingerstalls of soft gloves in order to keep clean display quality, when persons handle the LCD module for incoming inspection or assembly.
- (8) When the surface is dusty, please wipe gently with absorbent cotton or other soft material. When cleaning the adhesives, please use absorbent cotton wetted with a little petroleum benzene or other adequate solvent.
- (9) Wipe off saliva or water drops as soon as possible. If saliva or water drops contact with polarizer for a long time, they may causes deformation or color fading.
- (10) Protection film must remove very slowly from the surface of LCD module to prevent from electrostatic occurrence.
- (11) Because LCD module uses CMOS-IC on circuit board and TFT-LCD panel, it is very weak to electrostatic discharge, please be careful with electrostatic discharge. Persons who handle the module should be grounded through adequate methods.
- (12) Do not adjust the variable resistor located on the module.

9.3 Storage Precaution

- (1) Please do not leave LCD module in the environment of high humidity and high temperature for a long time.
- (2) The module shall not be exposed under strong light such as direct sunlight. Otherwise, display characteristics may be changed.
- (3) The module should be stored in a dark place. It is prohibited to apply sunlight or fluorescent light in storage.



Document Title	M104GNX1 R1 Product Information			Page No.	26/26
Document No.		Issue date	2014/11/05	Revision	00

9.4 Operation Precaution

- (1) Do not connect or disconnect the module in the "Power On" condition.
- (2) Power supply should always be turned on/off by "Power On/Off Sequence".
- (3) Module has high frequency circuits. Sufficient suppression to the electromagnetic interference should be done by system manufacturers. Grounding and shielding methods may be important to minimize the interference.
- (4) After installation of the TFT module into an enclosure, do not twist nor bend the TFT module even momentary. At designing the enclosure, it should be taken into consideration that no bending/twisting forces are applied to the TFT module from outside. Otherwise the TFT module may be damaged.

9.5 Others

- (1) Ultra-violet ray filter is necessary for outdoor operation.
- (2) Avoid condensation of water which may result in improper operation or disconnection of electrode.
- (3) If the module keeps displaying the same pattern for a long period of time, the image may be "sticked" to the screen.
- (4) This module has its circuitry PCB's on the rear side and should be handled carefully in order not to be stressed.

9.6 Disposal

When disposing LCD module, obey the local environmental regulations.