



Document Title	M150GNN2 R1 Tentative Product Information	Page No.	2/20		
Document No.		Issue Date	2013/02/05	Revision	V00

Contents

1.0 General Descriptions Introduction	3
2.0 Absolute Maximum Ratings	5
3.0 Pixel Format Image	6
4.0 Optical Characteristics	7
5.0 Backlight Characteristics	10
6.0 Electrical Characteristics	11
7.0 Interface Timings	14
8.0 Power Consumption	15
9.0 Power ON/OFF Sequence	16
10.0 Mechanical Characteristics	17
11.0 Package Specification	18
12.0 General Precaution	19



Document Title	M150GNN2 R1 Tentative Product Information	Page No.	3/20		
Document No.		Issue Date	2013/02/05	Revision	V00

1.0 General Descriptions Introduction

1.1 Introduction

The M150GNN2 is a color active matrix thin film transistor (TFT) liquid crystal display (LCD) that uses amorphous silicon TFT as a switching device. It is composed of a TFT LCD panel, a backlight system, column driver and row driver circuit. This TFT LCD has a 15.0-inch diagonally measured active display area with resolution (1024 horizontal by 768 vertical pixels array).

1.2 Features

- 15.0" TFT LCD Panel
- LED Backlight System
- Supported 1024x768 pixels resolution
- Compatible with RoHS standard

1.3 Product Summary

Items	Specifications	Unit
Screen Diagonal	15.0	Inch
Active Area	304.128(H) x 228.096(V)	mm
Pixels H x V	1024(RGB) x768	-
Pixel Pitch	0.297(H) x 0.297(V)	mm
Pixel Arrangement	R.G.B. Vertical Stripe	-
Display Mode	Normally White	-
White Luminance	350(Typ)	cd /m ²
Contrast Ratio	800 : 1 (Typ) 450 : 1 (Min)	-
Response Time	16	msec
Input Voltage	3.3	V
Weight	930(Typ.) 960 (Max)	g
Outline Dimension	326.5(H) x 253.5(V) x12(D) Typ.	mm
Electrical Interface (Logic)	LVDS	-
Support Color	16.2M	-
Surface Treatment	Anti-glare, Hard-Coating (3H)	-

Document Title	M150GNN2 R1 Tentative Product Information		Page No.	4/20
Document No.		Issue Date	2013/02/05	Revision
				V00

1.4 Functional Block Diagram

Shows the functional block diagram of the LCD module.

Figure 1 Block Diagram

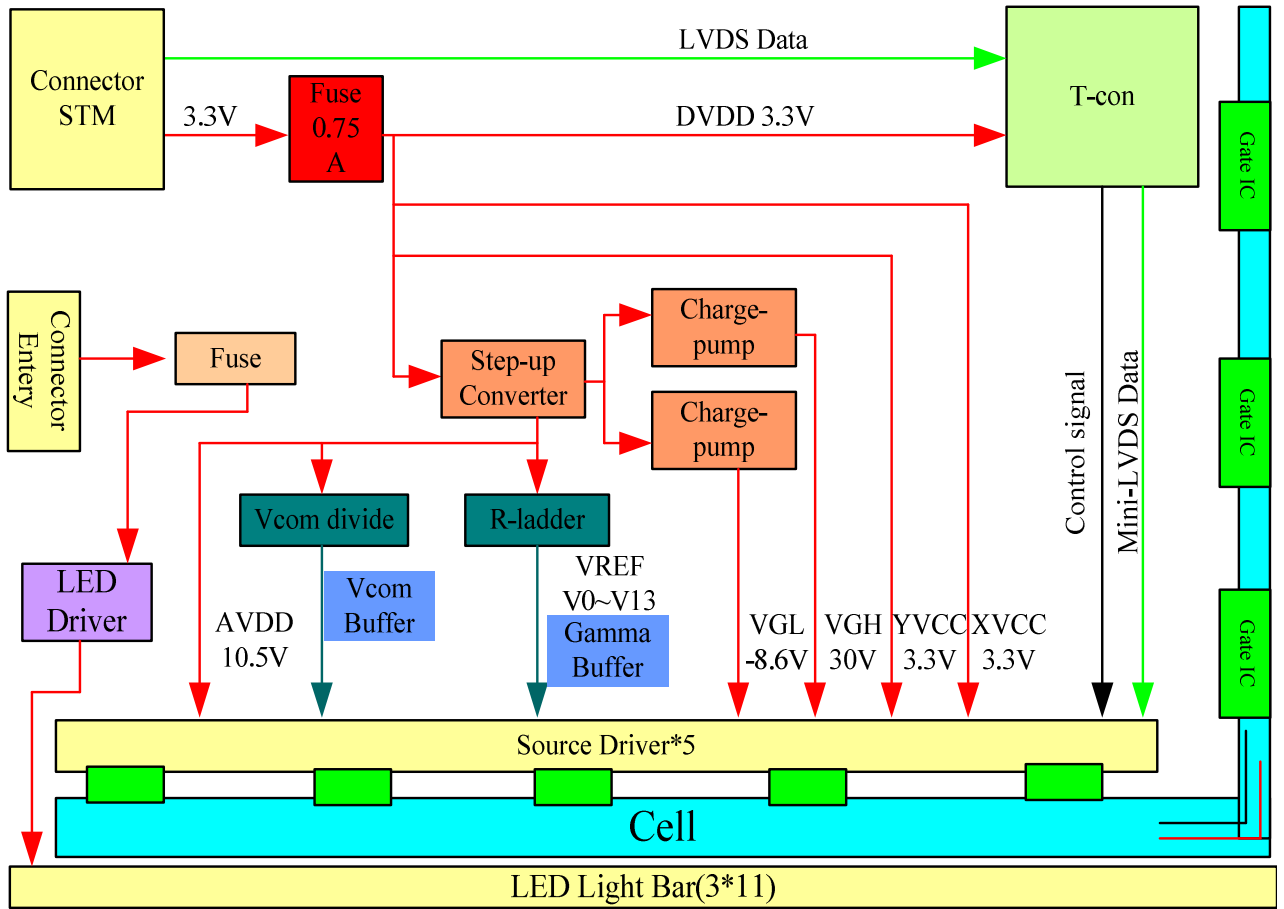



Document Title	M150GNN2 R1 Tentative Product Information		Page No.	5/20	
Document No.		Issue Date	2013/02/05	Revision	V00

2.0 Absolute Maximum Ratings

Table 1 Absolute Ratings of Environment

Item	Symbol	Min.	Max.	Unit	Conditions
Supply Voltage	V _{DD}	-0.5	5	V	-
Operating Temperature	TOP	-20	70	°C	Note
Storage Temperature	TST	-30	80	°C	Note

Note: Please make sure to keep the temperature of LCD module is less than 70°C.

Document Title	M150GNN2 R1 Tentative Product Information		Page No.	6/20	
Document No.		Issue Date	2013/02/05	Revision	V00

3.0 Pixel Format Image

Figure 2 shows the relationship of the input signals and LCD pixel format image.

Figure 2 Pixel Format

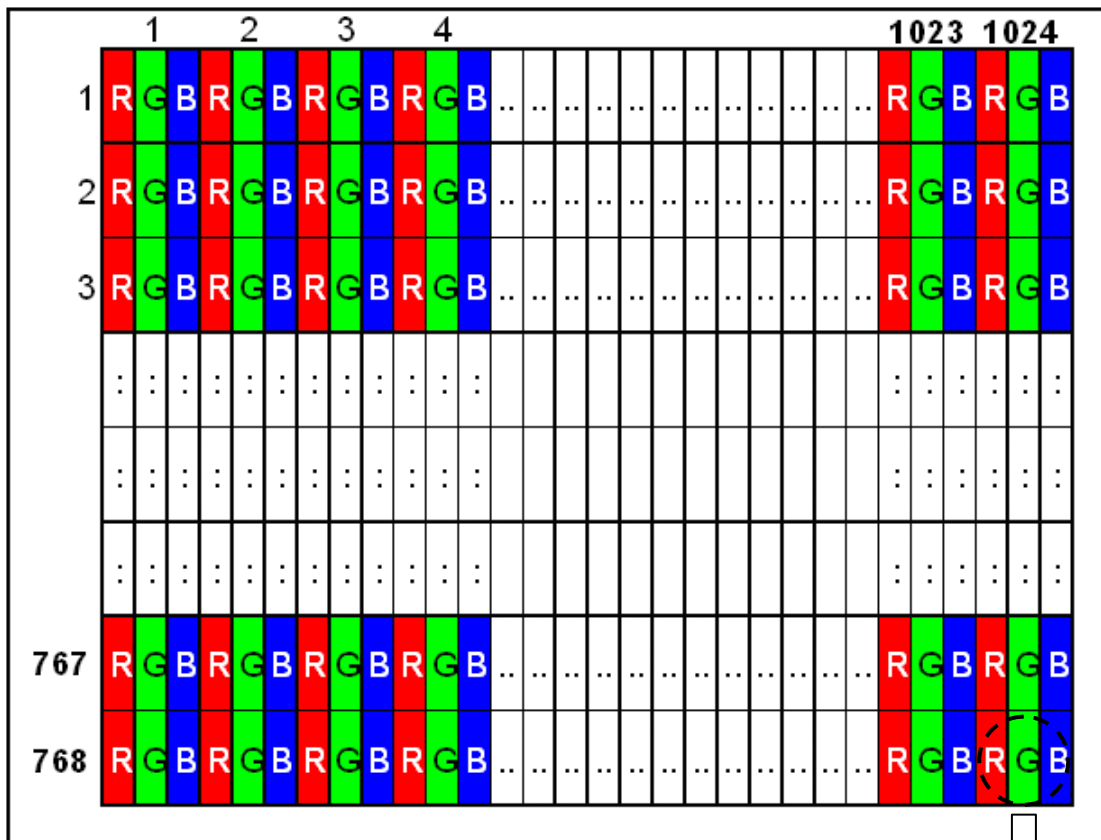

R+G+B dots=1 pixel



Document Title	M150GNN2 R1 Tentative Product Information		Page No.	7/20	
Document No.		Issue Date	2013/02/05	Revision	V00

4.0 Optical Characteristics

The optical characteristics are measured under stable conditions as following notes

Table 2 Optical Characteristics

Item	Conditions		Min.	Typ.	Max.	Unit	Note	
Viewing Angle (CR>10)	Horizontal	θ_L	70	80	-	degree	(1),(2),(3)	
		θ_R	70	80	-			
	Vertical	θ_T	70	80	-			
		θ_B	60	80	-			
Contrast Ratio	Center		450	800	-	-	(1),(2),(4)	
Response Time	Rising		-	-	-	ms	(1),(2),(5)	
	Falling		-	-	-	ms		
	Rising + Falling		-	16	-	ms		
Color Chromaticity (CIE1931)	NTSC		-	70	-	%	(1),(2)	
	Red	x	Typ. -0.03	(0.631)	Typ. +0.03	-	(1),(2)	
	Red	y		(0.354)		-		
	Green	x		(0.318)		-		
	Green	y		(0.630)		-		
	Blue	x		(0.147)		-		
	Blue	y		(0.075)		-		
	White	x		Typ. -0.05		(0.305)		Typ. +0.05
White	y	(0.325)		-				
White Luminance	Center		-	350	-	cd/m ²	(1),(2),(6)	
Luminance Uniformity	9Points		75	80	-	%	(1),(2),(6)	

Document Title	M150GNN2 R1 Tentative Product Information		Page No.	8/20
Document No.		Issue Date	2013/02/05	Revision
				V00

Note (1) Measurement Setup:

The LCD module should be stabilized at given temperature(25°C) for 15 minutes to Avoid abrupt temperature change during measuring. In order to stabilize the luminance, the measurement should be executed after lighting backlight for 15 minutes in a windless room.

Figure 3 Measurement Setup

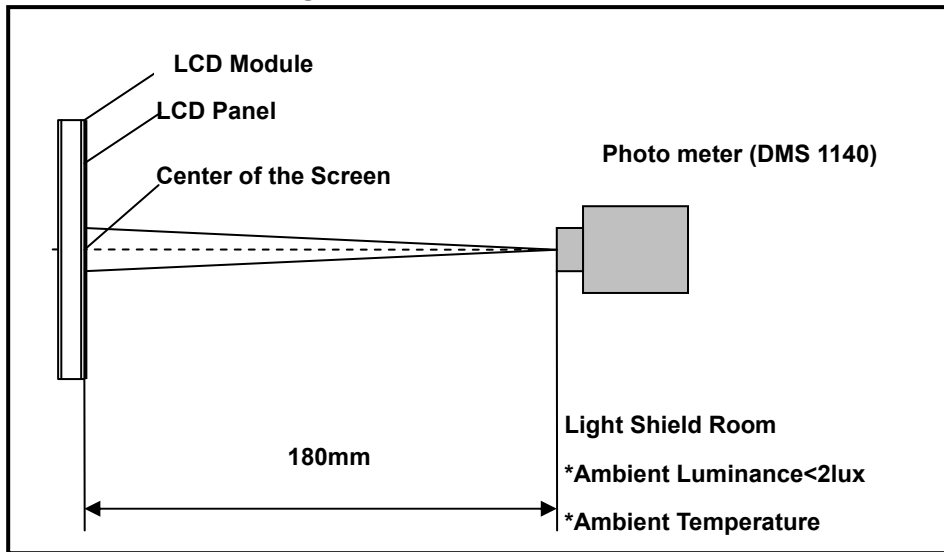

Note (2) The LED input parameter setting as:

VLED: 12V;

PWM_LED: Duty 100 %

Note (3) Definition of Viewing Angle

Figure 4 Definition of Viewing Angle

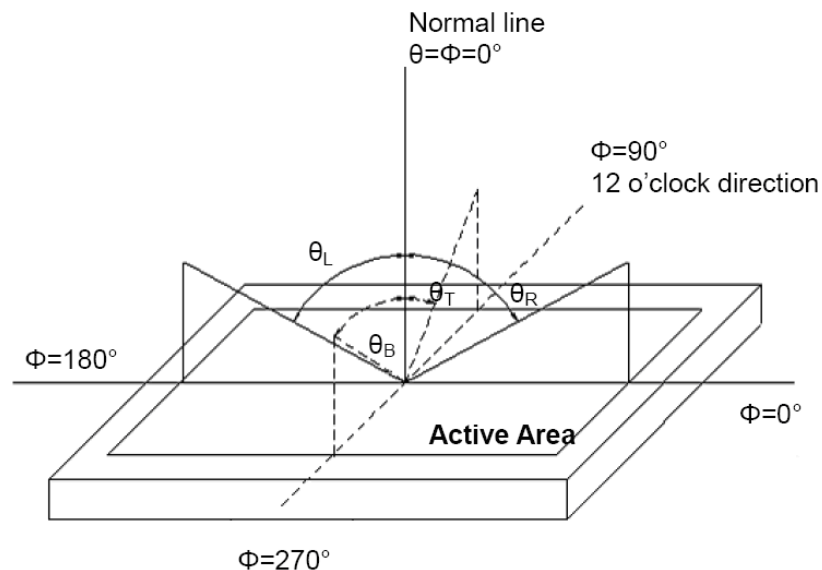

Document Title	M150GNN2 R1 Tentative Product Information		Page No.	9/20
Document No.		Issue Date	2013/02/05	Revision
				V00

Note (4) Definition Of Contrast Ratio (CR)

The contrast ratio can be calculated by the following expression

$$\text{Contrast Ratio (CR)} = L_{255} / L_0$$

L255: Luminance of gray level 255, L0: Luminance of gray level 0

Note (5) Definition Of Response Time (T_R , T_F)

Figure 5 Definition of Response Time

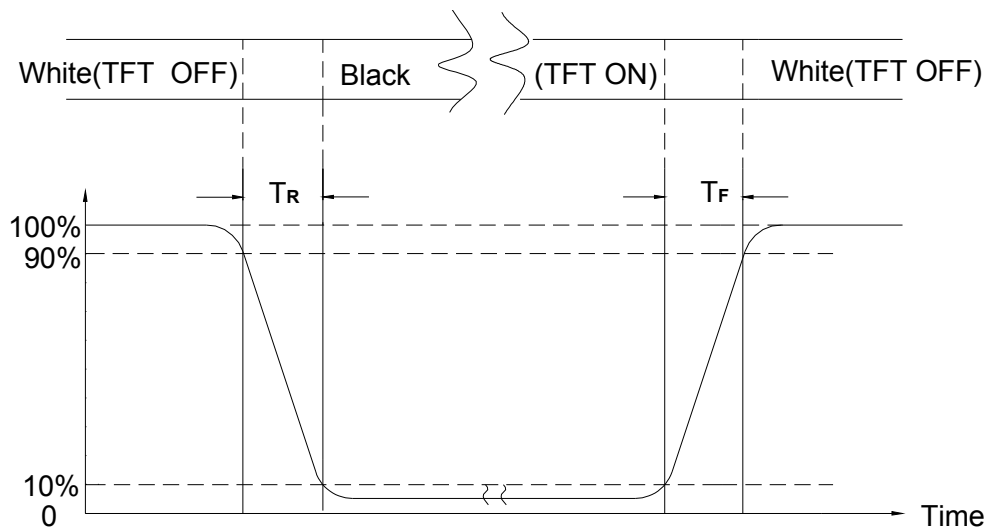

Note (6) Definition Of Brightness Luminance

$$\text{Luminance Uniformity} = \frac{(\text{Min Luminance of 9 points})}{(\text{Max Luminance of 9 points})} \times 100\%$$

Figure 6 Measurement Locations

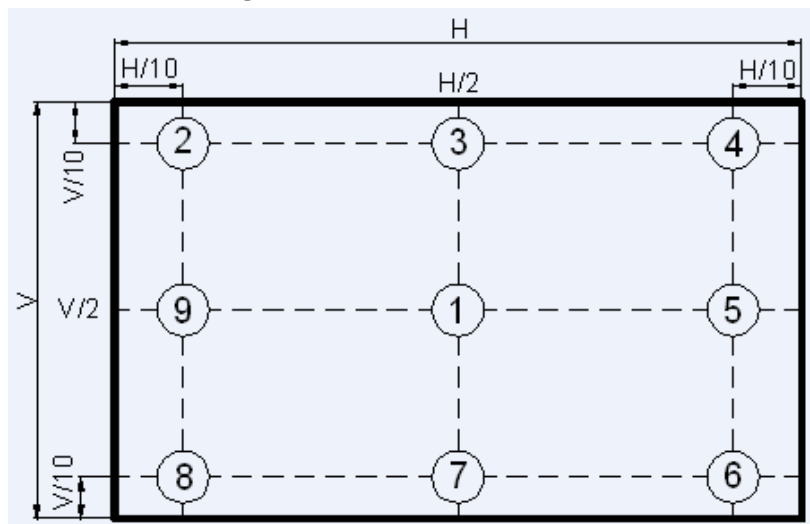



Document Title	M150GNN2 R1 Tentative Product Information	Page No.	10/20		
Document No.		Issue Date	2013/02/05	Revision	V00

5.0 Backlight Characteristics

5.1 Parameter Guideline of LED Backlight

Table 3 Parameter Guideline for LED Backlight

Symbol	Parameter	Min.	Typ.	Max.	Units	Condition
F _{PWM}	PWM dimming Frequency	200	-	20K	Hz	Ddim ≥ 5%
LT	LED Life Time	30,000	-	-	Hours	Ta=25°C Note A

Note A: The LED life time define as the estimated time to 50% degradation of initial luminous.



Document Title	M150GNN2 R1 Tentative Product Information	Page No.	11/20		
Document No.		Issue Date	2013/02/05	Revision	V00

6.0 Electrical Characteristics

6.1 TFT LCD Module Interface Connector

Table 4 Connector Name / Designation

Item	Description
Type / Part Number	MSB240420HD

Table 5 Signal Pin Assignment

Pin #	Signal Name	Description	Remarks
1	VDD	Power Supply, 3.3V (typical)	
2	VDD	Power Supply, 3.3V (typical)	
3	VSS	Ground	
4	REV	Reverse Scan selection	Note
5	Rin1-	-LVDS differential data input	
6	Rin1+	+LVDS differential data input	
7	VSS	Ground	
8	Rin2-	-LVDS differential data input	
9	Rin2+	+LVDS differential data input	
10	VSS	Ground	
11	Rin3-	-LVDS differential data input	
12	Rin3+	+LVDS differential data input	
13	VSS	Ground	
14	ClkIN-	-LVDS differential clock input	
15	ClkIN+	+LVDS differential clock input	
16	GND	Ground	
17	Rin4-	-LVDS differential data input	
18	Rin4+	+VDS differential data input	
19	VSS	Ground	
20	NC	Not connect	



Document Title	M150GNN2 R1 Tentative Product Information		Page No.	12/20	
Document No.		Issue Date	2013/02/05	Revision	V00

Note: I REV = LOW/NC

Gate Scan :

Y1→Y2→Y3

Y1 : G1→G2- - - - ->G258

Source Scan :

X1→X2→X3→X4→X5

X1: S1→S2- - - - ->S600

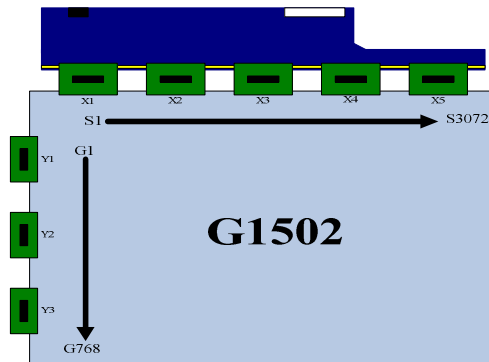

II REV = High

Gate Scan :

Y3→Y2→Y1

Y1 : G258→G257- - - - ->G1

Source Scan :

X5→X4→X3→X2→X1

X1: S600→S599- - - - ->S1

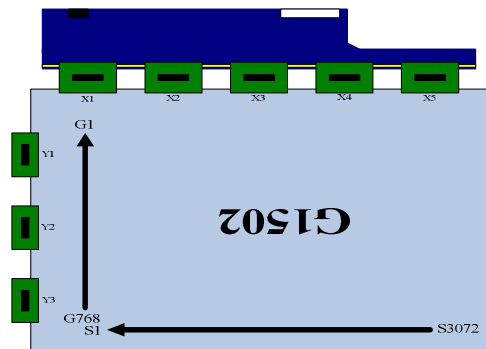



Document Title	M150GNN2 R1 Tentative Product Information	Page No.	13/20		
Document No.		Issue Date	2013/02/05	Revision	V00

6.2 LED Interface Connector

Table 6 Connector Name / Designation

Connector Name / Designation	LED Driver Connector
Manufacturer	ENTERY or compatible
Connector Model Number	3808K-F05N-02R or compatible
Mating Model Number	H208K-P05N-02B or compatible

Table 7 LED Connector Pin Assignment

Pin#	Symbol	Signal Name
1	Vcc	12V
2	GND	GND
3	Enable	5V-On / 0V-Off
4	Dimming	PWM Dimming or Analog Dimming
5	NC	NC



Document Title	M150GNN2 R1 Tentative Product Information			Page No.	14/20
Document No.		Issue Date	2013/02/05	Revision	V00

7.0 Interface Timings

7.1 Timing Characteristics

Table 8 Interface Timings

Synchronization Method : DE only

Parameter	Symbol	Unit	Min.	Typ.	Max.
LVDS Clock Frequency <single >	fdck	MHz	50	65	80
H Total Time	Thp	clocks	1056	1344	1720
H Active Time	HA	clocks	1024	1024	1024
H Front Porch	Thfp	clocks	-	48	-
H Sync Pulse Width	HSPW	clocks	-	32	-
H Back Porch	Thbp	clocks	-	240	-
H Frequency	fh	kHz	46.32	48.36	59.40
V Total Time	Tvp	lines	772	806	990
V Active Time	VA	lines	768	768	768
V Front Porch	Tvfp	lines	-	3	-
V Sync Pulse Width	VSPW	lines	-	12	-
V Back Porch	Tvbp	lines	-	23	-
V Frequency	fv	Hz		60	

Note: H Blank area and V Blank area can not be changed at every frame

7.2 Timing Diagram of Interface Signal

Figure 8 Timing Characteristics

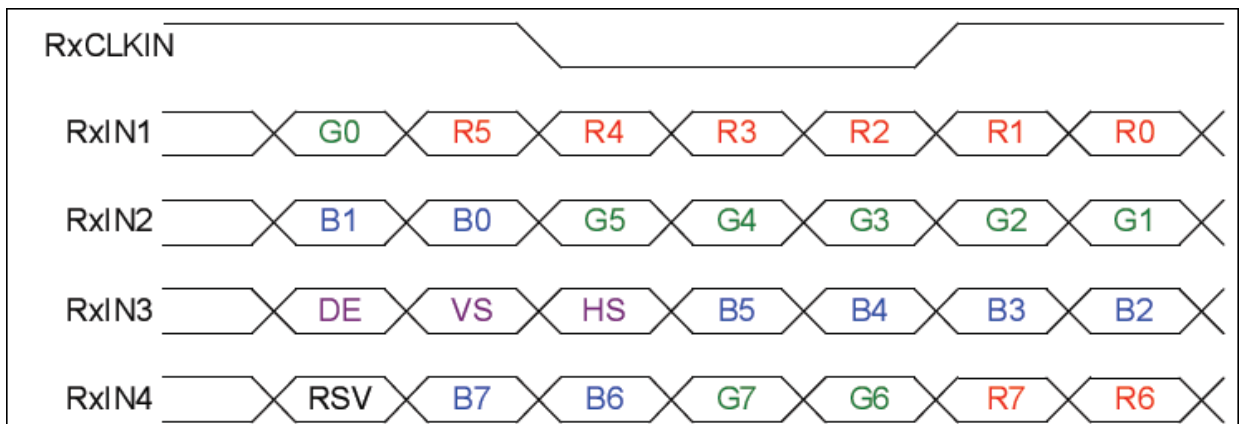

Note1 : Follow SPWG

Note2 : R/G/B data7: MSB, R/G/B data0: LSB

Document Title	M150GNN2 R1 Tentative Product Information	Page No.	15/20
Document No.		Issue Date	2013/02/05
		Revision	V00

8.0 Power Consumption

Input power specifications are as follows.

Table 9 Power Consumption

Symbol	Parameter	Min.	Typ.	Max.	Units	Condition
VDD	Logic/LCD Drive Voltage	3.0	3.3	3.6	[V]	-
IDD	VDD Current	-	0.25	-	[A]	3.3V/Black pattern
PDD	VDD Power	-	-	1.3	[W]	Black Pattern, 60Hz
Irush	Rush Current	-	-	0.75	[A]	Note1
VDDrp	Allowable Logic/LCD Drive Ripple Voltage	-	-	200	[mV]p-p	Note 2

Note 1.Measure Condition

Figure 9 VDD rising time

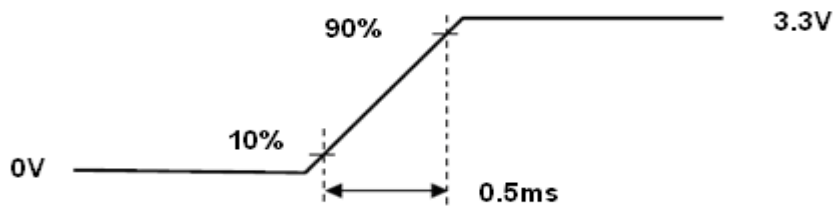

VDD rising time

Note 2. VDD Power Dip Condition

Figure 10 VDD Power Dip

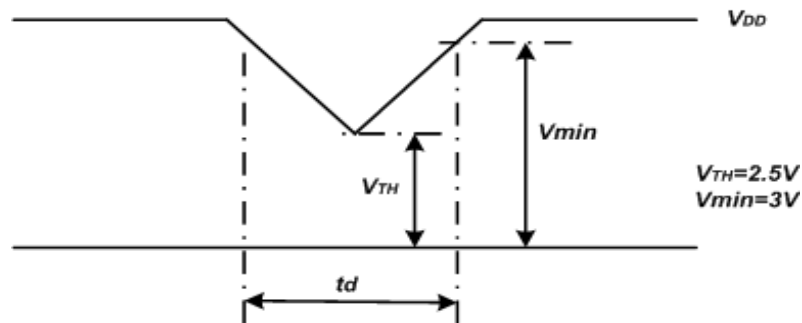

If $V_{TH} < V_{DD} \leq V_{min}$, then $t_d \leq 10ms$; When the voltage return to normal our panel must revive automatically.

Document Title	M150GNN2 R1 Tentative Product Information	Page No.	16/20
Document No.		Issue Date	2013/02/05
		Revision	V00

9.0 Power ON/OFF Sequence

VDD power on/off sequence is as follows. Interface signals are also shown in the chart. Signals from any system shall be Hi-Z state or low level when VDD is off.

Figure 11 Power Sequence

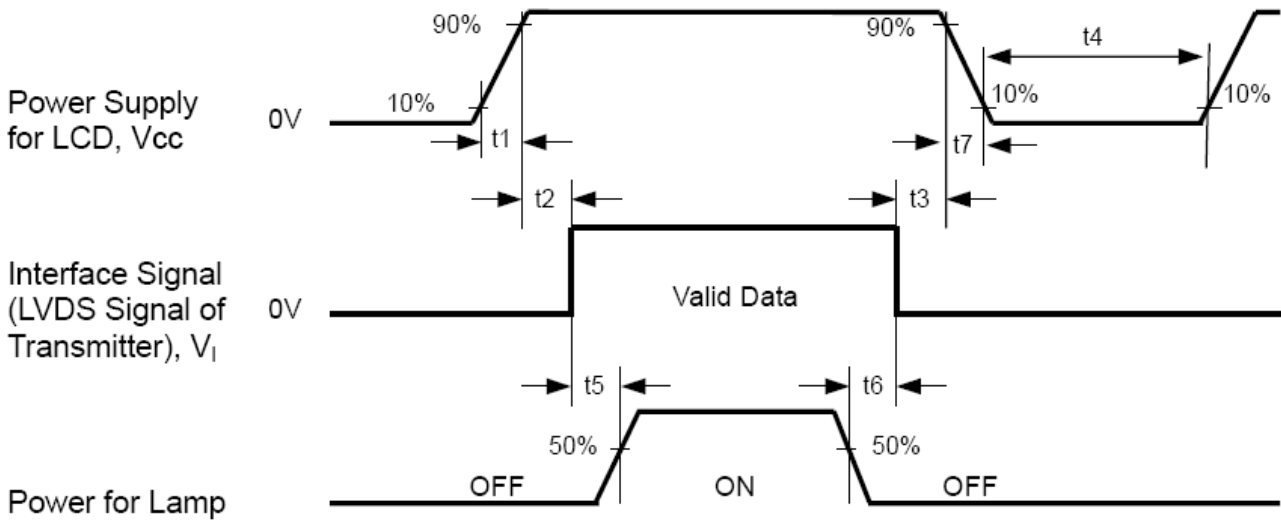

Table 10 Power Sequencing Requirements

Parameter	Symbol	Unit	min	typ	max
VDD Rise Time	T1	ms	0.02	-	10
VDD Good to Signal Valid	T2	ms	0	-	20
Signal Disable to Power Down	T3	ms	0	-	1000
Power Off	T4	ms	1000	-	
Signal Valid to Backlight On	T5	ms	300	-	
Backlight Off to Signal Disable	T6	ms	200	-	
VDD Fall Time	T7	ms	0	-	100



Document Title	M150GNN2 R1 Tentative Product Information		Page No.	17/20	
Document No.		Issue Date	2013/02/05	Revision	V00

10.0 Mechanical Characteristics

10.1 Outline Drawing

Figure 12 Reference Outline Drawing (Front Side)

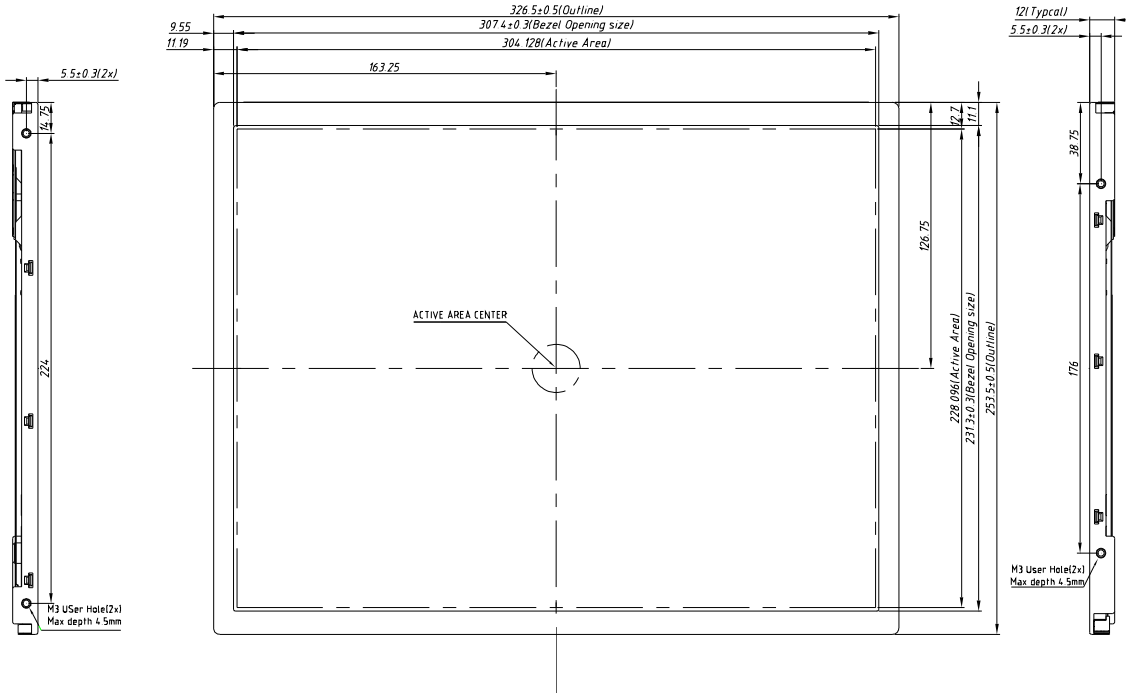
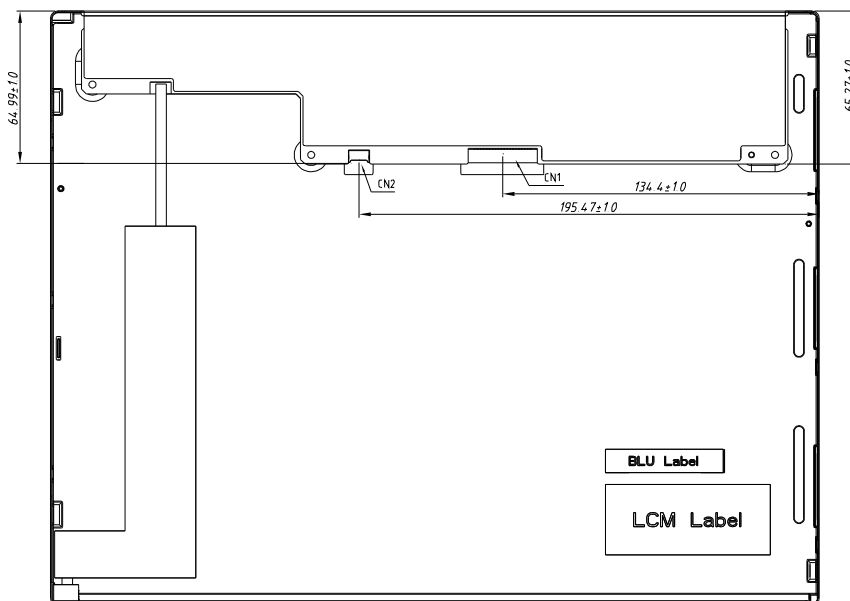

Figure 13 Reference Outline Drawing (Back Side)





Document Title	M150GNN2 R1 Tentative Product Information	Page No.	18/20		
Document No.		Issue Date	2013/02/05	Revision	V00

10.2 Dimension Specifications

Table 11 Module Dimension Specifications

Width [mm]	326.5 ± 0.5
Height [mm]	253.5 ± 0.5
Thickness [mm]	12 ± 0.5
Weight [g]	930(Typ) 960(Max)

11.0 Package Specification



Document Title	M150GNN2 R1 Tentative Product Information			Page No.	19/20
Document No.		Issue Date	2013/02/05	Revision	V00

12.0 General Precaution

12.1 Use Restriction

This product is not authorized for use in life supporting systems, aircraft navigation control systems, military systems and any other application where performance failure could be life-threatening or otherwise catastrophic.

12.2 Handling Precaution

- (1) Please mount LCD module by using mounting holes arranged in four corners tightly.
- (2) Do not disassemble or modify the module. It may damage sensitive parts inside LCD module, and may cause scratches or dust on the display. IVO does not warrant the module, if customers disassemble or modify the module.
- (3) If LCD panel is broken and liquid crystal spills out, do not ingest or inhale liquid Crystal, and do not contact liquid crystal with skin. If liquid crystal contacts mouth or eyes, rinse out with water immediately. If liquid crystal contacts skin or cloths, wash it off immediately with alcohol and Rinse thoroughly with water.
- (4) Disconnect power supply before handling LCD module
- (5) Refrain from strong mechanical shock and /or any force to the module.
- (6) Do not exceed the absolute maximum rating values, such as the supply voltage variation, input voltage variation, variation in parts' parameters, environmental temperature; etc otherwise LCD module may be damaged. It's recommended employing protection circuit for power supply.
- (7) Do not touch, push or rub the polarizer with anything harder than HB pencil lead. Use fingerstalls of soft gloves in order to keep clean display quality, when Persons handle the LCD module for incoming inspection or assembly.
- (8) When the surface is dusty, please wipe gently with absorbent cotton or other soft Material. When cleaning the adhesives, please use absorbent cotton wetted with a little Petroleum benzene or other adequate solvent.
- (9) Wipe off saliva or water drops as soon as possible. If saliva or water drops Contact with polarizer for a long time, they may causes deformation or color Fading.
- (10) Protection film must remove very slowly from the surface of LCD module to Prevent from electrostatic occurrence.
- (11) Because LCD module uses CMOS-IC on circuit board and TFT-LCD panel, it is Very weak to electrostatic discharge, Please be careful with electrostatic Discharge .Persons who handle the module should be grounded through adequate methods.
- (12) Do not adjust the variable resistor located on the module.

12.3 Storage Precaution

- (1) Please do not leave LCD module in the environment of high humidity and high temperature for a long time.
- (2) The module shall not be exposed under strong light such as direct sunlight. Otherwise, Display characteristics may be changed.
- (3) The module should be stored in a dark place. It is prohibited to apply sunlight or fluorescent light in storage.

12.4 Operation Precaution

- (1) Do not connect or disconnect the module in the "Power On" condition.
- (2) Power supply should always be turned on/off by 9.0 "Power on/off sequence"
- (3) Module has high frequency circuits. Sufficient suppression to the electromagnetic



Document Title	M150GNN2 R1 Tentative Product Information			Page No.	20/20
Document No.		Issue Date	2013/02/05	Revision	V00

interference should be done by system manufacturers. Grounding and shielding methods may be important to minimize the interference.

- (4) After installation of the TFT Module into an enclosure, do not twist nor bend the TFT Module even momentary. At designing the enclosure, it should be taken into consideration that no bending/twisting forces are applied to the TFT Module from outside. Otherwise the TFT Module may be damaged.

12.5 Others

- (1) Ultra-violet ray filter is necessary for outdoor operation.
- (2) Avoid condensation of water which may result in improper operation or disconnection of electrode.
- (3) If the module keeps displaying the same pattern for a long period of time, the image may be "sticked" to the screen.
- (4) This module has its circuitry PCB's on the rear side and should be handled carefully in order not to be stressed.

12.6 Disposal

When disposing LCD module, obey the local environmental regulations.