



**TFT LCD Approval Specification**

**MODEL NO.: M150X4 -L06**

Customer : \_\_\_\_\_

Approved by : \_\_\_\_\_

Note :

Liquid Crystal Display Division		
QRA Dept.	TDD I Dept.	PDD I Dept.
Approval	Approval	Approval
	李 廷 洋 92.6.9	

## - CONTENTS -

REVISION HISTORY	-----	3
1. GENERAL DESCRIPTION	-----	5
1.1 OVERVIEW		
1.2 FEATURES		
1.3 APPLICATION		
1.4 GENERAL SPECIFICATIONS		
1.5 MECHANICAL SPECIFICATIONS		
2. ABSOLUTE MAXIMUM RATINGS	-----	6
2.1 ABSOLUTE RATINGS OF ENVIRONMENT		
2.2 ELECTRICAL ABSOLUTE RATINGS		
2.2.1 TFT LCD MODULE		
2.2.2 BACKLIGHT UNIT		
3. ELECTRICAL CHARACTERISTICS	-----	8
3.1 TFT LCD MODULE		
3.2 BACKLIGHT UNIT		
4. BLOCK DIAGRAM	-----	11
4.1 TFT LCD MODULE		
4.2 BACKLIGHT UNIT		
5. INPUT TERMINAL PIN ASSIGNMENT	-----	12
5.1 TFT LCD MODULE		
5.2 BACKLIGHT UNIT		
5.3 COLOR DATA INPUT ASSIGNMENT		
6. INTERFACE TIMING	-----	14
6.1 INPUT SIGNAL TIMING SPECIFICATIONS		
6.2 POWER ON/OFF SEQUENCE		
7. OPTICAL CHARACTERISTICS	-----	17
7.1 TEST CONDITIONS		
7.2 OPTICAL SPECIFICATIONS		
8. PRECAUTIONS	-----	20
8.1 HANDLING PRECAUTIONS		
8.2 STORAGE PRECAUTIONS		
8.3 OPERATION PRECAUTIONS		
9. PACKAGING	-----	22
9.1 PACKING SPECIFICATIONS		
9.2 PACKING METHOD		
10. INCOMING INSPECTION DAY	-----	24
11. DEFINITION OF SHIPPING LABEL ON MODULE	-----	25

### REVISION HISTORY

Version	Date	Page (New)	Section	Description
Ver 0.0	Aug.15,'2002	All	All	Tentative Specification was first issued.
Ver 0.1	Oct.07,'2002	7	3.1	Power Supply Current White : TBD(Typ.)→400(Typ.).
				Power Supply Current Black : TBD(Typ.)→550(Typ.).
		9	3.2	Lamp Turn On Voltage : (1150)(25°C)(Max.)→ (1180)(25°C)(Max.).
				Lamp Turn On Voltage : (1360)(0°C)(Max.)→ (1330)(0°C)(Max.).
		16	7.2	Response Time TR:5(Typ.) / TF:12(Typ.) → TR:6(Typ.) / TF:17(Typ.)
				Response Time TR:TBD(Max.) / TF:TBD(Max.) → TR:10(Max.) / TF:25(Max.)
Ver.1.0	Nov.25,'2002	4	1.5	Module Size
				Horizontal : 320.5(Min.)/321.5(Max.)
				Vertical : 244.9(Min.)/245.9(Max.)
				Depth : 10(Max.)
		6	2.2.2	Lamp Voltage VL : 603(Min.)/737(Max.) → -(Min.)/2.5K(Max.)
				Lamp Current IL : 2.0(Min.)/9(Max.) → -(Min.)/8.5(Max.)
				Lamp Frequency FL : 30(Min.) → -(Min.)
		9	3.2	Lamp Input Voltage VL : 580(Typ.)/638(Max.) → 585(Typ.)/644(Max.)
				Lamp Turn On Voltage Vs : 1330(0°C)(Max.) → 1350(0°C)(Max.)
				Operating Frequency FL :30(Min.)/45(Typ.) → 40(Min.)/50(Typ.)
				Power Consumption PL : 9.28(Typ.) → 9.36(typ.)
		16	7.2	White Variation δW : 1.35(Max.) → 1.40(Max.)
				Color Chromaticity
				Rx :
				0.597(Min.)/0.627(typ.)/0.657(Max.) → 0.602(Min.)/0.633(typ.)/0.663(Max.)
				Gx :
				0.265(Min.)/0.295(Typ.)/0.325(Max.) → 0.270(Min.)/0.300(Typ.)/0.330(Max.)
				Gy :
				0.559(Min.)/0.589(Typ.)/0.619(Max.) → 0.556(Min.)/0.586(Typ.)/0.616(Max.)
				Bx :
				0.114(Min.)/0.144(Typ.)/0.174(Max.) → 0.112(Min.)/0.142(Typ.)/0.172(Max.)
Ver.2.0	Jan.06,'2003	16	7.2	Color Chromaticity
				Rx :
				0.602(Min.)/0.633(typ.)/0.663(Max.)→ 0.597(Min.)/0.627(typ.)/0.657(Max.)
				Gx :
				0.270(Min.)/0.300(Typ.)/0.330(Max.)→ 0.265(Min.)/0.295(Typ.)/0.325(Max.)
				Gy :
				0.556(Min.)/0.586(Typ.)/0.616(Max.)→ 0.559(Min.)/0.589(Typ.)/0.619(Max.)
				Bx :
				0.112(Min.)/0.142(Typ.)/0.172(Max.)→ 0.114(Min.)/0.144(Typ.)/0.174(Max.)
Ver.2.1	Jan.10,'2003	17	7.2	Color Chromaticity
				Rx :
				0.597(Min.)/0.627(typ.)/0.657(Max.) → 0.603(Min.)/0.633(typ.)/0.663(Max.)
				Ry :
				0.331(Min.)/0.361(Typ.)/0.391(Max.) → 0.327(Min.)/0.357(Typ.)/0.387(Max.)

### REVISION HISTORY

Version	Date	Page (New)	Section	Description
Ver.2.1	Jan.10,'2003	17	7.2	Gx : 0.266(Min.)/0.296(Typ.)/0.326(Max.) → 0.270(Min.)/0.300(Typ.)/0.330(Max.) Gy : 0.561(Min.)/0.591(Typ.)/0.621(Max.) → 0.556(Min.)/0.586(Typ.)/0.616(Max.) Bx : 0.111(Min.)/0.141(Typ.)/0.171(Max.) → 0.112(Min.)/0.142(Typ.)/0.172(Max.) By : 0.067(Min.)/0.097(Typ.)/0.127(Max.) → 0.064(Min.)/0.094(Typ.)/0.124(Max.)
Ver.2.2	Mar.21,'2003	10	3.2	Modified power consumption Unit from mW to W
Ver.2.3	Jun.05,'2003	11	4.1	Modify LAMP CONNECTOR : JST BHSR-03VS-1 → JST BHR-03VS-1

## 1. GENERAL DESCRIPTION

### 1.1 OVERVIEW

M150X4-L06 is a 15.0" TFT Liquid Crystal Display module with 2 CCFL Backlight units and 20 pins LVDS interface. This module supports 1024 x 768 XGA mode and can display 16.2M colors. The optimum viewing angle is at 6 o'clock direction. The inverter module for Backlight is not built in.

### 1.2 FEATURES

- XGA (1024 x 768 pixels) resolution
- DE(Data Enable) only mode
- LVDS Interface with 1pixel/clock

### 1.3 APPLICATION

- Desktop monitors

### 1.4 GENERAL SPECIFICATIONS

Item	Specification	Unit	Note
Active Area	304.128(H) x 228.096(V) (15.0" diagonal)	mm	(1)
Bezel Opening Area	307.5(H) x 231.4(V)	mm	
Driver Element	a-Si TFT active matrix	-	-
Pixel Number	1024 x R.G.B. x 768	pixel	-
Pixel Pitch	0.297(H) x 0.297(W)	mm	-
Pixel Arrangement	RGB vertical stripe	-	-
Display Colors	16,194,277	color	-
Transmissive Mode	Normally white	-	-

### 1.5 MECHANICAL SPECIFICATIONS

Item	Min.	Typ.	Max.	Unit	Note	
Module Size	Horizontal(H)	320.5	321.0	321.5	mm	(1)
	Vertical(V)	244.9	245.4	245.9	mm	
	Depth(D)	-	9.7	10	mm	(1)(2)
Weight	-	-	930	g	-	

Note (1) Please refer to the attached drawings for more information of front and back outline dimensions.

Note (2) The depth is without connector.

## 2. ABSOLUTE MAXIMUM RATINGS

### 2.1 ABSOLUTE RATINGS OF ENVIRONMENT

Item	Symbol	Value		Unit	Note
		Min.	Max.		
Storage Temperature	T <sub>ST</sub>	-20	+60	°C	(1)
Operating Ambient Temperature	T <sub>OP</sub>	0	+50	°C	(1), (2)
Storage Humidity	H <sub>ST</sub>	10	90	%	-
Operation Humidity	H <sub>OP</sub>	10	90	%	-
Shock (Non-Operating)	S <sub>NOP</sub>	-	50	G	(3), (5)
Vibration (Non-Operating)	V <sub>NOP</sub>	-	1.5	G	(4), (5)

Note (1) Temperature and relative humidity range is shown in the figure below.

- (a) 90 %RH Max. (Ta ≤ 40 °C).
- (b) Wet-bulb temperature should be 39 °C Max. (Ta > 40 °C).
- (c) No condensation of water.

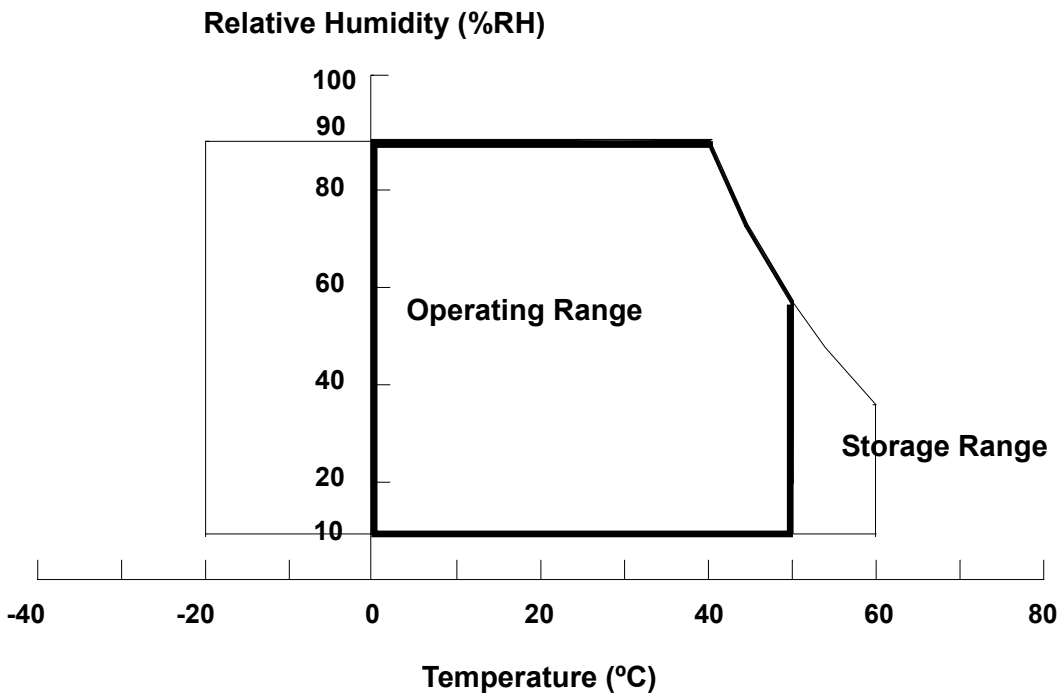

Note (2) The temperature of panel surface should be 0 °C Min. and 60 °C Max.

Note (3) 11ms, 1 time each ±X,±Y and ±Z directions

Note (4) 10 ~ 500 Hz, 1 cycle/20min. 1.5mm max, 1 hour each X, Y and Z directions

Note (5) At testing Vibration and Shock, the fixture in holding the module has to be hard and rigid enough so that the module would not be twisted or bent by the fixture.

## 2.2 ELECTRICAL ABSOLUTE RATINGS

### 2.2.1 TFT LCD MODULE

Item	Symbol	Value		Unit	Note
		Min.	Max.		
Power Supply Voltage	V <sub>DD</sub>	-0.3	4.0	V	

### 2.2.2 BACKLIGHT UNIT

Item	Symbol	Value		Unit	Note
		Min.	Max.		
Lamp Voltage	V <sub>L</sub>	-	2.5K	V <sub>RMS</sub>	(1), (2), I <sub>L</sub> = 8 mA
Lamp Current	I <sub>L</sub>	-	8.5	mA <sub>RMS</sub>	(1), (2)
Lamp Frequency	F <sub>L</sub>	-	80	KHz	

Note (1) Permanent damage to the device may occur if maximum values are exceeded. Function operation should be restricted to the conditions described under Normal Operating Conditions.

Note (2) Specified values are for lamp (Refer to Section 3.2 for further information).

### 3. ELECTRICAL CHARACTERISTICS

#### 3.1 TFT LCD MODULE<sub>(1)</sub>

Parameter	Symbol	Value			Unit	Note	
		Min.	Typ.	Max.			
Power Supply Voltage	$V_{DD}$	3.0	3.3	3.6	V	-	
Ripple Voltage	$V_{RP}$	-	-	100	mVp-p		
Rush Current	$I_{RUSH}$	-	-	2.0	A	(2)	
Power Supply Current	White	-	400		mA	(3)a	
	Black	-	550		mA	(3)b	
Differential Input Voltage for LVDS Receiver Threshold	"H" Level	$V_{IH}$	-	-	100	mV	-
	"L" Level	$V_{IL}$	-100	-	-	mV	-
Terminating Resistor	$R_T$	-	100	-	Ohm	-	

Note (1) The module should be always operated within above ranges.

Note (2) Measurement Conditions:

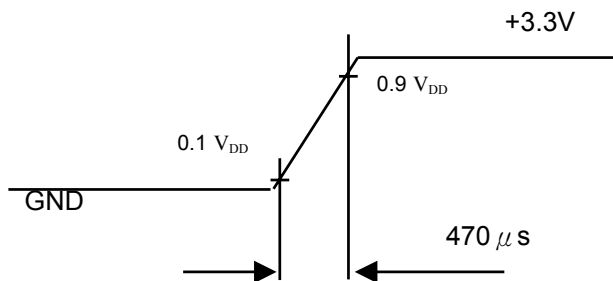
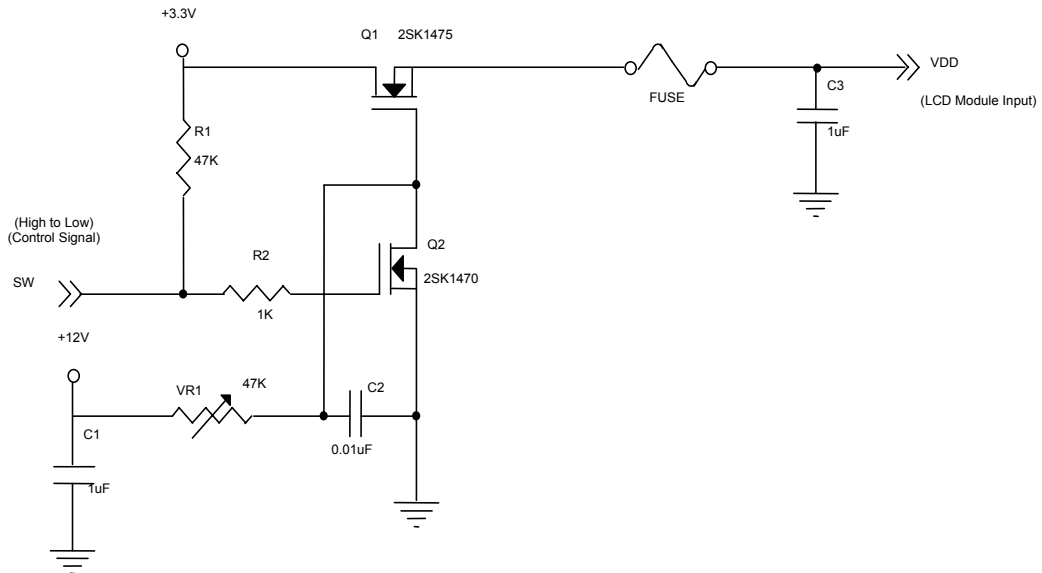



Note (3) The specified power supply current is under the conditions at  $V_{DD} = 3.3V$ ,  $T_a = 25 \pm 2 \text{ }^\circ\text{C}$ , DC Current and  $f_v = 60 \text{ Hz}$ , whereas a power dissipation check pattern below is displayed.

a. White Pattern

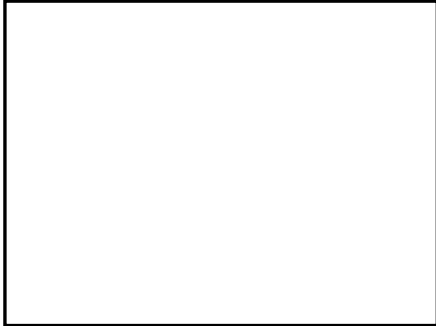

Active Area

b. Black Pattern



Active Area

## 3.2 BACKLIGHT UNIT

 $T_a = 25 \pm 2 \text{ }^\circ\text{C}$ 

Parameter	Symbol	Value			Unit	Note
		Min.	Typ.	Max.		
Lamp Input Voltage	$V_L$	522	585	644	$V_{RMS}$	$I_L = 8 \text{ mA}$
Lamp Current	$I_L$	2.0	8.0	8.5	$\text{mA}_{RMS}$	(1)
Lamp Turn On Voltage	$V_S$	-	-	1180 (25 $^\circ\text{C}$ )	$V_{RMS}$	(2)
		-	-	1350 (0 $^\circ\text{C}$ )	$V_{RMS}$	(2)
Operating Frequency	$F_L$	40	50	80	KHz	(3)
Lamp Life Time	$L_{BL}$	40000		-	Hrs	(5)
Power Consumption	$P_L$	-	9.36	-	W	(4), $I_L = 8 \text{ mA}$

Note (1) Lamp current is measured by utilizing a high frequency current meter as shown below:

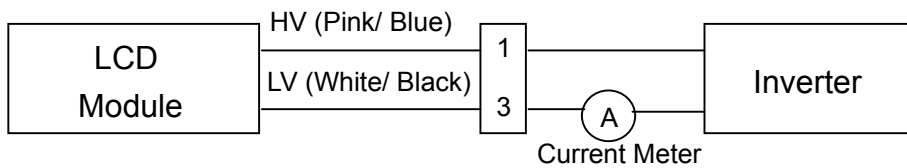

Note (2) The voltage shown above should be applied to the lamp for more than 1 second after startup. Otherwise the lamp may not be turned on.

Note (3) The lamp frequency may generate interference with horizontal synchronous frequency from the display, and this may cause line flow on the display. In order to avoid interference, the lamp frequency should be detached from the horizontal synchronous frequency and its harmonics as far as possible.

Note (4)  $P_L = I_L \times V_L$

Note (5) The lifetime of lamp is defined as the time when it continues to operate under the conditions at  $T_a = 25 \pm 2 \text{ }^\circ\text{C}$  and  $I_L = 8.0 \text{ mA}_{RMS}$  until one of the following events occurs:

(a) When the brightness becomes  $\leq 50\%$  of its original value.

(b) When the effective ignition length becomes  $\leq 80\%$  of its original value. (Effective ignition length is defined as an area that the brightness is less than 70% compared to the center point.)

Note (6) The waveform of the voltage output of inverter must be area-symmetric and the design of the inverter must have specifications for the modularized lamp. The performance of the Backlight, such as lifetime or brightness, is greatly influenced by the characteristics of the DC-AC inverter for the lamp. All the parameters of an inverter should be carefully designed to avoid generating too much current leakage from high voltage output of the inverter. When designing or ordering the inverter please make sure that a poor lighting caused by the mismatch of the Backlight and the inverter (miss-lighting, flicker, etc.) never occurs. If the above situation is confirmed, the module should be operated in the same manners when it is installed in your instrument.

4. BLOCK DIAGRAM

4.1 TFT LCD MODULE

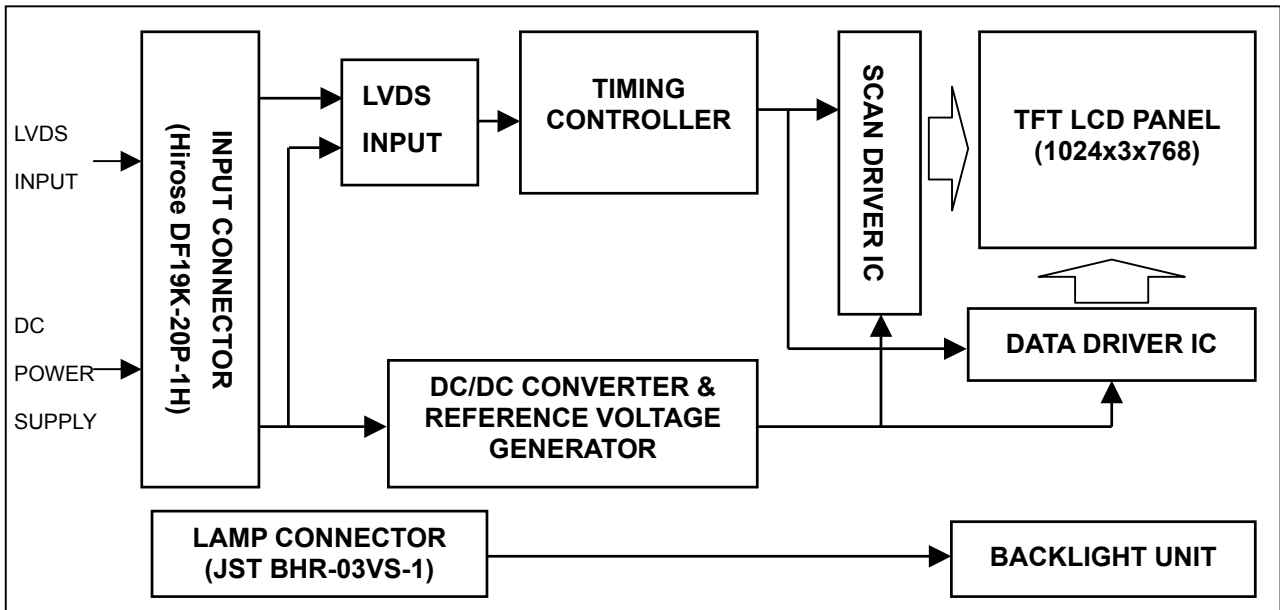

4.2 BACKLIGHT UNIT

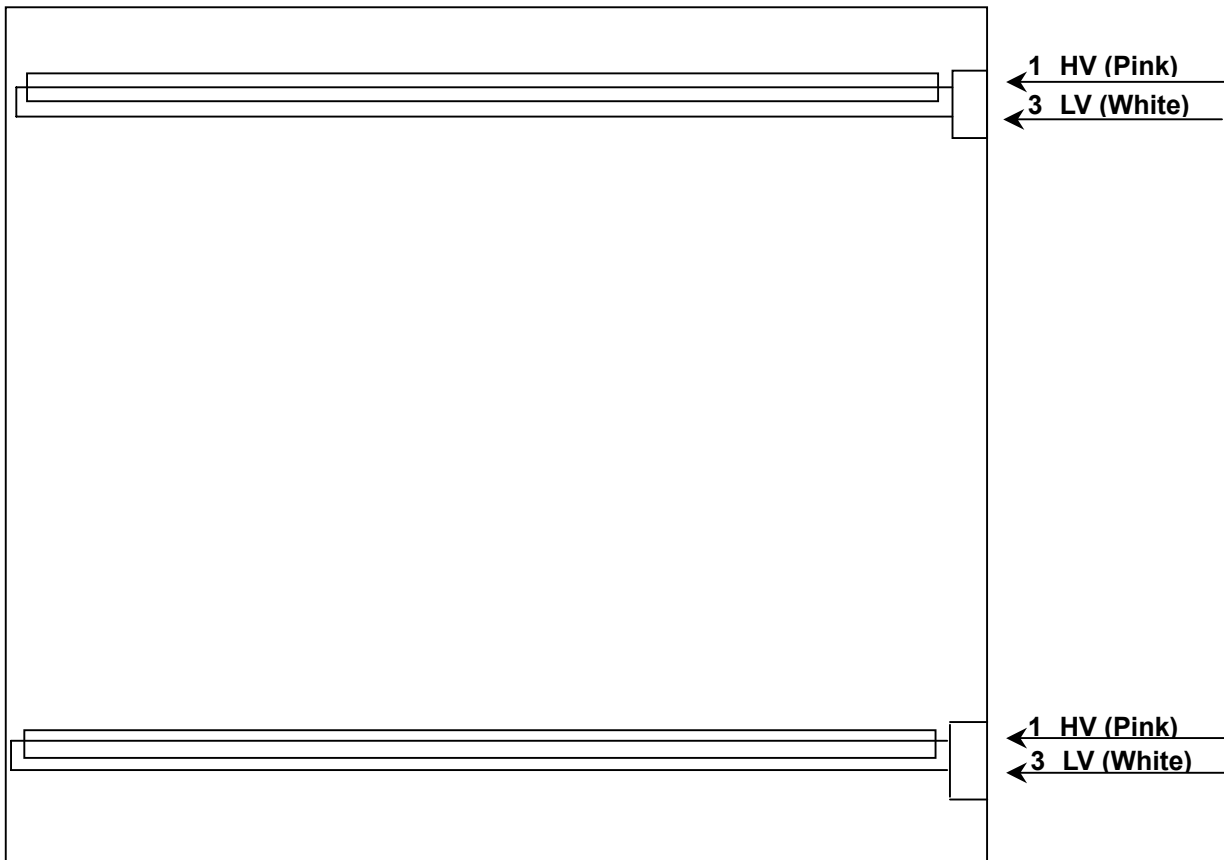

## 5. INPUT TERMINAL PIN ASSIGNMENT

### 5.1 TFT LCD MODULE

Pin No.	Symbol	Function	Polarity	Note
1	VDD	Power Supply +3.3V(typical)		
2	VDD	Power Supply +3.3V(typical)		
3	GND	Ground		
4	GND	Ground		
5	RX0-	LVDS Differential Data Input	Negative	
6	RX0+	LVDS Differential Data Input	Positive	
7	GND	Ground		
8	RX1-	LVDS Differential Data Input	Negative	
9	RX1+	LVDS Differential Data Input	Positive	
10	GND	Ground		
11	RX2-	LVDS Differential Data Input	Negative	
12	RX2+	LVDS Differential Data Input	Positive	
13	GND	Ground		
14	RXCLK-	LVDS Differential Data Input	Negative	
15	RXCLK+	LVDS Differential Data Input	Positive	
16	GND	Ground		
17	RX3-	LVDS Differential Data Input	Negative	
18	RX3+	LVDS Differential Data Input	Positive	
19	GND	GND		
20	NC	Reserved		

(1)Connector Part No.: [Hirose] DF19K-20P-1H

(2)Matching socket Part No.: [Hirose] DF19-20S-1C

### 5.2 BACKLIGHT UNIT

Pin	Symbol	Description	Color
1	HV1	High Voltage	Pink/ Blue
3	LV	Ground	White/ Black

Note (1) Connector Part No.: BHR-03VS-1 (JST) or equivalent

Note (2) Matching Connector Part No.: SM02B-BHS-1-TB (JST) or equivalent

### 5.3 COLOR DATA INPUT ASSIGNMENT

The brightness of each primary color (red, green and blue) is based on the 8-bit gray scale data input for the color. The higher the binary input the brighter the color. The table below provides the assignment of color versus data input.

Color		Data Signal																							
		Red								Green								Blue							
		R7	R6	R5	R4	R3	R2	R1	R0	R7	R6	G5	G4	G3	G2	G1	G0	R7	R6	B5	B4	B3	B2	B1	B0
Basic Colors	Black	0	0	0	0	0	0	0	0	0	0	0	0	0	0	0	0	0	0	0	0	0	0	0	0
	Red	1	1	1	1	1	1	1	1	0	0	0	0	0	0	0	0	0	0	0	0	0	0	0	0
	Green	0	0	0	0	0	0	0	0	1	1	1	1	1	1	1	1	0	0	0	0	0	0	0	0
	Blue	0	0	0	0	0	0	0	0	0	0	0	0	0	0	0	0	1	1	1	1	1	1	1	1
	Cyan	0	0	0	0	0	0	0	0	1	1	1	1	1	1	1	1	1	1	1	1	1	1	1	1
	Magenta	1	1	1	1	1	1	1	1	0	0	0	0	0	0	0	0	1	1	1	1	1	1	1	1
	Yellow	1	1	1	1	1	1	1	1	1	1	1	1	1	1	1	1	0	0	0	0	0	0	0	0
	White	1	1	1	1	1	1	1	1	1	1	1	1	1	1	1	1	1	1	1	1	1	1	1	1
Gray Scale Of Red	Red(0) / Dark	0	0	0	0	0	0	0	0	0	0	0	0	0	0	0	0	0	0	0	0	0	0	0	
	Red(1)	0	0	0	0	0	0	1	0	0	0	0	0	0	0	0	0	0	0	0	0	0	0	0	
	Red(2)	0	0	0	0	0	1	0	0	0	0	0	0	0	0	0	0	0	0	0	0	0	0	0	
	⋮	⋮	⋮	⋮	⋮	⋮	⋮	⋮	⋮	⋮	⋮	⋮	⋮	⋮	⋮	⋮	⋮	⋮	⋮	⋮	⋮	⋮	⋮	⋮	
	⋮	⋮	⋮	⋮	⋮	⋮	⋮	⋮	⋮	⋮	⋮	⋮	⋮	⋮	⋮	⋮	⋮	⋮	⋮	⋮	⋮	⋮	⋮	⋮	
	Red(252)	1	1	1	1	1	1	0	1	0	0	0	0	0	0	0	0	0	0	0	0	0	0	0	
	Red(252)	1	1	1	1	1	1	1	0	0	0	0	0	0	0	0	0	0	0	0	0	0	0	0	
	Red(252)	1	1	1	1	1	1	1	1	0	0	0	0	0	0	0	0	0	0	0	0	0	0	0	
Gray Scale Of Green	Green(0)/Dark	0	0	0	0	0	0	0	0	0	0	0	0	0	0	0	0	0	0	0	0	0	0	0	
	Green(1)	0	0	0	0	0	0	0	0	0	0	0	0	0	0	1	0	0	0	0	0	0	0	0	
	Green(2)	0	0	0	0	0	0	0	0	0	0	0	0	0	1	0	0	0	0	0	0	0	0	0	
	⋮	⋮	⋮	⋮	⋮	⋮	⋮	⋮	⋮	⋮	⋮	⋮	⋮	⋮	⋮	⋮	⋮	⋮	⋮	⋮	⋮	⋮	⋮		
	⋮	⋮	⋮	⋮	⋮	⋮	⋮	⋮	⋮	⋮	⋮	⋮	⋮	⋮	⋮	⋮	⋮	⋮	⋮	⋮	⋮	⋮	⋮		
	Green(252)	0	0	0	0	0	0	0	1	1	1	1	1	1	0	1	0	0	0	0	0	0	0	0	
	Green(252)	0	0	0	0	0	0	0	1	1	1	1	1	1	1	0	0	0	0	0	0	0	0	0	
	Green(252)	0	0	0	0	0	0	0	1	1	1	1	1	1	1	1	0	0	0	0	0	0	0	0	
Gray Scale Of Blue	Blue(0) / Dark	0	0	0	0	0	0	0	0	0	0	0	0	0	0	0	0	0	0	0	0	0	0	0	
	Blue(1)	0	0	0	0	0	0	0	0	0	0	0	0	0	0	0	0	0	0	0	0	0	0	1	
	Blue(2)	0	0	0	0	0	0	0	0	0	0	0	0	0	0	0	0	0	0	0	0	0	1	0	
	⋮	⋮	⋮	⋮	⋮	⋮	⋮	⋮	⋮	⋮	⋮	⋮	⋮	⋮	⋮	⋮	⋮	⋮	⋮	⋮	⋮	⋮	⋮		
	⋮	⋮	⋮	⋮	⋮	⋮	⋮	⋮	⋮	⋮	⋮	⋮	⋮	⋮	⋮	⋮	⋮	⋮	⋮	⋮	⋮	⋮	⋮		
	Blue(252)	0	0	0	0	0	0	0	0	0	0	0	0	0	0	1	1	1	1	1	1	1	0	1	
	Blue(252)	0	0	0	0	0	0	0	0	0	0	0	0	0	0	1	1	1	1	1	1	1	1	0	
	Blue(252)	0	0	0	0	0	0	0	0	0	0	0	0	0	0	1	1	1	1	1	1	1	1	1	

Note (1) 0: Low Level Voltage, 1: High Level Voltage

## 6. INTERFACE TIMING

### 6.1 INPUT SIGNAL TIMING SPECIFICATIONS

The input signal timing specifications are shown as the following table and timing diagram.

Signal	Item	Symbol	Min.	Typ.	Max.	Unit	Note
DCLK	Pixel Clock	$1/T_C$	-	65	80	MHz	-
DE	Vertical Total Time	$T_V$	769	806	1200	$T_H$	-
	Vertical Address Time	$T_{VD}$	768	768	768	$T_H$	-
	Horizontal Total Time	$T_H$	1120	1344	1600	$T_C$	-
	Horizontal Address Time	$T_{HD}$	1024	1024	1024	$T_C$	-

Note (1) Because this module is operated by DE only mode, Hsync and Vsync input signals should be set to low logic level or ground. Otherwise, this module would operate abnormally.

#### INPUT SIGNAL TIMING DIAGRAM

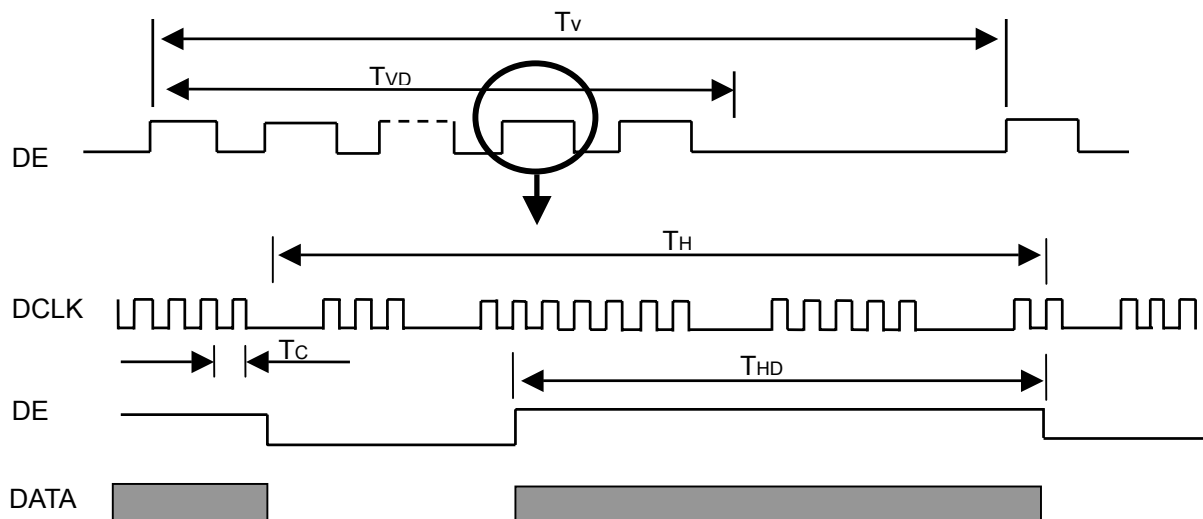

### TIMING DIAGRAM of LVDS

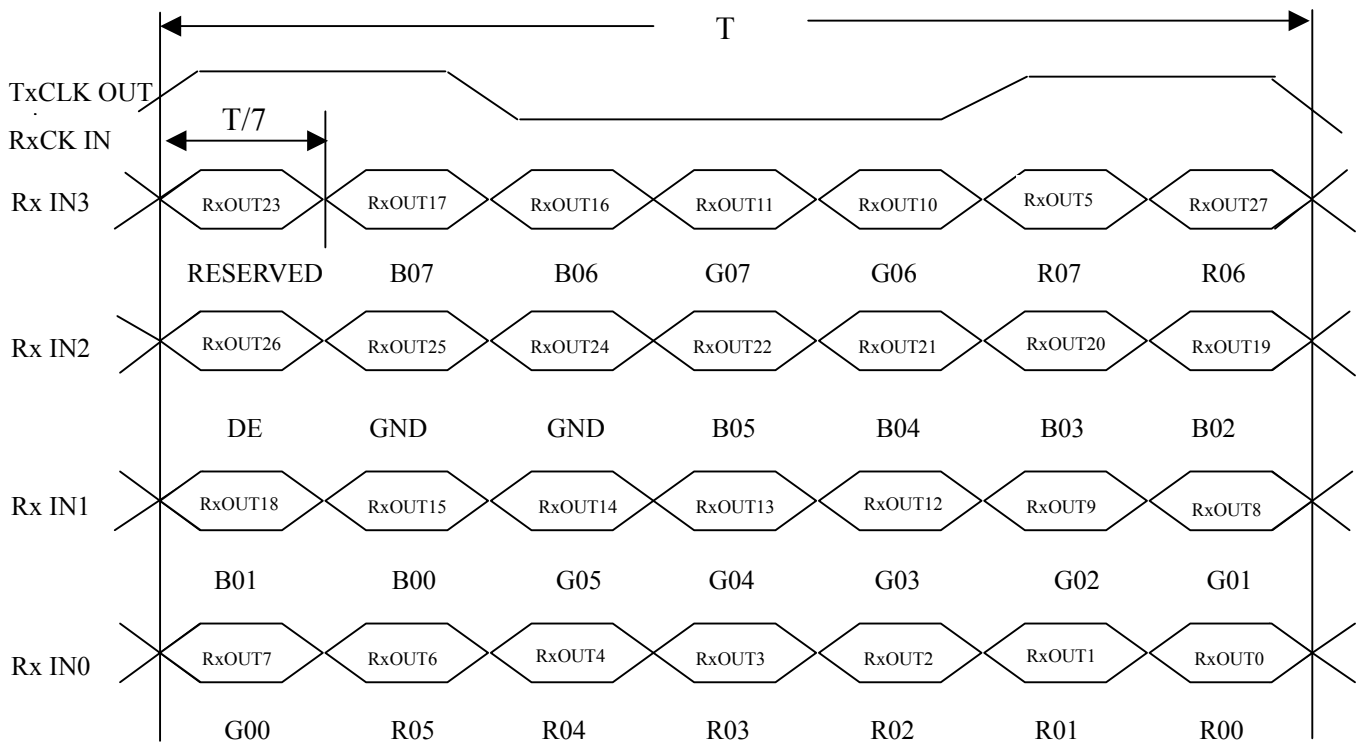

## 6.2 POWER ON/OFF SEQUENCE

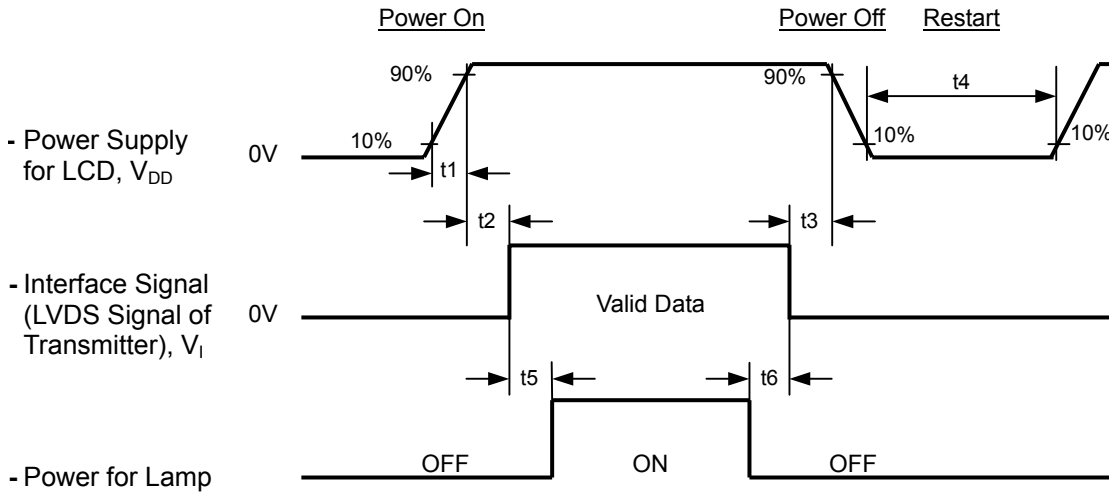

### Timing Specifications:

$$0 < t_1 \leq 10 \text{ msec}$$

$$0 < t_2 \leq 50 \text{ msec}$$

$$0 < t_3 \leq 50 \text{ msec}$$

$$t_4 \geq 1 \text{ sec}$$

$$t_5 \geq 100 \text{ msec}$$

$$t_6 \geq 100 \text{ msec}$$

Note (1) Please avoid floating state of interface signal at invalid period.

Note (2) When the interface signal is invalid, be sure to pull down the power supply of LCD  $V_{DD}$  to 0 V.

Note (3) The Backlight inverter power must be turned on after the power supply for the logic and the interface signal is valid. The Backlight inverter power must be turned off before the power supply for the logic and the interface signal is invalid.



## 7. OPTICAL CHARACTERISTICS

### 7.1 TEST CONDITIONS

Item	Symbol	Value	Unit
Ambient Temperature	T <sub>a</sub>	25±2	°C
Ambient Humidity	H <sub>a</sub>	50±10	%RH
Supply Voltage	V <sub>DD</sub>	3.3	V
Input Signal	According to typical value in "3. ELECTRICAL CHARACTERISTICS"		
Inverter Current	I <sub>L</sub>	8.0	mA

The measurement methods of optical characteristics are shown in Section 7.2. The following items should be measured under the test conditions described in Section 7.1 and stable environment shown in Note (4).

### 7.2 OPTICAL SPECIFICATIONS

Item		Symbol	Condition	Min.	Typ.	Max.	Unit	Note
Contrast Ratio		CR	$\theta_x=0^\circ, \theta_y=0^\circ$ Viewing Normal Angle	200	350	-	-	(2), (4)
Response Time		T <sub>R</sub>		-	6	10	ms	(3)
		T <sub>F</sub>		-	17	25	ms	
Luminance of White (Center point)		L		200	250	-	cd/m <sup>2</sup>	(4),(5)
White Variation		$\delta W$		-	1.25	1.40	-	(4),(5)
Color Chromaticity	Red	R <sub>x</sub>		0.603	0.633	0.663	-	(1), (4)
		R <sub>y</sub>		0.327	0.357	0.387	-	
	Green	G <sub>x</sub>		0.270	0.300	0.330	-	
		G <sub>y</sub>		0.556	0.586	0.616	-	
	Blue	B <sub>x</sub>		0.112	0.142	0.172	-	
		B <sub>y</sub>	0.064	0.094	0.124	-		
White	W <sub>x</sub>	0.283	0.313	0.343	-			
	W <sub>y</sub>	0.299	0.329	0.359	-			
Viewing Angle	Horizontal	$\theta_{x+}$	CR≥10	50	60	-	Deg.	
		$\theta_{x-}$		50	60	-		
	Vertical	$\theta_{y+}$		30	40	-		
		$\theta_{y-}$		50	60	-		

Note (1) Definition of Viewing Angle ( $\theta_x, \theta_y$ ):

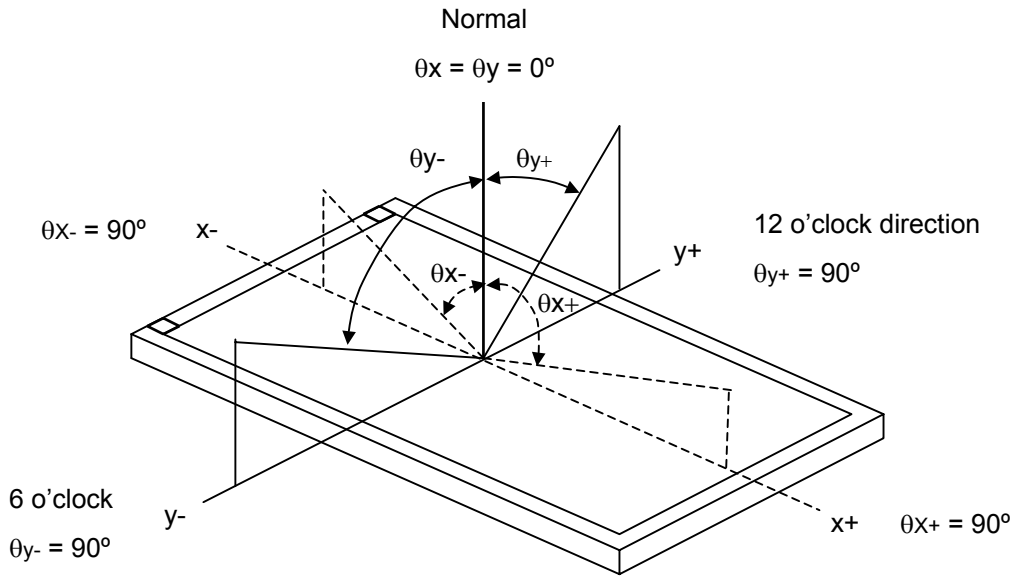

Note (2) Definition of Contrast Ratio (CR):

The contrast ratio can be calculated by the following expression.

$$\text{Contrast Ratio (CR)} = L_{255} / L_0$$

L255: Luminance of gray level 255

L 0: Luminance of gray level 0

$$CR = CR (1)$$

CR (X) is corresponding to the Contrast Ratio of the point X at Figure in Note (5).

Note (3) Definition of Response Time ( $T_R, T_F$ ):

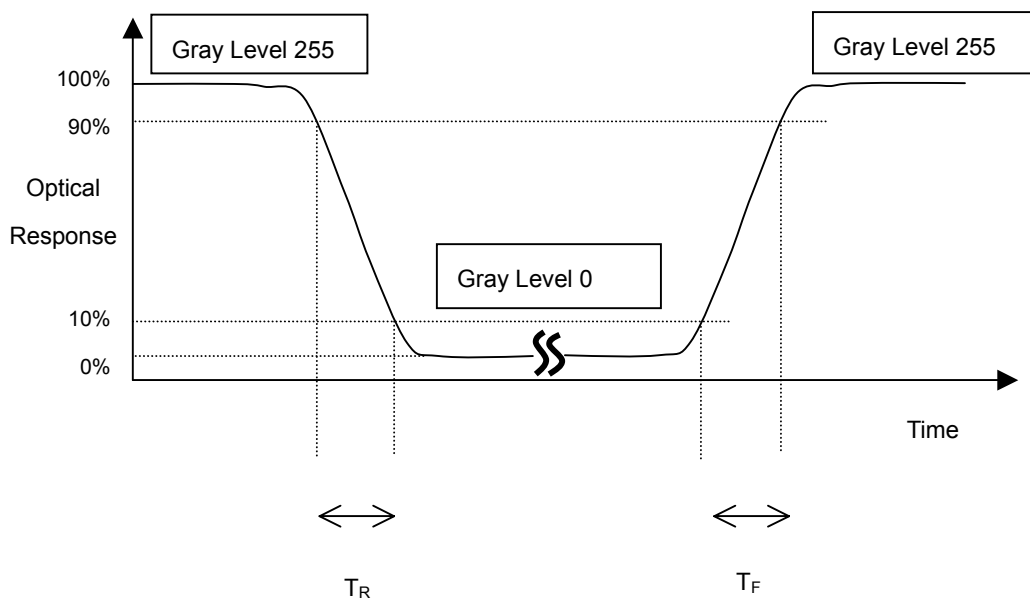

Note (4) Measurement Setup:

The LCD module should be stabilized at given temperature for 15 minutes to avoid abrupt temperature change during measuring. In order to stabilize the luminance, the measurement should be executed after lighting Backlight for 15 minutes in a windless room

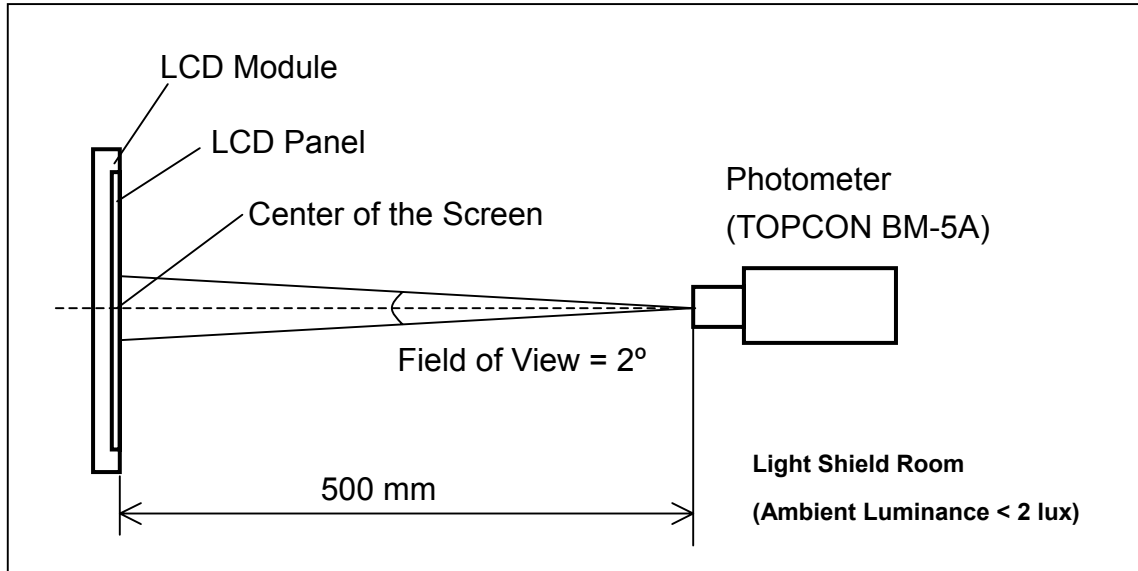

Note (5) Definition of luminance measured points:

Measure the luminance of gray level 255 at point L(1)

Definition of White Variation ( $\delta W$ ):

Measure the luminance of gray level 255 at 9 points

$$\delta W = \frac{\text{Maximum [L (1), L (6), L (7), L (8), L (9), L (10), L (11), L (12), L (13)]}}{\text{Minimum [L (1), L (6), L (7), L (8), L (9), L (10), L (11), L (12), L (13)]}}$$

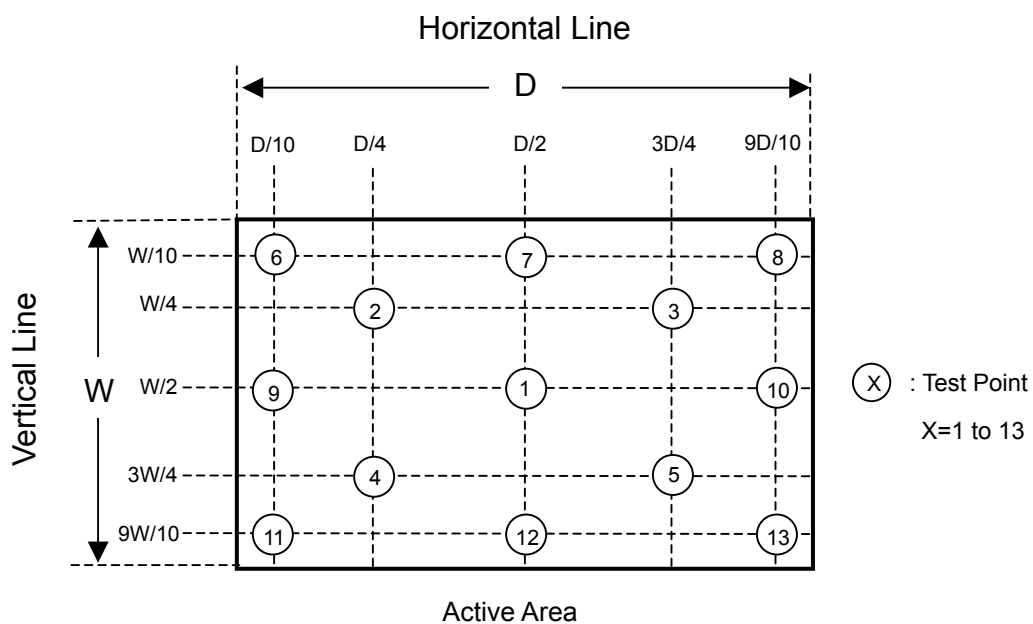

## 8. PRECAUTIONS

### 8.1 HANDLING PRECAUTIONS

- (1) The module should be assembled into the system firmly by using every mounting hole. Be careful not to twist or bend the module.
- (2) While assembling or installing modules, it can only be in the clean area. The dust and oil may cause electrical short or damage the polarizer.
- (3) Use fingerstalls or soft gloves in order to keep display clean during the incoming inspection and assembly process.
- (4) Do not press or scratch the surface harder than a HB pencil lead on the panel because the polarizer is very soft and easily scratched.
- (5) If the surface of the polarizer is dirty, please clean it by some absorbent cotton or soft cloth. Do not use Ketone type materials (ex. Acetone), Ethyl alcohol, Toluene, Ethyl acid or Methyl chloride. It might permanently damage the polarizer due to chemical reaction.
- (6) Wipe off water droplets or oil immediately. Staining and discoloration may occur if they left on panel for a long time.
- (7) If the liquid crystal material leaks from the panel, it should be kept away from the eyes or mouth. In case of contacting with hands, legs or clothes, it must be washed away thoroughly with soap.
- (8) Protect the module from static electricity, it may cause damage to the C-MOS Gate Array IC.
- (9) Do not disassemble the module.
- (10) Do not pull or fold the lamp wire.
- (11) Pins of I/F connector should not be touched directly with bare hands.

### 8.2 STORAGE PRECAUTIONS

- (1) High temperature or humidity may reduce the performance of module. Please store LCD module within the specified storage conditions.
- (2) It is dangerous that moisture come into or contacted the LCD module, because the moisture may damage LCD module when it is operating.
- (3) It may reduce the display quality if the ambient temperature is lower than 10 °C. For example, the response time will become slowly, and the starting voltage of lamp will be higher than the room temperature.

### 8.3 OPERATION PRECAUTIONS

- (1) Do not pull the I/F connector in or out while the module is operating.
- (2) Always follow the correct power on/off sequence when LCD module is connecting and operating. This can prevent the CMOS LSI chips from damage during latch-up.
- (3) The startup voltage of Backlight is approximately 1000 Volts. It may cause electrical shock while assembling with inverter. Do not disassemble the module or insert anything into the Backlight unit.

## 9. PACKAGING

### 9.1 PACKING SPECIFICATIONS

- (1) 10 LCD modules / 1 Box
- (2) Box dimensions : 511(L) X 420(W) X 360(H) mm
- (3) Weight : approximately 11Kg ( 10 modules per box)

### 9.2 PACKING Method

Figures 9-1 and 9-2 are the packing method.

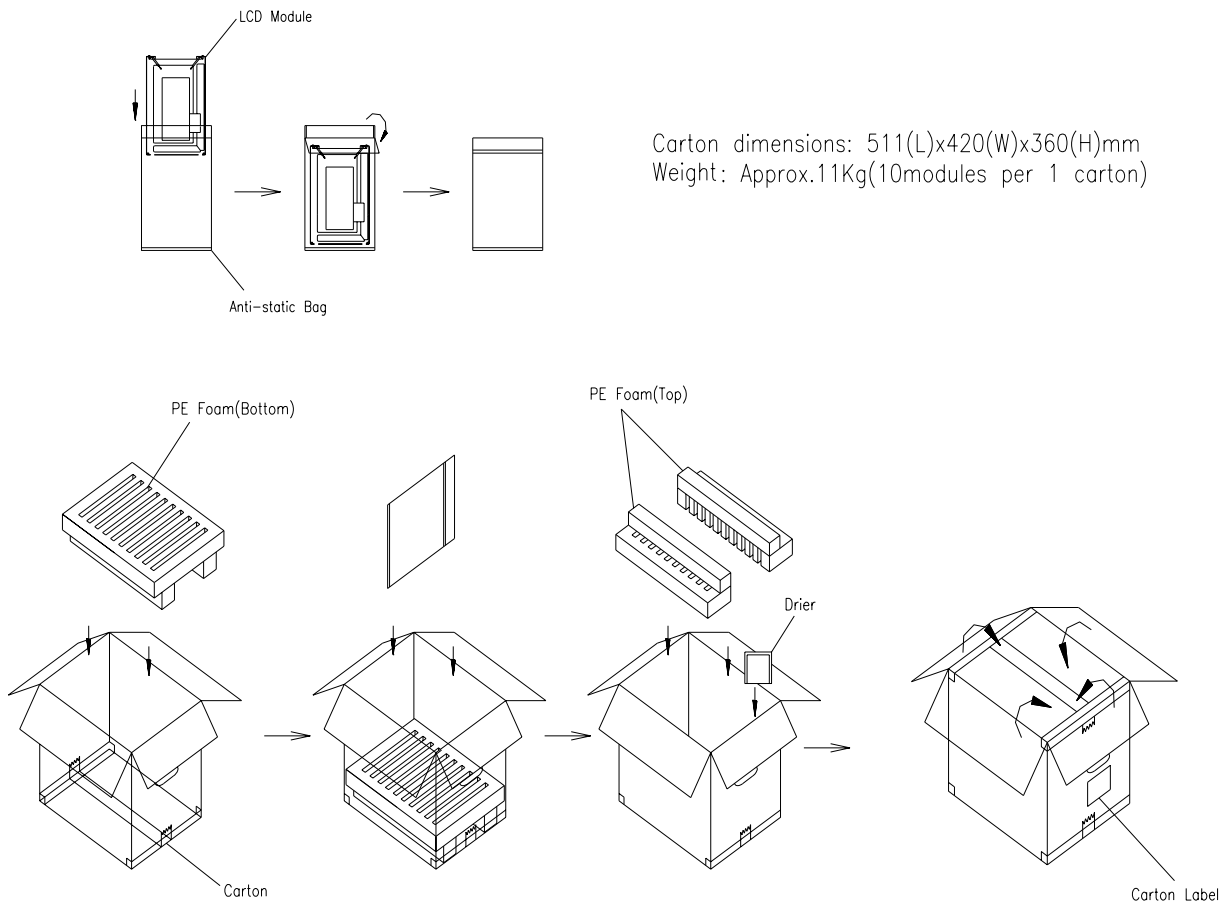

Figure. 9-1 Packing method

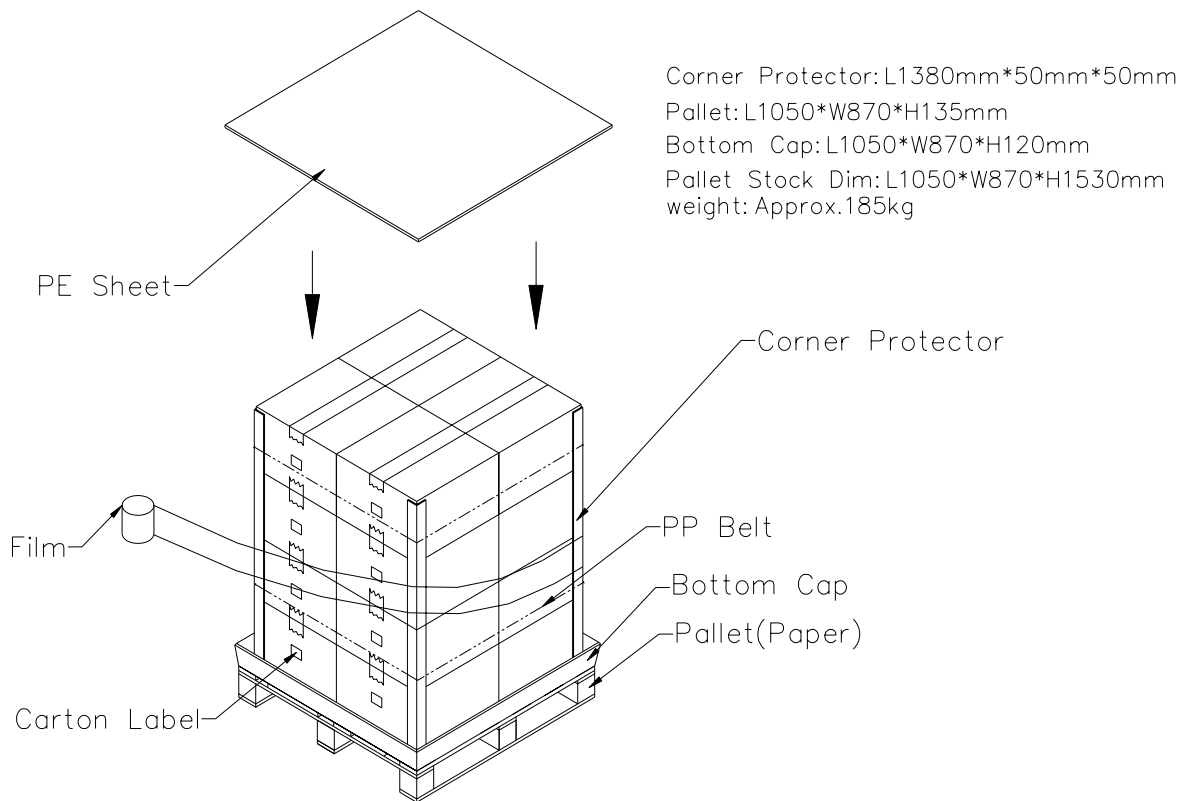

Figure. 9-2 Packing method

## 10. INCOMING INSPECTION DAY

The Supplier should be acquainted the inspection results (acceptance or rejection) by Customer, and the results are in accordance with the incoming inspection standard within 30 days after the date of the bills of lading.

Should Customer fail to so notify the Supplier within the said 30 days period. The Customer's right to reject the LCMS shall then lapse, and the said LCMS shall be deemed to have been accepted by the customer.

## 11. DEFINITION OF LABELS

### 11.1 CMO MODULE LABEL

The barcode nameplate is pasted on each module as illustration, and its definitions are as following explanation.

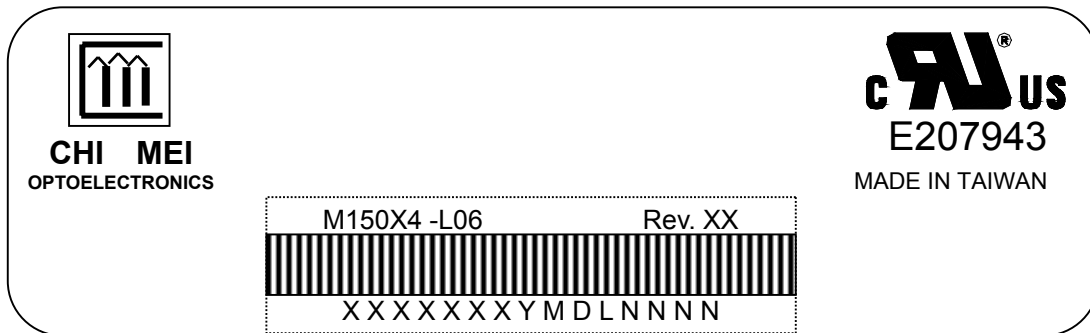

- (a) Model Name: M150X4 –L06
- (b) Revision: Rev. XX, for example: C1, C2 ...etc.
- (c) Serial ID: X X X X X X Y M D L N N N N

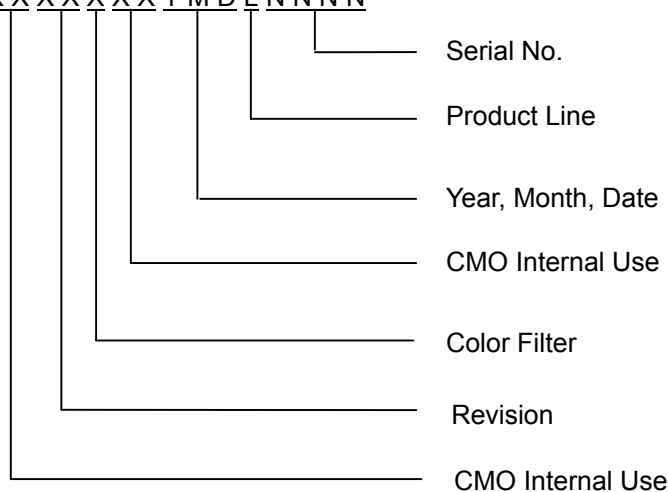

Serial ID includes the information as below:

- (a) Manufactured Date: Year: 1~9, for 2000~2009  
 Month: 1~9, A~C, for Jan. ~ Dec.  
 Day: 1~9, A~Y, for 1<sup>st</sup> to 31<sup>st</sup>, exclude I and O
- (b) Revision Code: cover all the change
- (c) Color Filter: 0 ->CMO, 2 -> Toppan
- (d) Serial No.: Manufacturing sequence of product
- (e) Product Line: 1 -> Line1, 2 -> Line 2, ...etc.



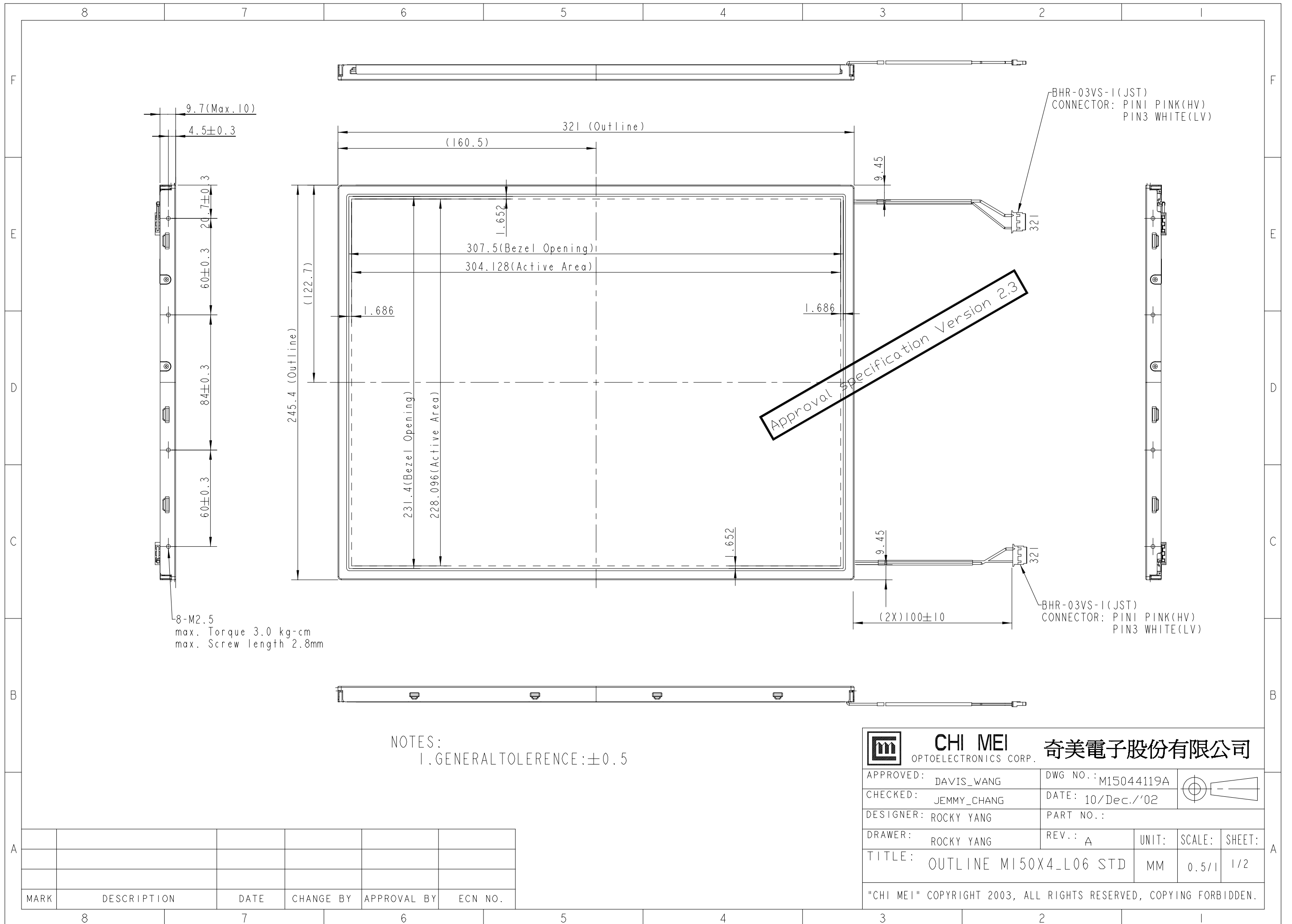

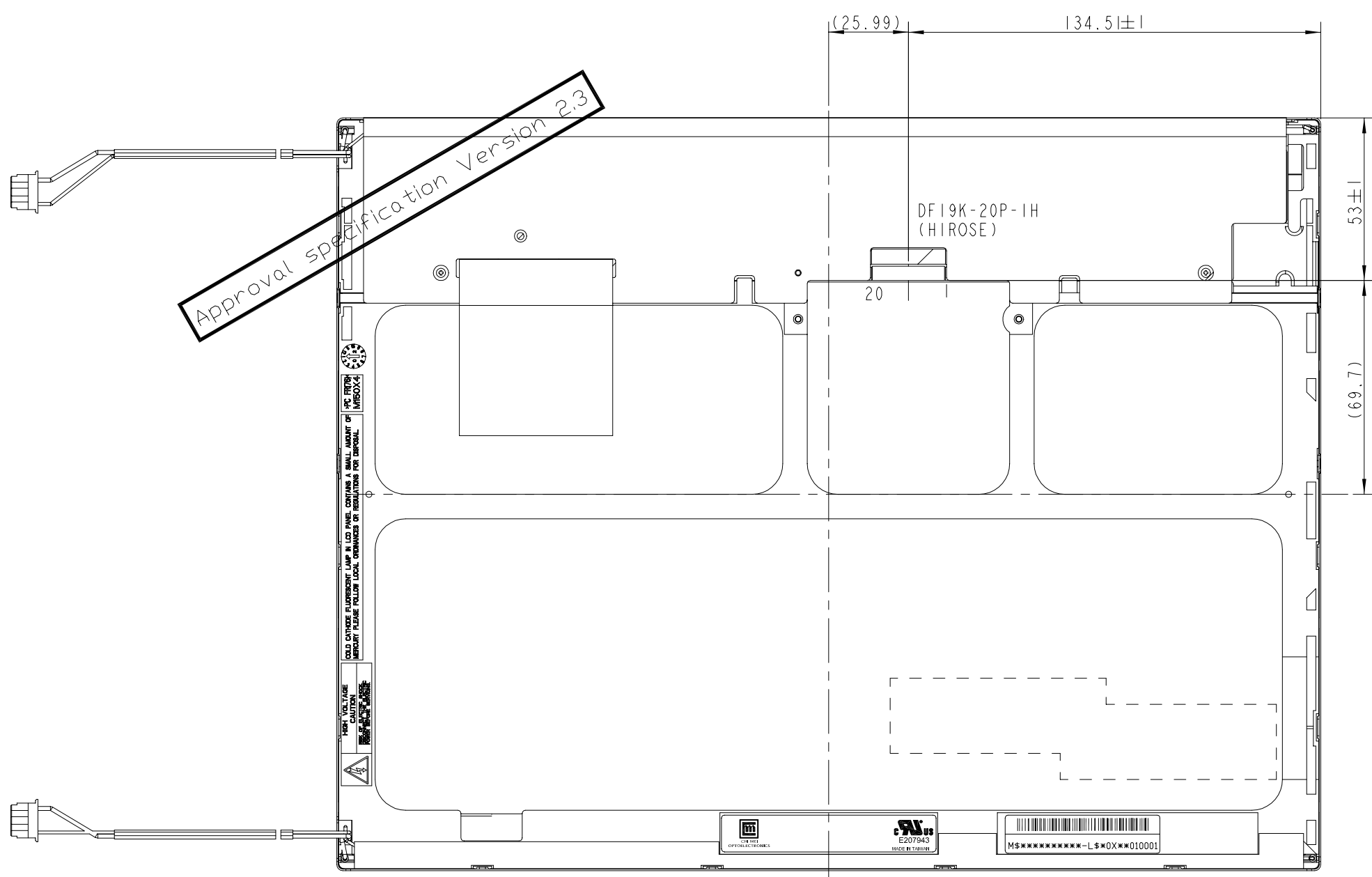

NOTES:  
1. GENERAL TOLERANCE: ±0.5

<b>CHI MEI</b> 奇美電子股份有限公司 OPTOELECTRONICS CORP.	
APPROVED: DAVIS_WANG	DWG NO.: M15044119A
CHECKED: JEMMY_CHANG	DATE: 10/Dec./'02
DESIGNER: ROCKY YANG	PART NO.:
DRAWER: ROCKY YANG	REV.: A
TITLE: OUTLINE M150X4-L06 STD	UNIT: MM
	SCALE: 0.6/1
	SHEET: 2/2
"CHI MEI" COPYRIGHT 2002, ALL RIGHTS RESERVED, COPYING FORBIDDEN.	

MARK	DESCRIPTION	DATE	CHANGE BY	APPROVAL BY	ECN NO.