

Released

S-band Magnetron

Model No. M1556

Copyright©**Nisshinbo Micro Devices Inc.
Microwave Business Headquarters**

-Notice of Proprietary Information-

This document and its contents are proprietary to Nisshinbo Micro Devices Inc.
This publication and its contents may not be reproduced or distributed for any other purpose
without the written permission of Nisshinbo Micro Devices Inc.
Those specifications listed in this document are subject to change at any time.

■ GENERAL DESCRIPTION

M1556 is designed for the magnetron of S-band radar system. The frequency range is fixed <3025 - 3075MHz> and the peak output power is 60 kW.

【V Technology】

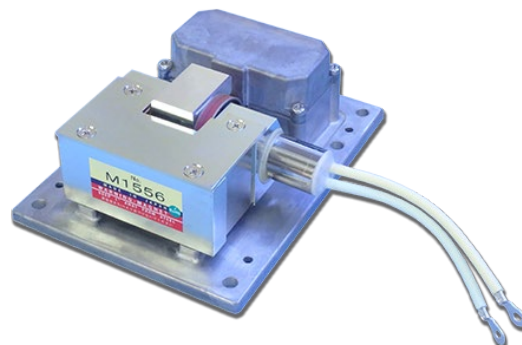

■ ELECTRICAL CHARACTERISTICS

PARAMETERS	MINIMUM	TYPICAL	MAXIMUM	UNITS
Heater voltage (note 1)	5.7	6.3	6.9	V
Heater current	1.1	1.3	1.4	A
Preheat time	180	-	-	s
Peak anode voltage (note 2)	8.5	9.0	9.5	kV
Peak output power (note 2)	55	60	-	kW
Frequency (note 2)	3025	3055	3075	MHz

■ ABSOLUTE MAXIMUM RATINGS

These ratings cannot necessarily be used simultaneously and no individual ratings should be exceeded.

PARAMETERS	MINIMUM	MAXIMUM	UNITS
Peak anode current (note 3)	10.0	17.0	A
Peak anode power input	-	150	kW
Duty cycle	-	0.001	-
Pulse duration	0.07	1.0	μs
Rate of rise of voltage pulse	-	130	kV/μs
Anode temperature	-	120	°C
VSWR at the output coupler	-	1.5 : 1	-

* Above Specifications are subject to change without notice.

Notes

1. With no anode input power. For average pulse input powers greater than 25 watts, the heater voltage must be reduced within 3 seconds after the application of h.t. according to the following schedule:

Mean input power (W)	Heater Voltage (V)
Less than 28	6.3
28 to 83	5.0
83 to 130	3.8
130 to 150	3.0

2. Measured at peak anode current 8.0A.
3. Any overshoot of the anode current is not acceptable. The impedance of this magnetron is the same as current magnetron excluding the transient impedance. This means that the additional reactance should be required for adjustment the anode current wave form, if this magnetron will be installed into the similar modulator circuit as before.

* Above Specifications are subject to change without notice.

■ OUTLINE

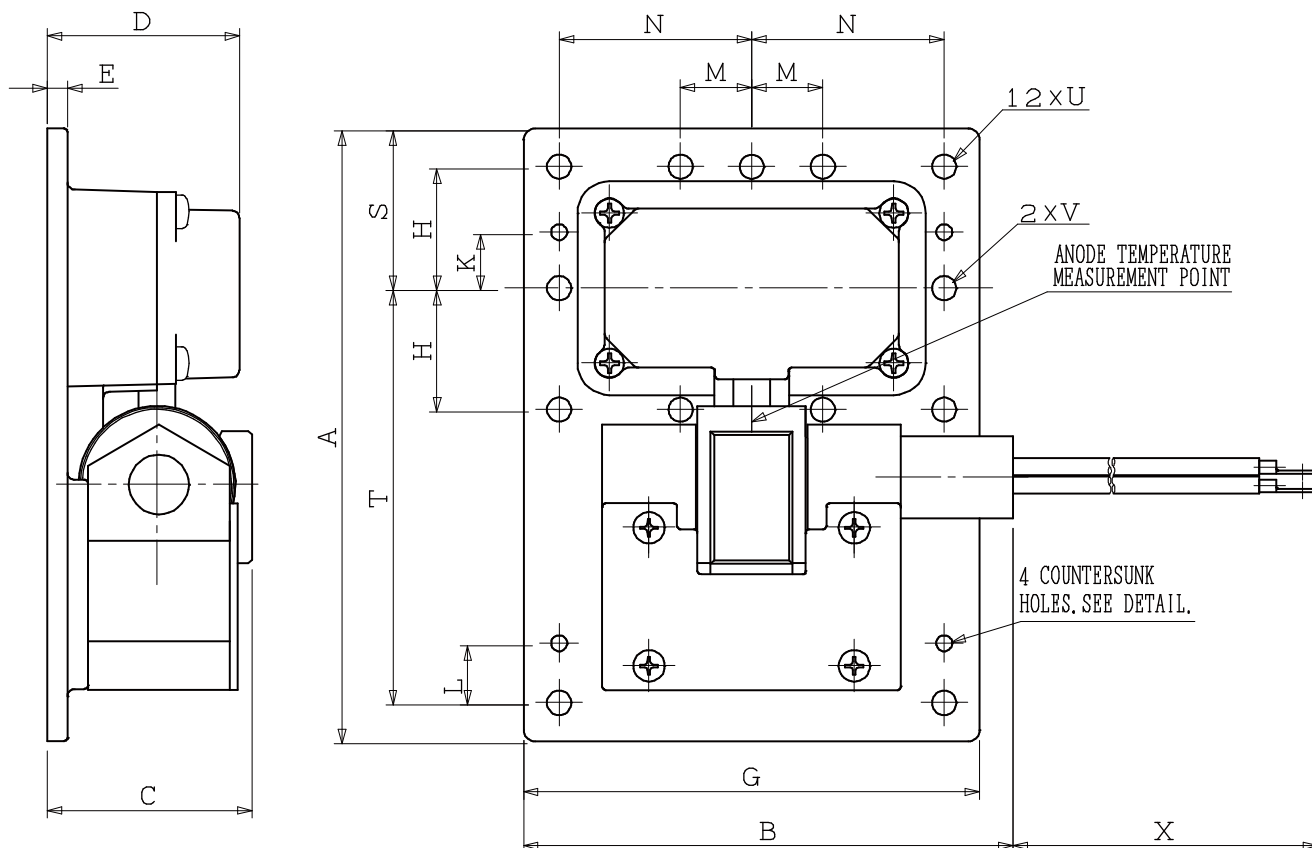

DEMENSIONS Unit:mm

A	165.1MAX	M	19.05±0.05
B	150MAX	N	51.6±0.1
C	72MAX	P	---
D	55MAX	R	---
E	5.5	S	42.7
F	---	T	111.1
G	123.2MAX	U	φ6.5±0.1
H	32.54	V	φ6.5±0.05
J	---	W	---
K	15	X	110MIN
L	16		

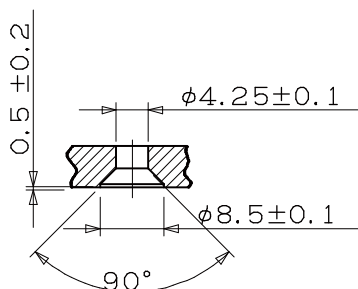
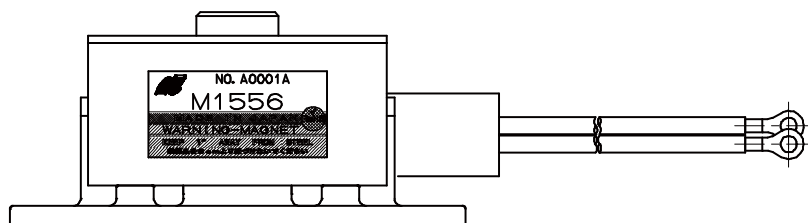

DETAIL OF COUNTERSUNK HOLES

* Above Specifications are subject to change without notice.

