

## TFT LCD Approval Specification

# MODEL NO.: M156B3-LA1

Customer: \_\_\_\_\_

Approved by: \_\_\_\_\_

Note:

[www.jxlcd.com](http://www.jxlcd.com)

核准時間	部門	審核	角色	投票
2010-07-28 09:50:04	MTR 產品管理處	吳 2010.07.28 柏勳	Director	Accept

- CONTENTS -

REVISION HISTORY.....	3
1. GENERAL DESCRIPTION .....	4
1.1 OVERVIEW	
1.2 FEATURES	
1.3 APPLICATION	
1.4 GENERAL SPECIFICATIONS	
1.5 MECHANICAL SPECIFICATIONS	
2. ABSOLUTE MAXIMUM RATINGS .....	5
2.1 ABSOLUTE RATINGS OF ENVIRONMENT	
2.2 ELECTRICAL ABSOLUTE RATINGS	
2.2.1 TFT LCD MODULE	
3. ELECTRICAL CHARACTERISTICS .....	7
3.1 TFT LCD MODULE	
3.2 V <sub>CC</sub> POWER DIP CONDITION	
3.3 BACKLIGHT UNIT	
4. BLOCK DIAGRAM .....	11
4.1 TFT LCD MODULE	
4.2 BACKLIGHT UNIT	
5. INPUT TERMINAL PIN ASSIGNMENT .....	12
5.1 TFT LCD MODULE	
5.2 LVDS DATA MAPPING TABLE	
5.3 BACKLIGHT SPECIFICATION	
5.3.1 Connector type	
5.3.2 Input connector pin assignment	
5.4 COLOR DATA INPUT ASSIGNMENT	
6. INTERFACE TIMING .....	14
6.1 INPUT SIGNAL TIMING SPECIFICATIONS	
6.2 POWER ON/OFF SEQUENCE	
7. OPTICAL CHARACTERISTICS .....	17
7.1 TEST CONDITIONS	
7.2 OPTICAL SPECIFICATIONS	
8. PACKAGING .....	20
8.1 PACKING SPECIFICATIONS	
8.2 PACKING METHOD	
9. DEFINITION OF LABELS .....	22
9.1 CMO MODULE LABEL	
10. RELIABILITY TEST .....	23
11. PRECAUTIONS .....	24
11.1 ASSEMBLY AND HANDLING PRECAUTIONS	
11.2 SAFETY PRECAUTIONS	
11.3 SAFETY STANDARDS	
11.4 STORAGE	
11.5 OPERATION CONDITION GUIDE	
11.6 OTHER	
12. MECHANICAL CHARACTERISTICS .....	25

**REVISION HISTORY**

	<b>Date</b>	<b>Section</b>	<b>Description</b>
Ver. 2.0	Mar.29, 10	-	M156B3-LA1 Approval Specifications was first issued.
Ver. 2.1	Jul. 15, 10	3.4.2	Revise the comments of Input connector pin assignment.

[www.jxlcd.com](http://www.jxlcd.com)

## 1. GENERAL DESCRIPTION

### 1.1 OVERVIEW

M156B3-LA1 is a 15.6" wide TFT Liquid Crystal Display module with white LED Backlight unit and 30 pins 1ch-LVDS interface. This module supports 1366 x 768 WXGA mode and can display 16.7M colors.

The converter module for Backlight is not built in.

### 1.2 FEATURES

- Contrast ratio 500:1
- Response time 8ms.
- WXGA (1366 x 768 pixels) resolution.
- DE (Data Enable) only mode.
- LVDS (Low Voltage Differential Signaling) interface.
- RoHS compliance.
- White LED Backlight Unit
- Low power consumption

### 1.3 APPLICATION

- TFT LCD Monitor

[www.jxlcd.com](http://www.jxlcd.com)

### 1.4 GENERAL SPECIFICATIONS

Item	Specification	Unit	Note
Active Area	344.232(H) × 193.536(V) (15.6" diagonal)	mm	(1)
Bezel Opening Area	347.5(H)x196.8(V)	mm	
Driver Element	a-si TFT active matrix	-	-
Pixel Number	1366 x R.G.B. x 768	pixel	-
Pixel Pitch	0.252 (H) x 0.252 (V)	mm	-
Pixel Arrangement	RGB vertical stripe	-	-
Display Colors	16.7M	color	-
Color saturation	65 %NTSC (typ.)	-	-
Surface Treatment	AG type, 3H hard coating, Haze 25	-	-
Module Power Consumption	8.002	Watt	(2)

### 1.5 MECHANICAL SPECIFICATIONS

Item	Min.	Typ.	Max.	Unit	Note	
Module Size	Horizontal(H)	363.3	363.8	364.3	mm	(1)
	Vertical(V)	215.4	215.9	216.4	mm	
	Depth(D)	10.4	10.9	11.6	mm	
Weight	-	1061	1081	g	-	
I/F connector mounting position	The mounting inclination of the connector makes the screen center within ±0.5 mm as the horizontal.					

Note (1) Please refer to the attached drawings for more information of front and back outline dimensions.

Note (2) Please refer to the section 3.1 & 3.2 & 3.3 for more information of power consumption.

## 2. ABSOLUTE MAXIMUM RATINGS

### 2.1 ABSOLUTE RATINGS OF ENVIRONMENT

Item	Symbol	Value		Unit	Note
		Min.	Max.		
Storage Temperature	T <sub>ST</sub>	-20	+60	°C	(1)
Operating Ambient Temperature	T <sub>OP</sub>	0	+50	°C	(1), (2)
Shock (Non-Operating)	S <sub>NOP</sub>	-	50	G	(3), (5)
Vibration (Non-Operating)	V <sub>NOP</sub>	-	1.5	G	(4), (5)

Note (1) Temperature and relative humidity range is shown in the figure below.

- (a) 90 %RH Max. (Ta ≤ 40 °C).
- (b) Wet-bulb temperature should be 39 °C Max. (Ta > 40 °C).
- (c) No condensation.

Note (2) The temperature of panel display surface area should be 0 °C Min. and 60 °C Max.

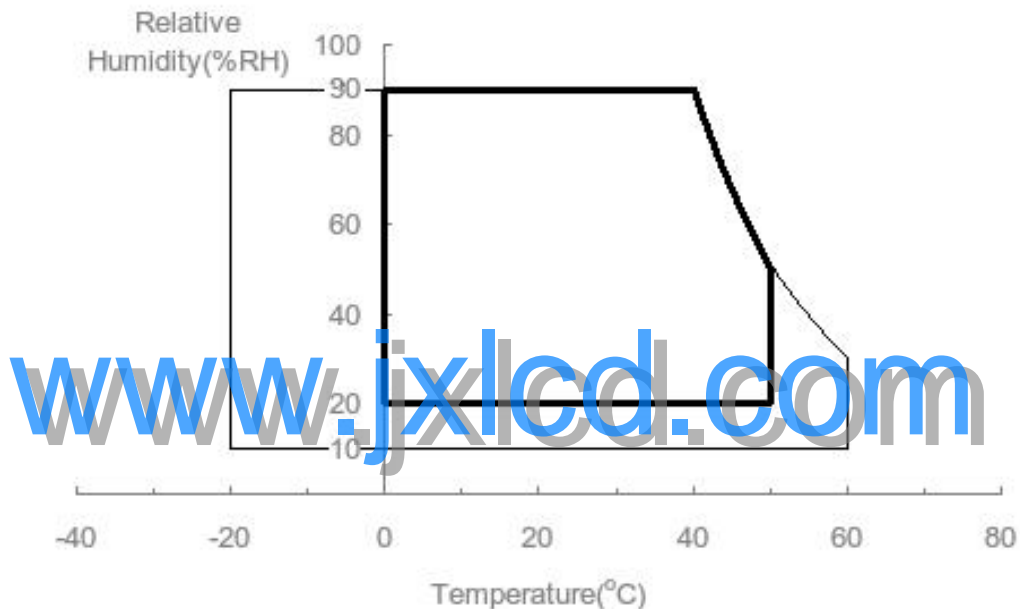

Note (3) 50G,11ms, half sine wave, 1 time for ± X, ± Y, ± Z.

Note (4) 10 ~ 300 Hz, 10min/cycle, 3 cycles each X, Y, Z.

Note (5) At testing Vibration and Shock, the fixture in holding the module has to be hard and rigid enough so that the module would not be twisted or bent by the fixture.

At Room Temperature

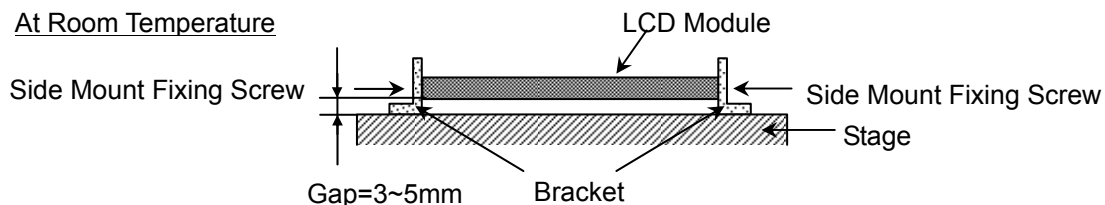

## 2.2 ELECTRICAL ABSOLUTE RATINGS

### 2.2.1 TFT LCD MODULE

Item	Symbol	Value		Unit	Note
		Min.	Max.		
Power Supply Voltage	Vcc	-0.3	+6.0	V	(1)
Logic Input Voltage	Vlogic	-0.3	+2.8	V	

Note (1) Permanent damage might occur if the module is operated at conditions exceeding the maximum values.

### 2.2.2 BACK LIGHT UNIT

Item	Symbol	Value			Unit	Note
		Min.	Typ.	Max.		
LED Forward Current Per Input Pin	I <sub>F</sub>	0	20	30	mA	(1), (2) Duty=100%
LED Reverse Voltage Per Input Pin	V <sub>R</sub>	---	---	60	V	
LED Plus Forward Current Per Input Pin	IP	---	---	80	mA	(1), (2) Plus Width 10msec , And Duty 10%

Note (1) Permanent damage to the device may occur if maximum values are exceeded. Function operation should be restricted to the conditions described under Normal Operating Conditions.

Note (2) Specified values are for input pin of LED light bar at Ta=25±2 (Refer to 3.2 and 3.3 for further information).

[www.jxlcd.com](http://www.jxlcd.com)

### 3. ELECTRICAL CHARACTERISTICS

#### 3.1 TFT LCD MODULE

Ta = 25 ± 2 °C

Parameter	Symbol	Value			Unit	Note
		Min.	Typ.	Max.		
Power Supply Voltage	V <sub>CC</sub>	4.5	5.0	5.5	V	-
Ripple Voltage	V <sub>RP</sub>	-	-	100	mV	-
Rush Current	I <sub>RUSH</sub>	-	0.84	2	A	(2)
Power Supply Current	White	-	0.31	0.37	A	(3)a
	Black	-	0.38	0.46	A	(3)b
	Vertical Stripe	-	0.41	0.5	A	(3)c
Power Consumption	P <sub>LCD</sub>	-	2.05	2.5	watt	(4)
LVDS differential input voltage	V <sub>id</sub>	200	-	600	mV	(5)
LVDS common input voltage	V <sub>ic</sub>	-	0.8	-	V	

Note (1) The module should be always operated within above ranges.

Note (2) Measurement Conditions:

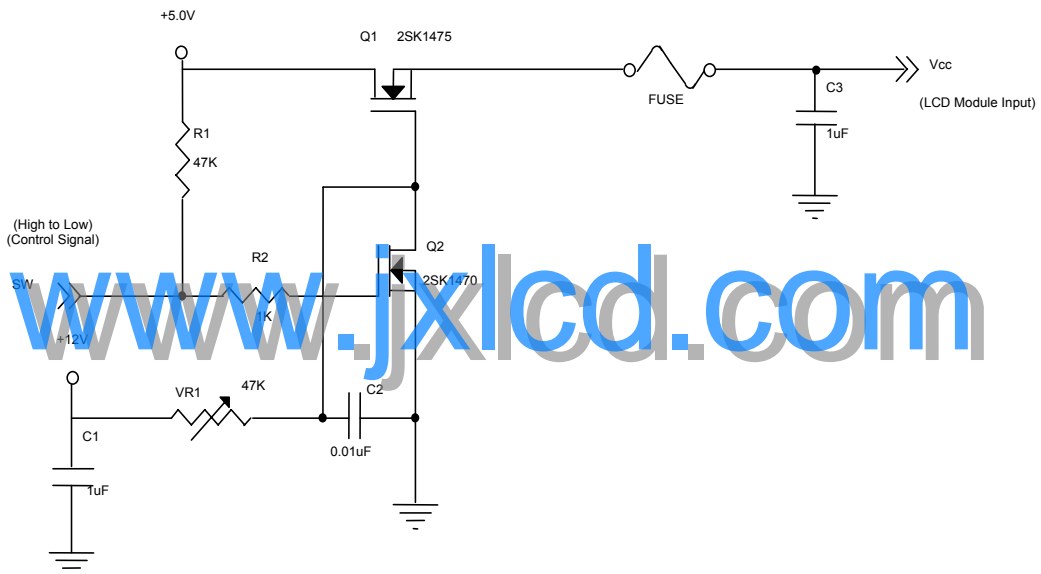

**Vcc rising time is 470μs**

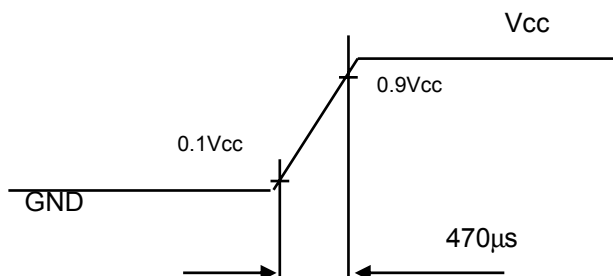

Note (3) The specified power supply current is under the conditions at  $V_{CC} = 5.0\text{ V}$ ,  $T_a = 25 \pm 2\text{ }^\circ\text{C}$ ,  $f_v = 60\text{ Hz}$ , whereas a power dissipation check pattern below is displayed.

a. White Pattern



Active Area

b. Black Pattern



Active Area

c. Vertical Stripe Pattern

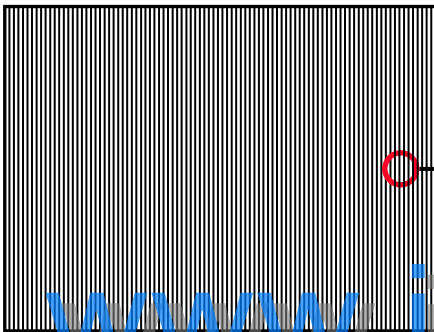

Active Area

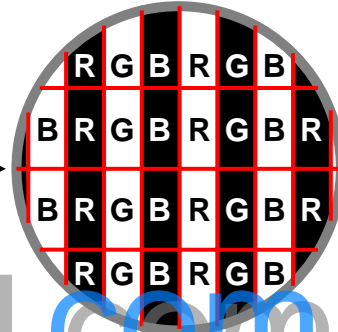

[www.jxlcd.com](http://www.jxlcd.com)

Note(4) The power consumption is specified at the pattern with the maximum current.

Note (5) VID waveform condition:

Single-End

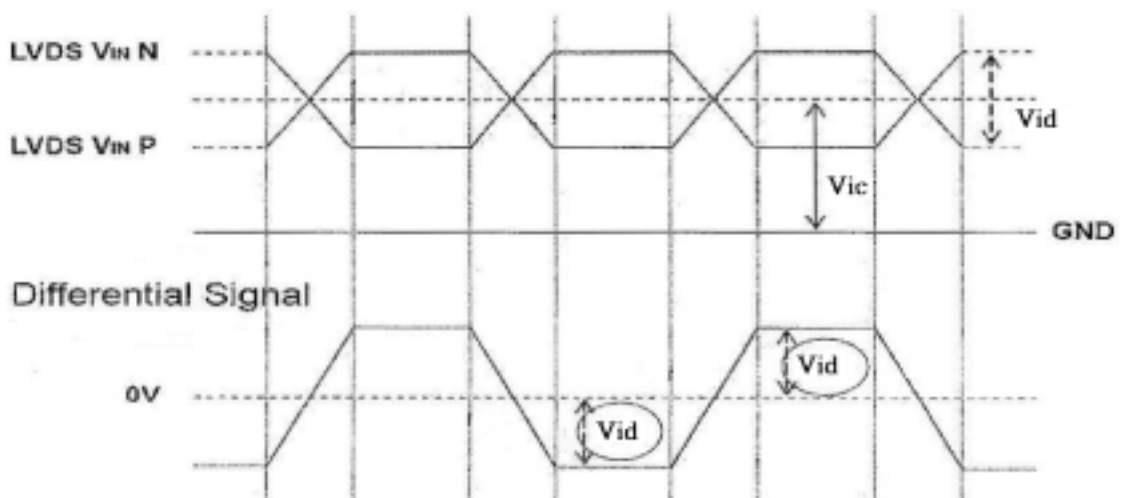



### 3.2 Vcc Power Dip Condition:

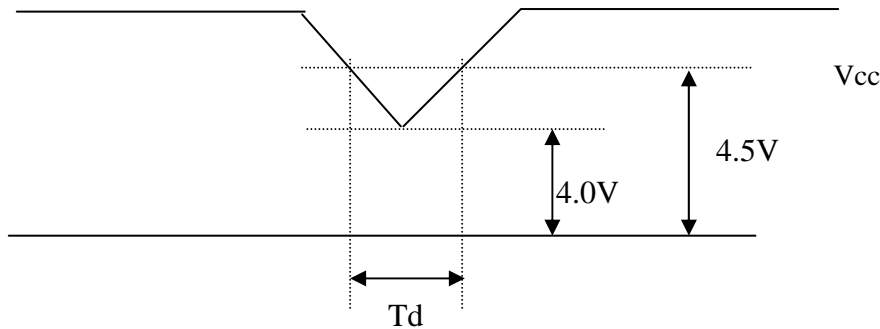

Dip condition:  $4.0V \leq V_{cc} \leq 4.5V, T_d \leq 20ms$

### 3.3 BACKLIGHT UNIT

$T_a = 25 \pm 2 \text{ } ^\circ\text{C}$

Parameter	Symbol	Value			Unit	Note
		Min.	Typ.	Max.		
LED light bar Input Voltage	$V_o$	33.6	37.2	40.8	$V_{DC}$	(1), Duty=100%, $I_{PIN}=20mA$
LED light bar Lamp Current	$I_{pin}$	---	20	30	$mA_{DC}$	(1), (2) Duty=100%
LED Life Time	$t_{BL}$	25000	30000	---	Hrs	(3)
Power Consumption	$P_o$	---	5.952	---	W	(1) Duty=100%, $I_{PIN}=20mA$

Note (1) LED light bar input voltage and current are measured by utilizing a true RMS multimeter as shown below:

Note (2)  $P_{BL} = I_{PIN} \times V_{PIN} \times 8$  input pins , LED light bar circuit is 12 Series, 8 Parallel.

Note (3) The lifetime of LED is defined as the time when LED packages continue to operate under the conditions at  $T_a = 25 \pm 2$  and  $I = 20mA$  (per chip) until the brightness becomes 50% of its original value.

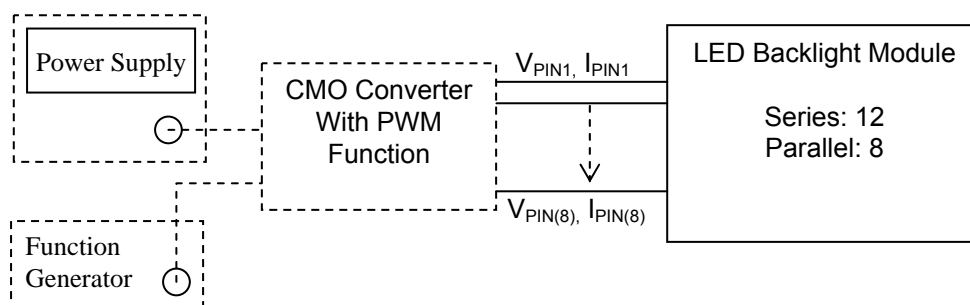

### 3.4 LIGHTBAR Connector Pin Assignment

#### 3.4.1 Connector type

Input connector: 7083K-F12N-00L (Entry)

#### 3.4.2 Input connector pin assignment: CN1

Input connector pin assignment: CN1

Input connector CN1		Comments
(vendor) (Entry)	(type) 7083K-F12N-00L	
Pin	Function	
1	LED1	LED1 negative polarity
2	LED2	LED2 negative polarity
3	LED3	LED3 negative polarity
4	LED4	LED4 negative polarity
5	NC	No connect
6	VLED (35V)	Input voltage Power Supply + (35V.typ)
7	VLED (35V)	Input voltage Power Supply + (35V.typ)
8	NC	No connect
9	LED5	LED5 negative polarity
10	LED6	LED6 negative polarity
11	LED7	LED7 negative polarity
12	LED8	LED8 negative polarity

## 4. BLOCK DIAGRAM

### 4.1 TFT LCD MODULE

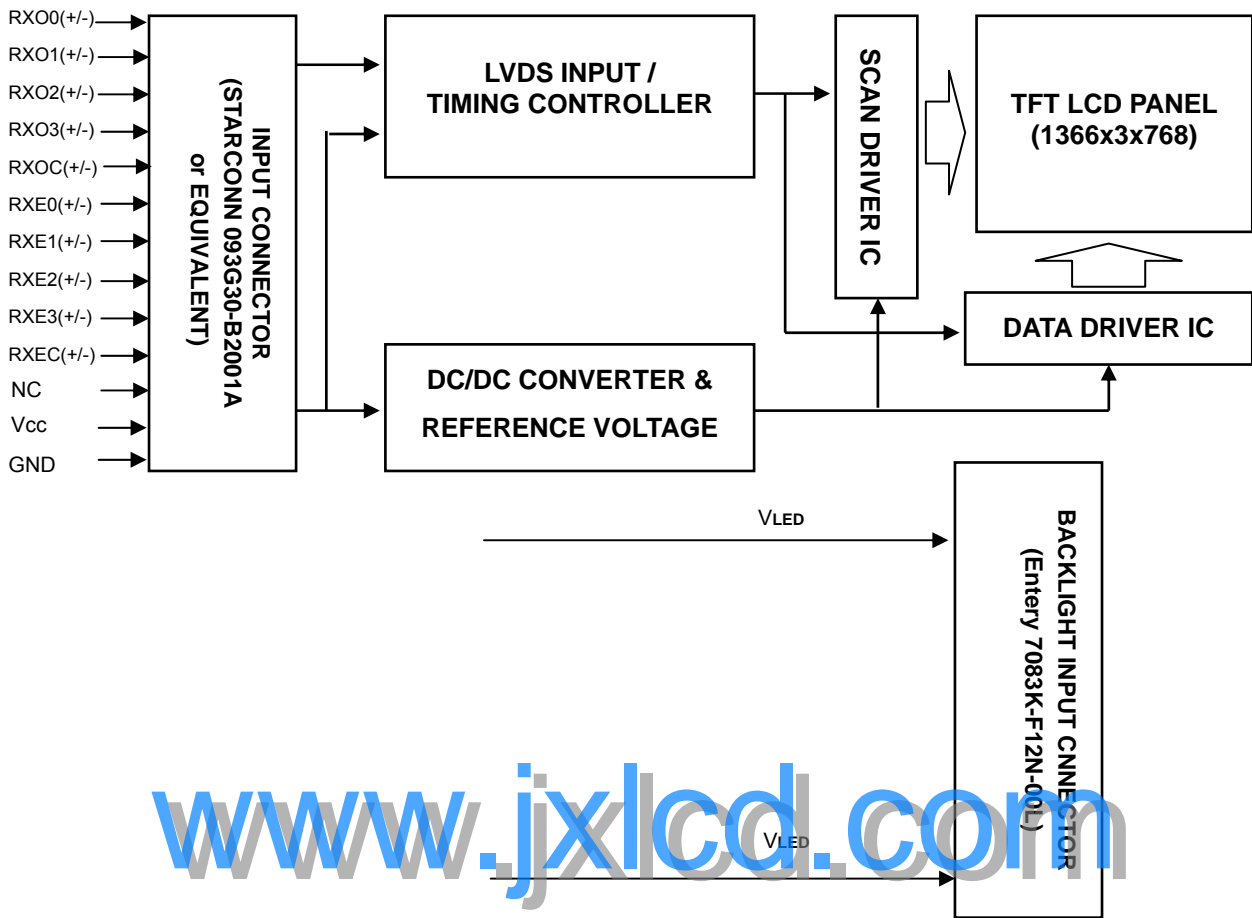

[www.jxlcd.com](http://www.jxlcd.com)

### 4.2 BACKLIGHT UNIT

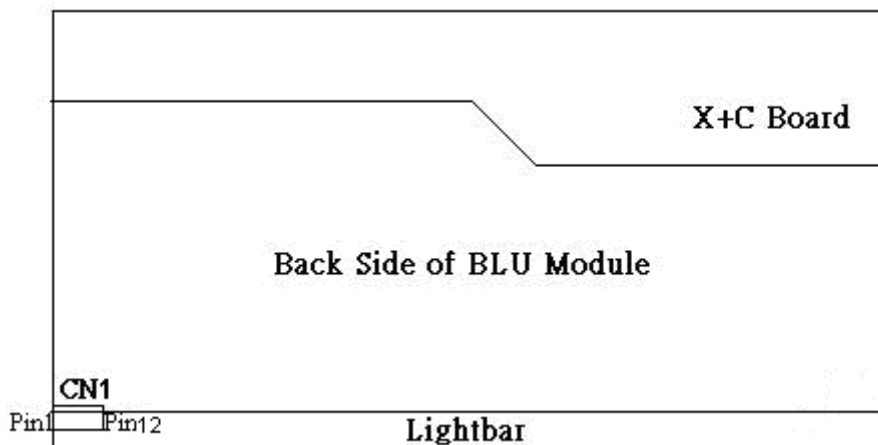

## 5. INPUT TERMINAL PIN ASSIGNMENT

### 5.1 TFT LCD MODULE

Pin	Name	Description
1	NC	Not connection, this pin should be open.
2	NC	Not connection, this pin should be open.
3	NC	Not connection, this pin should be open.
4	GND	Ground
5	RX0-	Negative LVDS differential data input. Channel 0
6	RX0+	Positive LVDS differential data input. Channel 0
7	GND	Ground
8	RX1-	Negative LVDS differential data input. Channel 1
9	RX1+	Positive LVDS differential data input. Channel 1
10	GND	Ground
11	RX2-	Negative LVDS differential data input. Channel 2
12	RX2+	Positive LVDS differential data input. Channel 2
13	GND	Ground
14	RXCLK-	Negative LVDS differential clock input.
15	RXCLK+	Positive LVDS differential clock input.
16	GND	Ground
17	RX3-	Negative LVDS differential data input. Channel 3
18	RX3+	Positive LVDS differential data input. Channel 3
19	GND	Ground
20	NC	Not connection, this pin should be open.
21	NC	Not connection, this pin should be open.
22	AGMODE	AGMODE should be tied to ground or open.
23	GND	Ground
24	GND	Ground
25	GND	Ground
26	Vcc	+5.0V power supply
27	Vcc	+5.0V power supply
28	Vcc	+5.0V power supply
29	Vcc	+5.0V power supply
30	Vcc	+5.0V power supply

Note (1) Connector Part No.: STARCONN 093G30-B2001A or equivalent

Note (2) Mating Wire Cable Connector Part No.: FI-X30H(JAE) or FI-X30HL(JAE)

Note (3) Mating FFC Cable Connector Part No.: 217007-013001 (P-TWO) or JF05X030-1 (JAE)

Note (4) The first pixel is odd.

Note (5) Input signal of even and odd clock should be the same timing.

### 5.2 LVDS DATA MAPPING TABLE

LVDS Channel 0	LVDS output	D7	D6	D4	D3	D2	D1	D0
	Data order	G0	R5	R4	R3	R2	R1	R0
LVDS Channel 1	LVDS output	D18	D15	D14	D13	D12	D9	D8
	Data order	B1	B0	G5	G4	G3	G2	G1
LVDS Channel 2	LVDS output	D26	D25	D24	D22	D21	D20	D19
	Data order	DE	NA	NA	B5	B4	B3	B2
LVDS Channel 3	LVDS output	D23	D17	D16	D11	D10	D5	D27
	Data order	NA	B7	B6	G7	G6	R7	R6

### 5.3 COLOR DATA INPUT ASSIGNMENT

The brightness of each primary color (red, green and blue) is based on the 8-bit gray scale data input for the color. The higher the binary input, the brighter the color. The table below provides the assignment of color versus data input.

Color		Data Signal																							
		Red								Green								Blue							
		R7	R6	R5	R4	R3	R2	R1	R0	R7	R6	G5	G4	G3	G2	G1	G0	R7	R6	B5	B4	B3	B2	B1	B0
Basic Colors	Black	0	0	0	0	0	0	0	0	0	0	0	0	0	0	0	0	0	0	0	0	0	0	0	0
	Red	1	1	1	1	1	1	1	1	0	0	0	0	0	0	0	0	0	0	0	0	0	0	0	0
	Green	0	0	0	0	0	0	0	0	1	1	1	1	1	1	1	1	0	0	0	0	0	0	0	0
	Blue	0	0	0	0	0	0	0	0	0	0	0	0	0	0	0	0	1	1	1	1	1	1	1	1
	Cyan	0	0	0	0	0	0	0	0	1	1	1	1	1	1	1	1	1	1	1	1	1	1	1	1
	Magenta	1	1	1	1	1	1	1	1	0	0	0	0	0	0	0	0	1	1	1	1	1	1	1	1
	Yellow	1	1	1	1	1	1	1	1	1	1	1	1	1	1	1	1	0	0	0	0	0	0	0	0
	White	1	1	1	1	1	1	1	1	1	1	1	1	1	1	1	1	1	1	1	1	1	1	1	1
Gray Scale Of Red	Red(0) / Dark	0	0	0	0	0	0	0	0	0	0	0	0	0	0	0	0	0	0	0	0	0	0	0	0
	Red(1)	0	0	0	0	0	0	0	1	0	0	0	0	0	0	0	0	0	0	0	0	0	0	0	0
	Red(2)	0	0	0	0	0	0	1	0	0	0	0	0	0	0	0	0	0	0	0	0	0	0	0	0
	⋮	⋮	⋮	⋮	⋮	⋮	⋮	⋮	⋮	⋮	⋮	⋮	⋮	⋮	⋮	⋮	⋮	⋮	⋮	⋮	⋮	⋮	⋮	⋮	⋮
	Red(253)	1	1	1	1	1	1	0	1	0	0	0	0	0	0	0	0	0	0	0	0	0	0	0	0
	Red(254)	1	1	1	1	1	1	1	0	0	0	0	0	0	0	0	0	0	0	0	0	0	0	0	0
	Red(255)	1	1	1	1	1	1	1	1	0	0	0	0	0	0	0	0	0	0	0	0	0	0	0	0
	Gray Scale Of Green	Green(0) / Dark	0	0	0	0	0	0	0	0	0	0	0	0	0	0	0	0	0	0	0	0	0	0	0
Green(1)		0	0	0	0	0	0	0	0	0	0	0	0	0	0	1	0	0	0	0	0	0	0	0	0
Green(2)		0	0	0	0	0	0	0	0	0	0	0	0	0	1	0	0	0	0	0	0	0	0	0	0
⋮		⋮	⋮	⋮	⋮	⋮	⋮	⋮	⋮	⋮	⋮	⋮	⋮	⋮	⋮	⋮	⋮	⋮	⋮	⋮	⋮	⋮	⋮	⋮	⋮
Green(253)		0	0	0	0	0	0	0	1	1	1	1	1	1	1	0	1	0	0	0	0	0	0	0	0
Green(254)		0	0	0	0	0	0	0	1	1	1	1	1	1	1	0	0	0	0	0	0	0	0	0	0
Green(255)		0	0	0	0	0	0	0	1	1	1	1	1	1	1	1	0	0	0	0	0	0	0	0	0
Gray Scale Of Blue	Blue(0) / Dark	0	0	0	0	0	0	0	0	0	0	0	0	0	0	0	0	0	0	0	0	0	0	0	0
	Blue(1)	0	0	0	0	0	0	0	0	0	0	0	0	0	0	0	0	0	0	0	0	0	0	0	1
	Blue(2)	0	0	0	0	0	0	0	0	0	0	0	0	0	0	0	0	0	0	0	0	0	0	1	0
	⋮	⋮	⋮	⋮	⋮	⋮	⋮	⋮	⋮	⋮	⋮	⋮	⋮	⋮	⋮	⋮	⋮	⋮	⋮	⋮	⋮	⋮	⋮	⋮	⋮
	Blue(253)	0	0	0	0	0	0	0	0	0	0	0	0	0	0	0	1	1	1	1	1	1	1	0	1
	Blue(254)	0	0	0	0	0	0	0	0	0	0	0	0	0	0	0	1	1	1	1	1	1	1	1	0
	Blue(255)	0	0	0	0	0	0	0	0	0	0	0	0	0	0	0	1	1	1	1	1	1	1	1	1

Note (1) 0: Low Level Voltage, 1: High Level Voltage

## 6. INTERFACE TIMING

### 6.1 INPUT SIGNAL TIMING SPECIFICATIONS

The input signal timing specifications are shown as the following table and timing diagram.

Signal	Item	Symbol	Min.	Typ.	Max.	Unit	Note
LVDS Clock	Frequency	$F_c$	60	76	96	MHz	-
	Period	$T_c$		13		ns	
	Input cycle to cycle jitter	$T_{rcj}$	TC -200		TC +200	ps	(1)
	Spread spectrum modulation range	$F_{clk_{in\_mod}}$	FC*98%		FC*102%	MHz	(2)
	Spread spectrum modulation frequency	$F_{SSM}$			200	KHz	
	High Time	$T_{ch}$	-	4/7	-	$T_c$	-
	Low Time	$T_{cl}$	-	3/7	-	$T_c$	-
LVDS Data	Setup Time	$T_{lvs}$	600	-	-	ps	(3)
	Hold Time	$T_{lvh}$	600	-	-	ps	
Vertical Active Display Term	Frame Rate	$F_r$	50	60	76	Hz	$T_v = T_{vd} + T_{vb}$
	Total	$T_v$	800	806	815	$T_h$	-
	Display	$T_{vd}$	768	768	768	$T_h$	-
Horizontal Active Display Term	Blank	$T_{vb}$	$T_v - T_{vd}$	38	$T_v - T_{vd}$	$T_h$	-
	Total	$T_h$	1500	1560	1570	$T_c$	$T_h = T_{hd} + T_{hb}$
	Display	$T_{hd}$	1366	1366	1366	$T_c$	-
	Blank	$T_{hb}$	$T_h - T_{hd}$	194	$T_h - T_{hd}$	$T_c$	-

Note: Because this module is operated by DE only mode, Hsync and Vsync input signals are ignored.

### INPUT SIGNAL TIMING DIAGRAM

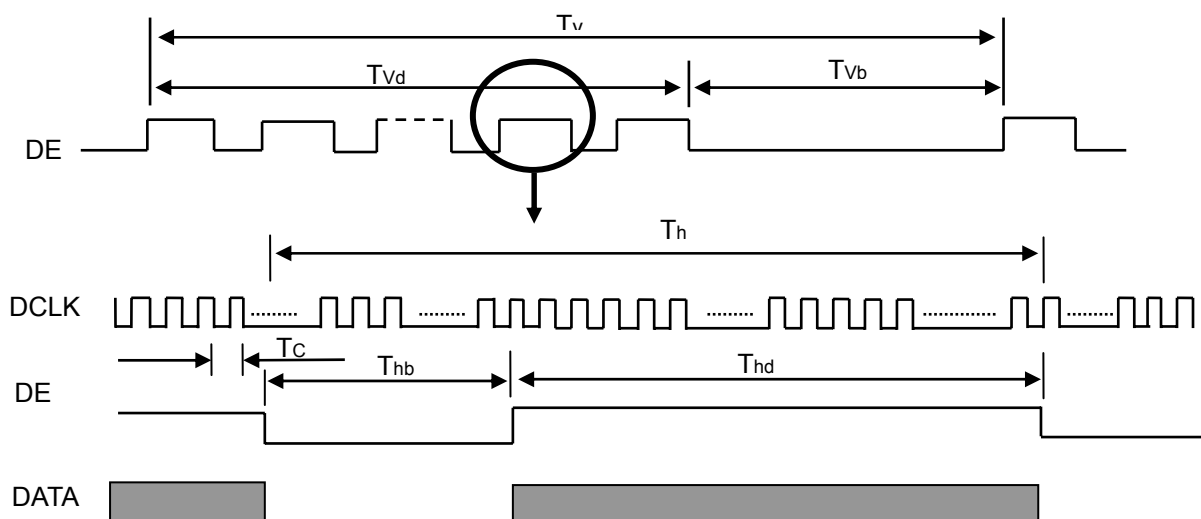

Note (1) The input clock cycle-to-cycle jitter is defined as below figures.  $Trcl = |T_1 - T_1|$

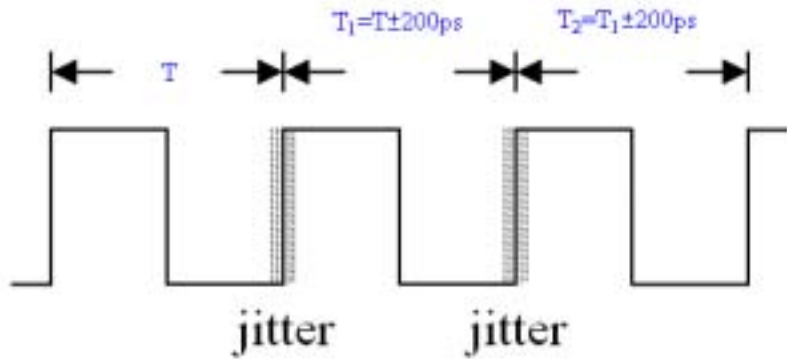

Note (2) The SSCG (Spread spectrum clock generator) is defined as below figures

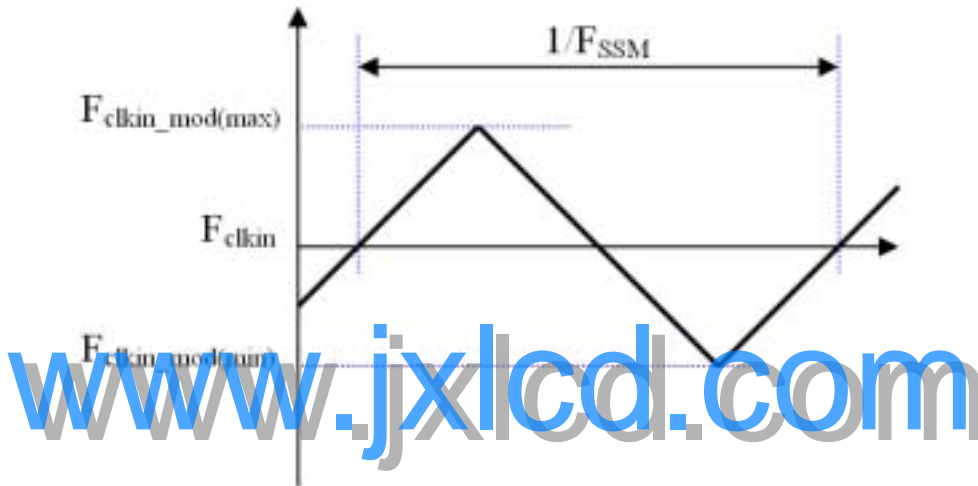

Note (3) The LVDS timing diagram and setup/hold time is defined and showing as the following figures

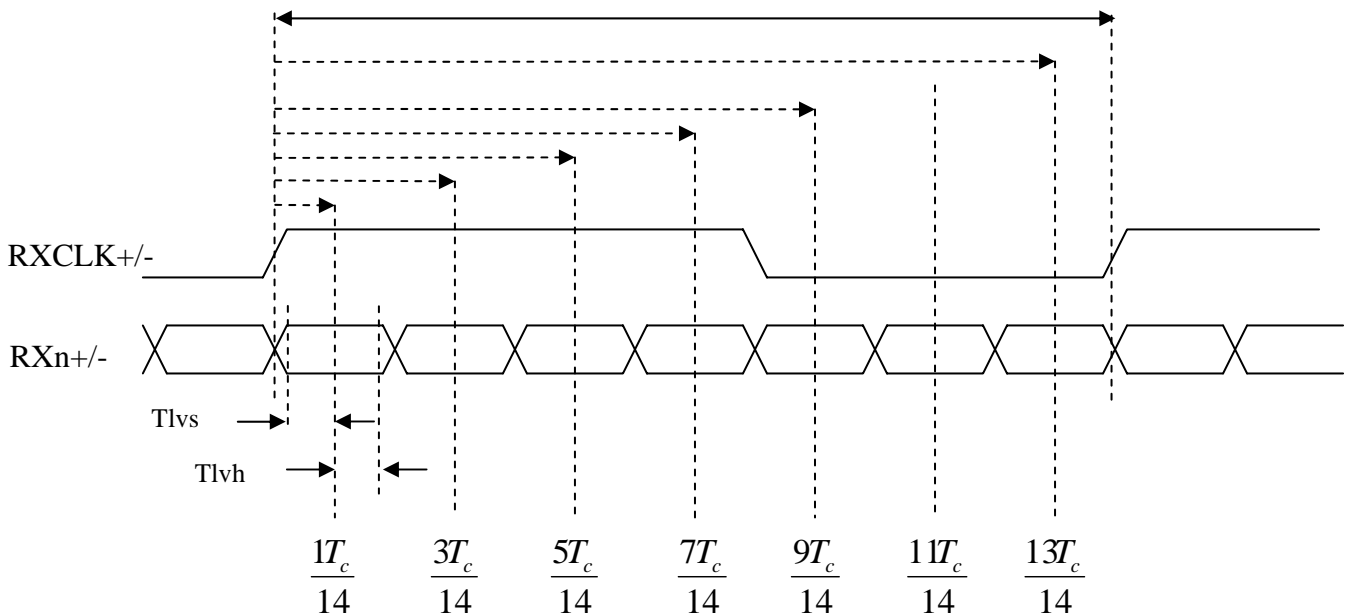

## 6.2 POWER ON/OFF SEQUENCE

To prevent a latch-up or DC operation of LCD module, the power on/off sequence should be as the diagram below.

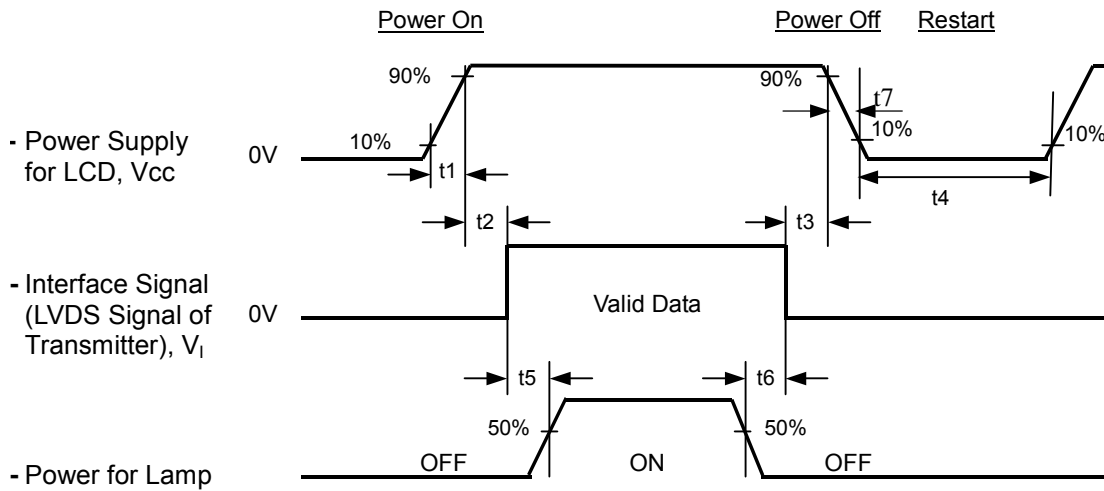

### Timing Specifications:

$$0.5 < t_1 \leq 10 \text{ msec}$$

$$0 < t_2 \leq 50 \text{ msec}$$

$$0 < t_3 \leq 50 \text{ msec}$$

$$t_4 \geq 500 \text{ msec}$$

$$t_5 \geq 450 \text{ msec}$$

$$t_6 \geq 90 \text{ msec}$$

$$5 \leq t_7 \leq 100 \text{ msec}$$

### Note.

- (1) The supply voltage of the external system for the module input should be the same as the definition of Vcc.
- (2) When the backlight turns on before the LCD operation of the LCD turns off, the display may momentarily become abnormal screen.
- (3) In case of Vcc = off level, please keep the level of input signals on the low or keep a high impedance.
- (4) t4 should be measured after the module has been fully discharged between power of and on period.
- (5) Interface signal shall not be kept at high impedance when the power is on.
- (6) CMO won't take any responsibility for the products which are damaged by the customers not following the Power Sequence.
- (7) There might be slight electronic noise when LCD is turned off (even backlight unit is also off). To avoid this symptom, we suggest "Vcc falling timing" to follow "t7 spec".



## 7. OPTICAL CHARACTERISTICS

### 7.1 TEST CONDITIONS

Item	Symbol	Value	Unit
Ambient Temperature	Ta	25±2	°C
Ambient Humidity	Ha	50±10	%RH
Supply Voltage	V <sub>CC</sub>	5.0	V
Input Signal	According to typical value in "3. ELECTRICAL CHARACTERISTICS"		
LED Light Bar Input Current (per pin)	I <sub>pin</sub>	20±0.6	mA
PWM Duty Ratio	D	100	%
LED Light Bar Test Converter	CMO 27-D041745		

### 7.2 OPTICAL SPECIFICATIONS

The relative measurement methods of optical characteristics are shown in 7.2. The following items should be measured under the test conditions described in 7.1 and stable environment shown in Note (5).

Item	Symbol	Condition	Min.	Typ.	Max.	Unit	Note	
Color Chromaticity (CIE 1931)	Red	R <sub>x</sub>	θ <sub>x</sub> =0°, θ <sub>y</sub> =0° CS-2000	0.6329	Typ - 0.03	Typ + 0.03	-	(1), (5)
		R <sub>y</sub>		0.3413				
	Green	G <sub>x</sub>		0.3192				
		G <sub>y</sub>		0.5979				
	Blue	B <sub>x</sub>		0.1572				
		B <sub>y</sub>		0.0766				
	White	W <sub>x</sub>		0.3130				
		W <sub>y</sub>		0.3290				
Center Luminance of White (Center of Screen)	L <sub>c</sub>		200	250	-	cd/m <sup>2</sup>	(4), (5)	
Contrast Ratio	CR		350	500	-	-	(2), (5)	
Response Time	T <sub>R</sub>	θ <sub>x</sub> =0°, θ <sub>y</sub> =0°	-	2	4	ms	(3), (7)	
	T <sub>F</sub>		-	6	12			
	T <sub>GIG AVE</sub>		-	-	-			
White Variation	δW	θ <sub>x</sub> =0°, θ <sub>y</sub> =0°	---	---	1.33	-	(5), (6)	
Viewing Angle	Horizontal	θ <sub>x+</sub> + θ <sub>x-</sub>	CR 5	90	100	-	Deg.	(1), (5)
	Vertical	θ <sub>y+</sub> +θ <sub>y-</sub>		70	80	-		
Viewing Angle	Horizontal	θ <sub>x+</sub> + θ <sub>x-</sub>	CR 10	80	90	-	Deg.	(1), (5)
	Vertical	θ <sub>y+</sub> +θ <sub>y-</sub>		55	65	-		

Note (1) Definition of Viewing Angle ( $\theta_x$ ,  $\theta_y$ ):

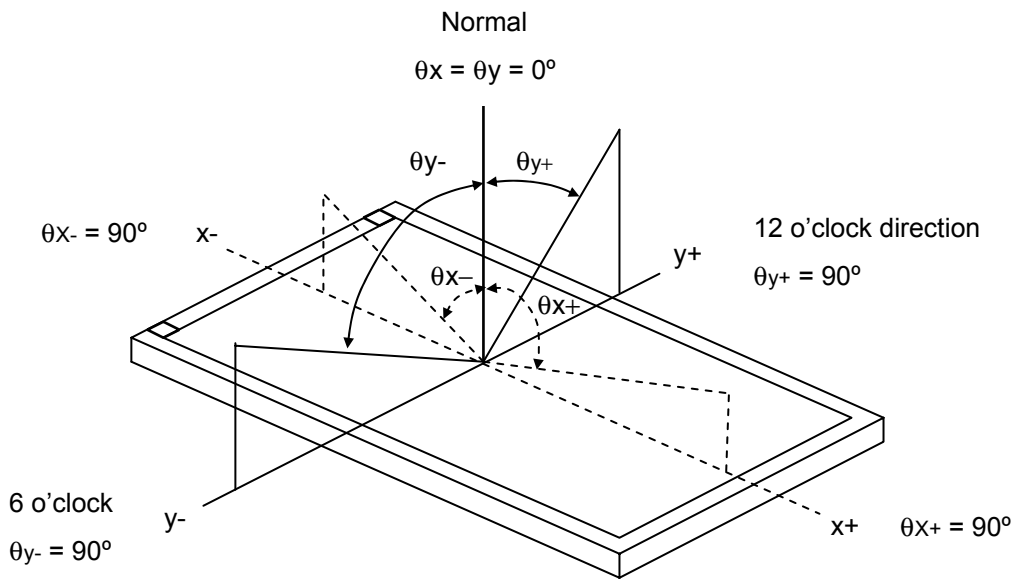

Note (2) Definition of Contrast Ratio (CR):

The contrast ratio can be calculated by the following expression.

$$\text{Contrast Ratio (CR)} = L_{255} / L_0$$

L255: Luminance of gray level 255

L 0: Luminance of gray level 0

$$CR = CR (1)$$

CR (X) is corresponding to the Contrast Ratio of the point X at Figure in Note (6).

Note (3) Definition of Response Time ( $T_R$ ,  $T_F$ ):

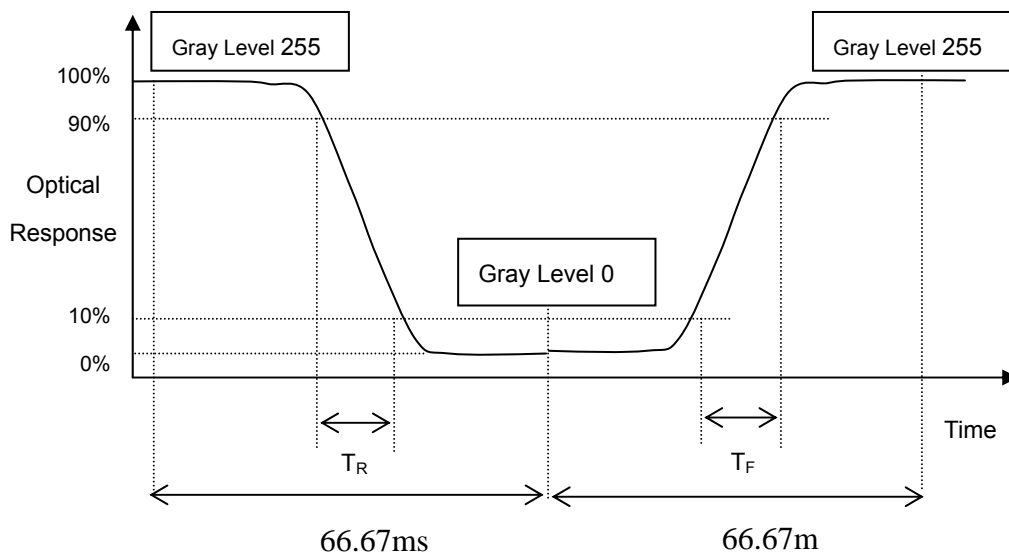

Note (4) Definition of Luminance of White ( $L_C$ ):

Measure the luminance of gray level 255 at center point

$$L_C = L(1)$$

$L(x)$  is corresponding to the luminance of the point X at Figure in Note (6).

Note (5) Measurement Setup:

The LCD module should be stabilized at given temperature for 40 minutes to avoid abrupt temperature change during measuring. In order to stabilize the luminance, the measurement should be executed after lighting Backlight for 40 minutes in a windless room.

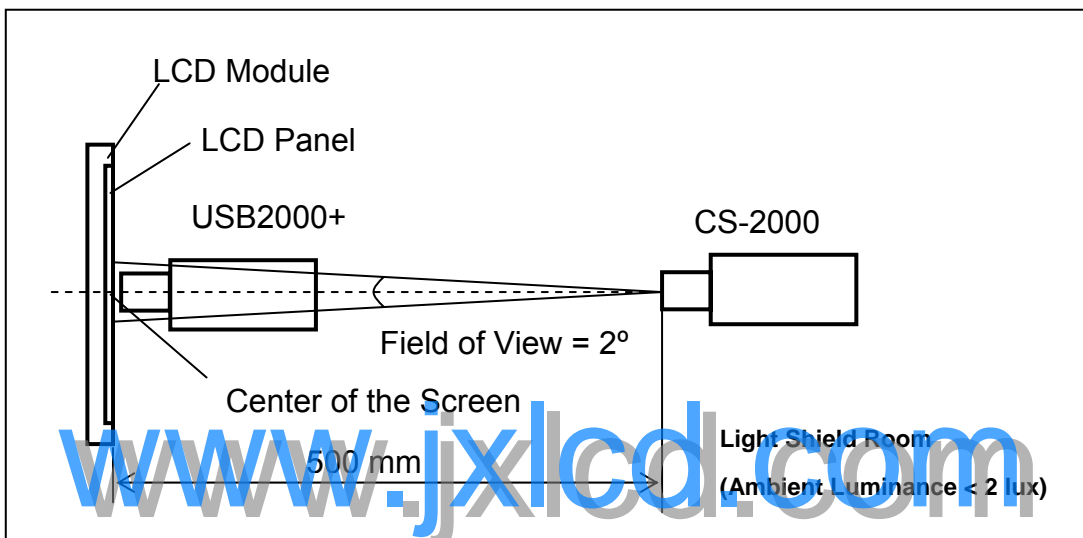

Note (6) Definition of White Variation ( $\delta W$ ):

Measure the luminance of gray level 255 at 9 points

$$\delta W = \text{Maximum} [L(1), L(2) \dots L(4), L(9)] / \text{Minimum} [L(1), L(2) \dots L(4), L(9)]$$

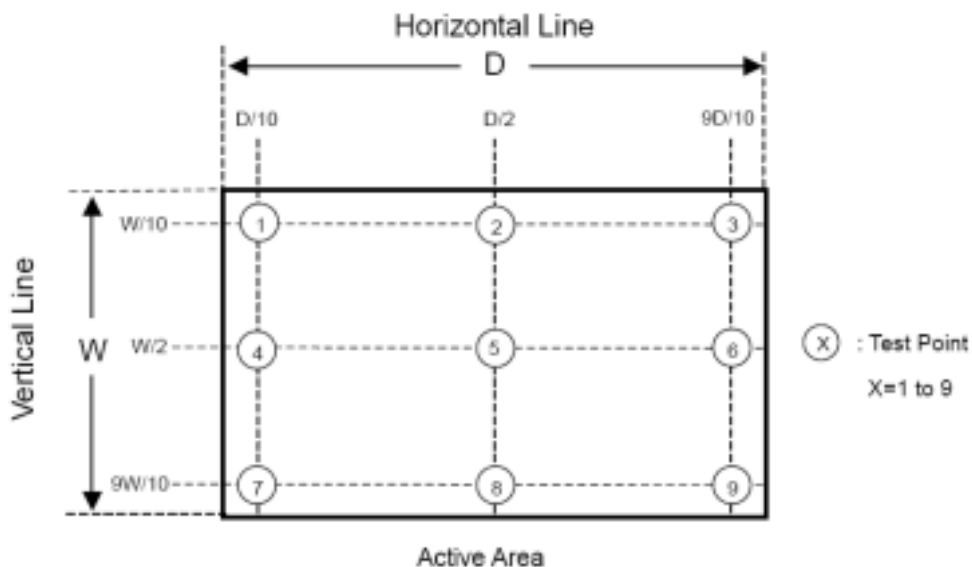

## 8. PACKAGING

### 8.1 PACKING SPECIFICATIONS

- (1) 12 LCD modules / 1 Box
- (2) Box dimensions: 490(L) X 325(W) X 320(H) mm
- (3) Weight: approximately 15.7Kg (12 modules per box)

### 8.2 PACKING METHOD

- (1) Carton Packing should have no failure in the following reliability test items.

Test Item	Test Conditions	Note
Vibration	ISTA STANDARD Random, Frequency Range: 1 – 200 Hz Top & Bottom: 30 minutes (+Z), 10 min (-Z), Right & Left: 10 minutes (X) Back & Forth 10 minutes (Y)	Non Operation
Dropping Test	1 Corner, 3 Edge, 6 Face, ISTA STANDARD	Non Operation

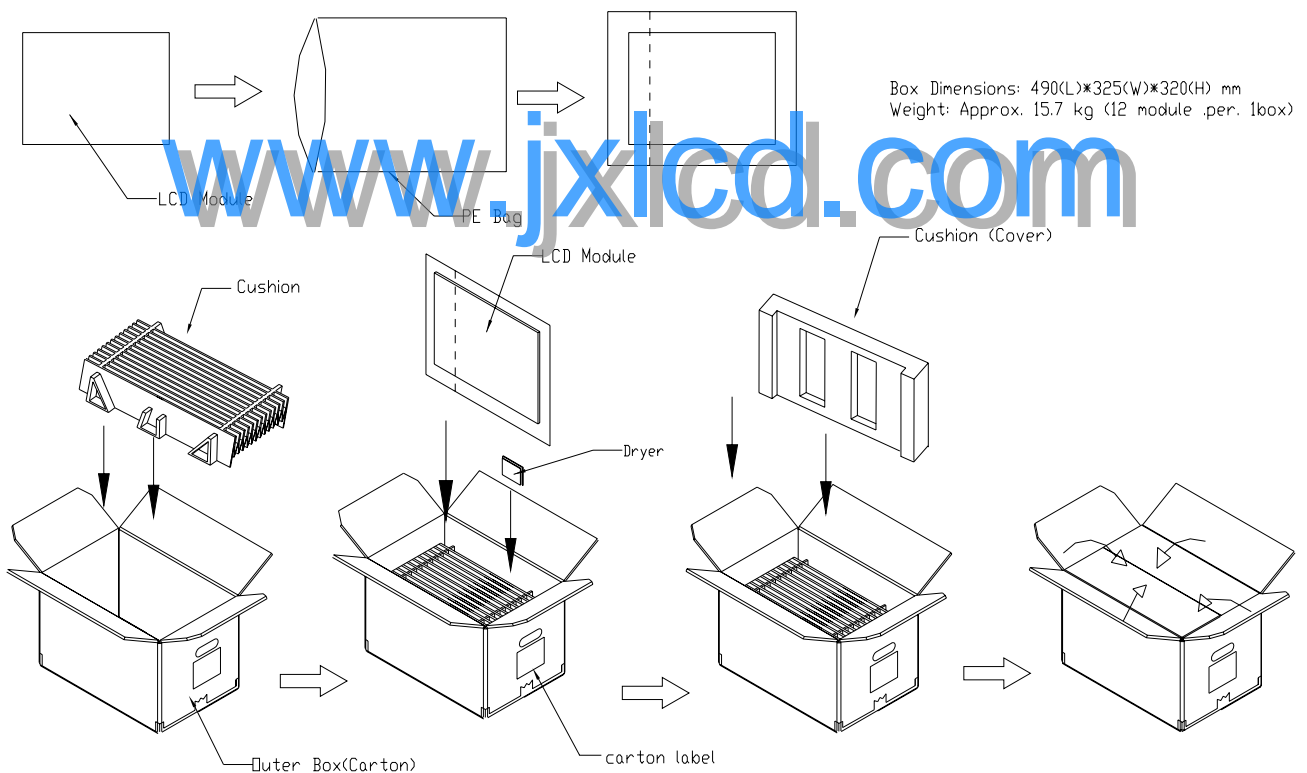

**Figure. 8-1 Packing method**

For ocean shipping

Sea / Land Transportation (40ft Container)

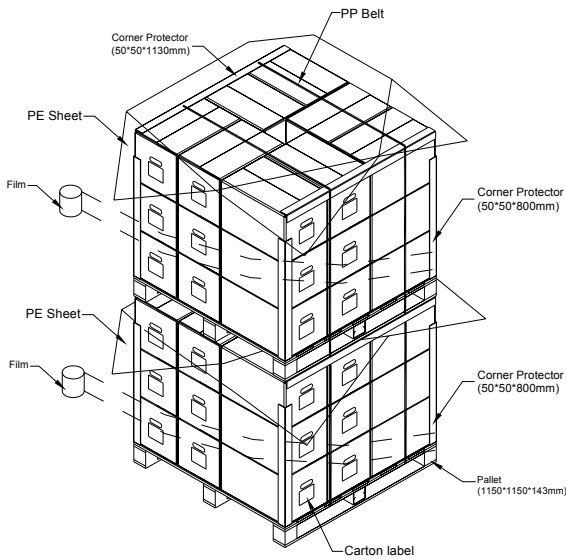

Figure. 8-2 Packing method

[www.jxlcd.com](http://www.jxlcd.com)

For air transport

Air transportation

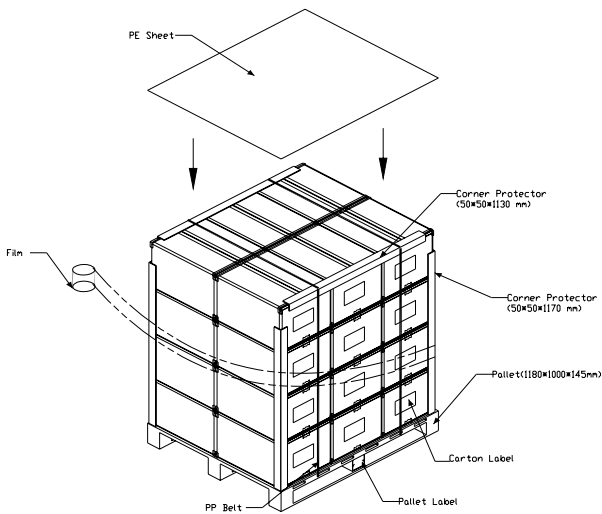

Figure. 8-3 Packing method

## 9. DEFINITION OF LABELS

### 9.1 CMO MODULE LABEL

The barcode nameplate is pasted on each module as illustration, and its definitions are as following explanation.



- (a) Model Name: M156B3-LA1
- (b) Revision: Rev. XX, for example: A0, A1... B1, B2... or C1, C2...etc.
- (c) CMO barcode definition:

Serial ID: XX-XX-X-XX-YMD-L-NNNN

Code	Meaning	Description
XX	CMO internal use	-
XX	Revision	Cover all the change
X	CMO internal use	-
YMD	Year, month, day	Year: 0~9, 2001=1, 2002=2, 2003=3...2010=0, 2011=1, 2012=2... Month: 1~12=1, 2, 3, ~, 9, A, B, C Day: 1~31=1, 2, 3, ~, 9, A, B, C, ~, W, X, Y, exclude I, O, and U.
L	Product line #	Line 1=1, Line 2=2, Line 3=3, ...
NNNN	Serial number	Manufacturing sequence of product

- (d) Customer's barcode definition:

Serial ID: CM-15E31-X-X-X-XX-L-XX-L-YMD-NNNN

Code	Meaning	Description
CM	Supplier code	CMO=CM
F63A1	Model number	M156B3-LA1=F63A1
X	Revision code	Non ZBD: 1,2,~,8,9 / ZBD: A~Z
X	Source driver IC code	Century=1, CLL=2, Demos=3, Epson=4, Fujitsu=5, Himax=6, Hitachi=7, Hynix=8, LDI=9, Matsushita=A, NEC=B, Novatec=C, OKI=D, Philips=E, Renasas=F, Samsung=G, Sanyo=H, Sharp=I, TI=J, Topro=K, Toshiba=L, Windbond=M
X	Gate driver IC code	OKI=D, Philips=E, Renasas=F, Samsung=G, Sanyo=H, Sharp=I, TI=J, Topro=K, Toshiba=L, Windbond=M
XX	Cell location	Tainan, Taiwan=TN
L	Cell line #	1,2,~,9,A,B,~,Y,Z
XX	Module location	Tainan, Taiwan=TN ; Ningbo China=NP
L	Module line #	1,2,~,9,A,B,~,Y,Z
YMD	Year, month, day	Year: 0~9, 2001=1, 2002=2, 2003=3...2010=0, 2011=1, 2012=2... Month: 1~12=1, 2, 3, ~, 9, A, B, C Day: 1~31=1, 2, 3, ~, 9, A, B, C, ~, T, U, V
NNNN	Serial number	Manufacturing sequence of product

- (e) FAB ID(UL Factory ID):

Region	Factory ID
TWCMO	GEMN
NBCMO	LEOO
NBCME	CANO
NHCMO	CAPG

## 10. Reliability Test

Environment test conditions are listed as following table.

Items	Required Condition	Note
Temperature Humidity Bias (THB)	Ta= 50 , 80%RH, 240hours	
High Temperature Operation (HTO)	Ta= 50 , 50%RH , 240hours	
Low Temperature Operation (LTO)	Ta= 0 , 240hours	
High Temperature Storage (HTS)	Ta= 60 , 240hours	
Low Temperature Storage (LTS)	Ta= -20 , 240hours	
Vibration Test (Non-operation)	Acceleration: 1.5 Grms Wave: Half-sine Frequency: 10 - 300 Hz Sweep: 30 Minutes each Axis (X, Y, Z)	
Shock Test (Non-operation)	Acceleration: 50 G Wave: Half-sine Active Time: 11 ms Direction : ± X, ± Y, ± Z.(one time for each Axis)	
Thermal Shock Test (TST)	-20 /30min , 60 / 30min , 100 cycles	
On/Off Test	25 ,On/10sec , Off /10sec , 30,000 cycles	
ESD (Electro Static Discharge)	Contact Discharge: ± 8KV, 150pF(330Ω)	
	Air Discharge: ± 15KV, 150pF(330Ω)	
Altitude Test	Operation:10,000 ft / 24hours	
	Non-Operation:30,000 ft / 24hours	

[www.jxlcd.com](http://www.jxlcd.com)

## 11. PRECAUTIONS

### 11.1 ASSEMBLY AND HANDLING PRECAUTIONS

- (1) Do not apply rough force such as bending or twisting to the module during assembly.
- (2) To assemble or install module into user's system can be only in clean working areas. The dust and oil may cause electrical short or worsen the polarizer.
- (3) It's not permitted to have pressure or impulse on the module because the LCD panel and Backlight will be damaged.
- (4) Always follow the correct power sequence when LCD module is connecting and operating. This can prevent damage to the CMOS LSI chips during latch-up.
- (5) Do not pull the I/F connector in or out while the module is operating.
- (6) Do not disassemble the module.
- (7) Use a soft dry cloth without chemicals for cleaning, because the surface of polarizer is very soft and easily scratched.
- (8) It is dangerous that moisture come into or contacted the LCD module, because moisture may damage LCD module when it is operating.
- (9) High temperature or humidity may reduce the performance of module. Please store LCD module within the specified storage conditions.
- (10) When ambient temperature is lower than 10°C may reduce the display quality. For example, the response time will become slowly.

### 11.2 SAFETY PRECAUTIONS

- (1) If the liquid crystal material leaks from the panel, it should be kept away from the eyes or mouth. In case of contact with hands, skin or clothes, it has to be washed away thoroughly with soap.
- (2) After the module's end of life, it is not harmful in case of normal operation and storage.

### 11.3 SAFETY STANDARDS

The LCD module should be certified with safety regulations as follows:

- (1) UL60950-1 or updated standard.
- (2) IEC60950-1 or updated standard.

### 11.4. Storage

- (1) Do not leave the module in high temperature, and high humidity for a long time.  
It is highly recommended to store the module with temperature from 0 to 35  
And relative humidity of less than 70%
- (2) Do not store the TFT – LCD module in direct sunlight
- (3) The module should be stored in dark place. It is prohibited to apply sunlight or fluorescent light in storing

### 11.5. Operation condition guide

- (1) The LCD product should be operated under normal condition.  
Normal condition is defined as below :



Temperature :  $20\pm 15$

Humidity:  $65\pm 20\%$

Display pattern : continually changing pattern(Not stationary)

- (2) If the product will be used in extreme conditions such as high temperature , high humidity , high altitude , display pattern or operation time etc...It is strongly recommended to contact CMO for application engineering advice . Otherwise , Its reliability and function may not be guaranteed.

#### 11.6 OTHER

When fixed patterns are displayed for a long time, remnant image is likely to occur.

## 12. MECHANICAL CHARACTERISTICS

[Refer to the next 2 pages]

[www.jxlcd.com](http://www.jxlcd.com)

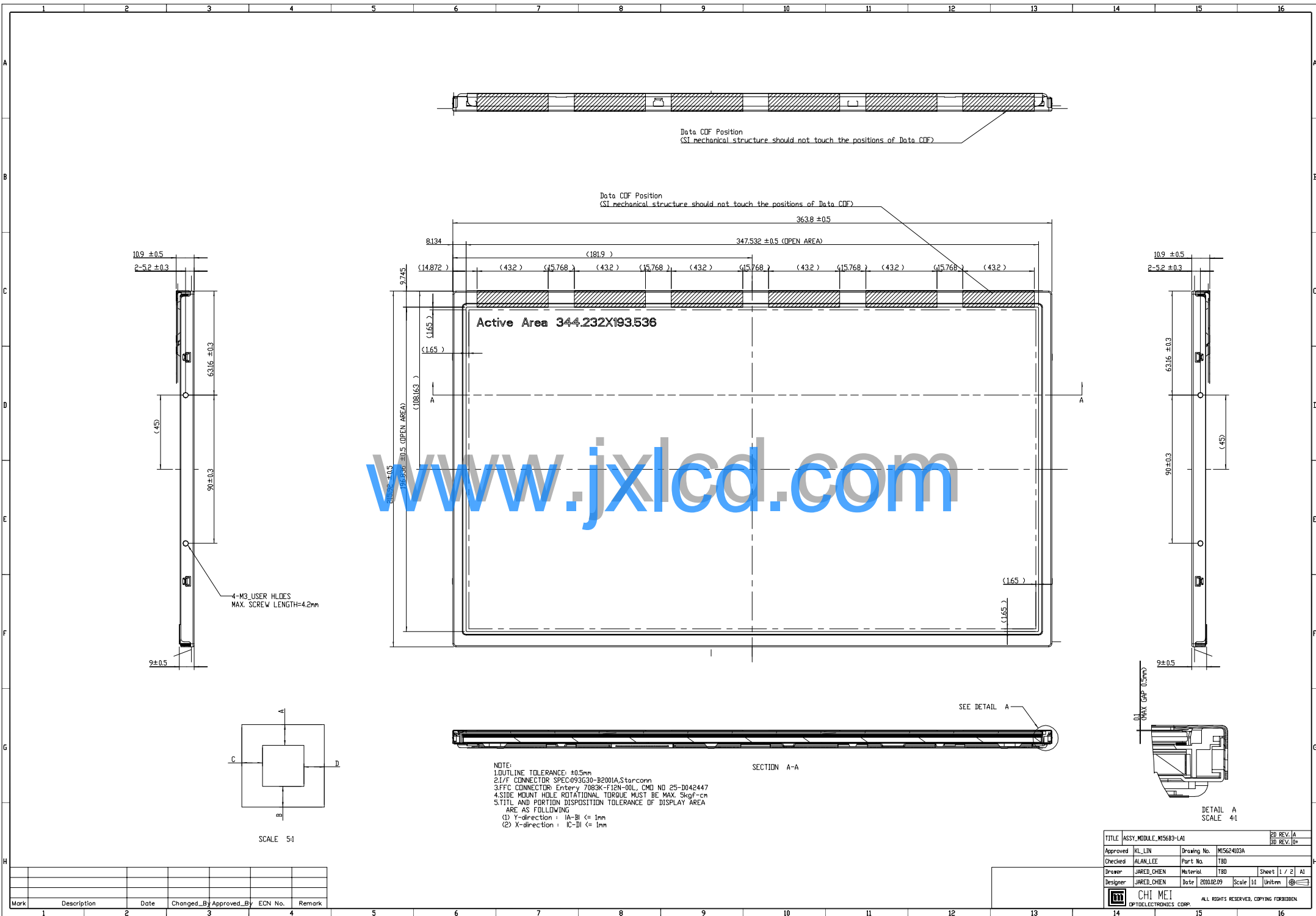

Data CDF Position  
(SI mechanical structure should not touch the positions of Data CDF)

Data CDF Position  
(SI mechanical structure should not touch the positions of Data CDF)

Active Area 344.232X193.536

www.jxlcd.com

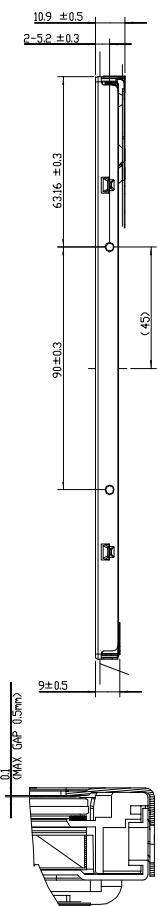
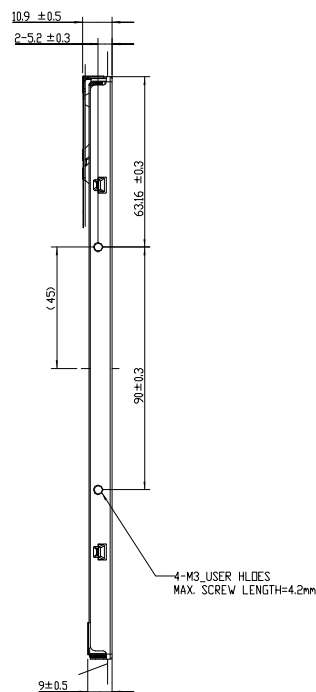

NOTE:  
 1. OUTLINE TOLERANCE: ±0.5mm  
 2. I/F CONNECTOR SPEC: 093G30-B2001A, Starconn  
 3. I/F CONNECTOR: Entery 7083K-F12N-00L, CMD NO 25-2042447  
 4. SIDE MOUNT HOLE ROTATIONAL TORQUE MUST BE MAX. 5kgf-cm  
 5. TITLE AND PORTION DISPOSITION OF DISPLAY AREA  
 ARE AS FOLLOWING  
 (1) Y-direction : IA-BI <= 1mm  
 (2) X-direction : IC-DI <= 1mm

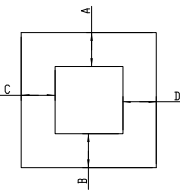

SCALE 5:1

TITLE ASSY_MODULE_M15693-LA1		ED REV. IA
Approved KL_LIN		Drawing No. M15624103A
Checked ALAN_LIE	Part No. TBD	BD REV. 0*
Drawer JARED_CHEN	Material TBD	Sheet 1 / 2   A1
Designer JARED_CHEN	Date 20100209	Scale 1:1
		ALL RIGHTS RESERVED, COPYING FORBIDDEN

Mark	Description	Date	Changed_By	Approved_By	ECN No.	Remark
1						
2						
3						
4						

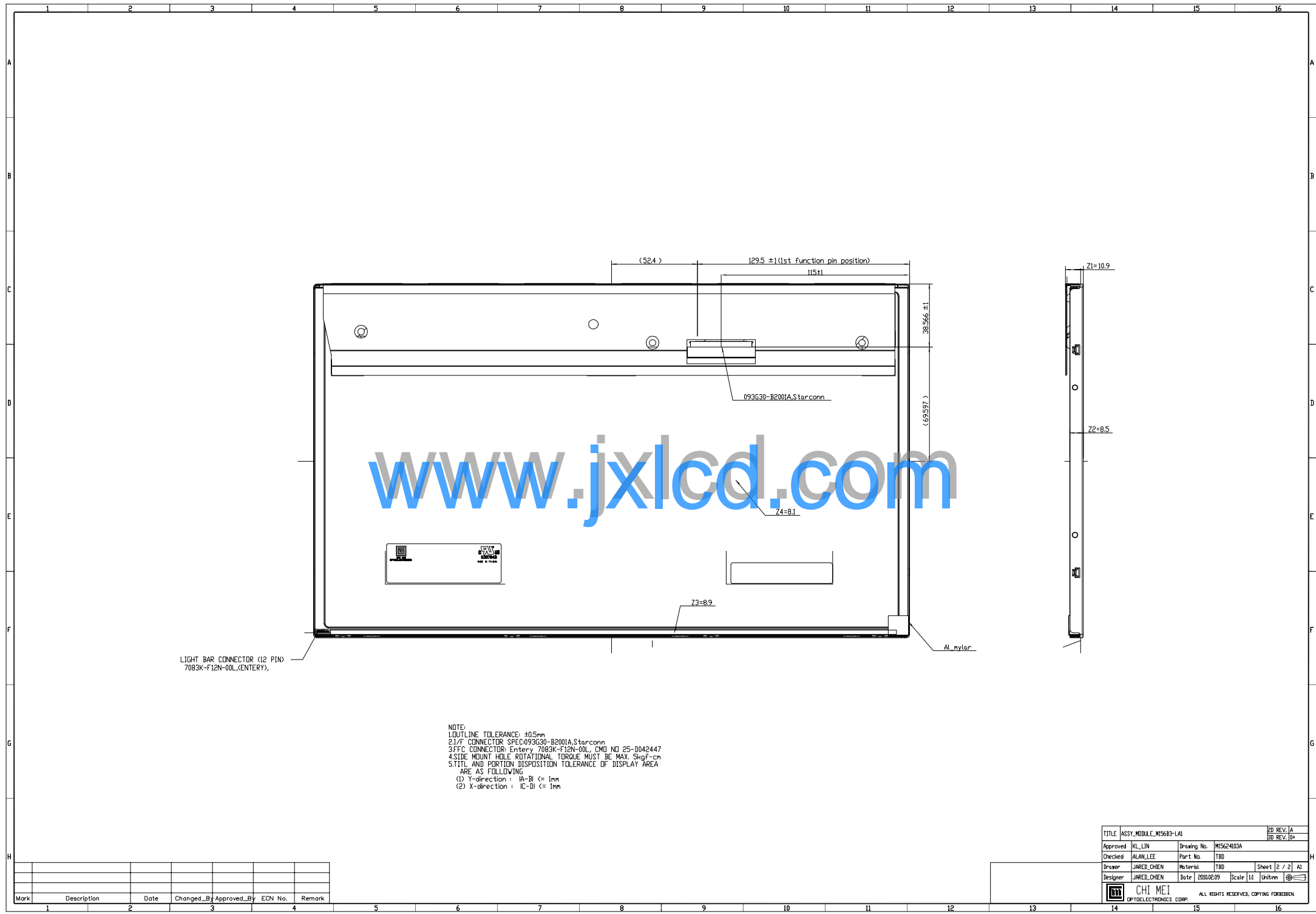

LIGHT BAR CONNECTOR (12 PIN)  
7083K-F12N-00L, CENTER)

NOTE:  
 1. OUTLINE TOLERANCE: 40.5mm  
 2. I/F CONNECTOR: SPEC:093G30-B2001A, Starconn  
 3. FFC CONNECTOR: Entery 7083K-F12N-00L, CMD NO 25-0042447  
 4. SIDE MOUNT HOLE ROTATIONAL TORQUE MUST BE MAX. 5kgf-cm  
 5. TITLE AND PORTION DISPOSITION TOLERANCE OF DISPLAY AREA ARE AS FOLLOWING  
 (1) Y-direction : IA-BI <= 1mm  
 (2) X-direction : IC-DI <= 1mm

Mark	Description	Date	Changed_By	Approved_By	ECN No.	Remark
1						
2						
3						
4						

TITLE ASSY_MODULE_M15693-LA1			ED REV. IA
Approved	KL_LIN	Drawing No.	M1562403A
Checked	ALAN_LIE	Part No.	TBD
Designer	JARED_CHEN	Material	TBD
Date	20100209	Scale	1:1
Unit	mm	Sheet	2 / 2
CHI MEI OPTOELECTRONICS CORP.			ALL RIGHTS RESERVED, COPYING FORBIDDEN