

**InfoVision Optoelectronics (Kunshan) Co.,LTD.**

Document Title	M156NWR1 R0 Product Information			Page No.	1/32
Document No.		Issue date	2009/10/08	Revision	V02

Product Information

To:

Product Name: M156NWR1 R0

Document Issue Date: 2009/10/08

- Note: 1. Please contact liforVision Company. before designing your product based on this product.
2. The information contained herein is presented merely to indicate the characteristics and performance of our products. No responsibility is assumed by IVO for any intellectual property claims or other problems that may result from application based on the module described herein.

FQ-7-30-0-009-02C

NO.1 Long Teng Road, KunShan City, JiangSu, China
InfoVision Optoelectronics (Kunshan) Co., LTD

Tel:0512-57278888
Fax:0512-57278900



InfoVision Optoelectronics (Kunshan) Co.,LTD.

Document Title	M156NWR1 R0 Product Information			Page No.	2/32
Document No.		Issue date	2009/10/08	Revision	V02

Revision	Date	Page	Old Description	New Description	Remark
00	2008/08/02	All	-	First issued.	
01	2008/10/18	8	-	Add RGB color Chromaticity	
01	2008/10/18	11	-	Add CCFL voltage	
01	2008/10/18	20	-	Add H Total Time, V total Time	
01	2008/10/18	22	-	Add IDd\PDD\Irush\VDD	
01	2008/10/18	24,26	CCFL cable length 100±5mm	Modify Front side outline drawing, CCFL cable length 100±5mm to 120±5mm	
01	2008/10/18		-	Modify general precaution	
01	2008/10/18	31-32	-	Add EDID	
02	2009/07/20	31-32	-	Modify EDID address 54,64,127	



InfoVision Optoelectronics (Kunshan) Co.,LTD.

Document Title	M156NWR1 R0 Product Information			Page No.	3/32
Document No.		Issue date	2009/10/08	Revision	V02

Contents

1.0	General Description	4
2.0	Absolute Maximum Ratings.....	6
3.0	Pixel Format Image.....	7
4.0	Optical Characteristics	8
5.0	Backlight Characteristics	11
6.0	Electrical Characteristics	13
7.0	Interface Timings.....	18
8.0	Power Consumption	20
9.0	Power ON/OFF Sequence.....	21
10.0	Mechanical Characteristics.....	22
11.0	Package Specification	25
12.0	Lot Mark	26
13.0	General Precaution	27
14.0	EDID Data Structure	29



InfoVision Optoelectronics (Kunshan) Co.,LTD.

Document Title	M156NWR1 R0 Product Information			Page No.	4/32
Document No.		Issue date	2009/10/08	Revision	V02

1.0 General Description

1.1 Introduction

The M156NWR1 is a color active matrix thin film transistor (TFT) liquid crystal display (LCD) that uses amorphous silicon TFT as a switching device. It is composed of a TFT LCD panel, a timing controller, voltage reference, common voltage driver, DC-DC converter, column driver, and row driver circuit. This TFT LCD has a 15.6-inch diagonally measured active display area with WXGA resolution (1,366 vertical by 768 horizontal pixel array).

1.2 Features

- 15.6" WXGA TFT LCD Panel
- 1 CCFL Backlight System
- Supported WXGA (V:1,366 lines, H:768 pixels) resolution
- Compatible with RoHS Standard

1.3 Product Summary

Items	Specifications	Unit
Screen Diagonal	15.6 inch Diagonal	Inch
Active Area	344.232(H) x 193.536(V)	mm
Pixels H x V	1,366 (x3) x 768	
Pixel Pitch	0.252*0.252	mm
Pixel Arrangement	R.G.B. Vertical Stripe	
Display Mode	Normally White	
White Luminance	220 typical	cd/ m ² (CCFL current 6.0mA)
Contrast Ratio	500 : 1 typical	
Response Time	8 typical	msec
Input Voltage	+3.3 typical	V
Power Consumption	7W	Watt
Weight	550 max	g
Outline Dimension	359.3(type.)*209.5(type.)*5.9(type.)	mm
Electrical Interface (Logic)	LVDS	
Support Color	262 K	
Lamp Life Time	15,000(Ta=25+/-3degC and ICCFL=6.0mA, brightness becomes lower than 50% of initial value)	Hours
Luminance Uniformity	1.25 max (@5points)	
Optimum Viewing Direction	6 o'clock	
Surface Treatment	Glare type+ hardcoating	



InfoVision Optoelectronics (Kunshan) Co.,LTD.

Document Title	M156NWR1 R0 Product Information			Page No.	5/32
Document No.		Issue date	2009/10/08	Revision	V02

1.4 Functional Block Diagram

Figure 1 shows the functional block diagram of the LCD module.

Figure 1 Block Diagram

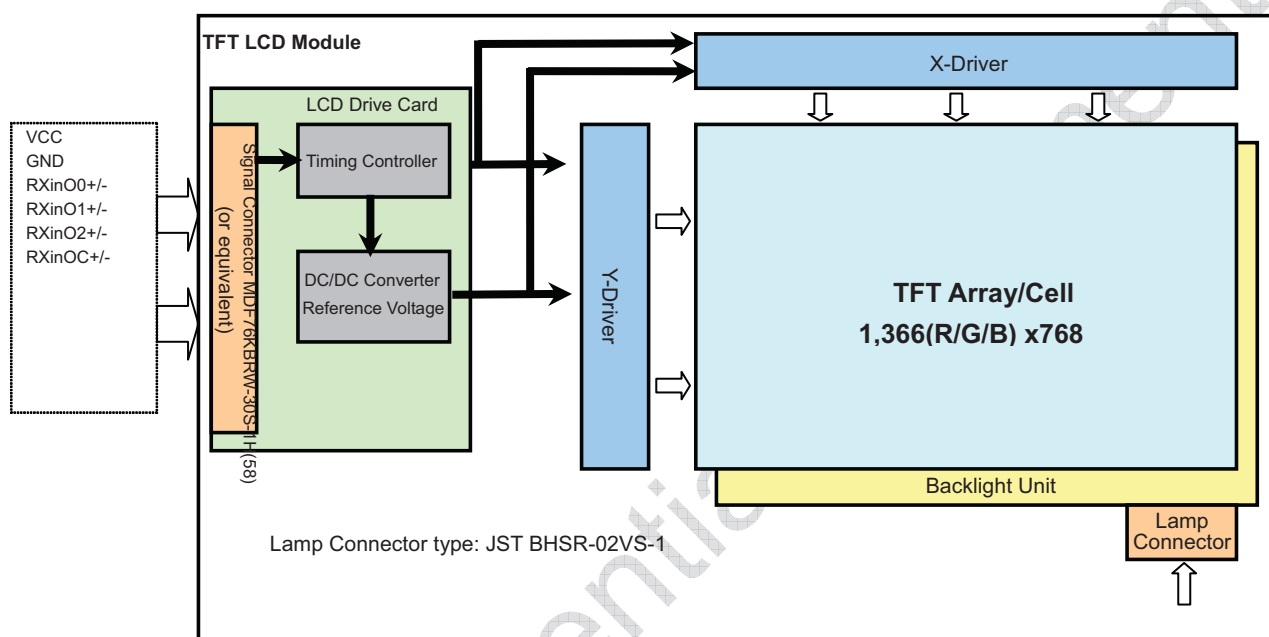



InfoVision Optoelectronics (Kunshan) Co.,LTD.

Document Title	M156NWR1 R0 Product Information			Page No.	6/32
Document No.		Issue date	2009/10/08	Revision	V02

2.0 Absolute Maximum Ratings

Table 1 Absolute Ratings of Environment

Item	Symbol	Min	Max	Unit	Conditions
Supply Voltage	VDD	-0.5	3.6	V	
Input Signal	--	-0.5	2.6	V	LVDS signals
Operating Temperature	TOP	0	50	deg. C	(Note)
Operating Humidity	HOP	--	80	%RH	(Note)
Storage Temperature	TST	-20	60	deg. C	(Note)
Storage Humidity	HST	--	90	%RH	at Ta < 40°C, No condensation.
Vibration	--	--	1.5G 10-500-10Hz	G Hz	Random,30min for X, Y, Z axis
Shock	--	--	220G 2ms	G ms	Half sign wave ,one cycle for each x,y,z axis
CCFL Current	ICCFL	--	6.5	mArms	

Note (1) Storage /Operating temperature. Maximum Wet-Bulb should be 39 degree C. No condensation.

(2) When you apply the LCD module for OA system. Please make sure to keep the temperature of LCD module is less than 60°C.

Figure 1 shows the absolute ratings of environment of the LCD module.

Figure 2 Absolute Ratings of Environment Diagram

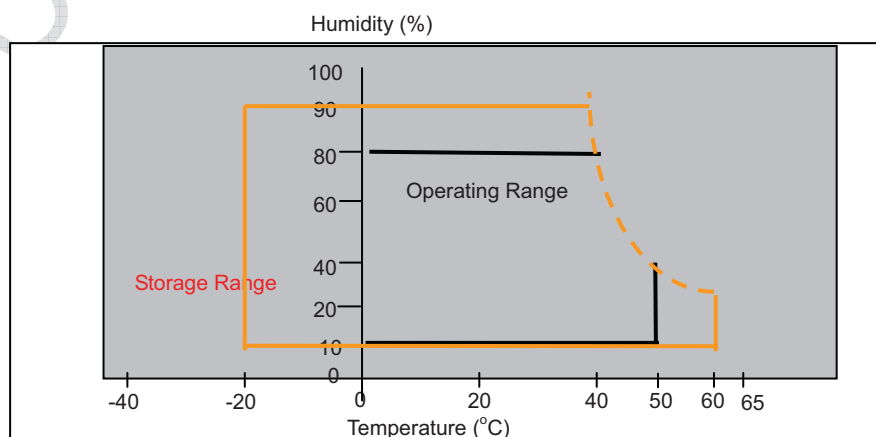



InfoVision Optoelectronics (Kunshan) Co.,LTD.

Document Title	M156NWR1 R0 Product Information			Page No.	7/32
Document No.		Issue date	2009/10/08	Revision	V02

3.0 Pixel Format Image

shows the relationship of the input signals and LCD pixel format image.

Figure 3 Pixel Format

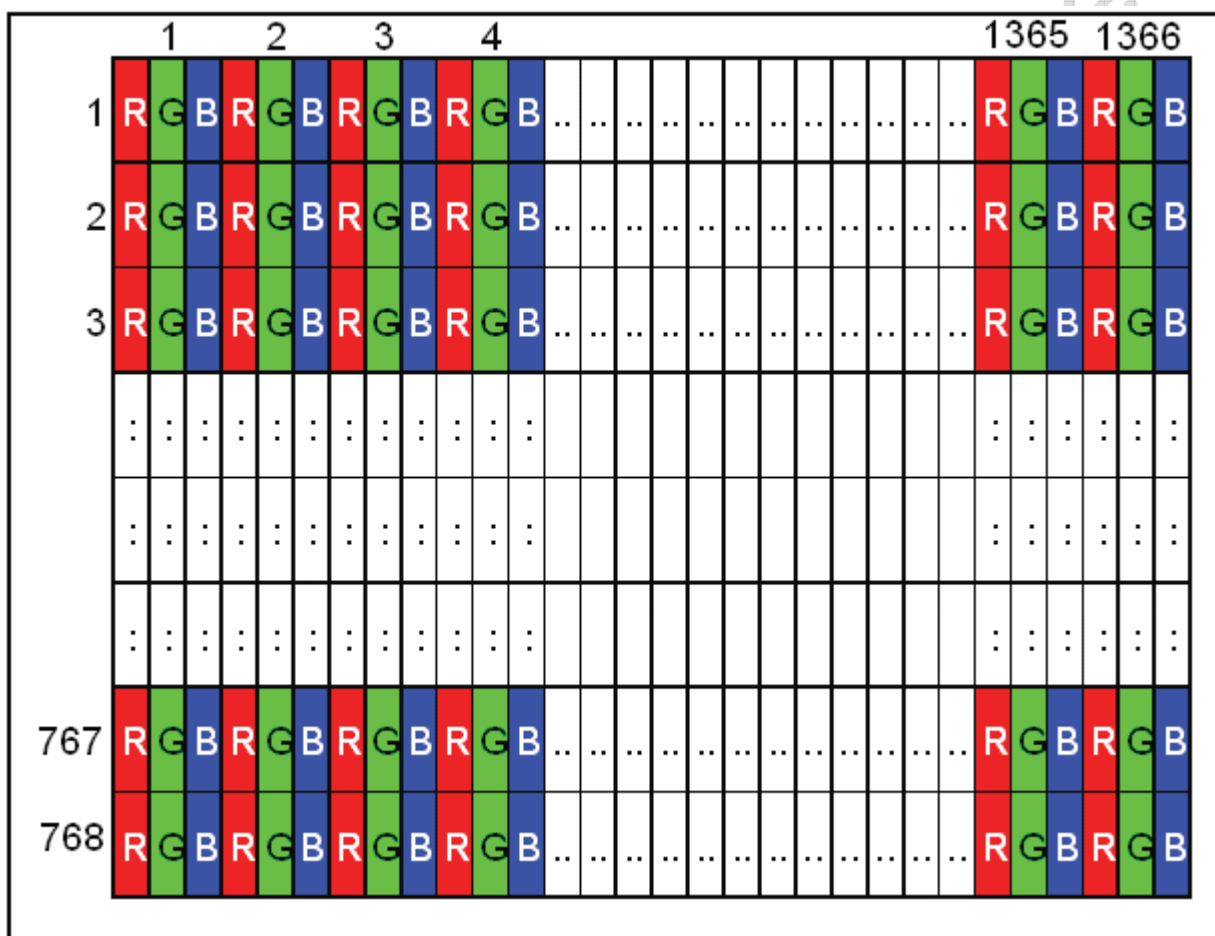



InfoVision Optoelectronics (Kunshan) Co.,LTD.

Document Title	M156NWR1 R0 Product Information			Page No.	8/32
Document No.		Issue date	2009/10/08	Revision	V02

4.0 Optical Characteristics

The optical characteristics are measured under stable conditions as following notes

Table 4 Optical characteristics

Item	Conditions		Specification			
			Min	Typ.	Max	Note
Viewing Angle [degrees] K=Contrast Ratio>10	Horizontal	Left	40	45	--	A, B
		Right	40	45	--	
	Vertical	Up	10	15	--	
		Down	30	35	--	
Contrast ratio	Center		400	500	--	A, C
Response Time [ms]	Rising + Falling		--	8	15	A, D
Color Chromaticity (CIE1931)	Red	x	Typ. -0.03	0.646	Typ. +0.03	A,
	Red	y		0.339		A,
	Green	x		0.305		A,
	Green	y		0.578		A,
	Blue	x		0.150		A,
	Blue	y		0.127		A,
	White	x		0.313		A,
	White	y		0.329		A,
White Luminance [cd/m ²]	ICCFL=6.0mA		180	220	--	Center A, E
Luminance Uniformity	ICCFL=6.0mA, 13points		65	--	--	A, F
	ICCFL=6.0mA, 5points		80	--	--	

Note: A. Measurement Setup:

The LCD module should be stabilized at given temperature for 20 minutes to avoid abrupt temperature change during measuring. In order to stabilize the luminance, the measurement should be executed after lighting backlight for 20 minutes in a windless room.



InfoVision Optoelectronics (Kunshan) Co.,LTD.

Document Title	M156NWR1 R0 Product Information			Page No.	9/32
Document No.		Issue date	2009/10/08	Revision	V02

Figure 5 Measurement Setup

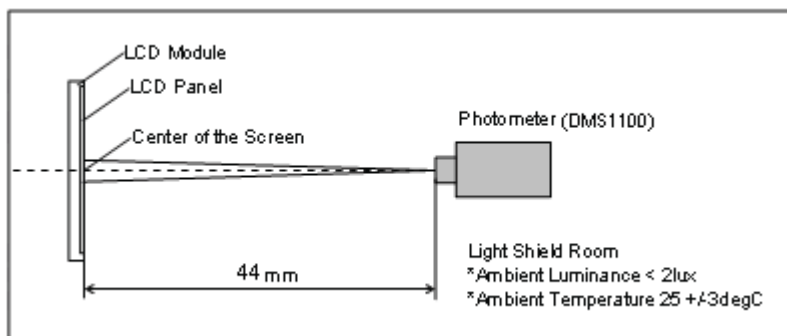

B. Definition of Viewing Angle

Figure 6 Definition of Viewing Angle

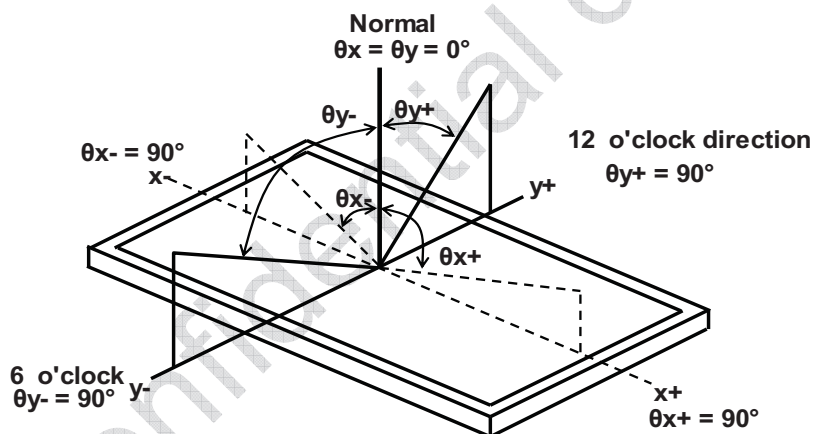

C. Definition of Contrast Ratio (CR)

The contrast ratio can be calculated by the following expression

$$\text{Contrast Ratio (CR)} = L_{63} / L_0$$

L63: Luminance of gray level 63, L0: Luminance of gray level 0



InfoVision Optoelectronics (Kunshan) Co.,LTD.

Document Title	M156NWR1 R0 Product Information			Page No.	10/32
Document No.		Issue date	2009/10/08	Revision	V02

D. Definition of Response Time (T_R , T_F)

Figure 7 Definition of Response Time

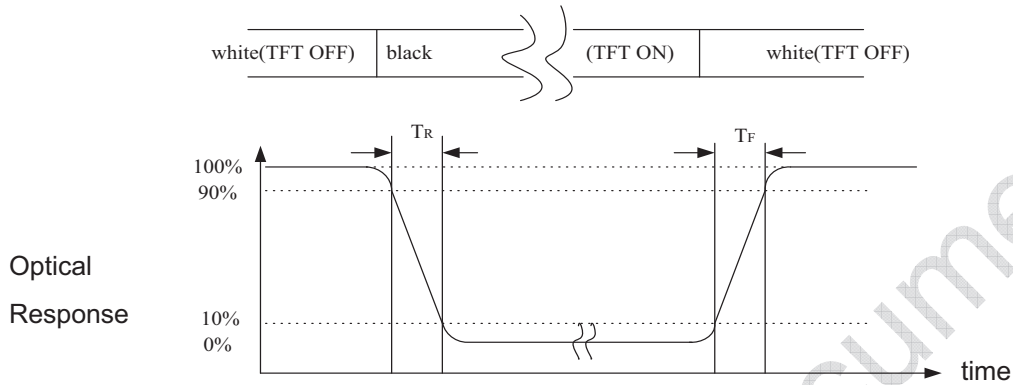

E. Definition of Luminance White

Measure the luminance of gray level 63 at center point

F. Definition of Luminance Uniformity(Variation)

Measure the luminance of gray level 63 at 13 points.

$$UNF(13pts) = \frac{\max(L1,L2,\dots,L13)}{\min(L1,L2,\dots,L13)} \quad UNF(5pts) = \frac{\max(L1,L2,\dots,L5)}{\min(L1,L2,\dots,L5)}$$

Figure 8 Measurement Locations of 13 Points

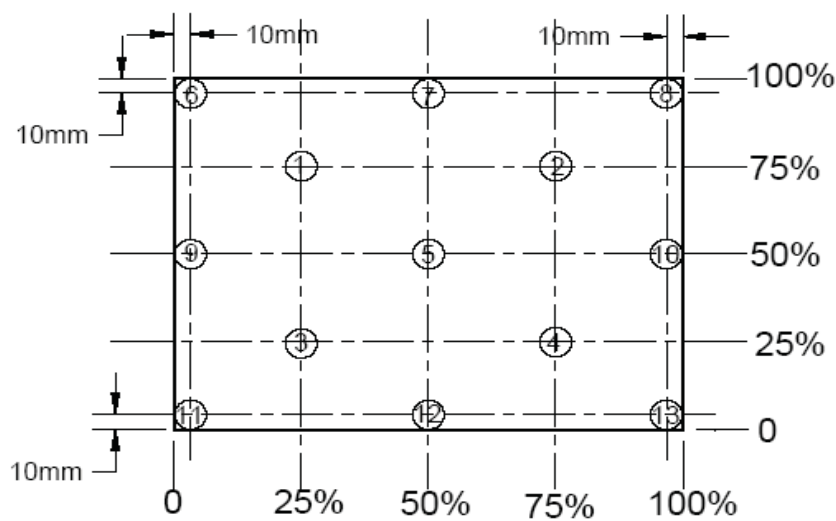

Screen Uniformity Measurement Points (13)



InfoVision Optoelectronics (Kunshan) Co.,LTD.

Document Title	M156NWR1 R0 Product Information			Page No.	11/32
Document No.		Issue date	2009/10/08	Revision	V02

5.0 Backlight Characteristics

5.1 CCFL Connector

Table 2 Connector Name / Designation

Manufacturer	JST
Type / Part Number	BHSR-02VS-1 OR equivalent
Mating Type / Part Number	SM02B-BHSS-1-TB OR equivalent

Table 3 Signal assignment

Pin #	Signal Name
1	Lamp High Voltage
2	Lamp Low Voltage

5.2 Parameter Guideline for CCFL Inverter

Table 4 Parameter guideline for CCFL Inverter

SYMBOL	PARAMETER	MIN	Design Point	MAX	UNITS	CONDITION
ICCFL	CCFL current	2.0	6.0	7.0	[mA _{rms}]	Ta=25[deg C] (Note A)
FCCFL	CCFL Frequency	45	60	80	[kHz]	Ta=25[deg C] (Note B)
VCCFLi	Inverter Ignition Voltage	--	--	1,610	[V _{rms}]	Ta=0[deg C] (Note C)
		--	--	1,290	[V _{rms}]	Ta=25[deg C] (Note C)
VCCFL	CCFL Voltage	681	703	725	[V _{rms}]	@ ICCFL=6mA Ta=25[deg C]
LT	Lamp Life Time	12,000	--	--	Hours	(Note E)

Note:

- If it exceeds MIN/MAX values, then "CCFL Life", "ON/OFF Cycle", and "SAFETY" will not be guaranteed.
- CCFL Frequency should be carefully determined to avoid interference between inverter and TFT LCD.
- The voltage over specified value (VCCFLi) should be applied to the lamp more than 1 second after startup. Otherwise, the lamp may not be turned on. The used lamp current is the lamp typical current.



InfoVision Optoelectronics (Kunshan) Co.,LTD.

Document Title	M156NWR1 R0 Product Information			Page No.	12/32
Document No.		Issue date	2009/10/08	Revision	V02

D. The distortion rate of the waveform should be within $\sqrt{2}\pm 10\%$

The inverter output waveform should be better similar to the ideal sine wave.

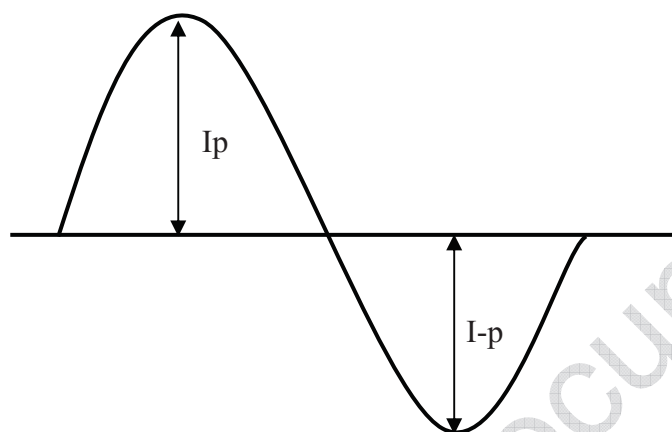

$$\text{Asymmetry rate} = \frac{|I_p - I-p|}{I_{rms}} \times 100\%$$

$$\text{Distortion rate} = \frac{I_p \text{ (or } I-p)}{I_{rms}}$$

Figure 9 Recommendation of Lighting Waveform

E. $T_a = 25 \pm 3 \text{ degC}$ and $ICCFL = 6.0 \text{ mA}$, brightness becomes lower than 50% of initial value.



InfoVision Optoelectronics (Kunshan) Co.,LTD.

Document Title	M156NWR1 R0 Product Information			Page No.	13/32
Document No.		Issue date	2009/10/08	Revision	V02

6.0 Electrical Characteristics

6.1 Interface Connector

Table 5 Connector Name / Designation

Manufacturer	HRS (or equivalent)
Type / Part Number	MDF76KBRW-30S-1H(58)
Mating Receptacle/Part Number	JAE FI-X30H(L), JAE FI-X30C*(L), JAE FI-X30M*

Table 6 Signal pin assignment

Pin #	Signal Name	Description	Remarks
1	Vss	Ground	
2	Vdd	Power supply 3.3V	
3	Vdd	Power supply 3.3V	
4	V _{EEDID}	DDC 3.3V power	
5	Tp	TEST point	
6	CLK _{EEDID}	DDC clock	
7	Data _{EEDID}	DDC data	
8	Odd Rin 0-	LVDS differential data input	
9	Odd Rin 0+	LVDS differential data input	
10	Vss	Ground	
11	Odd Rin 1-	LVDS differential data input	
12	Odd Rin 1+	LVDS differential data input	
13	Vss	Ground	
14	Odd Rin 2-	LVDS differential data input	
15	Odd Rin 2+	LVDS differential data input	
16	Vss	Ground	
17	Odd Clk in -	LVDS differential clock input	
18	Odd Clk in +	LVDS differential clock input	
19	Vss	Ground	
20	NC	Not connected	
21	NC	Not connected	
22	GND	GND	
23	NC	Not connected	
24	NC	Not connected	
25	GND	GND	
26	NC	Not connected	



InfoVision Optoelectronics (Kunshan) Co.,LTD.

Document Title	M156NWR1 R0 Product Information			Page No.	14/32
Document No.		Issue date	2009/10/08	Revision	V02

27	NC	Not connected	
28	GND	GND	
29	NC	Not connected	
30	NC	Not connected	

All input signals shall be low or Hi-Z state when VDD is off.

6.2 LVDS Receiver

6.2.1 Signal Electrical Characteristics for LVDS Receiver

The built-in LVDS receiver is compatible with (ANSI/TIA/TIA-644) standard.

Table 7 LVDS Receiver Electrical Characteristics

Parameter	Symbol	Min	Typ	Max	Unit	Conditions
Differential Input High Threshold	Vth	--	--	+100	mV	Vcm=+1.2V
Differential Input Low Threshold	Vtl	-100	--	--	mV	Vcm=+1.2V
Magnitude Differential Input Voltage	Vid	100	--	600	mV	--
Common Mode Voltage	Vcm	Vid /2+0.6	1.2	1.8- Vid /2	V	--
Common Mode Voltage Offset	ΔV_{cm}	--	--	50	mV	Vcm=+1.2V

Note:

- Input signals shall be low or Hi-Z state when VDD is off.
- All electrical characteristics for LVDS signal are defined and shall be measured at the interface connector of LCD.

Table 10 Timing Requirements

Parameter	Symbol	Min	Typ	Max	Unit	Conditions	Note
Clock Frequency	Fc	50	75	85	MHz		
Input Data Skew Margin	Trskm	640 520	--	--	ps ps	Fclk=68MHz Fclk=82MHz	(Figure 14)

Note: All values are at VDD=3.3V, Ta=25 degree C.



InfoVision Optoelectronics (Kunshan) Co.,LTD.

Document Title	M156NWR1 R0 Product Information			Page No.	15/32
Document No.		Issue date	2009/10/08	Revision	V02

Figure 11 Voltage Definitions

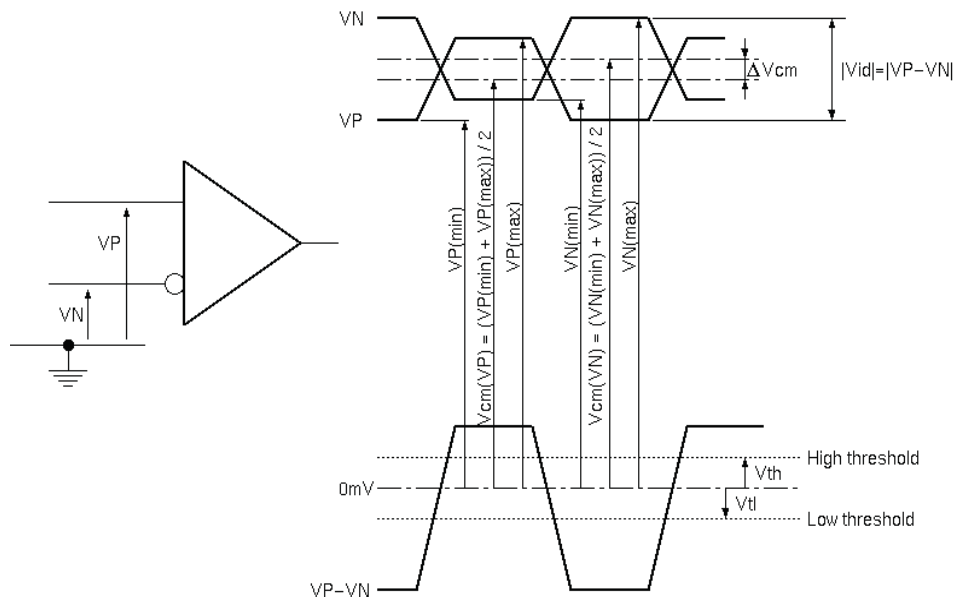
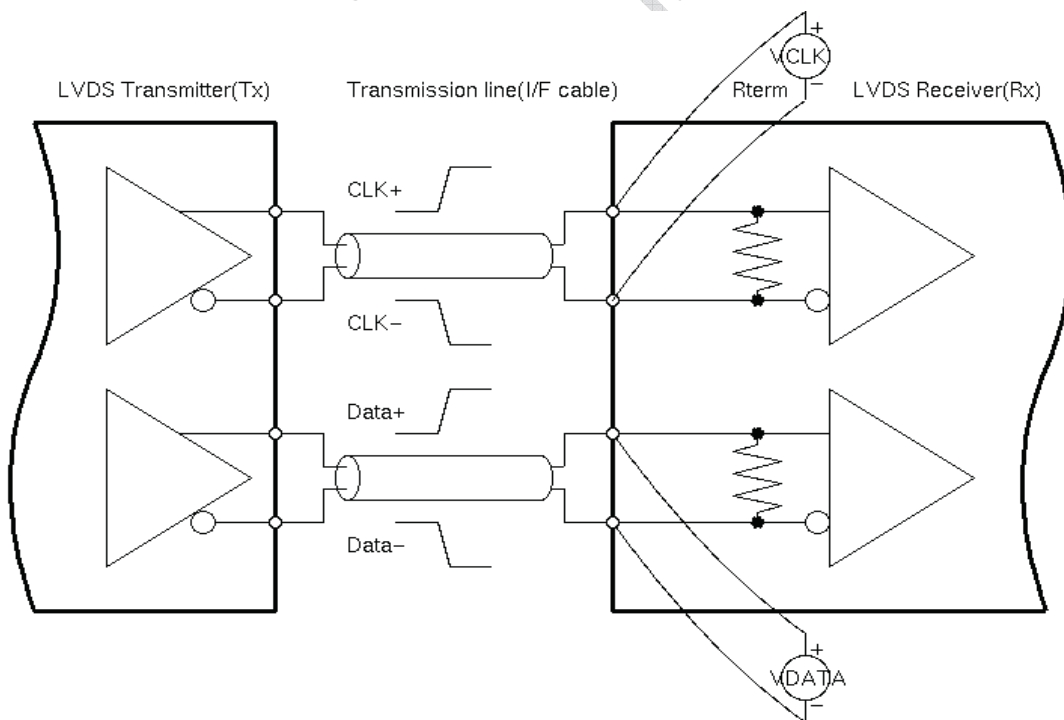

Figure 12 Measurement System





InfoVision Optoelectronics (Kunshan) Co.,LTD.

Document Title	M156NWR1 R0 Product Information			Page No.	16/32
Document No.		Issue date	2009/10/08	Revision	V02

Figure 13 Data mapping

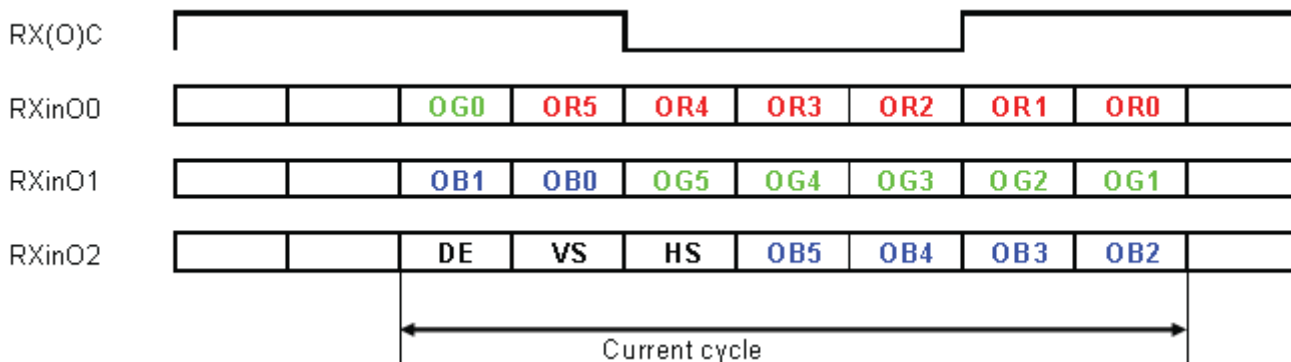
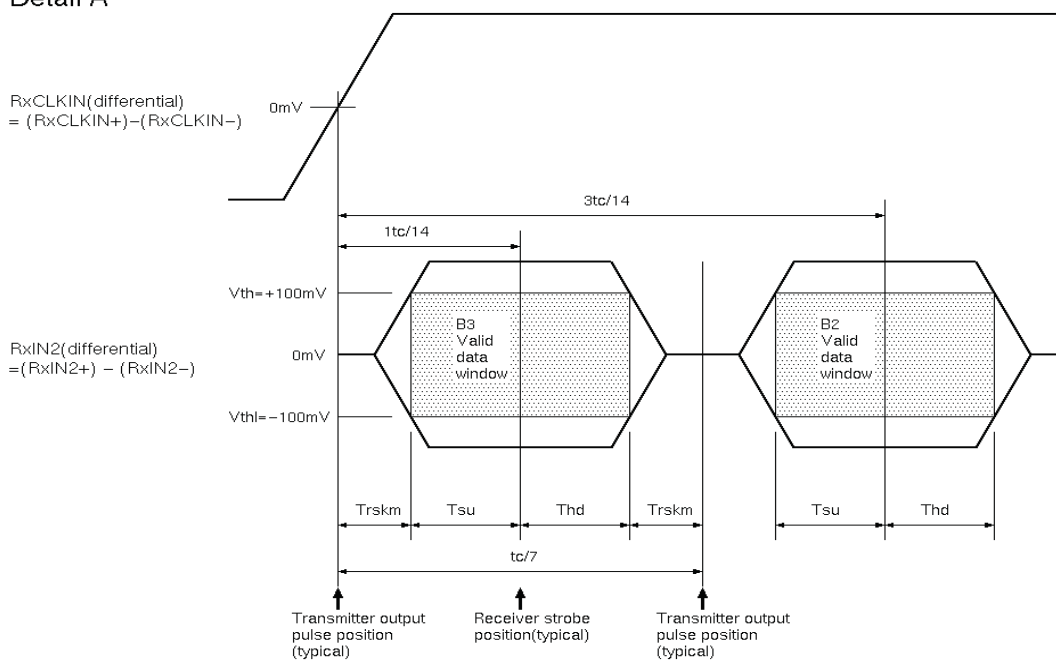

Figure 14 Timing Definition

Detail A



Note: Tsu and Thd is internal data sampling window of receiver. Trskm is the system skew margin; i.e., the sum of cable skew, source clock jitter, and other inter-symbol interference, shall be less than Trskm.



InfoVision Optoelectronics (Kunshan) Co.,LTD.

Document Title	M156NWR1 R0 Product Information			Page No.	17/32
Document No.		Issue date	2009/10/08	Revision	V02

6.2.2 LVDS Receiver Internal Circuit

Figure 15 LVDS Receiver Internal Circuit shows the internal block diagram of the LVDS receiver. This LCD module equips termination resistors for LVDS link.

Figure 15 LVDS Receiver Internal Circuit

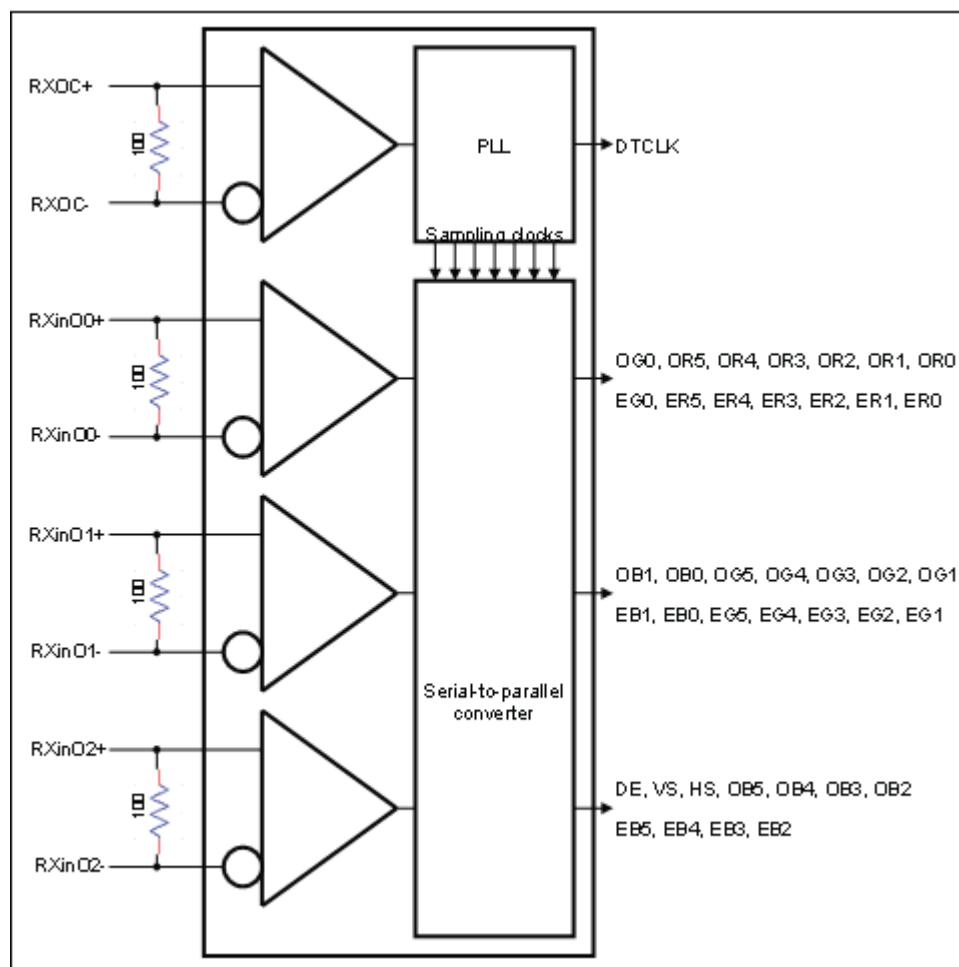



InfoVision Optoelectronics (Kunshan) Co.,LTD.

Document Title	M156NWR1 R0 Product Information			Page No.	18/32
Document No.		Issue date	2009/10/08	Revision	V02

7.0 Interface Timings

Table 16 Timing Characteristics

Parameter	Symbol	Unit	min	typ	Max
LVDS Clock Frequency(single)	Fdck	MHz	50	75	85
H Total Time	Htotal	clocks	1,446	1,560	1,936
H Active Time	Hac	clocks	1,366	1,366	1,366
V Total Time	Vtotal	lines	778	806	888
V Active Time	Vac	lines	768	768	768
Frame Rate	Vsync	Hz	55	60	65

Note (1) This product is DE only mode. The input of Hsync & Vsync signal does not have an effect on normal operation.

(2) Internal Vcc= 3.3V.



InfoVision Optoelectronics (Kunshan) Co.,LTD.

Document Title	M156NWR1 R0 Product Information			Page No.	19/32
Document No.		Issue date	2009/10/08	Revision	V02

Figure 17 Timing Characteristics

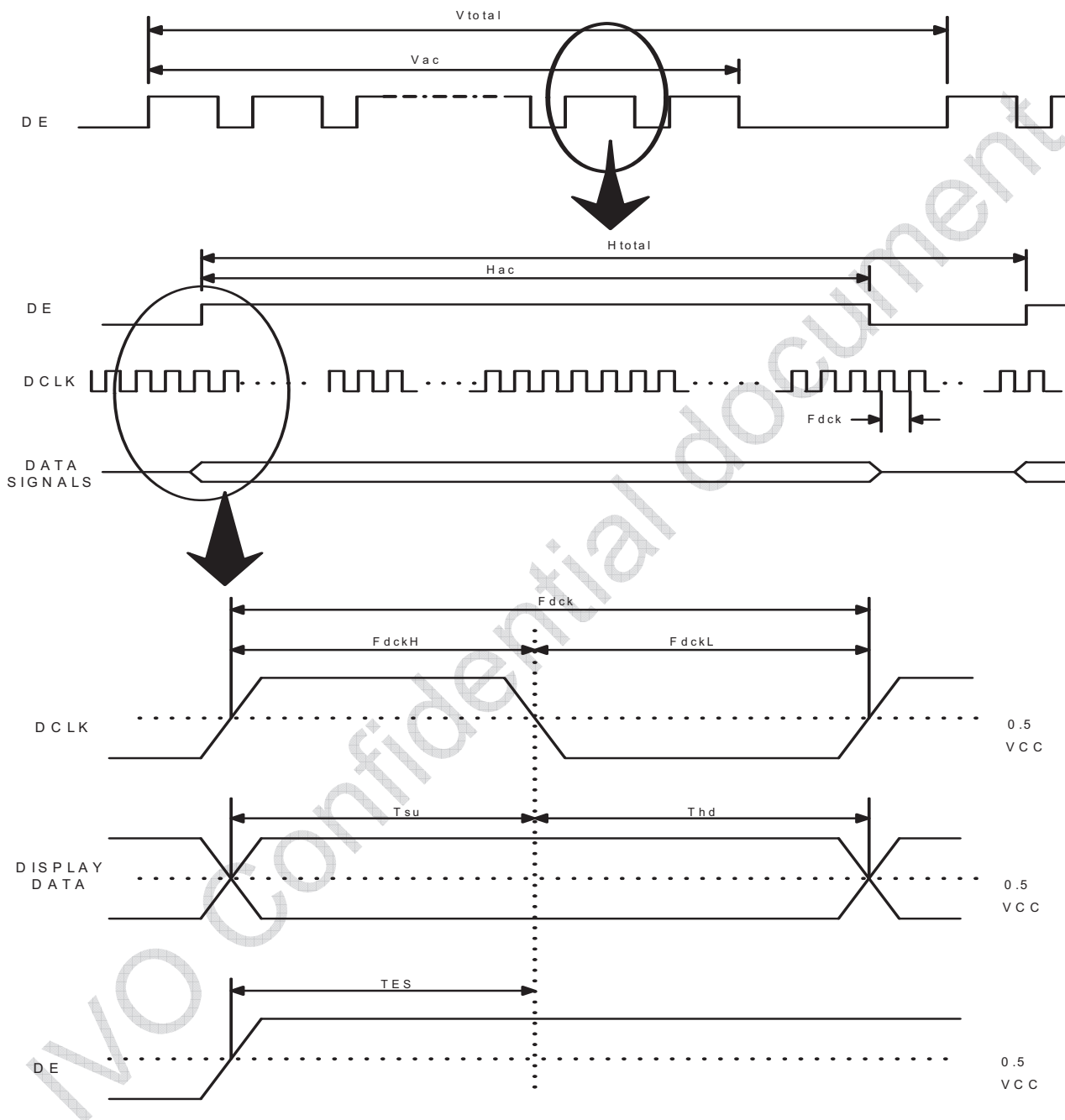

Note: TES is data enable signal setup time.



InfoVision Optoelectronics (Kunshan) Co.,LTD.

Document Title	M156NWR1 R0 Product Information			Page No.	20/32
Document No.		Issue date	2009/10/08	Revision	V02

8.0 Power Consumption

Input power specifications are as follows.

Table 8 Power consumption

SYMBOL	PARAMETER	Min	Typ	Max	UNITS	CONDITION
VDD	Logic/LCD Drive Voltage	3.0	3.3	3.6	[V]	
IDD	VDD Current	0.43	0.47	--	[A]	All black pattern, 60Hz
		0.47	0.49	0.53	[A]	Max pattern, 60Hz
PDD	VDD Power	--	5.6	7.0	[W]	All black pattern, 60Hz
Irush	Rush Current	--	--	2	[A]	Vdd rising time over 0.5ms.Oscilloscope Sampling over 2ms
VDDrp	Allowable Logic/LCD Drive Ripple Voltage	--	--	200	[mVp-p]	



InfoVision Optoelectronics (Kunshan) Co.,LTD.

Document Title	M156NWR1 R0 Product Information			Page No.	21/32
Document No.		Issue date	2009/10/08	Revision	V02

9.0 Power ON/OFF Sequence

VDD power, interface signals, and lamp on/off sequence are shown in Figure 18. Signals shall be Hi-Z state or low level when VDD is off.

Figure 18 Power sequence

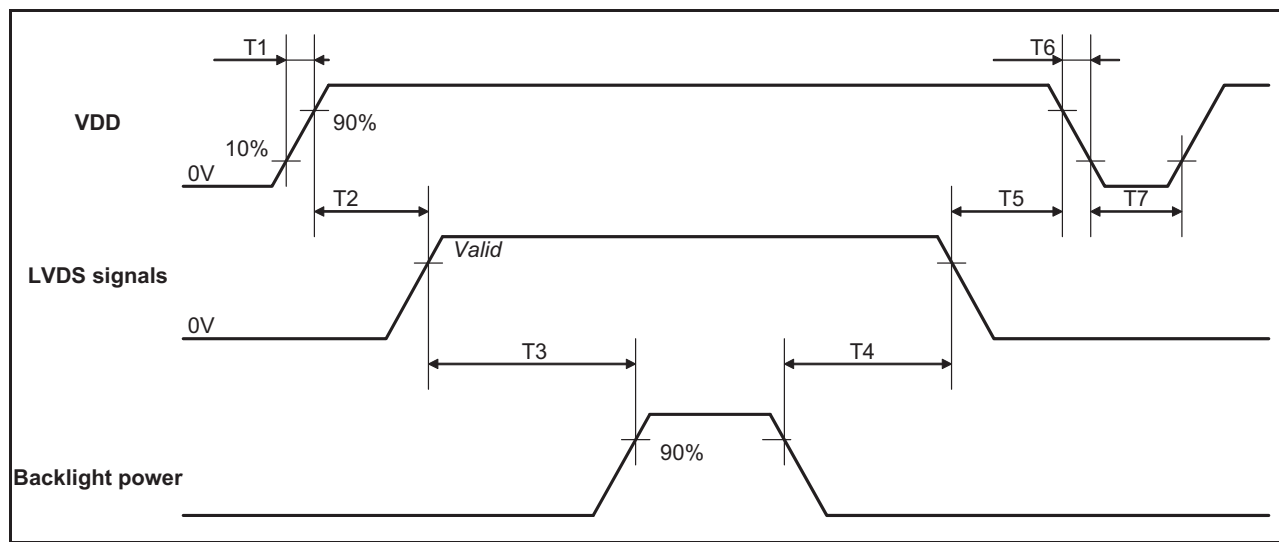
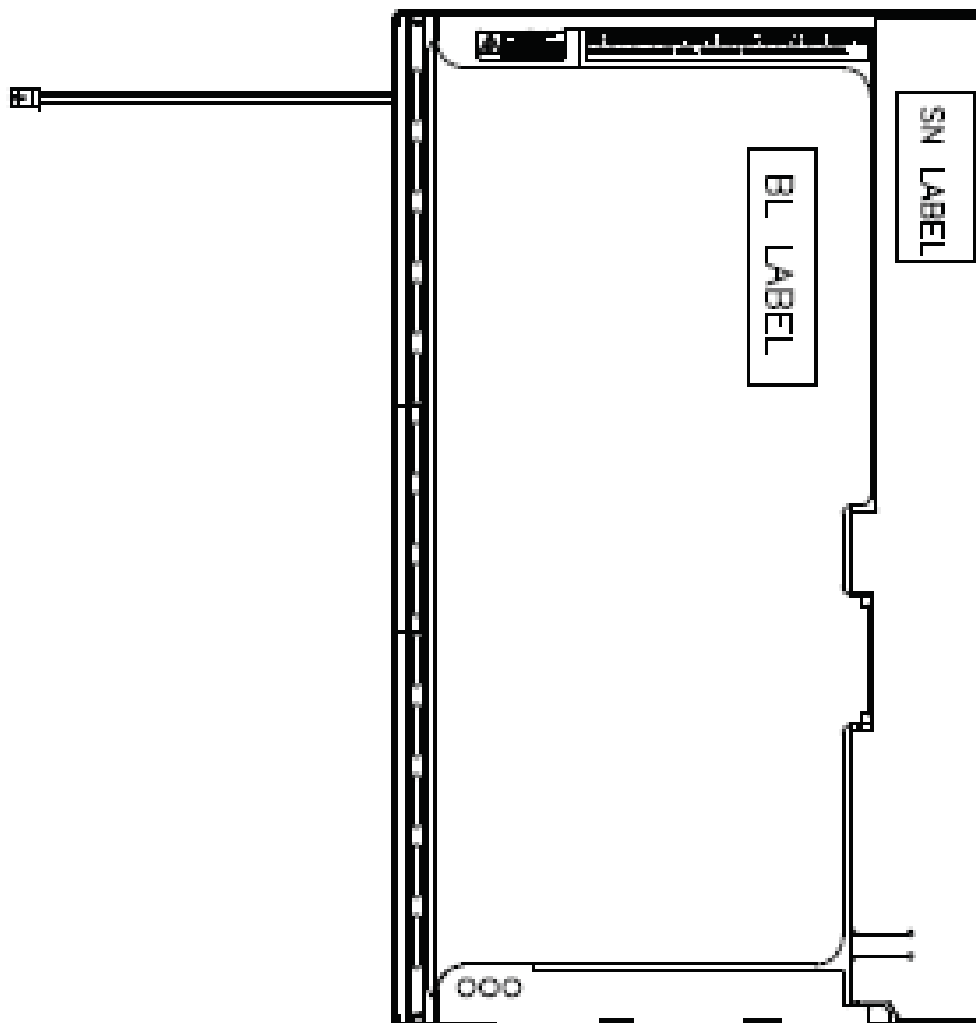

Table 9 Power Sequencing Requirements

Parameter	Symbol	Unit	min	typ	max
VDD Rise Time	T1	ms	0.5	--	10
VDD Good to Signal Valid	T2	ms	0	--	50
Signal Valid to Backlight On	T3	ms	200	--	--
Backlight Off to Signal Disable	T4	ms	200	--	--
Signal Disable to Power Down	T5	ms	0	--	50
VDD Fall Time	T6	ms	0	--	10
Power Off	T7	ms	200	--	--

**InfoVision Optoelectronics (Kunshan) Co.,LTD.**

Document Title	M156NWR1 R0 Product Information			Page No.	23/32
Document No.		Issue date	2009/10/08	Revision	V02

Figure 20 Reference outline drawing (Back side)



InfoVision Optoelectronics (Kunshan) Co.,LTD.

Document Title	M156NWR1 R0 Product Information			Page No.	24/32
Document No.		Issue date	2009/10/08	Revision	V02

10.1 Dimension Specifications

Table 10 Module Dimension Specifications

Width [mm]		359.3±0.5
Height [mm]		209.5±0.5
Thickness [mm]		6.0±0.3
Bezel Opening [mm]	X	347.93±0.3
	Y	196.94±0.3
Mounting Hole [mm]	A	11.9±0.3
	B	66.9±0.3
	C	118.8±0.3
	D	185.7±0.3
Module edge from Pin 1[mm]	X	110.6±1.0
Connector from first customer hole[mm]	Y	32.0±1.0
CCFL harness length [mm]		120±5.0
Weight [g]		550max
BM : a-b & c-d		≤1.0mm

Figure 21 Module Dimension

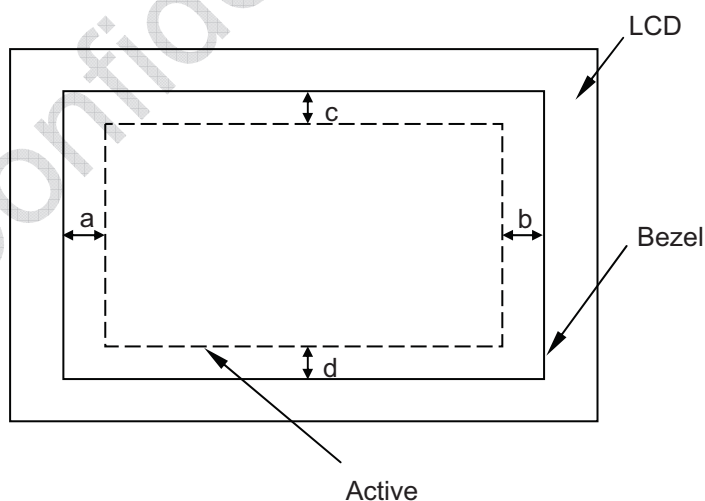



InfoVision Optoelectronics (Kunshan) Co.,LTD.

Document Title	M156NWR1 R0 Product Information			Page No.	25/32
Document No.		Issue date	2009/10/08	Revision	V02

11.0 Package Specification

The outside dimension of carton is 455(L)mm*380(W)mm*355(H)mm

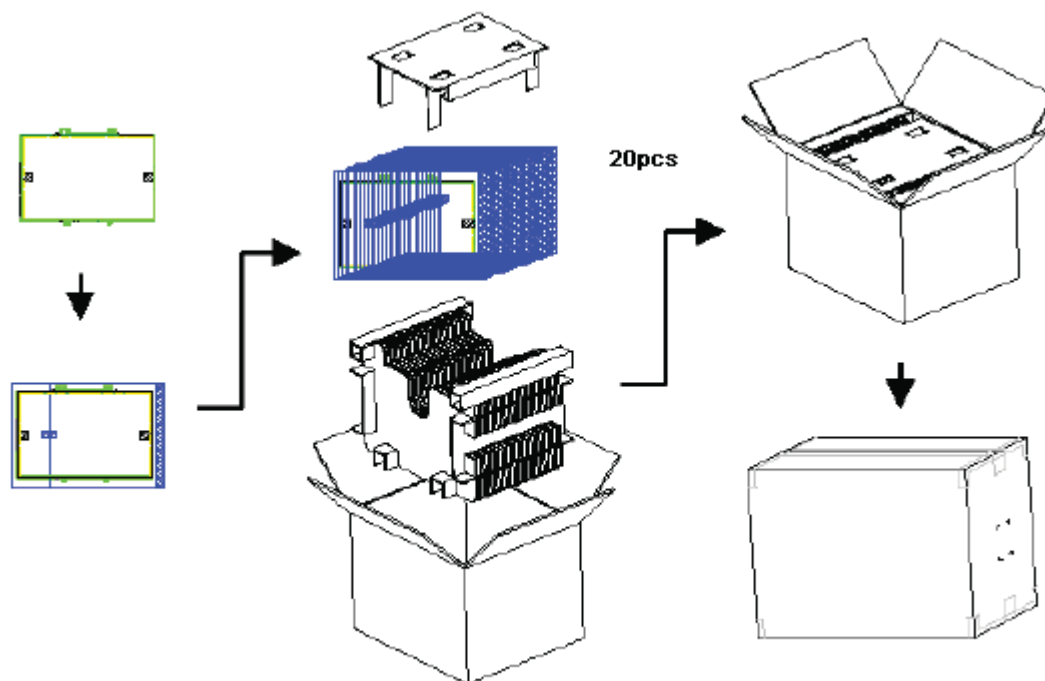

Figure 22 Packing Method



InfoVision Optoelectronics (Kunshan) Co.,LTD.

Document Title	M156NWR1 R0 Product Information			Page No.	26/32
Document No.		Issue date	2009/10/08	Revision	V02

12.0 Lot Mark

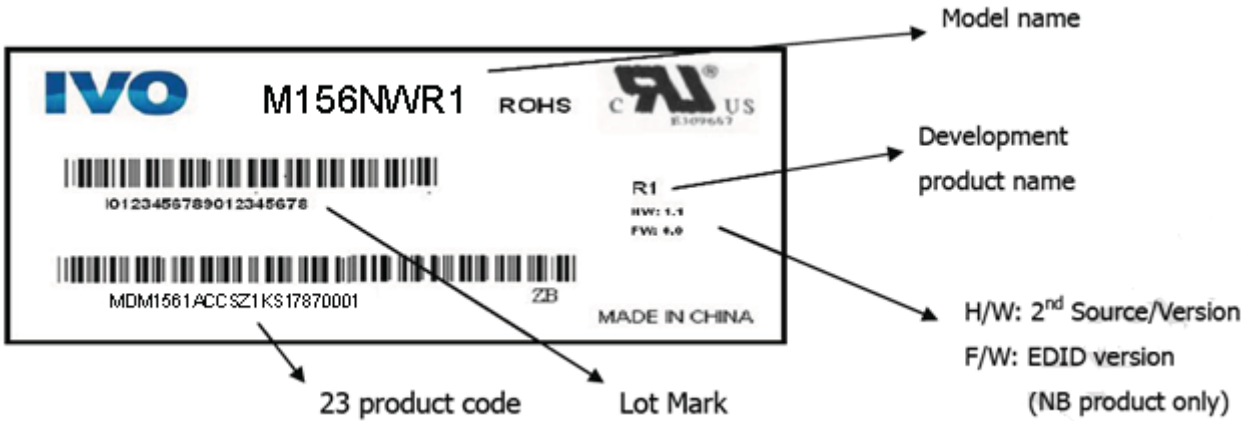

12.1 Lot Mark

1	2	3	4	5	6	7	8	9	10	11	12	13	14	15	16	17	18	19	20
---	---	---	---	---	---	---	---	---	----	----	----	----	----	----	----	----	----	----	----

code 1,2,4,5,6,7,8,9,10,11,16: IVO internal flow control code.
 code 3: production location.
 code 12: production year.
 code 13: production month.
 code 14,15: production date.
 Code 17,18,19,20: serial number.

Note (1) Production Year

Year	2006	2007	2008	2009	2010	2011	2012	2013	2014	2015
Mark	6	7	8	9	A	B	C	D	F	G

Note (2) Production Month

Month	Jan.	Feb.	Mar.	Apr.	May.	Jun.	Jul.	Aug.	Sep.	Oct	Nov.	Dec.
Mark	1	2	3	4	5	6	7	8	9	A	B	C

12.2 23 product barcode

1	2	3	4	5	6	7	8	9	10	11	12	13	14	15	16	17	18	19	20	21	22	23
---	---	---	---	---	---	---	---	---	----	----	----	----	----	----	----	----	----	----	----	----	----	----

code 1,2: MD Mindtech Display.
 code 3,4,5,6,7: IVO internal module name.
 code 8,9,10,13,16: IVO internal flow control code.
 code 11,12: Cell location Suzhou defined as "SZ".
 code 14,15: Module line kunshan defined as "KS".
 code 17,18,19 : Year, Month, Day Refer to MTDIs barcode Note(1),Note(2).
 code 20~23 : Serial Number.



InfoVision Optoelectronics (Kunshan) Co.,LTD.

Document Title	M156NWR1 R0 Product Information			Page No.	27/32
Document No.		Issue date	2009/10/08	Revision	V02

13.0 General Precaution

13.1 Use Restriction

This product is not authorized for use in life supporting systems, aircraft navigation control systems, military systems and any other application where performance failure could be life-threatening or otherwise catastrophic.

13.2 Handling (Disassembling or Modification, Breakage of LCD panel, Electric Shock, Absolute Maximum Ratings and Power Protection Circuit, Operation, Mechanism, Station Electricity,)

- (1) Please mount LCD module by using mounting holes arranged in four corners tightly.
- (2) Do not disassemble or modify the module. It may damage sensitive parts inside LCD module, and may cause scratches or dust on the display. MTD does not warrant the module, if customers disassemble or modify the module.
- (3) If LCD panel is broken and liquid crystal spills out, do not ingest or inhale liquid Crystal, and do not contact liquid crystal with skin. If liquid crystal contacts mouth or eyes, rinse out with water immediately. If liquid crystal contacts skin or cloths, wash it off immediately with alcohol and Rinse thoroughly with water.
- (4) Disconnect power supply before handling LCD module. Do not pull or fold the CCFL cable. Do not touch the parts inside LCD modules and the fluorescent lamp's connector Or cables in order to prevent electric shock
- (5) Refrain from strong mechanical shock and /or any force to the module. In addition to damage, this may cause improper operation or damage to the module and CCFT back-light.
- (6) Do not exceed the absolute maximum rating values, such as the supply voltage variation, input voltage variation, variation in parts' parameters, environmental temperature; etc otherwise LCD module may be damaged. It's recommended employing protection circuit for power supply.
- (7) Do not touch, push or rub the polarizer with anything harder than HB pencil lead. Use fingerstalls of soft gloves in order to keep clean display quality, when Persons handle the LCD module for incoming inspection or assembly.
- (8) When the surface is dusty, please wipe gently with absorbent cotton or other soft Material. When cleaning the adhesives, please use absorbent cotton wetted with a little Petroleum benzene or other adequate solvent.
- (9) Wipe off saliva or water drops as soon as possible. If saliva or water drops Contact with polarizer for a long time, they may causes deformation or color Fading.
- (10) Protection film must remove very slowly from the surface of LCD module to Prevent from electrostatic occurrence.
- (11) Because LCD module uses CMOS-IC on circuit board and TFT-LCD panel, it is Very weak to electrostatic discharge, Please be careful with electrostatic Discharge .Persons who handle the module should be grounded through adequate methods.
- (12) Do not adjust the variable resistor located on the module.

13.3 Storage

- (1) Please do not leave LCD module in the environment of high humidity and high temperature for a long time.
- (2) The module shall not be exposed under strong light such as direct sunlight. Otherwise, Display characteristics may be changed.



InfoVision Optoelectronics (Kunshan) Co.,LTD.

Document Title	M156NWR1 R0 Product Information			Page No.	28/32
Document No.		Issue date	2009/10/08	Revision	V02

- (3) The module should be stored in a dark place. It is prohibited to apply sunlight or fluorescent light in storage.

13.4 Operation

- (1) Do not connect or disconnect the module in the "Power On" condition.
- (2) Power supply should always be turned on/off by 9.0 "Power on/off sequence"
- (3) Module has high frequency circuits. Sufficient suppression to the electromagnetic interference should be done by system manufacturers. Grounding and shielding methods may be important to minimize the interference.
- (4) The cable between the back-light connector and its inverter power supply should be connected directly with a minimized length. A longer cable between the back-light and the inverter may cause lower luminance of lamp(CCFT) and may require higher startup voltage(Vs).
- (5) After installation of the TFT Module into an enclosure, do not twist nor bend the TFT Module even momentary. At designing the enclosure, it should be taken into consideration that no bending/twisting forces are applied to the TFT Module from outside. Otherwise the TFT Module may be damaged.

13.5 Others

- (1) Ultra-violet ray filter is necessary for outdoor operation.
- (2) Avoid condensation of water which may result in improper operation or disconnection of electrode.
- (3) If the module keeps displaying the same pattern for a long period of time, the image may be "sticked" to the screen.
- (4) This module has its circuitry PCB's on the rear side and should be handled carefully in order not to be stressed.

13.6 Disposal

When disposing LCD module, obey the local environmental regulations.



InfoVision Optoelectronics (Kunshan) Co.,LTD.

Document Title	M156NWR1 R0 Product Information			Page No.	29/32
Document No.		Issue date	2009/10/08	Revision	V02

14.0 EDID Data Structure

Table 11 EDID Table Format

Address (Decimal)	Address (HEX)	Field Name & Comments	Value (HEX)	Value (BIN)	Value (DEC)
0	0	Header	0	00000000	0
1	1		FF	11111111	255
2	2		FF	11111111	255
3	3		FF	11111111	255
4	4		FF	11111111	255
5	5		FF	11111111	255
6	6		FF	11111111	255
7	7		0	00000000	0
8	8	EISA Manuf. Code LSB (3 character ID = IVO)	26	00100110	38
9	9	Compressed ASCII	CF	11001111	207
10	0A	Product Code = 1561	19	00011001	25
11	0B	hex, LSB first	6	00000110	6
12	0C	32-bit serial #	0	00000000	0
13	0D		0	00000000	0
14	0E		0	00000000	0
15	0F		0	00000000	0
16	10	Week of manufacture	0	00000000	0
17	11	Year of manufacture 2008	12	00010010	18
18	12	EDID Structure Ver # = 1	1	00000001	1
19	13	EDID revision # = 3	3	00000011	3
20	14	Video input definition = Digital input	80	10000000	128
21	15	Max H image size = 34.4 cm	22	00100010	34
22	16	Max V image size = 19.3 cm	13	00010011	19
23	17	Display Gamma = 2.2	78	01111000	120
24	18	Feature support (DPMS) = Active off, RGB color	A	00001010	10
25	19	Red/Green Low bits (RxRy/GxGy)	73	01110011	115
26	1A	Blue/White Low bits (BxBY/WxWy)	60	01100000	96
27	1B	Red X Rx=0.646	A5	10100101	165
28	1C	Red Y Ry=0.339	56	01010110	86



InfoVision Optoelectronics (Kunshan) Co.,LTD.

Document Title	M156NWR1 R0 Product Information			Page No.	30/32
Document No.		Issue date	2009/10/08	Revision	V02

29	1D	Green X Gx=0.305	4E	01001110	78
30	1E	Green Y Gy=0.578	93	10010011	147
31	1F	Blue X Bx=0.150	26	00100110	38
32	20	Blue Y By=0.127	20	00100000	32
33	21	White X Wx=0.313	50	01010000	80
34	22	White Y Wy=0.329	54	01010100	84
35	23	Established timing 1	0	00000000	0
36	24	Established timing 2 (1280x800 @ 60Hz)	0	00000000	0
37	25	Manufacturer's timings	0	00000000	0
38	26	Standard timing #1 was not used	1	00000001	1
39	27		1	00000001	1
40	28	Standard timing #2 was not used	1	00000001	1
41	29		1	00000001	1
42	2A	Standard timing #3 was not used	1	00000001	1
43	2B		1	00000001	1
44	2C	Standard timing #4 was not used	1	00000001	1
45	2D		1	00000001	1
46	2E	Standard timing #5 was not used	1	00000001	1
47	2F		1	00000001	1
48	30	Standard timing #6 was not used	1	00000001	1
49	31		1	00000001	1
50	32	Standard timing #7 was not used	1	00000001	1
51	33		1	00000001	1
52	34	Standard timing #8 was not used	1	00000001	1
53	35		1	00000001	1
54	36	Detailed timing/monitor descriptor#1	78	01111000	120
55	37	1366x768 @ 60Hz : Pixel Clock = 75 MHz	1D	00011101	29
56	38	Hor active=1366 pixels	56	01010110	86
57	39	Hor blanking=194 pixels	C2	11000010	194
58	3A	Horizontal Active : Horizontal Blanking	50	01010000	80
59	3B	Vertical active= 768 line	0	00000000	0
60	3C	Vertical blanking=38 ines	26	00100110	38
61	3D	Vertical Active : Vertical Blanking	30	00110000	48



InfoVision Optoelectronics (Kunshan) Co.,LTD.

Document Title	M156NWR1 R0 Product Information			Page No.	31/32
Document No.		Issue date	2009/10/08	Revision	V02

62	3E	H sync. Offset= 48 pixels	30	00110000	48
63	3F	H sync. Width=32 pixels	20	00100000	32
64	40	V sync. Offset= 3 lines	3C	00111100	60
65	41	V sync. Width= 12 lines	0	00000000	0
66	42	H image size= 344mm	58	01011000	88
67	43	V image size =193 mm	C1	11000001	193
68	44	Horizontal & Verical Image Size(344:193)	10	00010000	16
69	45	No Horizontal Border	0	00000000	0
70	46	No Vertical Border	0	00000000	0
71	47	Non-interlaced, Normal display, No stereo, Digital	18	00011000	24
72	48	Detailed timing/monitor descriptor#2	0	00000000	0
73	49		0	00000000	0
74	4A		0	00000000	0
75	4B		0F	00001111	15
76	4C		0	00000000	0
77	4D		0	00000000	0
78	4E		0	00000000	0
79	4F		0	00000000	0
80	50		0	00000000	0
81	51		0	00000000	0
82	52		0	00000000	0
83	53		0	00000000	0
84	54		0	00000000	0
85	55		0	00000000	0
86	56		0	00000000	0
87	57		0	00000000	0
88	58		0	00000000	0
89	59	Module revision	1	00000001	1
90	5A	Detailed timing/monitor descriptor#3	0	00000000	0
91	5B	Flag	0	00000000	0
92	5C	Flag	0	00000000	0
93	5D	Data Type Tag : Module serial number	FE	11111110	254
94	5E		0	00000000	0



InfoVision Optoelectronics (Kunshan) Co.,LTD.

Document Title	M156NWR1 R0 Product Information			Page No.	32/32
Document No.		Issue date	2009/10/08	Revision	V02

95	5F	Manufacture l	49	01001001	73
96	60	Manufacture n	6E	01101110	110
97	61	Manufacture f	66	01100110	102
98	62	Manufacture o	6F	01101111	111
99	63	Manufacture V	56	01010110	86
100	64	Manufacture i	69	01101001	105
101	65	Manufacture s	73	01110011	115
102	66	Manufacture i	69	01101001	105
103	67	Manufacture o	6F	01101111	111
104	68	Manufacture n	6E	01101110	110
105	69		0A	00001010	10
106	6A		20	00100000	32
107	6B		20	00100000	32
108	6C	Detailed timing/monitor descriptor #4	0	00000000	0
109	6D		0	00000000	0
110	6E	Color LCD	0	00000000	0
111	6F		FE	11111110	254
112	70		0	00000000	0
113	71	Manufacture P/N M	4D	01001101	77
114	72	Manufacture P/N 1	31	00110001	49
115	73	Manufacture P/N 5	35	00110101	53
116	74	Manufacture P/N 6	36	00110110	54
117	75	Manufacture P/N N	4E	01001110	78
118	76	Manufacture P/N W	57	01010111	87
119	77	Manufacture P/N R	52	01010010	82
120	78	Manufacture P/N 1	31	00110001	49
121	79	Manufacture P/N	20	00100000	32
122	7A	Manufacture P/N R	52	01010010	82
123	7B	Manufacture P/N 0	30	00110000	48
124	7C		0A	00001010	10
125	7D		20	00100000	32
126	7E	Extension Flag = 00	0	00000000	0
127	7F	Checksum	A5	10100101	165