

AU OPTRONICS CORPORATION

Product Specification

17.0" SXGA Color TFT-LCD Module

Model Name: M170EG01 V.1

Approved by	Prepared by

DDBU Marketing Division / AU Optronics corporation

Customer	Checked & Approved by

Product Specification

17.0" SXGA Color TFT-LCD Module Model Name: M170EG01 V.1

(◆) Preliminary Specifications
(...) Final Specifications

Note: This Specification is subject to change without notice.

Contents

1.0 Handling Precautions	7
2.0 General Description	8
2.1 Display Characteristics	8
2.2 Functional Block Diagram	9
2.3 Optical Characteristics.....	10
2.4 Pixel format image	13
3.0 Electrical characteristics.....	14
3.1 Absolute Maximum Ratings.....	14
3.2 Connectors	15
3.3 Signal Pin.....	15
3.4 Signal Description	16
3.5 Signal Electrical Characteristics.....	19
3.6 Interface Timings	19
3.6.1 Timing Characteristics	19
3.6.2 Timing Definition	20
3.8 Power ON/OFF Sequence	22
4.0 Backlight Characteristics	23
4.1 Signal for Lamp connector	23
4.2 Parameter guideline for CCFL Inverter.....	23
5.0 Vibration, Shock, and Drop	24
5.1 Vibration & Shock	24
5.2 Drop test	24
6.0 Environment	24
6.1 Temperature and Humidity.....	24
6.1.1 Operating Conditions.....	24
6.1.2 Shipping Conditions	24
6.2 Atmospheric Pressure	25
6.3 Thermal Shock.....	25
7.0 Reliability	25
7.1 Failure Criteria	25
7.2 Failure Rate	25
7.2.1 Usage	25
8.0 Safety	26
8.1 Sharp Edge Requirements.....	26
8.2 Materials	26
8.2.1 Toxicity	26
8.2.2 Flammability	26

8.3 Capacitors	26
9.0 Other requirement.....	27
9.1 National Test Lab Requirement	27
9.2 Label	27
10.0 Mechanical Characteristics	28

Record of Revision

Version and Date	Page	Old description		New Description		Remark
0.1 2004/2/17	All	First Edition for Customer		All		
0.2 2004/2/27	8,14	Type P/N	FI-XB30SRL-HF11	Type P/N	FI-XB30SRL-HF11/ MDF76LBRW-30S- 1H	Modified
		Mating Housing P/N	HRS MDF76LBRW-30S- 1H (HIROSE)	Mating Housing P/N	JAE FI-X30C2L /HRS MDF76G-30P-1SD	
	9	Response time: Rising Time Typ = TBD Falling Time Typ = TBD		Response time: Rising Time Typ = 9ms Falling Time Typ = 3ms		Modified
	13	3.1 Absolute Maximum Ratings Vin Min=+4.5 , Max=+5.5		3.1 Absolute Maximum Ratings Vin Min=-0.3 , Max=+6		Modified
	16	3.4 Signal Description No note		Note1:Start from left side Note3: Please follow PSWG.		Added
	17	3.4 Signal Description Picture format		Follow PSWG		Modified
	20	LCD Inrush Current : TBD		LCD Inrush Current : 2.5 A		Modified
	9,11	No define		Flicker		Added
	18	3.5 Signal Electrical Characteristics		New definition		Modified
	18	Frame Rate Min = no definition		Frame Rate Min = 50Hz		Added
	20	VDD Current Typ=1100mA Max=1210mA		VDD Current Typ=1200mA Max=1560mA		Modified
	20	VDD Power Typ=5.5W Max=6.05W		VDD Power Typ=6W Max=7.8W		Modified
0.3 2004/4/1	9	2.2 Functional Block Diagram		CCFL connector 2pin x 2		Added
	14	3.1 Absolute Maximum Ratings		CCFL max. current = 8.5mA		Modified
	19	3.6.1 Timing Characteristics		DE mode only		Added
	23	4.2 Parameter guideline for CCFL Inverter		Note 1: The variance of the current is ±10%		Deleted
	23	4.2 Parameter guideline for CCFL Inverter		CCFL Ignition Voltage (End of the lamp wire connector)		Added

Product Specification

	23	4.2 Parameter guideline for CCFL Inverter Note4	The minimum lifetime of CCFL is on the condition at 7.5mA lamp current.	Added
0.3 2004/4/6	10	2.3 Optical Characteristics Response Time Max. = TBD	Rising Time Max. = 20 Falling Time Max. = 5 Rising + Falling Max. = 25	Modified
	10	2.3 Optical Characteristics White Luminance Min. = TBD	White Luminance Min. = 210	Modified
	9	2.2 Functional Block Diagram	Adding CCFL connector diagram	Added
	8	Contrast Ratio = TBD	Contrast Ratio = 450 : 1	Modified
	10	Contrast ratio Min. = TBD Contrast ratio Typ. = TBD	Contrast ratio Min. = 250 Contrast ratio Typ. = 450	Modified
0.3 2004/4/8	10,12	TC0-03 Compliance No defined	Note 5	Added
	9,15	3.2 Mating Type Part Number SM02(4.0)B-BHS-1-TB	Modified to SM02B-BHSS-1-TB	Modified

1.0 Handling Precautions

- 1) Since front polarizer is easily damaged, pay attention not to scratch it.
- 2) Be sure to turn off power supply when inserting or disconnecting from input connector.
- 3) Wipe off water drop immediately. Long contact with water may cause discoloration or spots.
- 4) When the panel surface is soiled, wipe it with absorbent cotton or other soft cloth.
- 5) Since the panel is made of glass, it may break or crack if dropped or bumped on hard surface.
- 6) Since CMOS LSI is used in this module, take care of static electricity and insure human earth when handling.
- 7) Do not open nor modify the Module Assembly.
- 8) Do not press the reflector sheet at the back of the module to any directions.
- 9) In case if a module has to be put back into the packing container slot after once it was taken out from the container, do not press the center of the CCFL reflector edge. Instead, press at the far ends of the CCFL reflector edge softly. Otherwise the TFT module may be damaged.
- 10) At the insertion or removal of the Signal Interface Connector, be sure not to rotate nor tilt the Interface Connector of the TFT module.
- 11) After installation of the TFT module into an enclosure (Desktop monitor Bezel, for example), do not twist nor bend the TFT Module even momentary. At designing the enclosure, it should be taken into consideration that no bending/twisting forces are applied to the TFT module from outside. Otherwise the TFT module may be damaged.

2.0 General Description

This specification applies to the 17.0 inch Color TFT/LCD Module M170EG01 V0.

This module is designed for a display unit of personal computer.

The display supports the SXGA (1280(H) x 1024(V)) screen format and 16.2M colors (RGB 6-bits + FRC data).

All input signals are 2 Channel LVDS interface compatible.

This module does not contain an inverter card for backlight.

2.1 Display Characteristics

The following items are characteristics summary on the table under 25 condition:

ITEMS	Unit	SPECIFICATIONS			
Screen Diagonal	[mm]	432(17.0")			
Active Area	[mm]	337.920 (H) x 270.336(V)			
Pixels H x V		1280(x3) x 1024			
Pixel Pitch	[mm]	0.264 (per one triad) x 0.264			
Pixel Arrangement		R.G.B. Vertical Stripe			
Display Mode		Normally White			
White Luminance	[cd/m ²]	260 (Typ)			
Contrast Ratio		450 : 1 (Typ)			
Optical Rise Time/Fall Time	[msec]	16 (Typ)			
Nominal Input Voltage VDD	[Volt]	+5.0 V			
Power Consumption (VDD line + CCFL line)	[Watt]	25.8 W(Typ) (PDD=6 W, PCFL=19.8 W @Lamp=7.5mA)			
Weight	[Grams]	1900 (Typ)			
Physical Size	[mm]		Min.	Typ.	Max.
		Horizontal(H)	358	358.5	359.0
		Vertical(V)	296	296.5	297
		Depth(D)	16.5	17.0	17.5
Electrical Interface		Dual Channel LVDS			
Support Color		16.2M colors (RGB 6-bit + FRC data)			
Temperature Range	[°C]	0 to +50			
	[°C]	-20 to +60			

2.2 Functional Block Diagram

The following diagram shows the functional block of the 17.0 inches Color TFT/LCD Module:

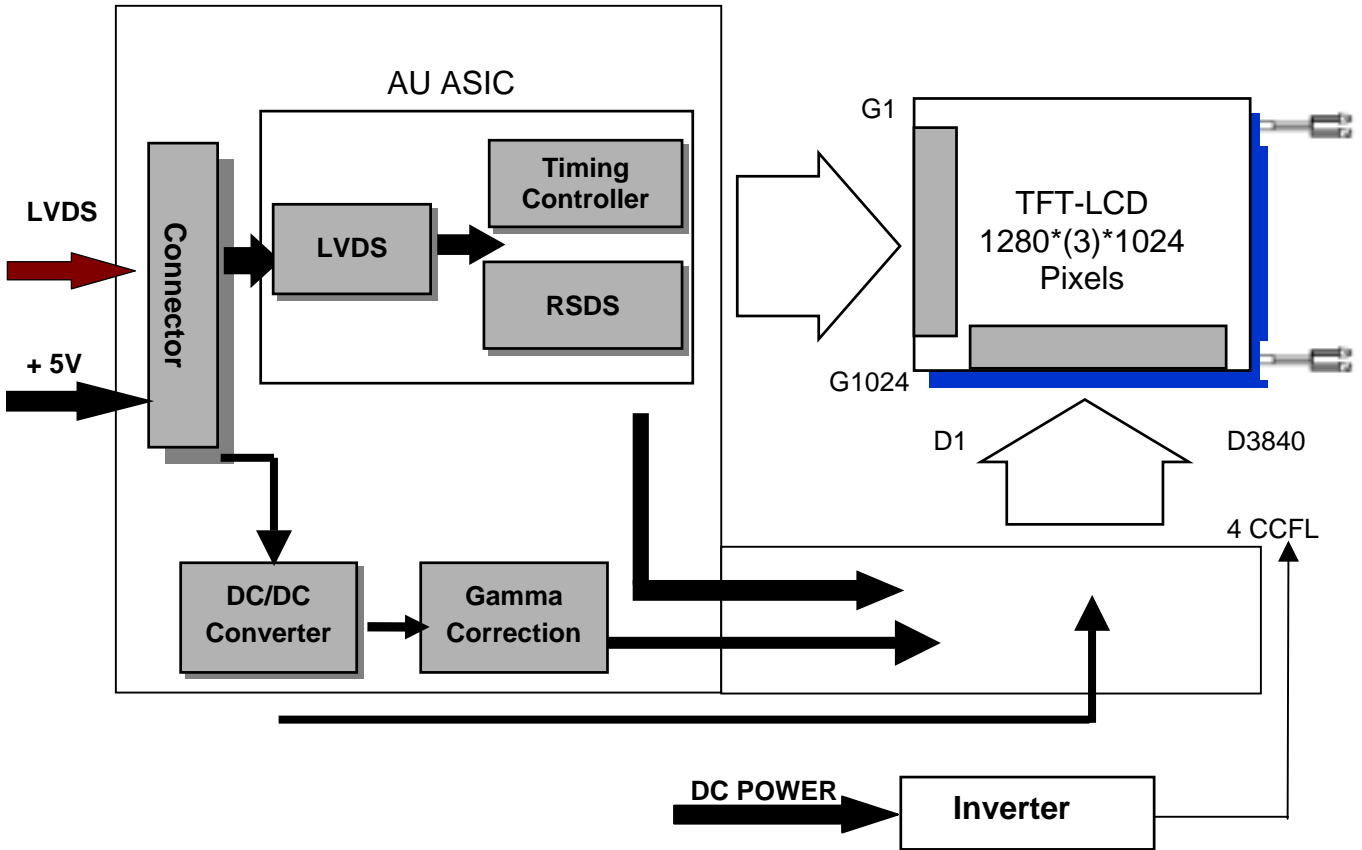

FI-XB30SRL-HF11 / MDF76LBRW-30S-1H

JST-BHSR-02VS-1 (2pin x 2)

Mating Type: JAE FI-X30C2L / HRS MDF76G-30P-1SD

SM02B-BHSS-1-TB

2.3 Optical Characteristics

The optical characteristics are measured under stable conditions at 25 (Room Temperature):

Item	Unit	Conditions	Min.	Typ.	Max.	Note
Viewing Angle	[degree]	Horizontal (Right) CR = 10 (Left)	60 60	70 70	-	-
		Vertical (Up) CR = 10 (Down)	60 60	70 70	-	-
		Normal Direction	250	450	-	-
Response Time	[msec]	Rising Time	-	12	20	Note 1
		Falling Time	-	4	5	
		Rising + Falling	-	16	25	
Color / Chromaticity Coordinates (CIE)		Red x	0.61	0.64	0.67	-
		Red y	0.31	0.34	0.37	-
		Green x	0.26	0.29	0.32	-
		Green y	0.58	0.61	0.64	-
		Blue x	0.11	0.14	0.17	-
		Blue y	0.04	0.07	0.10	-
Color Coordinates (CIE) White		White x	0.28	0.31	0.34	-
		White y	0.30	0.33	0.36	-
White Luminance @ CCFL 7.5mA (center)	[cd/m ²]		210	260		-
Luminance Uniformity	[%]		75	80		Note 2
Crosstalk (in 75Hz)	[%]				1.5	Note 3
Flicker	dB				-20	Note 4
TC0-03 Compliance						Note 5

Equipment: Pattern Generator, Power Supply, Digital Voltmeter, Luminance meter (PR 880, BM-5A / BM7)

Aperture 1 ° with 100cm VD or 2 ° with 50cm viewing distance
 Test Point Center (VESA point 9)
 Environment < 1 lux

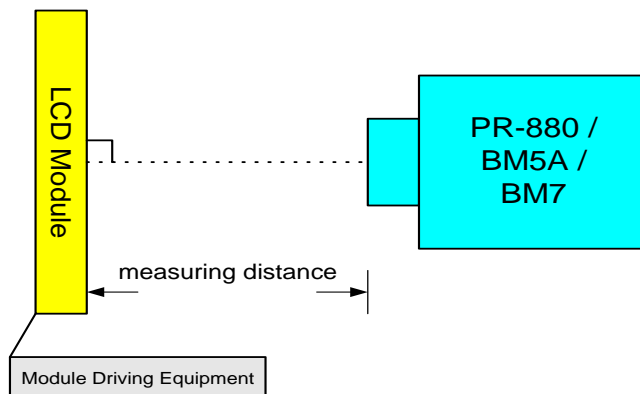

Note 1: Definition of Response time

The output signals of photodetector are measured when the input signals are changed from “Black” to “White” (rising time), and from “White” to “Black ”(falling time), respectively. The response time is interval between the 10% and 90% of amplitudes.

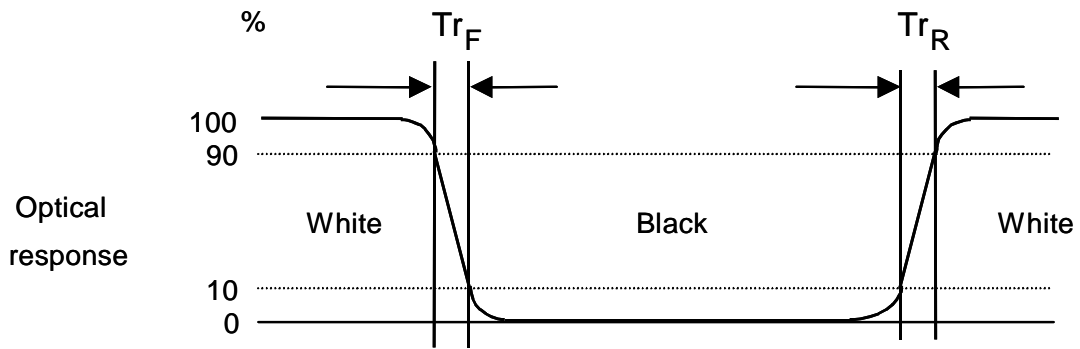

Note 2: Brightness uniformity of these 9 points is defined as below

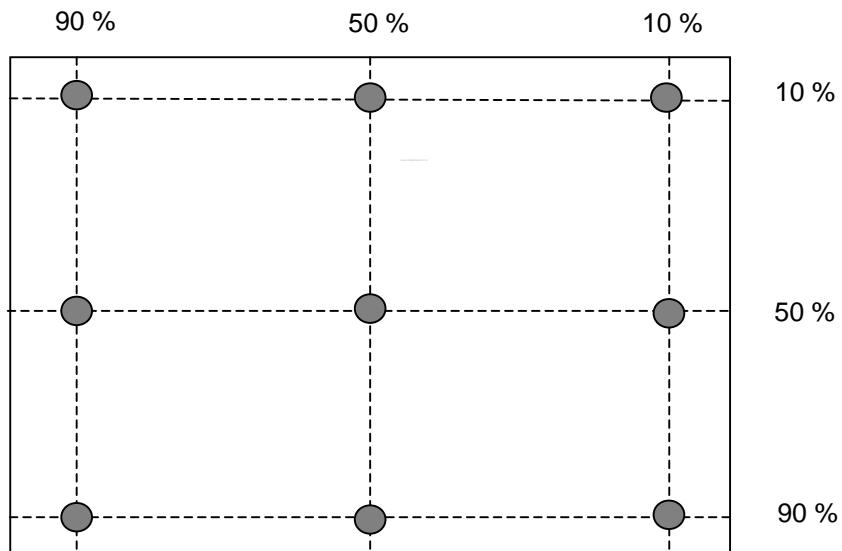

$$\text{Uniformity} = \frac{\text{Minimum Luminance in 9 points (1-9)}}{\text{Maximum Luminance in 9 Points (1-9)}}$$

Note 3:

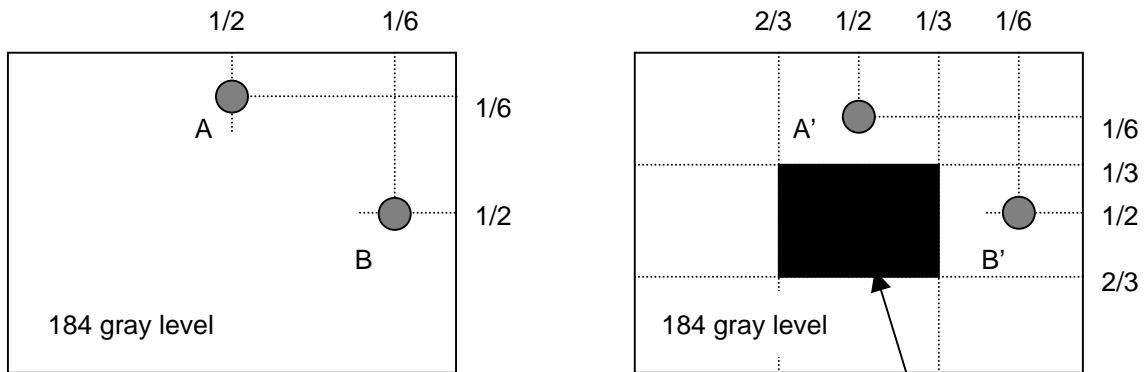

Unit: percentage of dimension of display area

$|L_A - L_{A'}| / L_A \times 100\% = 1.5\% \text{ max.}$, L_A and L_B are brightness at location A and B

$|L_B - L_{B'}| / L_B \times 100\% = 1.5\% \text{ max.}$, $L_{A'}$ and $L_{B'}$ are brightness at location A' and B'

Note4:

Test Pattern : Subchecker Pattern

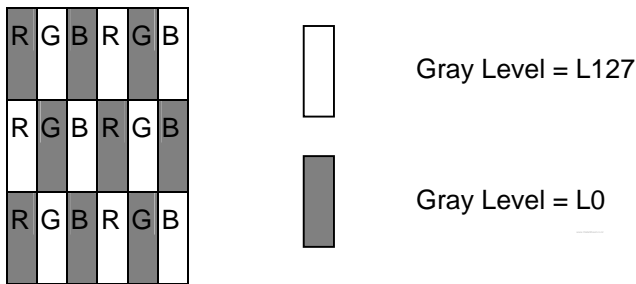

Method : Record dBV & DC value with (WESTAR)TRD-100

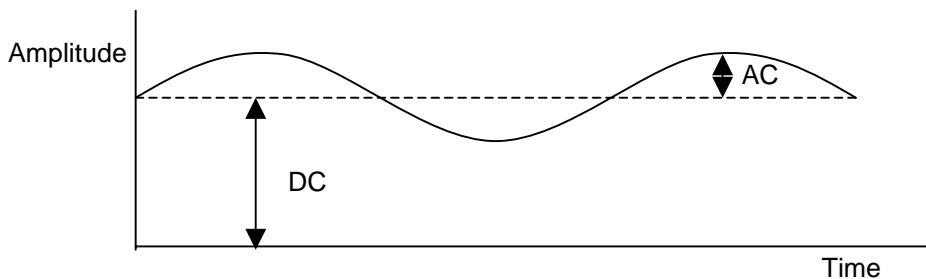

$$\text{Flicker (dB)} = 20 \log \frac{\text{AC Level (at 30 Hz)}}{\text{DC Level}}$$

Note5: Tuning the brightness and contrast function in OSD let the luminance to 125 cd/m². When tuning the brightness to 125cd/m², the function on OSD should not restrict our V-T curve. In other word, the higher contrast, the range of panel's V-T curve will be more extensive to get the better performance. If it is not possible to achieve the test luminance by this procedure it is suitable to tune contrast higher and brightness lower.

2.4 Pixel format image

Following figure shows the relationship of the input signals and LCD pixel format.

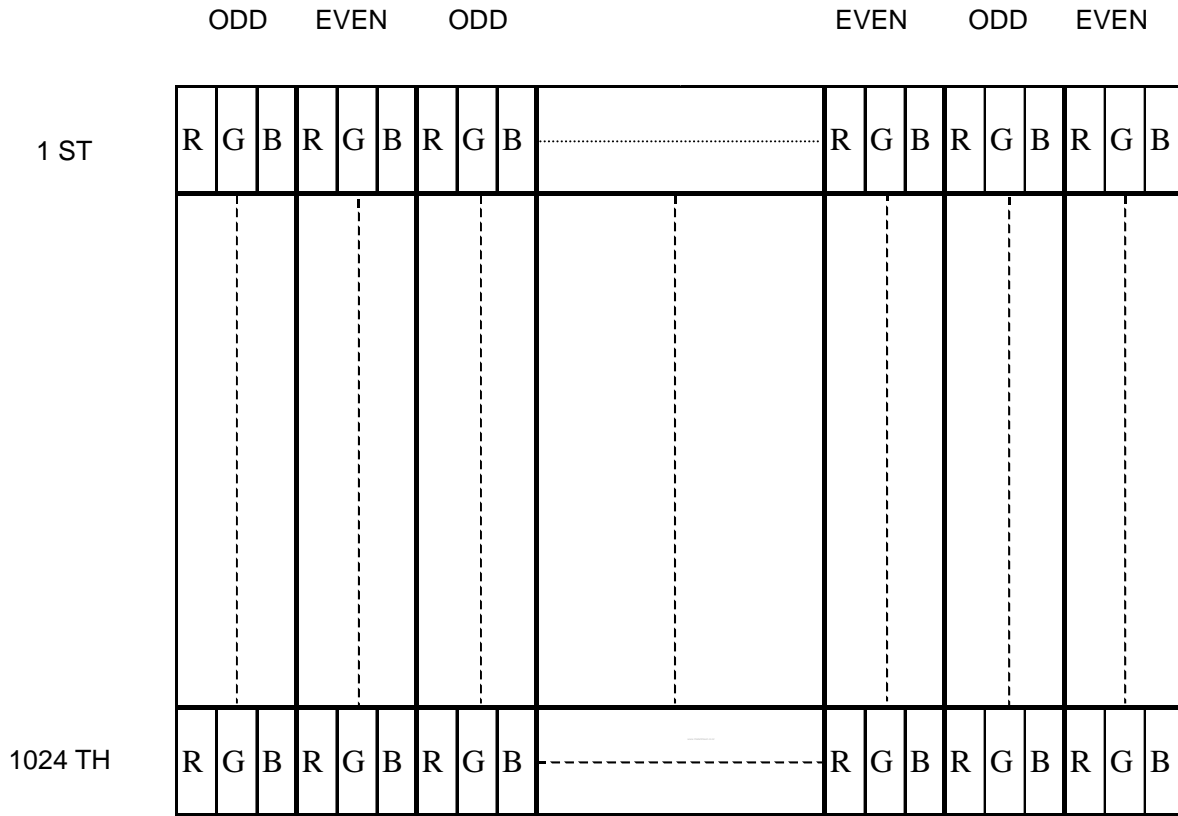

3.0 Electrical characteristics

3.1 Absolute Maximum Ratings

Absolute maximum ratings of the module is as following:

Item	Symbol	Min	Max	Unit	Conditions
Logic/LCD Drive Voltage	VIN	-0.3	6	[Volt]	
CCFL Current	ICFL	-	8.5	[mA] rms	
Operating Temperature	TOP	0	+50	[°C]	Note
Operating Humidity	HOP	8	95	[%RH]	Note
Storage Temperature	TST	-20	+60	[°C]	Note
Storage Humidity	HST	8	95	[%RH]	Note

Note : Maximum Wet-Bulb should be 39 and No condensation.

Relative Humidity %

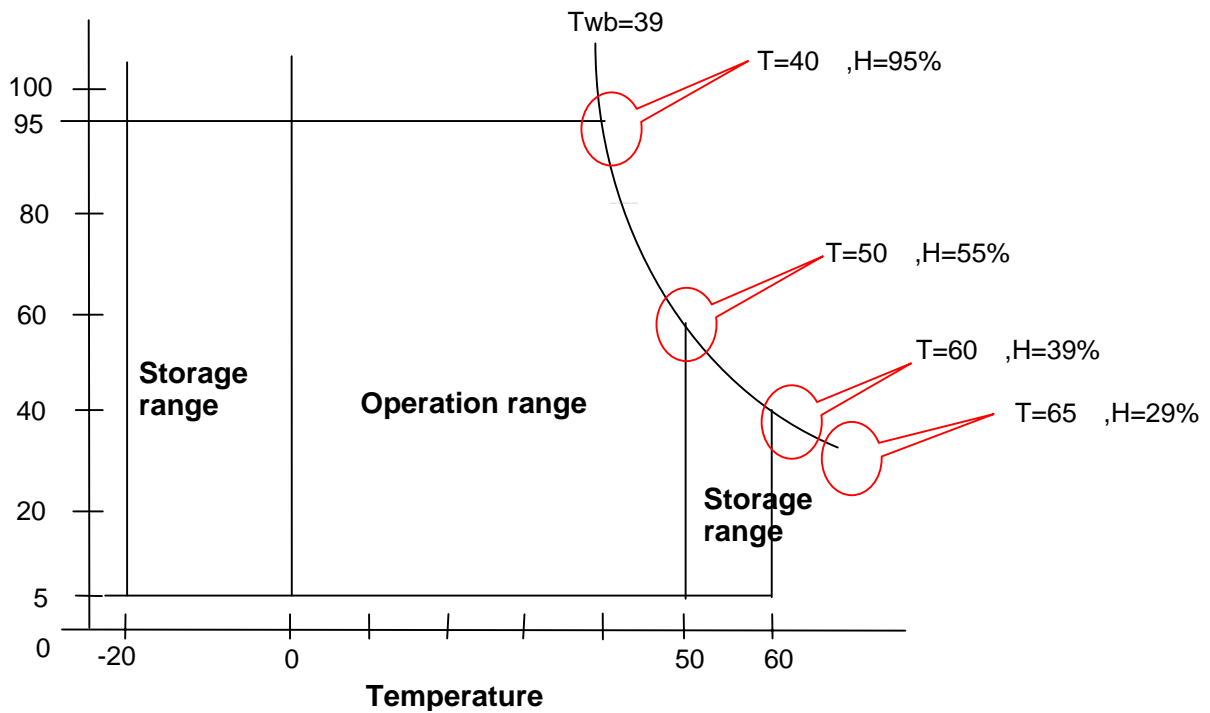

3.2 Connectors

Physical interface is described as for the connector on module.

These connectors are capable of accommodating the following signals and will be following components.

Connector Name / Designation	Interface Connector / Interface card
Manufacturer	JAE or compatible
Type Part Number	FI-XB30SRL-HF11 / MDF76LBRW-30S-1H
Mating Housing Part Number	JAE FI-X30C2L / HRS MDF76G-30P-1SD

Connector Name / Designation	Lamp Connector / Backlight lamp
Manufacturer	JST
Type Part Number	BHSR-02VS-1
Mating Type Part Number	SM02B-BHSS-1-TB

3.3 Signal Pin

Pin#	Signal Name	Pin#	Signal Name
1	RxOIN0-	2	RxOIN0+
3	RxOIN1-	4	RxOIN1+
5	RxOIN2-	6	RxOIN2+
7	VSS	8	RxOCLKIN-
9	RxOCLKIN+	10	RxOIN3-
11	RxOIN3+	12	RxEIN0-
13	RxEIN0+	14	VSS
15	RxEIN1-	16	RxEIN1+
17	VSS	18	RxEIN2-
19	RxEIN2+	20	RxECLKIN-
21	RxECLKIN+	22	RxEIN3-
23	RxEIN3+	24	VSS
25	VSS	26	NC
27	VSS	28	VCC
29	VCC	30	VCC

3.4 Signal Description

The module using a pair of LVDS receiver SN75LVDS82(Texas Instruments) or compatible. LVDS is a differential signal technology for LCD interface and high speed data transfer device. Transmitter shall be SN75LVDS83(negative edge sampling) or compatible. The first LVDS port(RxOxxx) transmits odd pixels while the second LVDS port(RxExxx) transmits even pixels.

PIN #	SIGNAL NAME	DESCRIPTION
1	RxOIN0-	Negative LVDS differential data input (Odd data)
2	RxOIN0+	Positive LVDS differential data input (Odd data)
3	RxOIN1-	Negative LVDS differential data input (Odd data)
4	RxOIN1+	Positive LVDS differential data input (Odd data)
5	RxOIN2-	Negative LVDS differential data input (Odd data,H-Sync,V-Sync,DSPTMG)
6	RxOIN2+	Positive LVDS differential data input (Odd data, H-Sync,V-Sync,DSPTMG)
7	VSS	Power Ground
8	RxOCLKIN-	Negative LVDS differential clock input (Odd clock)
9	RxOCLKIN+	Positive LVDS differential clock input (Odd clock)
10	RxOIN3-	Negative LVDS differential data input (Odd data)
11	RxOIN3+	Positive LVDS differential data input (Odd data)
12	RxEIN0-	Negative LVDS differential data input (Even data)
13	RxEIN0+	Positive LVDS differential data input (Even data)
14	VSS	Power Ground
15	RxEIN1-	Positive LVDS differential data input (Even data)
16	RxEIN1+	Negative LVDS differential data input (Even data)
17	VSS	Power Ground
18	RxEIN2-	Negative LVDS differential data input (Even data)
19	RxEIN2+	Positive LVDS differential data input (Even data)
20	RxECLKIN-	Negative LVDS differential clock input (Even clock)
21	RxECLKIN+	Positive LVDS differential clock input (Even clock)
22	RxEIN3-	Negative LVDS differential data input (Even data)
23	RxEIN3+	Positive LVDS differential data input (Even data)
24	VSS	Power Ground
25	VSS	Power Ground
26	NC	No Connection (for AUO test)
27	VSS	Power Ground
28	VCC	+5.0V Power Supply
29	VCC	+5.0V Power Supply
30	VCC	+5.0V Power Supply

Note1: Start from left side

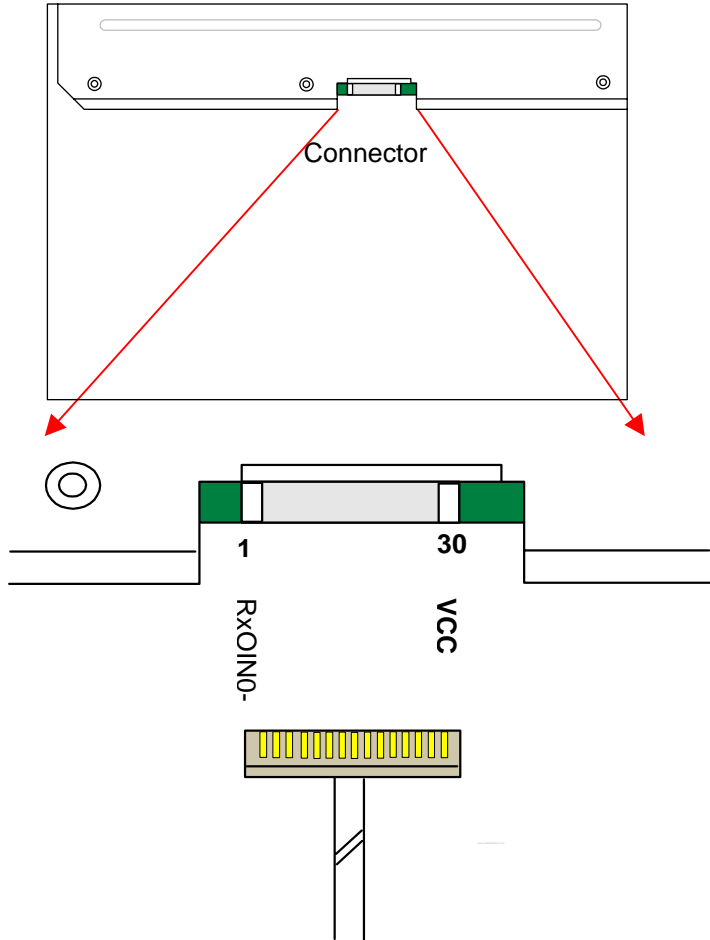

Note2: Input signals of odd and even clock shall be the same timing.

Note3: Please follow PSWG.

The input data format:

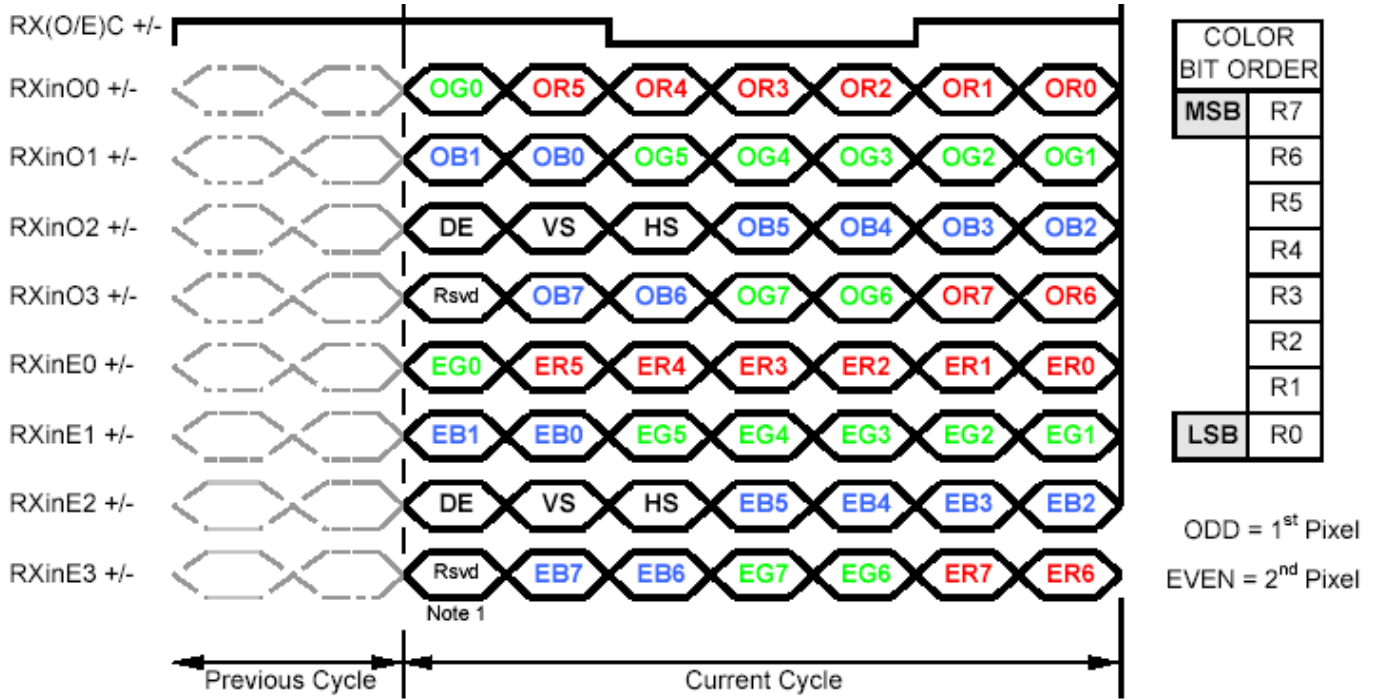

Note1: Normally, DE, VS, HS on EVEN channel are not used.
Note2: Please follow PSWG.

3.5 Signal Electrical Characteristics

Each signal characteristics are as follows;

Symbol	Parameter	Min	Typ	Max	Units	Condition	
VTH	Differential Input High Threshold	-	-	100	[mV]	VICM = 1.2V	<i>Note</i>
VTL	Differential Input Low Threshold	-100	-	-	[mV]	VICM = 1.2V	<i>Note</i>
VID	Input Differential Voltage	100	400	600	[mV]		<i>Note</i>
VICM	Differential Input Common Mode Voltage	1.1	-	1.45	[V]	VTH/VTL = ± 100Mv	<i>Note</i>

Note

LVDS Signal Waveform

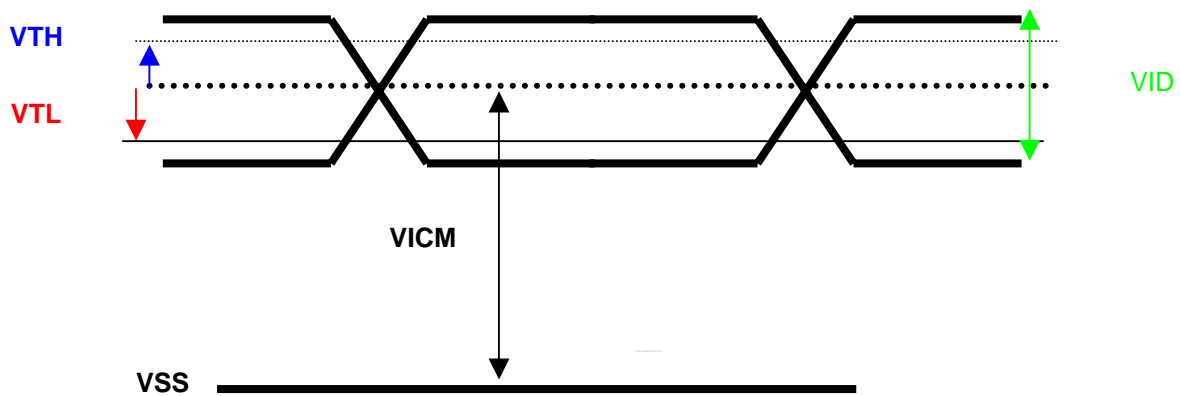

3.6 Interface Timings

3.6.1 Timing Characteristics

Item	Symbol	Min	Typ	Max	Unit
Data CLK	Tclk	45	54	70	MHz
H-section	Period	Th	685	844	Tclk
	Display Area	Tdisp(h)	640	640	Tclk
V-section	Period	Tv	1036	1066	Th
	Display Area	Tdisp(v)	1024	1024	Th
Frame Rate	F	50	60	75	Hz

Note: DE mode only

3.6.2 Timing Definition

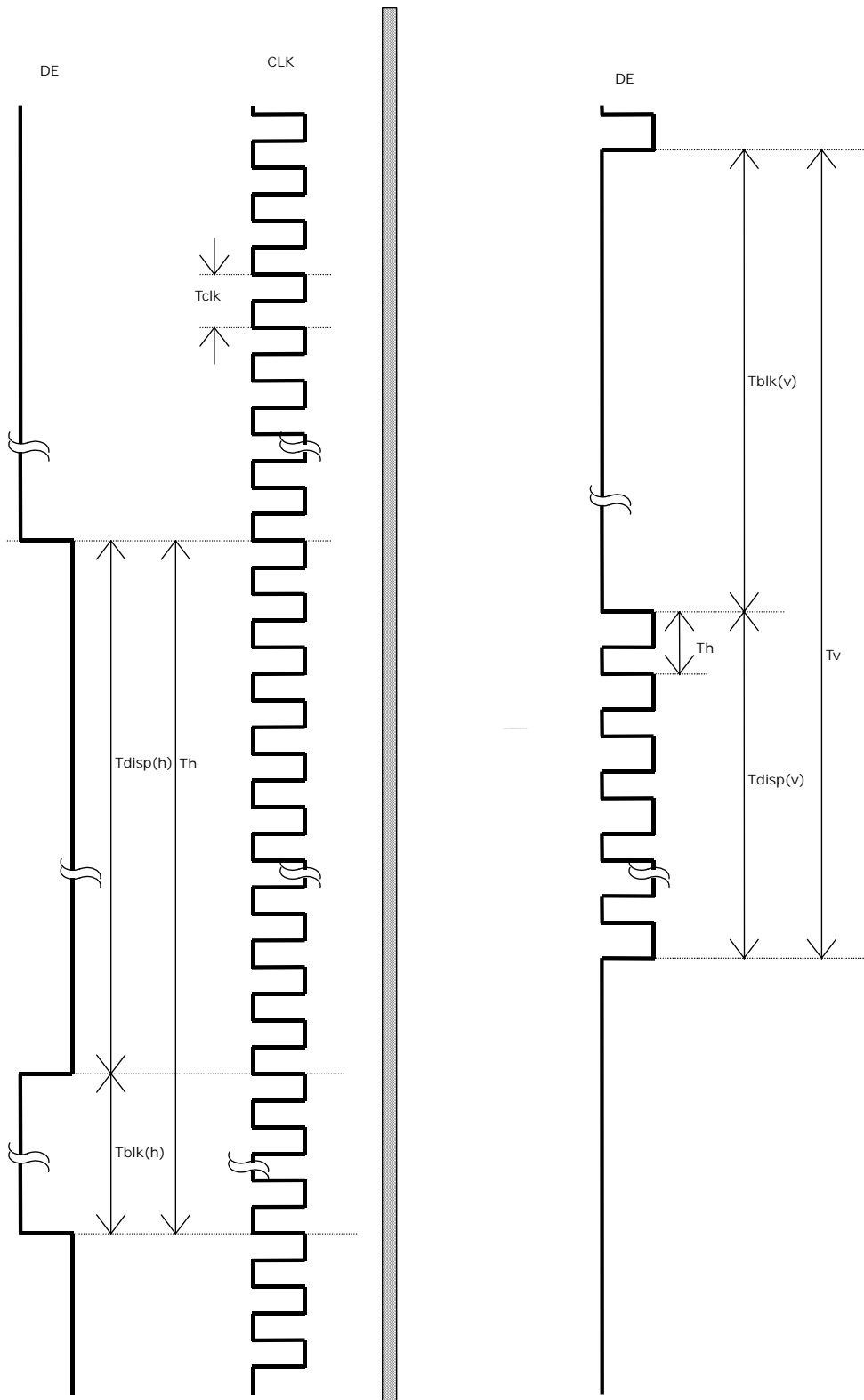

3.7 Power Consumption

Input power specifications are as follows;

Symbol	Parameter	Min	Typ	Max	Units	Condition
VDD	Logic/LCD Drive Voltage	4.5	5	5.5	[Volt]	±10%
IDD	VDD current	-	1200	1560	[mA]	V _{in} =5V , All Black Pattern, +30%, at 75Hz
I _{rush}	LCD Inrush Current	-	-	2.5	[A]	Note
PDD	VDD Power		6	7.8	[Watt]	V _{in} =5V , All Black Pattern, +30%, at 75Hz
VDD _{rp}	Allowable Logic/LCD Drive Ripple Voltage			100	[mV] p-p	

Note: Measurement conditions:

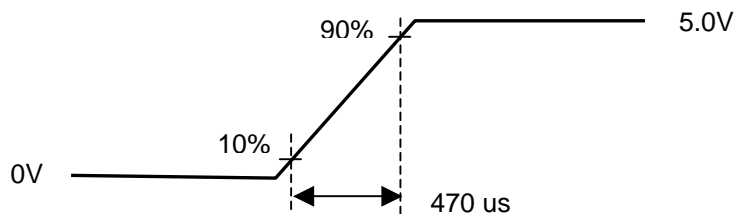
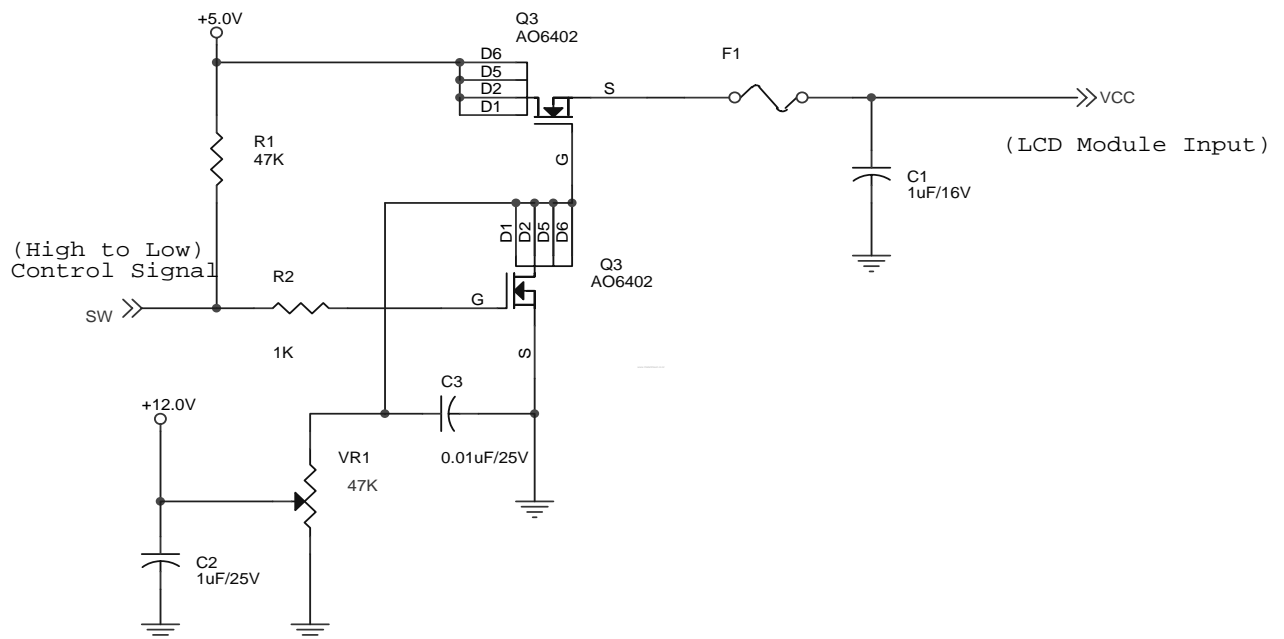

V_{in} rising time

3.8 Power ON/OFF Sequence

Vin and lamp power on/off sequence are as follows. The timing parameters of interface signal are shown in the table below. The signal please reference “3.4 Signal Description”.

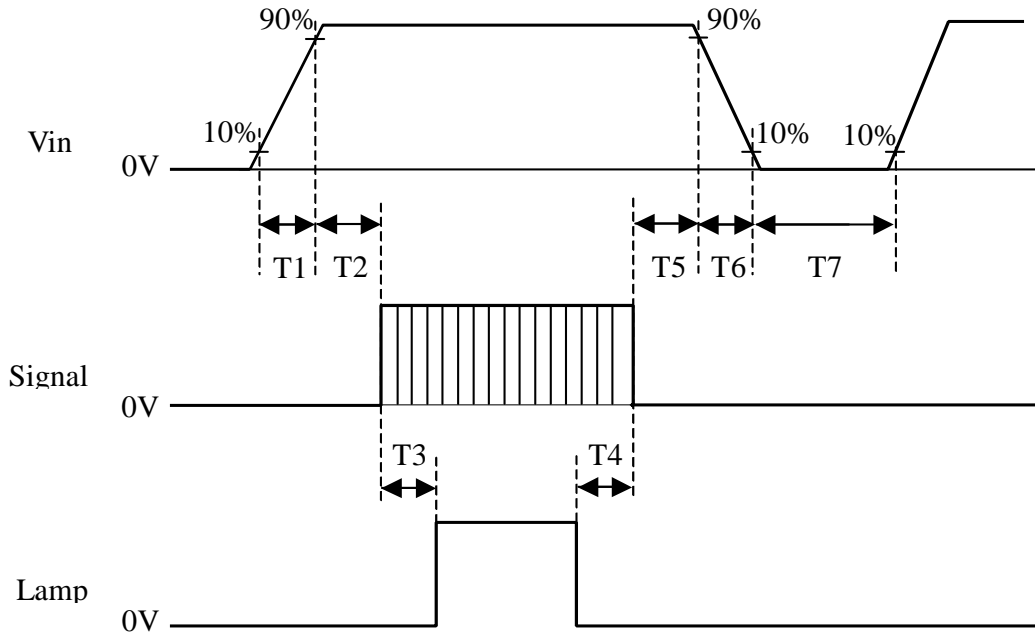

Symbol	Values			Unit
	Min.	Typ.	Max.	
T1	0.5	-	10	ms
T2	0	-	10	ms
T3	200	-	-	ms
T4	100	-	-	ms
T5	0	16	50	ms
T6	-	-	10	ms
T7	1000	-	-	ms

Note: The values of the table are follow PSWG.

4.0 Backlight Characteristics

4.1 Signal for Lamp connector

	Pin No.	Input	Color	Function
Upper	1	Hot1	Pink	High Voltage
	2	Cold1	White	Low Voltage
	3	Hot2	Blue	High Voltage
	4	Cold2	Black	Low Voltage
Lower	1	Hot1	Pink	High Voltage
	2	Cold1	White	Low Voltage
	3	Hot2	Blue	High Voltage
	4	Cold2	Black	Low Voltage

4.2 Parameter guideline for CCFL Inverter

Symbol	Parameter	Min.	Typ.	Max.	Unit	Condition
ISCFL	CCFL standard current	7.0	7.5	8.0	[mA] rms	(Ta=25°C) Note 1
IRCFL	CCFL operation range	3.0	7.5	8.0	[mA] rms	(Ta=25°C)
FCFL	CCFL Frequency	40	60	80	[KHz]	(Ta=25°C) Note 2
ViCFL (0°C)	CCFL Ignition Voltage <i>(End of the lamp wire connector)</i>	1500	-	-	[Volt] rms	(Ta=0°C)
ViCF (25°C)	CCFL Ignition Voltage <i>(End of the lamp wire connector)</i>	1150	-	-	[Volt] rms	(Ta=25°C)
VCFL	CCFL Operation Voltage	-	660 @7.5mA	700 @3.0mA	[Volt] rms	(Ta=25°C) Note 1
PCFL	CCFL Power consumption (for reference)	-	19.8	21.8	[Watt]	(Ta=25°C) Note 3
LTCFL	CCFL life Time	45,000	50,000	-	[Hour]	(Ta=25°C) Note 4

Note 1: CCFL standard current is measured at 25±2 .

Note 2: CCFL Frequency should be carefully determined to avoid interference between inverter and TFT LCD

Note 3: The variance of CCFL power consumption is ±10%. Calculator value for reference

$$(ICFL \times VCFL \times 4 = PCFL).$$

Note 4: CCFL life time is determined as the time at which brightness of lamp is 50%. The typical life time of CCFL is on the condition at 7.0mA lamp current. **The minimum lifetime of CCFL is on the condition at 7.5mA lamp current.**

5.0 Vibration, Shock, and Drop

5.1 Vibration & Shock

Vibration Test Spec:

- Frequency: 10 - 200Hz
- Sweep: 30 Minutes each Axis (X, Y, Z)
- Acceleration: 1.5G(10~200Hz P- P)
- Test method:

Acceleration (G)	1.5
Frequency (Hz)	10~200~10
Active time (min)	30

Shock Test Spec:

Acceleration (G) -a	50
Active time -b	20 ms
Wave form	Half-sin
Times	1

- Direction: $\pm X$, $\pm Y$, $\pm Z$

5.2 Drop test

Package test: The drop height is 60cm.

6.0 Environment

The display module will meet the provision of this specification during operating condition or after storage or shipment condition specified below. Operation at 10% beyond the specified range will not cause physical damage to the unit.

6.1 Temperature and Humidity

6.1.1 Operating Conditions

The display module operates error free, when operated under the following conditions;

Temperature	0 °C to 50 °C
Relative Humidity	8% to 95%
Wet Bulb Temperature	39.0 °C

6.1.2 Shipping Conditions

The display module operates error free, after the following conditions;

Temperature	-20 °C to 60 °C
Relative Humidity	5% to 100%
Wet Bulb Temperature	39.0 °C

6.2 Atmospheric Pressure

The display assembly is capable of being operated without affecting its operations over the pressure range as following specified;

	Pressure	Note
Maximum Pressure	1040hPa	(sea level)
Minimum Pressure	674hPa	(3048m)

6.3 Thermal Shock

The display module will not sustain damage after being subjected to 100 cycles of rapid temperature change. A cycle of rapid temperature change consists of varying the temperature from -20°C to 60°C, and back again.

Thermal shock cycle -20 °C for 30min
 60 °C for 30min

Power is not applied during the test. After temperature cycling, the unit is placed in normal room ambient for at least 4 hours before powering on.

7.0 Reliability

This display module and the packaging of that will comply following standards.

7.1 Failure Criteria

The display assembly will be considered as failing unit when it no longer meets any of the requirements stated in this specification. Only as for maximum white luminance, following criteria is applicable.

- **Maximum white Luminance shall be 150cd/m² or more.**

7.2 Failure Rate

The average failure rate of the display module (from first power-on cycle till 1,000 hours later) will not exceed 1.0%. The average failure rate of the display module from 1,000 hours until 16,000 hours will not exceed 0.7% per 1000 hours.

7.2.1 Usage

The assumed usage for the above criteria is:

- 220 power-on hours per month
- 500 power on/off cycles per month
- Maximum brightness setting
- Operation to be within office environment (25°C typical)

8.0 Safety

8.1 Sharp Edge Requirements

There will be no sharp edges or comers on the display assembly that could cause injury.

8.2 Materials

8.2.1 Toxicity

There will be no carcinogenic materials used anywhere in the display module. If toxic materials are used, they will be reviewed and approved by the responsible ADT Toxicologist.

8.2.2 Flammability

All components including electrical components that do not meet the flammability grade UL94-V1 in the module will complete the flammability rating exception approval process.

The printed circuit board will be made from material rated 94-V1 or better. The actual UL flammability rating will be printed on the printed circuit board.

8.3 Capacitors

If any polarized capacitors are used in the display assembly, provisions will be made to keep them from being inserted backwards.

9.0 Other requirement

9.1 National Test Lab Requirement

The display module will satisfy all requirements for compliance to

UL 1950, First Edition
CSA C22.2 No.950-M89
EEC 950
EN 60 950

U.S.A. Information Technology Equipment
 Canada, Information Technology Equipment
 International, Information Technology Equipment
 International, Information Processing Equipment
 (European Norm for IEC950)

9.2 Label

The label is on the panel as shown below:

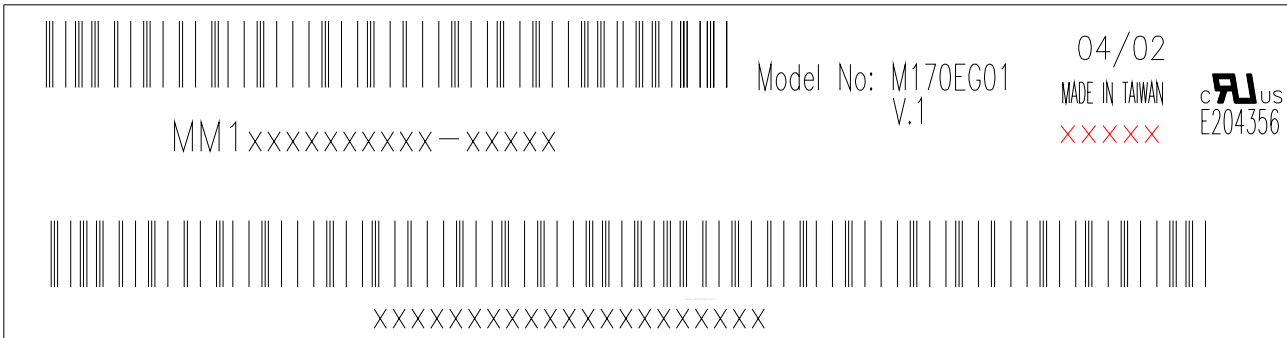

10.0 Mechanical Characteristics

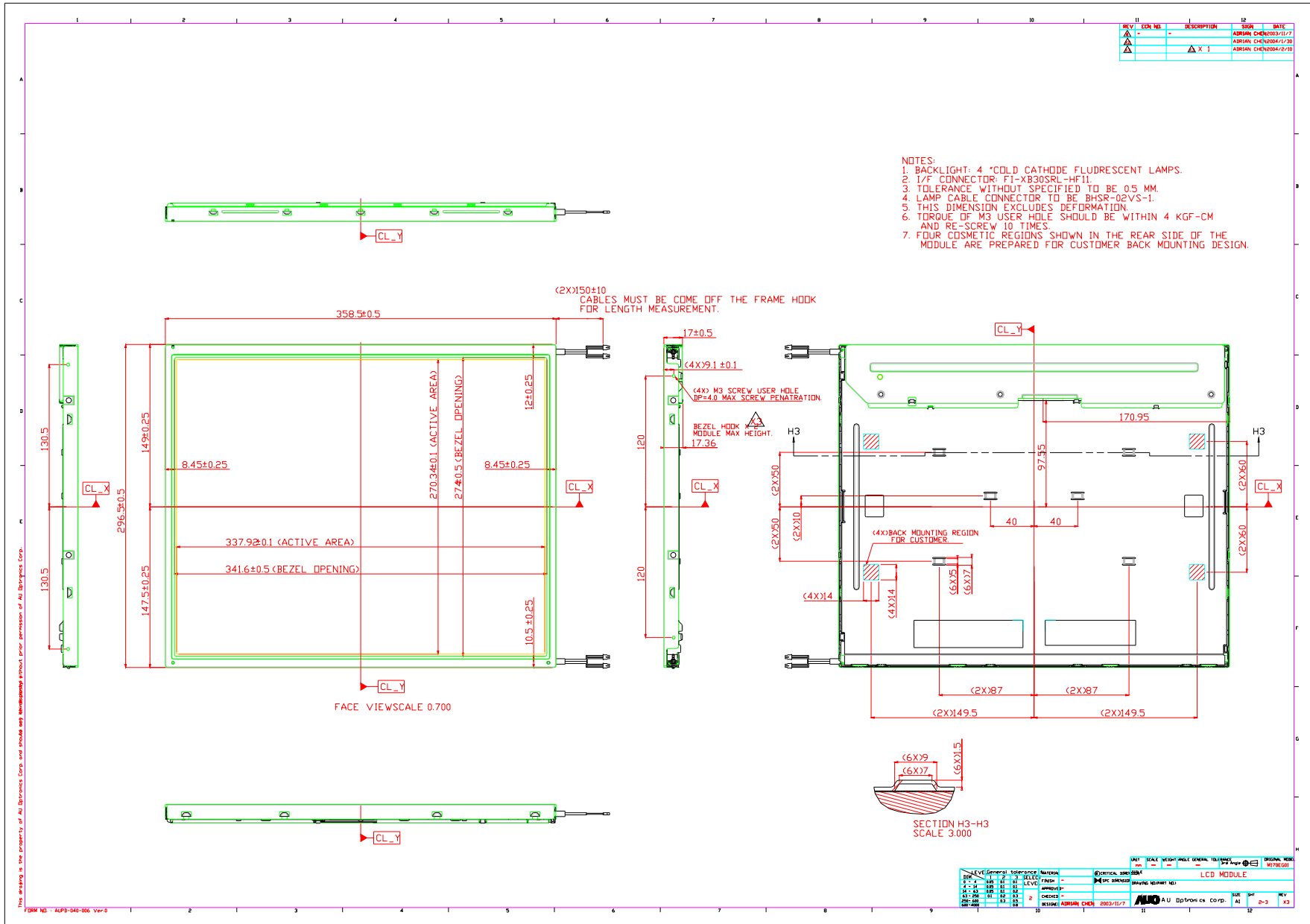

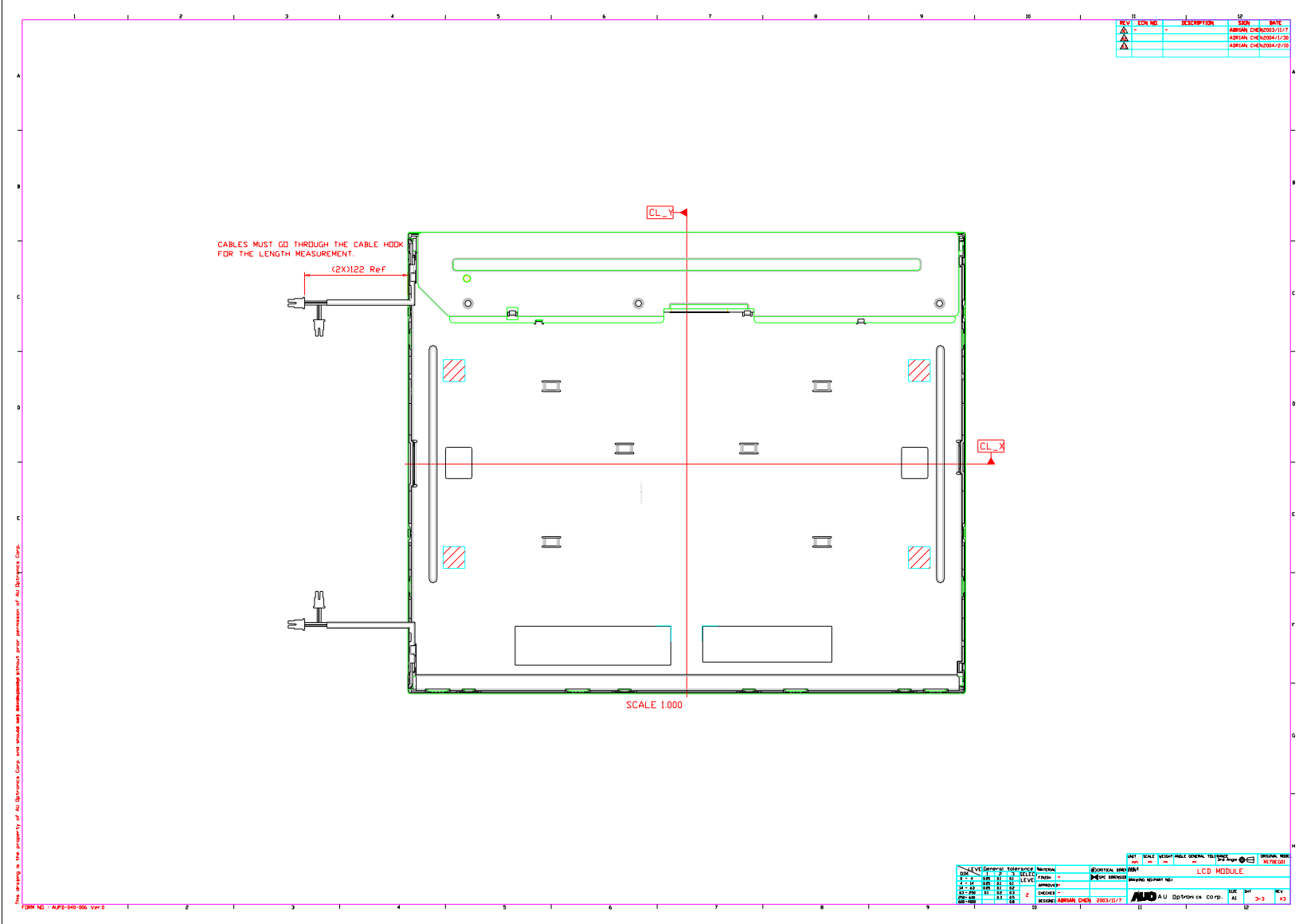

REV	LOG NO.	DESCRIPTION	DATE	BY
-	-	-	-	-
△	-	-	2003/11/27	ASHIAN CHEN
△	-	-	2004/1/20	ASHIAN CHEN
△	-	-	2004/2/10	ASHIAN CHEN

This drawing is the property of AU Optronics Corp. and should not be reproduced without prior permission of AU Optronics Corp.

FORM NET: AUPP-040-006 Ver.0

REV	DATE	DESCRIPTION	BY	CHK
01	2003/11/27	ISSUE	ASHIAN CHEN	
02	2004/1/20	REVISED	ASHIAN CHEN	
03	2004/2/10	REVISED	ASHIAN CHEN	

PROJECT	SCALE	WEIGHT	DATE	GENERAL	TITLE	PROJECT NO.	REVISION NO.
FORM NET	1:1000		2003/11/27		LCD MODULE		