



AU OPTRONICS CORPORATION

Product Specification

17.0" SXGA Color TFT-LCD Module

Model Name: M170EP01 V.2

Approved by	Prepared by
<i>CC Chiou</i>	<i>Roger Yang</i>

DDBU Marketing Division / AU Optronics corporation

Customer	Checked & Approved by



Page intentionally left blank.

www.panelook.com



M170EP01 V.2

Product Specification

Product Specification

17.0" SXGA Color TFT-LCD Module Model Name: M170EP01 V.2

(◆) Preliminary Specifications
(...) Final Specifications

Note: This Specification is subject to change without notice.



Product Specification

M170EP01 V.2

Page intentionally left blank.

www.panelook.com



Contents

2.0 General Description	13
2.1 Display Characteristics.....	13
2.2 Functional Block Diagram	14
2.3 Optical Characteristics	15
2.4 Pixel format image.....	17
3.0 Electrical characteristics	18
3.1 Absolute Maximum Ratings	18
3.2 Connectors	19
3.3 Pin Assignment	20
3.4 Signal Description	21
3.5 Signal Electrical Characteristics	24
3.6 Interface Timings	24
3.6.1 Timing Characteristics	24
3.6.2 Definition of terms	25
3.8 Power ON/OFF Sequence	27
4.0 Backlight Characteristics	29
4.1 Signal for Lamp connector	29
4.2 Parameter guideline for CCFL Inverter.....	29
5.0 Vibration, Shock, and Drop	31
5.1 Vibration & Shock.....	31
5.2 Drop test	31
6.0 Environment	32
6.1 Temperature and Humidity.....	32
6.1.1 Operating Conditions.....	32
6.1.2 Shipping Conditions	32
6.2 Atmospheric Pressure	32
6.3 Thermal Shock.....	32
7.0 Reliability.....	33
7.1 Failure Criteria	33
7.2 Failure Rate.....	33
7.2.1 Usage.....	33
8.0 Safety	34
8.1 Sharp Edge Requirements	34
8.2 Materials	34
8.2.1 Toxicity	34
8.2.2 Flammability	34
8.3 Capacitors	34
9.0 Other requirement	35



Product Specification

M170EP01 V.2

9.1 National Test Lab Requirement 35

9.2 Label 35

10.0 Mechanical Characteristics..... 36

www.panelook.com



Record of Revision

Version and Date	Page	Old description	New Description	Remark
0.1 4/26/2005	All	First Edition for Customer	All	



Product Specification

M170EP01 V.2

Page intentionally left blank.

www.panelook.com



1.0 Handling Precautions

- 1) Do not scratch the front polarizer of panel. The front polarizer is easily damaged
- 2) Be sure to turn off power supply when inserting and disconnecting from input connector.
- 3) Wipe off water drop immediately. Contacted with water in a long time may cause discoloration or spots.
- 4) Use absorbent cotton or other kind of soft cloth to wipe when the panel is dusty.
- 5) Do not drop it on hard surface. The face of panel is fragile
- 6) Since CMOS LSI is used in this module, take care of static electricity and insure human earth when handling.
- 7) Do not open nor modify the Module Assembly.
- 8) Do not press the reflector sheet at the back of the module to any directions.
- 9) The TFT module will be damaged if the center of the CCFL reflector is pressed heavily.
- 10) Keep the connector interface straight during the period of inserting and disconnecting it.
- 11) Do not twist nor bend the TFT Module even momentary. At designing the enclosure, it should be taken into consideration that no bending/twisting forces are applied to the TFT module from outside. Otherwise the TFT module may be damaged.



M170EP01 V.2

Product Specification

2.0 General Description

This specification applies to the 17.0 inch Color TFT/LCD Module M170EP01 V0.

This module is designed for a display unit of personal computer.

The display supports the SXGA (1280(H) x 1024(V)) screen format and 16.2M colors (RGB 6-bits + FRC data).

The input signal is Analog RGB interface compatible, DVI interface optional.

This module does not contain an inverter card for backlight.

2.1 Display Characteristics

The following items are characteristics summary on the table under 25 °C condition:

ITEMS	Unit	SPECIFICATIONS			
Screen Diagonal	[mm]	432(17.0")			
Active Area	[mm]	337.920 (H) x 270.336(V)			
Pixels H x V		1280(x3) x 1024			
Pixel Pitch	[mm]	0.264 (per one triad) x 0.264			
Pixel Arrangement		R.G.B. Vertical Stripe			
Display Mode		Normally White			
White Luminance	[cd/m ²]	300 (Typ) ¹			
Contrast Ratio		500:1(Typ) ²			
Optical Rise Time/Fall Time	[msec]	8 (Typ)			
Input Voltage Required (VDD)	[Volt]	Min	Typical	Max	
		4.8	5.0	5.2	
Power Consumption (VDD line + CCFL line)	[Watt]	27 W(Typ) 0.5W (stand by) (PDD=7 W, PCFL=20 W @Lamp=7.5mA)			
Weight	[Grams]	2000 (Typ)			
Physical Size	[mm]		Min.	Typ.	Max.
		Horazatal(H)	358	358.5	359.0
		Vertical(V)	296	296.5	297
		Depth(D)	19.5	20	20.5
Electrical Interface		VESA standard Analog RGB (DVI 1.0 optional)			
Support Color		16.2M colors (RGB 6-bit + FRC data)			
Plug & Play		VESA DDC1/2B/2Bi/2B+/CI ³			
Compability		PC/MAC			
Maximum Firmware Code Size	[bite]	64K			
Max. Pixel Clock	[MHz]	Analog: 140MHz			
		Digital: 135MHz (optional)			
White Point (CIE x,y)		(0.313,0.329) +/-0.02			
Auto Adjustment		Yes ³			
OSD function					
Temperature Range	[°C]	0 to +50			
	[°C]	-20 to +60			
TC0-03 Compliance		TC0'03 Compliance ⁴			

¹ at 7.5 mA

² normal direction

³ with AUO standard firmware

⁴ AUO standard power module & firmware



M170EP01 V.2

Product Specification

2.2 Functional Block Diagram

The following diagram shows the functional block of the 17.0 inches Color TFT/LCD Module:

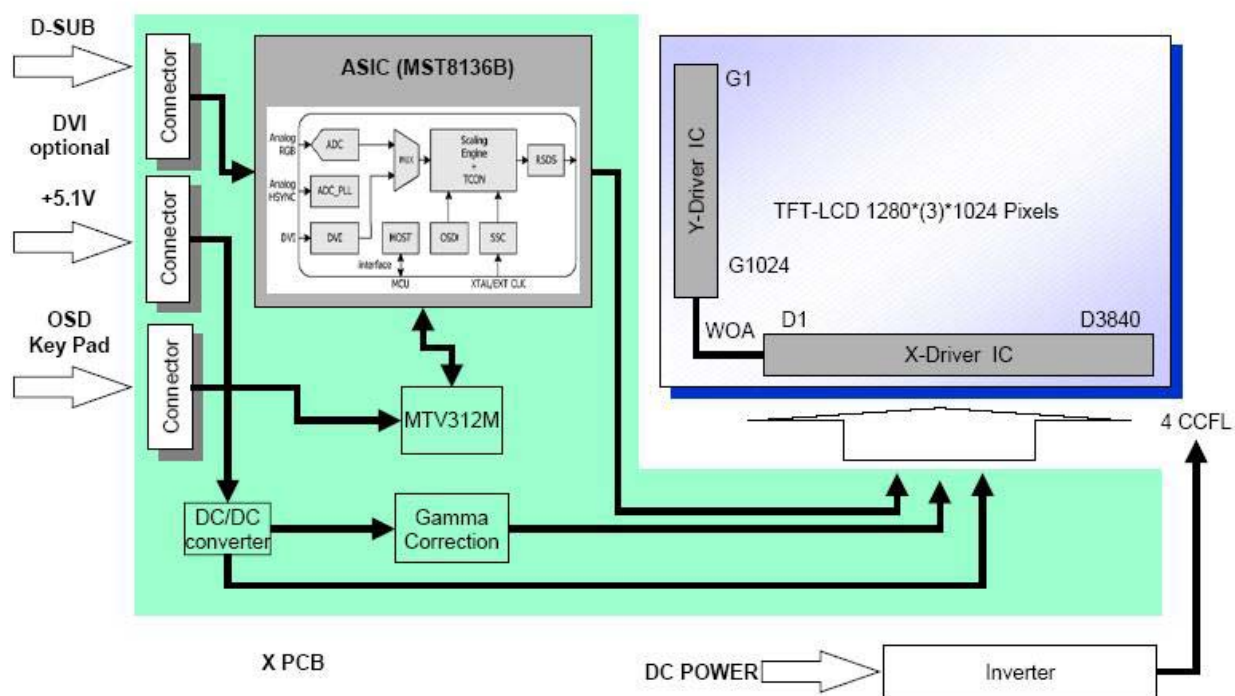



M170EP01 V.2

Product Specification

2.3 Optical Characteristics

The optical characteristics are measured under stable conditions at 25°C (Room Temperature):

Item	Unit	Conditions	Min.	Typ.	Max.	Note
Viewing Angle	[degree]	Horizontal (Right) CR = 10 (Left)	60 60	70 70		-
		Vertical (Up) CR = 10 (Down)	60 50	70 60		-
Contrast ratio		Normal Direction	250	450		-
Response Time	[msec]	Raising Time	-	6	9	Note 1
		Falling Time	-	2	4	
		Raising + Falling	-	8	13	
Color / Chromaticity Coordinates (CIE)		Red x	0.61	0.64	0.67	
		Red y	0.31	0.34	0.37	
		Green x	0.26	0.29	0.32	
		Green y	0.58	0.61	0.64	
		Blue x	0.11	0.14	0.17	
		Blue y	0.04	0.07	0.10	
Color Coordinates (CIE) White		White x	0.28	0.31	0.34	
		White y	0.30	0.33	0.36	
White Luminance @ CCFL 7.5mA (center)	[cd/m ²]		250	300		Note 2
Luminance Uniformity	[%]		75	80		Note 3
Crosstalk (in 75Hz)	[%]				1.5	Note 4
Flicker	dB				-20	

Equipment: Pattern Generator, Power Supply, Digital Voltmeter, Luminance meter
(PR 880, BM-5A / BM7)

Aperture 1° with 100cm VD or 2° with 50cm viewing distance

Test Point Center (VESA point 9)

Environment < 1 lux

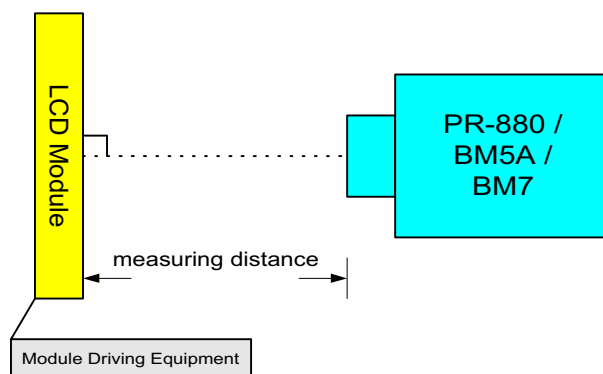

Ver0.1

15/26

Note 1: Definition of Response time

The output signals of photodetector are measured when the input signals are changed from "Black" to "White" (rising time), and from "White" to "Black" (falling time), respectively. The response time is interval between the 10% and 90% of amplitudes.

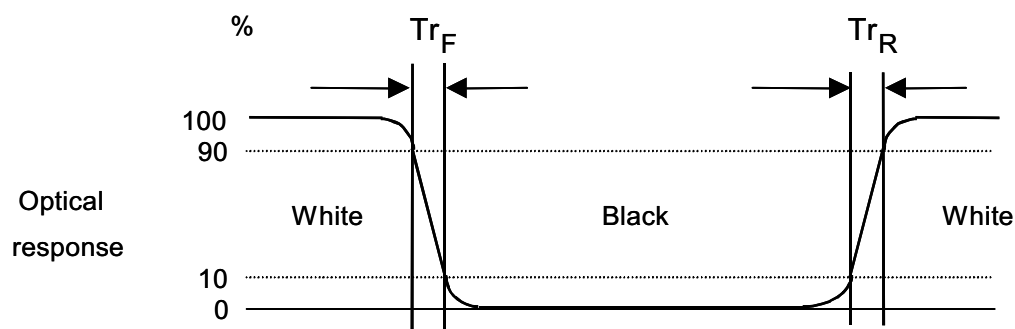
**Note 2: Definition of center brightness**

The brightness of center is measured at 30mins when opening lamp.

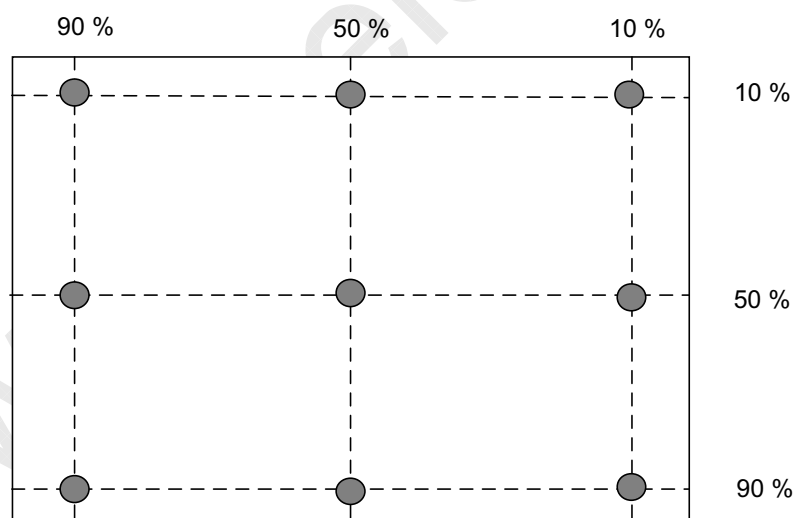
Note 3: Brightness uniformity of these 9 points is defined as below

$$\text{Uniformity} = \frac{\text{Minimum Luminance in 9 points (1-9)}}{\text{Maximum Luminance in 9 Points (1-9)}}$$



Product Specification

M170EP01 V.2

Note 4:

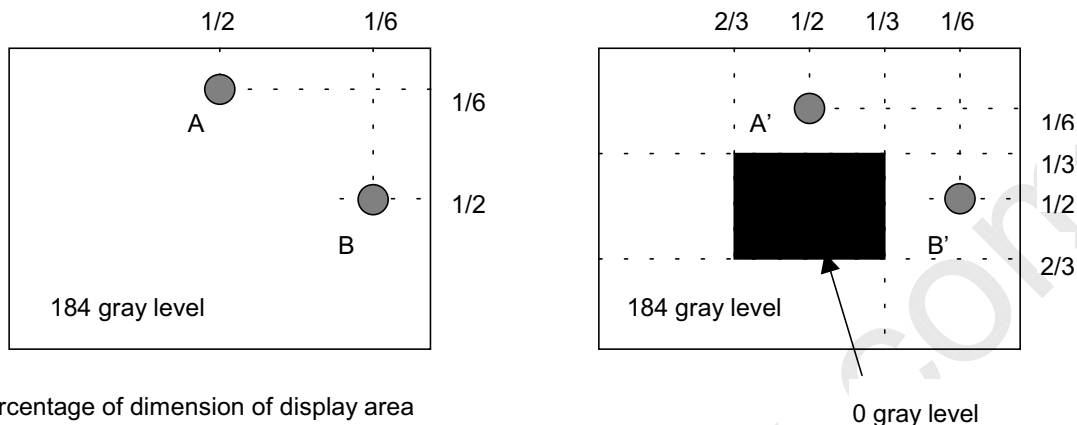

Unit: percentage of dimension of display area

$$|L_A - L_{A'}| / L_A \times 100\% = 1.5\% \text{ max.}, L_A \text{ and } L_B \text{ are brightness at location A and B}$$

$$|L_B - L_{B'}| / L_B \times 100\% = 1.5\% \text{ max.}, L_{A'} \text{ and } L_{B'} \text{ are brightness at location A' and B'}$$

2.4 Pixel format image

Following figure shows the relationship of the input signals and LCD pixel format.

	1		2		...												1279		1280					
1st Line	R	G	B	R	G	B	...												R	G	B	R	G	B
	-	-	-	-	-	-	...												-	-	-	-	-	-

1024th	R	G	B	R	G	B	...												R	G	B	R	G	B



3.0 Electrical characteristics

3.1 Absolute Maximum Ratings

Absolute maximum ratings of the module is as following:

Item	Symbol	Min	Max	Unit	Conditions
Logic/LCD Drive Voltage	VIN	+4.5	+5.5	[Volt]	
CCFL Current	ICFL	-	8.5	[mA] rms	
Operating Temperature	TOP	0	+50	[°C]	Note
Operating Humidity	HOP	8	95	[%RH]	Note
Storage Temperature	TST	-20	+60	[°C]	Note
Storage Humidity	HST	8	95	[%RH]	Note

Note : Maximum Wet-Bulb should be 39°C and No condensation.

Relative Humidity %

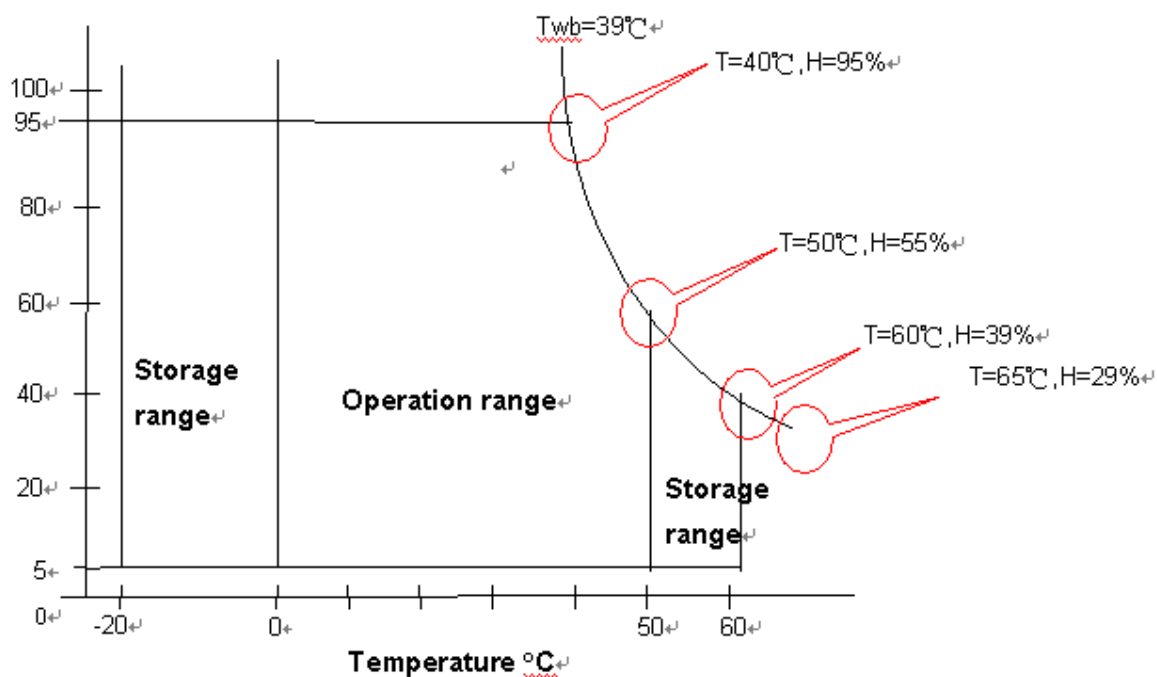



Product Specification

3.2 Connectors

Physical interface is described as for the connector on module.

These connectors are capable of accommodating the following signals and will be following components.

Connector Name / Designation	Power Connector (J1)
Manufacturer	STM or compatible
Type Part Number	STM MS242612R
Mating Housing Part Number	STM P242612

Connector Name / Designation	OSD Connector (J4)
Manufacturer	STM or compatible
Type Part Number	STM MS242613R
Mating Housing Part Number	STM PS242613

Connector Name / Designation	VGA Connector (J2)
Manufacturer	STM or compatible
Type Part Number	STM MS242614R
Mating Housing Part Number	STM P242614R

Connector Name / Designation	DVI Connector (optional)
Manufacturer	STM or compatible
Type Part Number	STM MDS240315
Mating Housing Part Number	STM PDS240315

Connector Name / Designation	Lamp Connector / Backlight lamp
Manufacturer	JST
Type Part Number	BHSR-02VS-1
Mating Type Part Number	SM02(4.0)B-BHS-1-TB



Product Specification

M170EP01 V.2

3.3 Pin Assignment

➤ VGA connector

Pin #	Signal Name	Pin #	Signal Name
1	GND	2	VS
3	HS	4	GNDB
5	BIN	6	GNDG
7	GIN	8	GNDR
9	RIN	10	GND
11	SDA	12	SCL
13	PC5V	14	VGA_CON

➤ Power connector

Pin #	Signal Name	Pin #	Signal Name
1	VCC	2	VCC
3	GND	4	GND
5	NC	6	GND
7	BKLT_ADJ	8	BKLT_EN
9	AUDIO_EN	10	MUTE
11	VOLUME	12	GND

➤ OSD connector

Pin #	Signal Name	Pin #	Signal Name
1	GND	2	SOURCE
3	SELECT	4	LED_G
5	LED_A	6	UP
7	DOWN	8	MINUS
9	PLUS	10	MENU
11	Power	12	NC
13	GND		

➤ DVI connector (optional)

Pin #	Signal Name	Pin #	Signal Name
1	GND	2	GND
3	RX2+	4	DVI_5V
5	RX2-	6	HPD
7	GND	8	GND
9	RX1+	10	SDA
11	RX1-	12	SCL
13	GND	14	GND
15	RX0+	16	NC
17	RX0-	18	NC
19	GND	20	GND
21	RXC+	22	DVI_CON
23	RXC-	24	GND
25	GND	26	NC
27	NC	28	GND
29	GND	30	NC



Product Specification

M170EP01 V.2

3.4 Signal Description

The module using analog RGB signal format (DVI optional). The signal description is listed as following table

➤ VGA connector (J2)

Pin#	Signal Name	Description
1	GND	Ground
2	VS	Vsync input from VGA host
3	HS	Hsync input from VGA host
4	GNDB	Ground for the video blue signal
5	BIN	Video blue signal
6	GNDG	Ground for the video green signal
7	GIN	Video green signal
8	GNDR	Ground for the video red signal
9	RIN	Video red signal
10	GND	Ground
11	SDA	Data signal for the DDC2B
12	SCL	Clock signal for the DDC2B
13	PC5V	DC 5V from the PC host
14	VGA_CON	Video cable connected detect signal(host connect this pin to ground)

➤ Power connector (J1)

Pin#	Signal Name	Description
1	VCC	DC 5V
2	VCC	DC 5V
3	GND	Ground
4	GND	Ground
5	NC	NC
6	GND	Ground
7	BKLT_ADJ	Light adjust for the DC/AC inverter(PWM)
8	BKLT_EN	Enable for the DC/AC inverter
9	AUDIO_EN	Enable audio power control signal
10	MUTE	Mute audio
11	VOLUME	Adjust audio volume(PWM)
12	GND	Ground

➤ OSD connector (J4)

Pin#	Signal Name	Description
1	GND	Ground
2	SOURCE	OSD item source function.
3	SELECT	OSD item select function.
4	LED_G	LED Green for the full mode.
5	LED_A	LED Amber for the sleep mode.
6	UP	OSD up selection function.
7	DOWN	OSD down selection function.
8	MINUS	OSD minus selection function.
9	PLUS	OSD plus selection function.
10	MENU	OSD menu on/off function.
11	Power	Power on/off function.
12	NC	
13	GND	Ground



Product Specification

M170EP01 V.2

➤ DVI interface (J3 optional)

Pin#	Signal Name	Description
1	GND	Ground
2	GND	Ground
3	RX2+	TMDS RX2+ signal
4	DVI_5V	DC 5V from the PC host
5	RX2-	TMDS RX2- signal
6	HPD	Host detect for the DVI
7	GND	Ground
8	GND	Ground
9	RX1+	TMDS RX1+ signal
10	SDA	Data signal for the DDC2B
11	RX1-	TMDS RX1- signal
12	SCL	Clock signal for the DDC2B
13	GND	Ground
14	GND	Ground
15	RX0+	TMDS RX0+ signal
16	NC	
17	RX0-	TMDS RX0- signal
18	NC	
19	GND	Ground
20	GND	Ground
21	RXC+	TMDS RXC+ signal
22	DVI_CON	DVI cable connected detect
23	RXC-	TMDS RXC- signal
24	GND	Ground
25	GND	Ground
26	NC	
27	NC	
28	GND	Ground
29	GND	Ground
30	NC	



M170EP01 V.2

Product Specification

The input data format is followed the VESA Video Signal Standard. In each RGB termination is described as following table

	Value
Max Luminance Voltage Input Data = (FFh)	0.700 Volts +0.070 /-0.035 volts
Min Luminance voltage Input Data = (00h)	0.000 Volts
Video Channel Rise/Fall Time Max	25% of minimum pixel clock period
Maximum Settling Time after overshoot/undershoot	30% of minimum pixel clock period averaged over 100 waveforms to 5% final full-scale value.
Monotonic	Yes
Resolution	1 LSB
Integral Linearity Error	+/- 1 LSB
Differential Linearity Error	+/- 1 LSB
Video Channel to Video Channel Mismatch	6% of any video output voltage over the full voltage range
Video Noise injection ratio	+/- 2.5 % of Max Luminance Voltage
Video Channel to Video Channel Output Skew	50% of minimum pixel clock period
Overshoot/Undershoot	+/-12% of step function voltage level over the full voltage range

The Synchronization (Hsync and Vsync) Signal format is described as following table

	Min	Max
Driver Logic Level "1"	2.4 Volts	5.5 Volts
Driver Logic Level "0"	0.0 Volts	0.5 Vots
Driver High Level Output Current	8mA	
Driver Low Level Output Current	8mA	
Receiver Logic Level "1"	2.0 Volts	
Receiver Logic Level "0"		0.8 Volts
Fall Time Max		80% of minimum pixel clock period
Rise Time Max		80% of minimum pixel clock period
Monotonic Rise/Fall Voltage range	0.5-2.4 Volts	
Overshoot/Undershoot		30% of high level signal voltage range No signal excursions allowed in the 0.5-2.4 volt voltage range
Jitter (Measured between Hsync pulses).		Over the frequency spectrum: One half of the difference between the maximum and minimum interval between Hsync pulses measured over 100,000 intervals shall be less than 15% of the pixel clock, 0Hz to max. horizontal refresh rate at all image formats, worst-case screen patterns.

LSB Least Significant Bit

Monotonic

1. The property of either never increasing or never decreasing in reference to the slope of a Transient response. 2. A constant slope value containing no inflection points.

Sync Synchronization Signals

For more detail, please refer to VESA (**Video Electronics Standards Association**) Video Signal Standard.



Product Specification

M170EP01 V.2

3.5 Signal Electrical Characteristics

➤ VGA interface

Pin	Name	Type	Min.	Typ.	Max.	Unit
1	GND					
2	VS	High	2.5		VCC	V
		Low	GND		0.8	
3	HS	High	2.5		VCC	V
		Low	GND		0.8	
4	GNDB					
5	BIN			700		mV
6	GNDG					
7	GIN			700		mV
8	GNDR					
9	RIN			700		mV
10	GND					
11	SDA	High	3.5		VCC	V
		Low	GND		0.8	V
12	SCL	High	3.5		VCC	V
		Low	GND		0.8	V
13	PC5V					
14	VGA CON					

Please follow Mstar MST8116B SPEC.

➤ OSD interface

Pin	Name	Type	Min.	Typ.	Max.	Unit
1	GND					
2	SOURCE	High	4		VCC	V
		Low	0		0.45	V
3	SELECT	High	4		VCC	V
		Low	0		0.45	V
4	LED_G				VCC	
5	LED_A				VCC	
6	UP	High	4		VCC	V
		Low	0		0.45	V
7	DOWN	High	4		VCC	V
		Low	0		0.45	V
8	MINUS	High	4		VCC	V
		Low	0		0.45	V
9	PLUS	High	4		VCC	V
		Low	0		0.45	V
10	MENU	High	4		VCC	V
		Low	0		0.45	V
11	Power	High	4		VCC	V
		Low	0		0.45	V
12	NC					
13	GND					

3.6 Interface Timings

The signal interface of the TFT module is analog RGB compatible

3.6.1 Timing Characteristics

The timings are supported by the signal interface of M170EP01 are listed as following table.



M170EP01 V.2

Product Specification

Resolution	Horizontal Frequency (KHz)	Vertical Frequency (Hz)	Dot Clock (MHz)	Actually Display Resolution	Remark
640x350	31.47(P)	70.08(N)	25.17	1280x943	DOS
720x400	31.47(N)	70.08(P)	28.32	1280x1024	DOS
640x480	31.47(N)	60.00(N)	25.18	1280x1024	DOS
640x480	35.00(N)	67.00(N)	30.24	1280x1024	Macintosh
640x480	37.86(N)	72.80(N)	31.5	1280x1024	VESA
640x480	37.50(N)	75.00(N)	31.5	1280x1024	VESA
800x600	37.88(P)	60.32(P)	40	1280x1024	VESA
800x600	48.08(P)	72.19(P)	50	1280x1024	VESA
800x600	46.86(P)	75.00(P)	49.5	1280x1024	VESA
832X624	49.72(N)	74.55(N)	57.29	1280x1024	Macintosh
1024x768	48.36(N)	60.00(N)	65	1280x1024	VESA
1024x768	56.48(N)	70.10(N)	75	1280x1024	VESA
1024x768	60.02(P)	75.00(P)	78.75	1280x1024	VESA
1024X768	60.24(N)	74.93(N)	80	1280x1024	Macintosh
1152x864	67.50(P)	75.00(P)	108	1280x1024	VESA
1152x870	68.68(N)	75.06(N)	100	1280x1024	Macintosh
1152x900	61.80(N)	66.00(N)	94.5	1280x1024	SUN 66
1152x900	71.81(N)	76.14(N)	108	1280x1024	SUN
1280x1024	64.00(P)	60.00(P)	108	1280x1024	VESA
1280x1024	75.83(N)	71.53(N)	128	1280x1024	IBM1
1280x1024	80.00(P)	75.00(P)	135	1280x1024	VESA
1280x1024	81.18(N)	76.16(N)	135.09	1280x1024	SPARC2

"P", "N" stands for "Positive", "Negative" polarity of incoming H-sync/V-sync (input timing)
For each timing detail, please refer to individual video signal standard.

3.6.2 Definition of terms

➤ Video Signal Definition

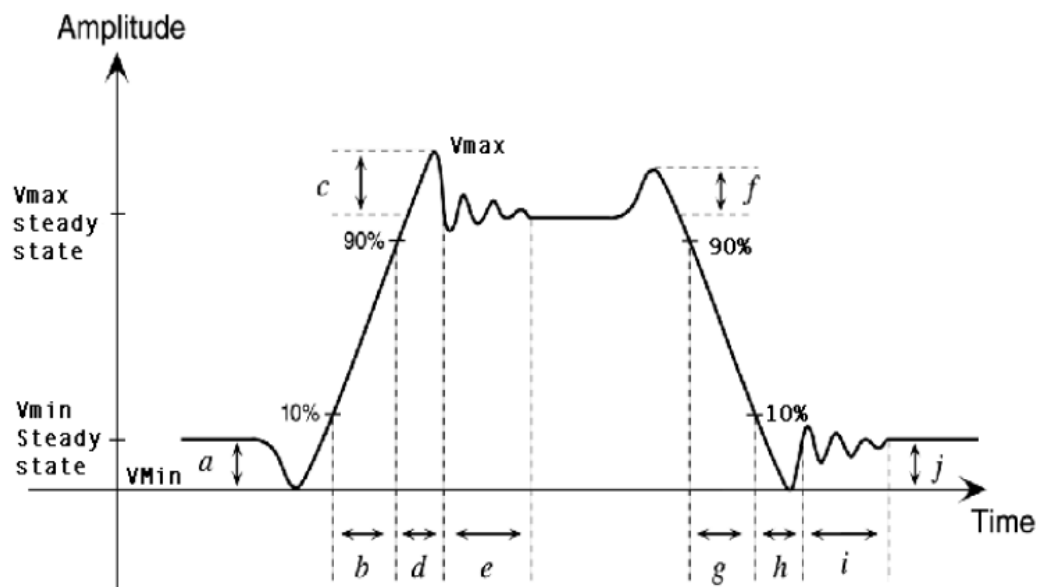

- Vmin steady state Amplitude before transition
- Video Rise Time Delta (t), (measured from the 10% to 90% points of Vmin Steady State to Vmax Steady State)
- Overshoot Amplitude
- Undefined
- Settling Time - Measured from the end of the overshoot to the point where the amplitude of the video ringing is down to +/- 5% of the final steady state value



Product Specification

- f) Undefined
 - g) Video Fall Time Delta (t), (measured from the 90% to 10% points of Vmax Steady State to Vmin Steady State)
 - h) Undefined here, Note: Undershoot is within this period and with an Amplitude of (j)
 - i) Settling Time - Measured from the end of the undershoot to the point where the amplitude of the video ringing is down to +/- 5% of the final steady state value
 - j) Vmin steady state Amplitude after transition
- Synchronization Signal Definition

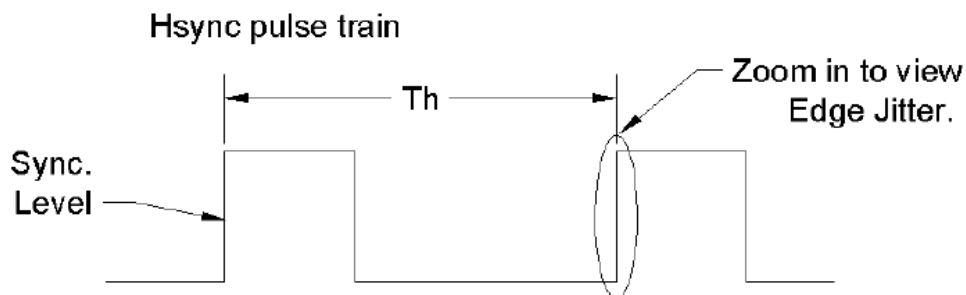

$$(T_h \text{ Max} - T_h \text{ Min}) / 2 < 15\% \text{ of pixel period}$$



M170EP01 V.2

Product Specification

3.7 Power Consumption

Input power specifications are as follows;

Symbol	Parameter	Min	Typ	Max	Units	Condition
VDD	Logic/LCD Drive Voltage	4.9	5.1	5.3	[Volt]	
IDD*	VDD current	-	1100	1500	[mA]	Vin=5.1V ,All Black Pattern.
PDD*	VDD Power		5.6	7.6	[Watt]	Vin=5.1V ,All Black Pattern.
VDDrp	Allowable Logic/LCD Drive Ripple Voltage			100	[mV] p-p	
Power Saving		-	0.4	0.5	[Watt]	Vin=5.1V

*2 line dot inversion

3.8 Power ON/OFF Sequence

Vin and lamp power on/off sequence are as follows. The timing parameters of interface signal are shown in the table below. The signal please reference "3.4 Signal Description".

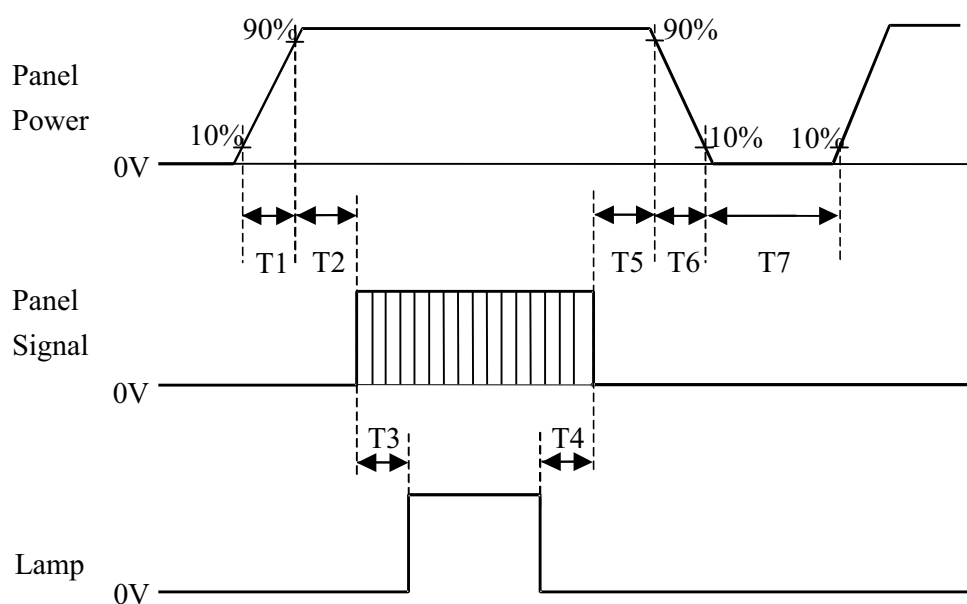

Symbol	Values			Unit
	Min.	Typ.	Max.	
T1	-	0.1	-	ms
T2	5	10	-	ms
T3	200	-	-	ms
T4	100	-	-	ms
T5	0	16	50	ms
T6	-	200	-	ms
T7	1000	-	-	ms



Product Specification

M170EP01 V.2

www.panelook.com



4.0 Backlight Characteristics

4.1 Signal for Lamp connector

	Pin No.	Input	Color	Function
Upper	1	Hot1	Pink	High Voltage
	2	Cold1	White	Low Voltage
	3	Hot2	Blue	High Voltage
	4	Cold2	Black	Low Voltage
Lower	1	Hot1	Pink	High Voltage
	2	Cold1	White	Low Voltage
	3	Hot2	Blue	High Voltage
	4	Cold2	Black	Low Voltage

4.2 Parameter guideline for CCFL Inverter

Symbol	Parameter	Min.	Typ.	Max.	Unit	Condition
ISCFL	CCFL standard current	7.0	7.5	8.5	[mA] rms	(Ta=25°C) Note 1
IRCFL	CCFL operation range	3.0	7.5	8.5	[mA] rms	(Ta=25°C)
FCFL	CCFL Frequency	40	60	80	[KHz]	(Ta=25°C) Note 2
VICFL (0°C)	CCFL Ignition Voltage	1500	-	-	[Volt] rms	(Ta=0°C)
VICF (25°C)	CCFL Ignition Voltage	1150	-	-	[Volt] rms	(Ta=25°C)
VCFL	CCFL Operation Voltage	-	660 @7.5mA	700 @3.0mA	[Volt] rms	(Ta=25°C) Note 3
PCFL	CCFL Power consumption (for reference)	-	19.8	21.8	[Watt]	(Ta=25°C) Note 4
LTCFL	CCFL life Time	40,000	45,000	-	[Hour]	(Ta=25°C) Note 5

Note 1: CCFL standard current is measured at 25±2°C. The variance of the current is ±10%. When lamp current achieve to Max. 8.5mA, brightness will decay more than 7.5mA. But it still could be opened.

Note 2: CCFL Frequency should be carefully determined to avoid interference between inverter and TFT LCD

Note 3: CCFL operation voltage is measured at 25±2°C.

Note 4: The variance of CCFL power consumption is ±10%. Calculator value for reference

(ICFL×VCFL×4=PCFL).

Note 5: CCFL life time is determined as the time at which brightness of lamp is 50%. The typical life time of



Product Specification

M170EP01 V.2

CCFL is on the condition at 7.5mA lamp current.

www.panelook.com



5.0 Vibration, Shock, and Drop

5.1 Vibration & Shock

Vibration Test Spec:

- Frequency: 10 - 200Hz
- Sweep: 30 Minutes each Axis (X, Y, Z)
- Acceleration: 1.5G(10~200Hz P- P)
- Test method:

Acceleration (G)	1.5
Frequency (Hz)	10~200~10
Active time (min)	30

Shock Test Spec:

Acceleration (G) -a	50
Active time -b	20 ms
Wave form	Half-sin
Times	1

- Direction: $\pm X$, $\pm Y$, $\pm Z$

5.2 Drop test

Package test: The drop height is 60cm.



6.0 Environment

The display module will meet the provision of this specification during operating condition or after storage or shipment condition specified below. Operation at 10% beyond the specified range will not cause physical damage to the unit.

6.1 Temperature and Humidity

6.1.1 Operating Conditions

The display module operates error free, when operated under the following conditions;

Temperature	0 °C to 50 °C
Relative Humidity	8% to 95%
Wet Bulb Temperature	39.0 °C

6.1.2 Shipping Conditions

The display module operates error free, after the following conditions;

Temperature	-20 °C to 60 °C
Relative Humidity	5% to 100%
Wet Bulb Temperature	39.0 °C

6.2 Atmospheric Pressure

The display assembly is capable of being operated without affecting its operations over the pressure range as following specified;

	Pressure	Note
Maximum Pressure	1040hPa	(sea level)
Minimum Pressure	674hPa	(3048m)

6.3 Thermal Shock

The display module will not sustain damage after being subjected to 100 cycles of rapid temperature change. A cycle of rapid temperature change consists of varying the temperature from -20°C to 60°C, and back again.

Thermal shock cycle	-20 °C for 30min
	60 °C for 30min

Power is not applied during the test. After temperature cycling, the unit is placed in normal room ambient for at least 4 hours before powering on.



7.0 Reliability

This display module and the packaging of that will comply following standards.

7.1 Failure Criteria

The display assembly will be considered as failing unit when it no longer meets any of the requirements stated in this specification. Only as for maximum white luminance, following criteria is applicable.

- **Maximum white Luminance shall be above 150cd/m².**

7.2 Failure Rate

The average failure rate of the display module (from first power-on cycle till 1,000 hours later) will not exceed 1.0%. The average failure rate of the display module from 1,000 hours until 16,000 hours will not exceed 0.7% per 1000 hours.

7.2.1 Usage

The assumed usage for the above criteria is:

- 220 power-on hours per month
- 500 power on/off cycles per month
- Maximum brightness setting
- Operation to be within office environment (25°C typical)



8.0 Safety

8.1 Sharp Edge Requirements

There will be no sharp edges or comers on the display assembly that could cause injury.

8.2 Materials

8.2.1 Toxicity

There will be no carcinogenic materials used anywhere in the display module. If toxic materials are used, they will be reviewed and approved by the responsible AUO Toxicologist.

8.2.2 Flammability

All components including electrical components that do not meet the flammability grade UL94-V1 in the module will complete the flammability rating exception approval process.

The printed circuit board will be made from material rated 94-V1 or better. The actual UL flammability rating will be printed on the printed circuit board.

8.3 Capacitors

If any polarized capacitors are used in the display assembly, provisions will be made to keep them from being inserted backwards.



Product Specification

M170EP01 V.2

9.0 Other requirement

9.1 National Test Lab Requirement

The display module will satisfy all requirements for compliance to

UL 1950, First Edition
CSA C22.2 No.950-M89
EEC 950
EN 60 950

U.S.A. Information Technology Equipment
Canada, Information Technology Equipment
International, Information Technology Equipment
International, Information Processing Equipment
(European Norm for IEC950)

9.2 Label

The label is on the panel as shown below:

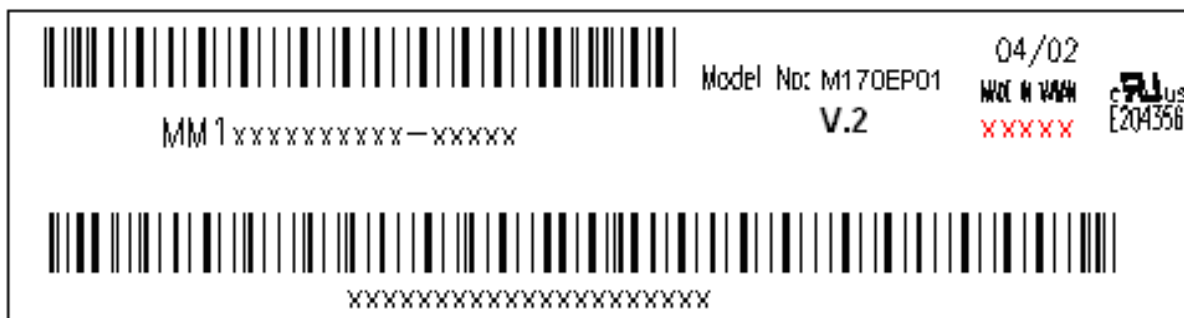

10.0 Mechanical Characteristics

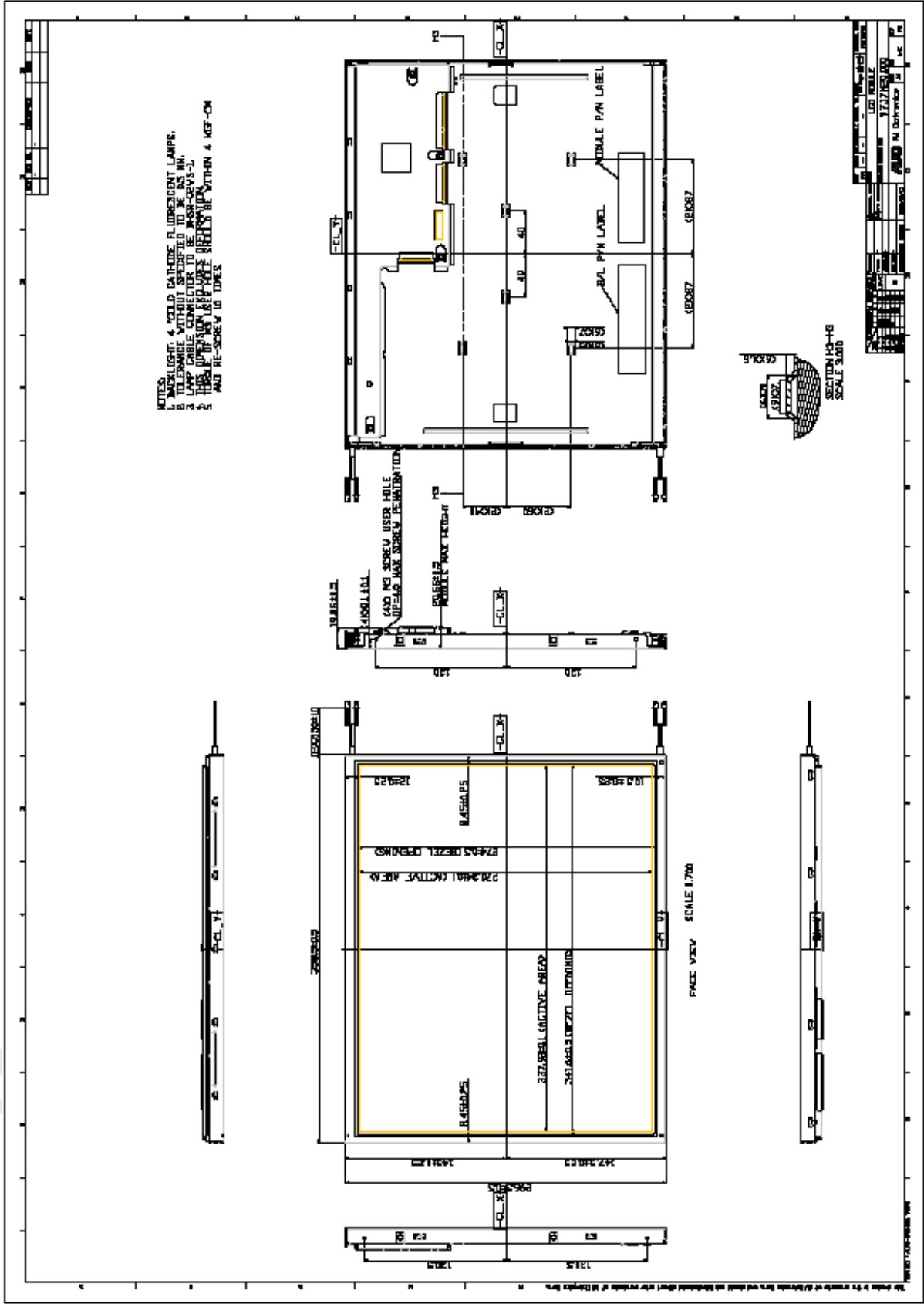

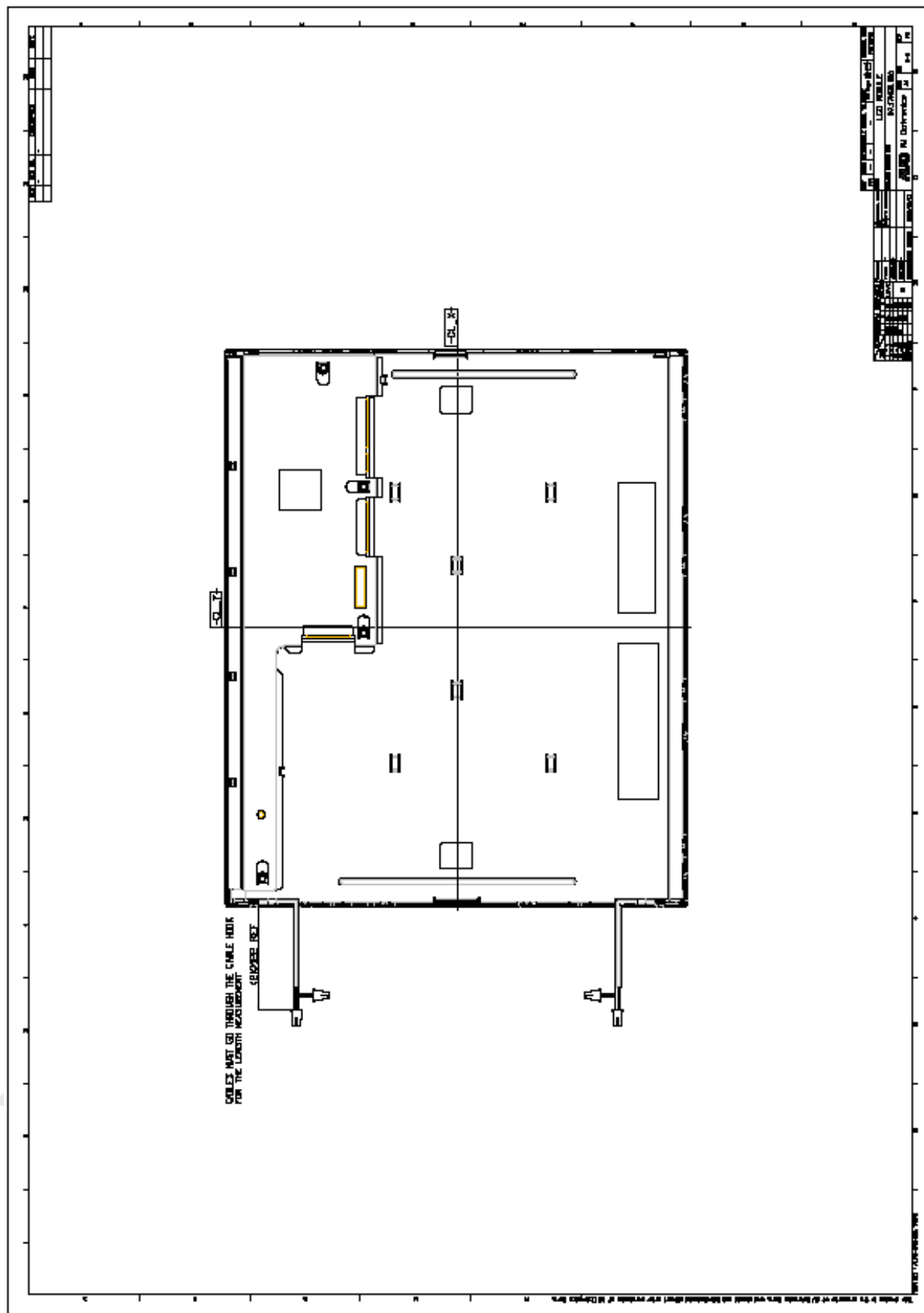

37/26

Ver0.1