



Product Specification

M170ETN01.0

AU OPTRONICS CORPORATION

() Preliminary Specification

(V) Final Specification

Module	17.0" SXGA Color TFT-LCD
Model Name	M170ETN01.0

Customer	Date
_____	_____
Approved by	
<p>Note: This Specification is subject to change without notice.</p>	

Checked & Approved by	Date
<u>Howard Lee</u>	2012/09/26
Prepared by	
<u>Arnold Hsu</u>	2012/09/25
<p>Desktop Display Business Group / AU Optronics corporation</p>	



Product Specification

M170ETN01.0

AU OPTRONICS CORPORATION

Contents

1. Handling Precautions	4
2. General Description	5
2.1 Display Characteristics	5
3. Functional Block Diagram	10
4. Absolute Maximum Ratings	11
4.1 TFT LCD Module	11
4.2 Backlight Unit.....	11
4.3 Absolute Ratings of Environment	11
5. Electrical characteristics	12
5.1 TFT LCD Module	12
5.2 Backlight Unit.....	15
6. Signal Characteristic	16
6.1 Pixel Format Image	16
6.2 The Input Data Format	16
6.4 Timing Characteristics	19
6.5 Power ON/OFF Sequence.....	21
7. Connector & Pin Assignment	22
7.1 TFT LCD Module	22
7.2 Backlight Unit.....	23
8. Reliability Test	24
9. Shipping Label	25
10. Mechanical Characteristics	26



Product Specification

M170ETN01.0

AU OPTRONICS CORPORATION

Record of Revision

Version and Date	Page	Old description	New Description	Remark
0.1 2011/11/15	All	First Edition for Customer	All	
0.2 2011/12/19	6		Update : Optical Characteristics/ Color / Chromaticity Coordinates (CIE) & Color Coordinates (CIE) White	Revised
	14		Update: CCFL Ignition Voltage / Operation Voltage / Power Consumption	
	20		Update Power Sequence Timing	
	21		Update connector Type Part Number	
	25		Update Mechanical Characteristics	
1.0 2012/01/06	All	Final Edition for Customer	All	Revised
1.1 2012/02/06	12		Update: Inrush Current	Revised
1.2 2012/03/05	5		Update : Weight	Revised
1.3 2012/05/11	5		Update : Power Consumption	
	5	Digital Gamma turn on Compliance : TCO5.0	Update : TCO6.0 Compliance	
	14		Update : 5.1.2 Signal Electrical Characteristics	
	20			
	24	Altitude Test Operation: 10,000 ft Non-Operation: 30,000 ft	Altitude Test Operation: 15,000 ft Non-Operation: 40,000 ft	
	24		Note 3 for CCFL model.	Revised
1.4 2012/09/25	19	Timing Characteristics	Update : Timing Characteristics	Revised



1. Handling Precautions

- 1) Since front polarizer is easily damaged, pay attention not to scratch it.
- 2) Be sure to turn off power supply when inserting or disconnecting from input connector.
- 3) Wipe off water drop immediately. Long contact with water may cause discoloration or spots.
- 4) When the panel surface is soiled, wipe it with absorbent cotton or other soft cloth.
- 5) Since the panel is made of glass, it may break or crack if dropped or bumped on hard surface.
- 6) Since CMOS LSI is used in this module, take care of static electricity and insure human earth when handling.
- 7) Do not open or modify the Module Assembly.
- 8) Do not press the reflector sheet at the back of the module to any directions.
- 9) In case if a Module has to be put back into the packing container slot after once it was taken out from the container, do not press the center of the CCFL reflector edge. Instead, press at the far ends of the CCFL Reflector edge softly. Otherwise the TFT Module may be damaged.
- 10) At the insertion or removal of the Signal Interface Connector, be sure not to rotate nor tilt the Interface Connector of the TFT Module.
- 11) After installation of the TFT Module into an enclosure, do not twist nor bend the TFT Module even momentary. At designing the enclosure, it should be taken into consideration that no bending/twisting forces are applied to the TFT Module from outside. Otherwise the TFT Module may be damaged.
- 12) Cold cathode fluorescent lamp in LCD contains a small amount of mercury. Please follow local ordinances or regulations for disposal.
- 13) Small amount of materials having no flammability grade is used in the LCD module. The LCD module should be supplied by power complied with requirements of Limited Power Source (IEC60950 or UL1950), or be applied exemption.
- 14) The LCD module is designed so that the CCFL in it is supplied by Limited Current Circuit (IEC60950 or UL1950). Do not connect the CCFL in Hazardous Voltage Circuit.
- 15) Please avoid touching COF position while you are doing mechanical design.
- 16) When storing modules as spares for a long time, the following precaution is necessary:
Store them in a dark place. Do not expose the module to sunlight or fluorescent light. Keep the temperature between 5°C and 35°C at normal humidity.



Product Specification

M170ETN01.0

AU OPTRONICS CORPORATION

2. General Description

This specification applies to the 17 inch Color TFT-LCD Module M170ETN01.0.

The display supports the SXGA+ (1280(H) x 1024(V)) screen format and 16.7M colors (RGB 6-bits+Hi-FRC data). All input signals are 2 Channel LVDS interface compatible.

This module does not contain an inverter card for backlight.

2.1 Display Characteristics

The following items are characteristics summary on the table under 25 °C condition:

Items	Unit	Specifications
Screen Diagonal	[mm]	432 (17.0")
Active Area	[mm]	337.920(H) × 270.336(V)
Pixels H x V		1280 × 3(RGB) × 1024
Pixel Pitch	[mm]	0.264(per one triad) × 0.264
Pixel Arrangement		R.G.B. Vertical Stripe
Display Mode		Normally White
White Luminance	[cd/m ²]	250 (center, Typ)@7.5 mA
Contrast Ratio		1000 : 1 (Typ)
Optical Response Time	[msec]	5 (Typ)
Nominal Input Voltage VDD	[Volt]	+5.0 (Typ)
Power Consumption (VDD line + CCFL line)	[Watt]	11.05 W VDD line : PDD (typ), All black pattern at 60Hz = 2.35 W CCFL line : PBLU (typ) = 8.7 W
Weight	[Grams]	1850 Typ.
Physical Size (H x V x D)	[mm]	358.5(H) x 296.5(V) Typ. x 15.8(D) Max.
Electrical Interface		Dual Channel LVDS
Surface Treatment		Anti-glare type, Hardness 3H
Support Color		16.7M colors (RGB 6-bits +Hi-FRC data)
Temperature Range Operating Storage (Non-Operating)	[°C] [°C]	0 to +50 -20 to +60
RoHS Compliance		RoHS Compliance
Digital Gamma turn on Compliance		TCO6.0 Compliance



Product Specification

M170ETN01.0

AU OPTRONICS CORPORATION

2.2 Optical Characteristics

The optical characteristics are measured under stable conditions at 25°C (Room Temperature):

Item	Unit	Conditions	Min.	Typ.	Max.	Note
Viewing Angle	[degree]	Horizontal (Right) CR = 10 (Left)	140	170	-	1
		Vertical (Up) CR = 10 (Down)	140	160	-	
Luminance Uniformity	[%]	9 Points	75	80	-	2, 3
Optical Response Time	[msec]	Rising	-	3.5	6	4, 6
		Falling	-	1.5	3	
		Rising + Falling	-	5	9	
Color / Chromaticity Coordinates (CIE 1931)		Red x	0.623	0.653	0.683	4
		Red y	0.298	0.328	0.358	
		Green x	0.273	0.303	0.333	
		Green y	0.578	0.608	0.638	
		Blue x	0.114	0.144	0.174	
		Blue y	0.034	0.064	0.094	
White x		White x	0.283	0.313	0.343	
		White y	0.299	0.329	0.359	
White Luminance (At CCFL= 7.5mA)	[cd/m ²]		200	250	-	4
Contrast Ratio			600	1000	-	4
Cross Talk (At 75Hz)	[%]		-	-	1.5	5
Flicker	[dB]		-	-	-20	7

Optical Equipment: BM-5A, BM-7, PR880, or equivalent



Product Specification

M170ETN01.0

AU OPTRONICS CORPORATION

Note 1: Definition of viewing angle

Viewing angle is the measurement of contrast ratio ≥ 10 , at the screen center, over a 180° horizontal and 180° vertical range (off-normal viewing angles). The 180° viewing angle range is broken down as follows; 90° (θ) horizontal left and right and 90° (Φ) vertical, high (up) and low (down). The measurement direction is typically perpendicular to the display surface with the screen rotated about its center to develop the desired measurement viewing angle.

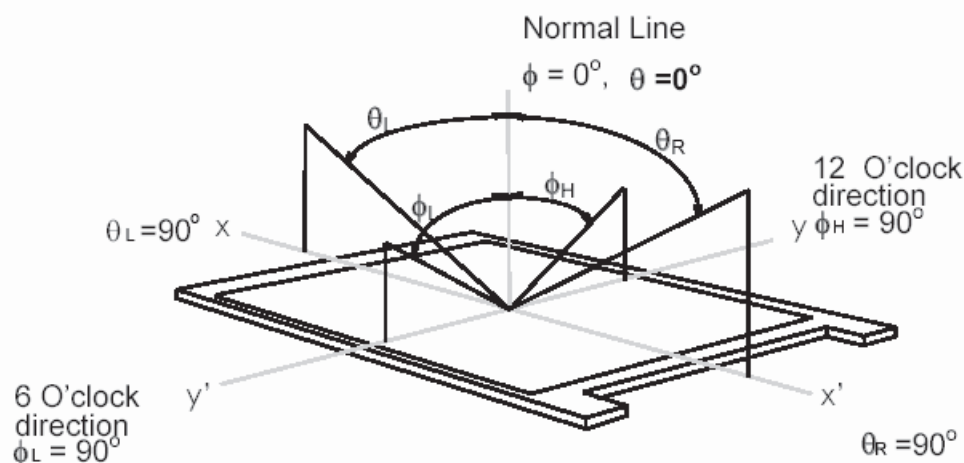

Note 2: 9 points position

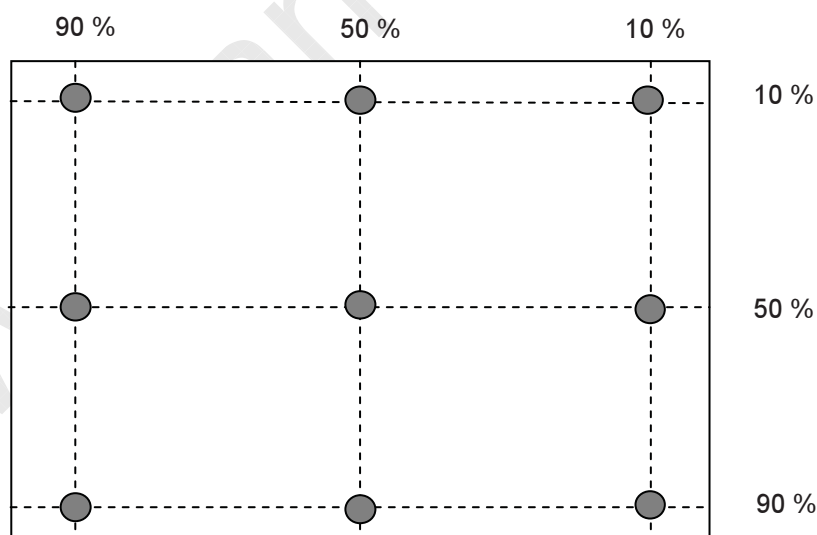

Note 3: The luminance uniformity of 9 points is defined by dividing the maximum luminance values by the minimum test point luminance

$$\delta_{w9} = \frac{\text{Minimum Luminance of 9 points}}{\text{Maximum Luminance of 9 points}}$$



Product Specification

M170ETN01.0

AU OPTRONICS CORPORATION

Note 4: Measurement method

The LCD module should be stabilized at given temperature for 30 minutes to avoid abrupt temperature change during measuring. In order to stabilize the luminance, the measurement should be executed after lighting Backlight for 30 minutes in a stable, windless and dark room.

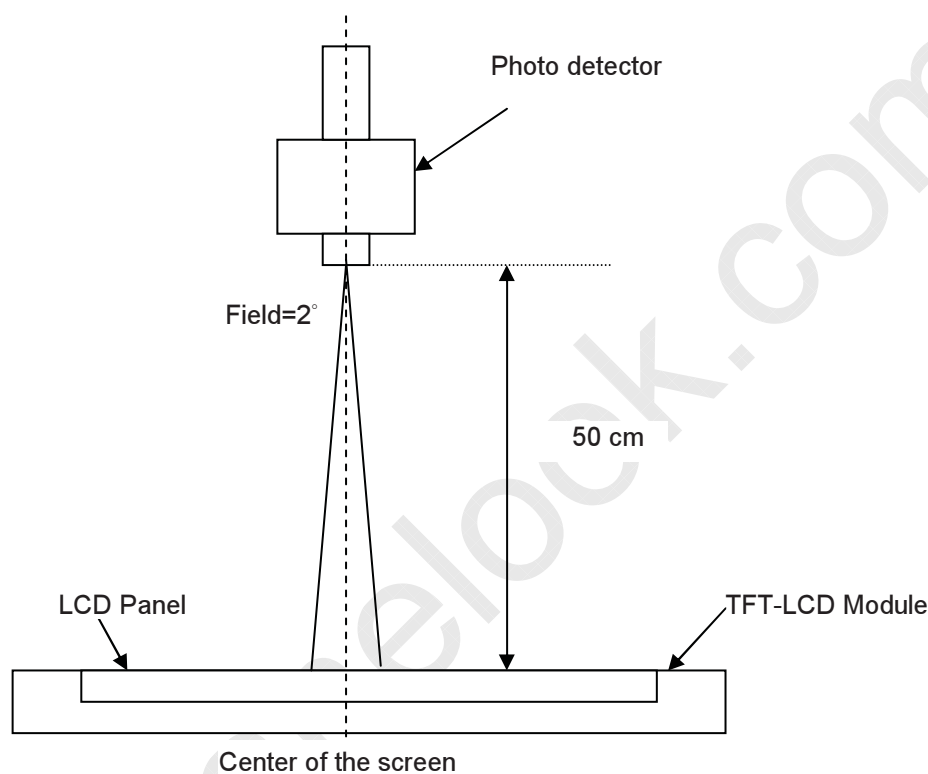

Note 5: Definition of Cross Talk (CT)

$$CT = |Y_B - Y_A| / Y_A \times 100 (\%)$$

Where

Y_A = Luminance of measured location without gray level 0 pattern (cd/m²)

Y_B = Luminance of measured location with gray level 0 pattern (cd/m²)

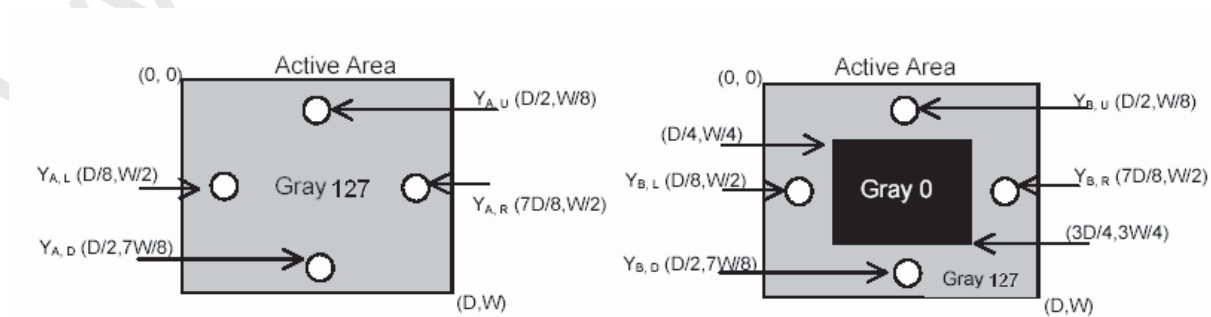



Product Specification

M170ETN01.0

AU OPTRONICS CORPORATION

Note 6: Definition of response time:

The output signals of photo detector are measured when the input signals are changed from “Full Black” to “Full White” (rising time, T_{rF}), and from “Full White” to “Full Black” (falling time, T_{rR}), respectively. The response time is interval between the 10% and 90% of amplitudes. Please refer to the figure as below.

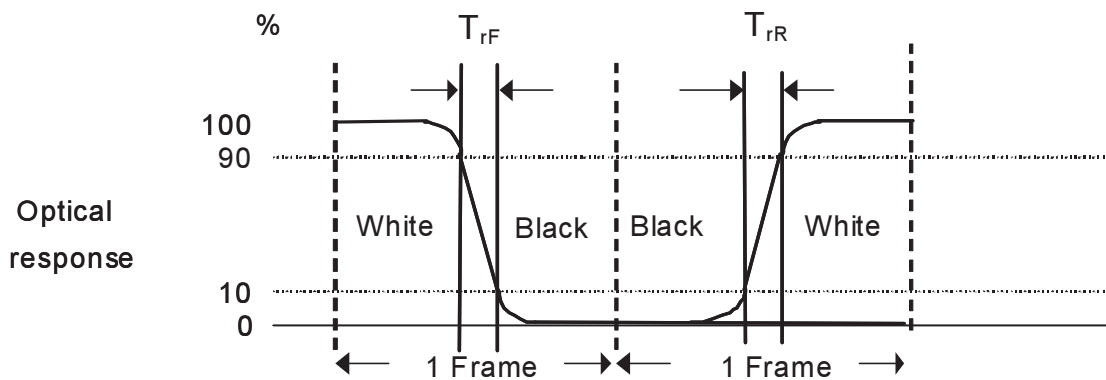

$T_{rR} + T_{rF} = 5$ msec (typ.).

Algorithm: \square Gray Level A – Gray Level B \square \square 16, then the average gray to gray response time is 2 ms, (F= 60 Hz).

Note 7: Test pattern: Subchecker Pattern (Measured by TOPCON SR-3)

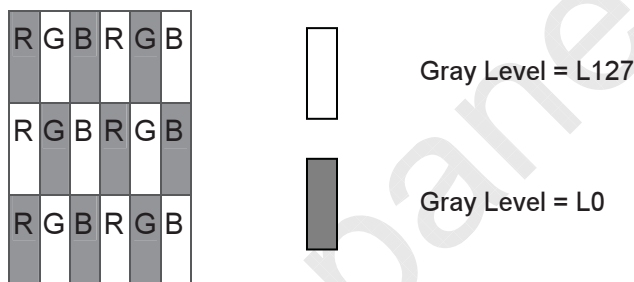

Method: Record dBV & DC value with (WESTAR)TRD-100

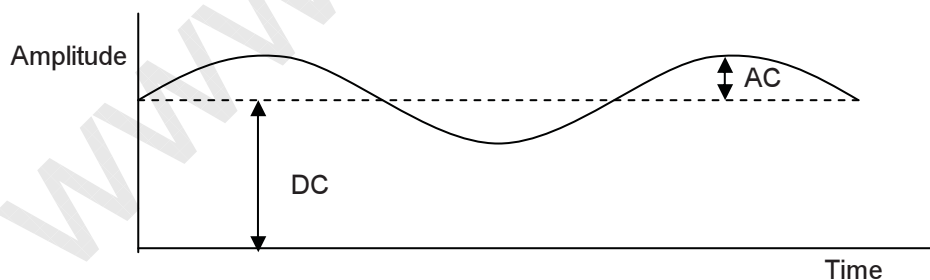

$$\text{Flicker (dB)} = 20 \log \frac{\text{AC Level(at 30 Hz)}}{\text{DC Level}}$$



Product Specification

M170ETN01.0

AU OPTRONICS CORPORATION

3. Functional Block Diagram

The following diagram shows the functional block of the 17.0 inches Color TFT-LCD Module:

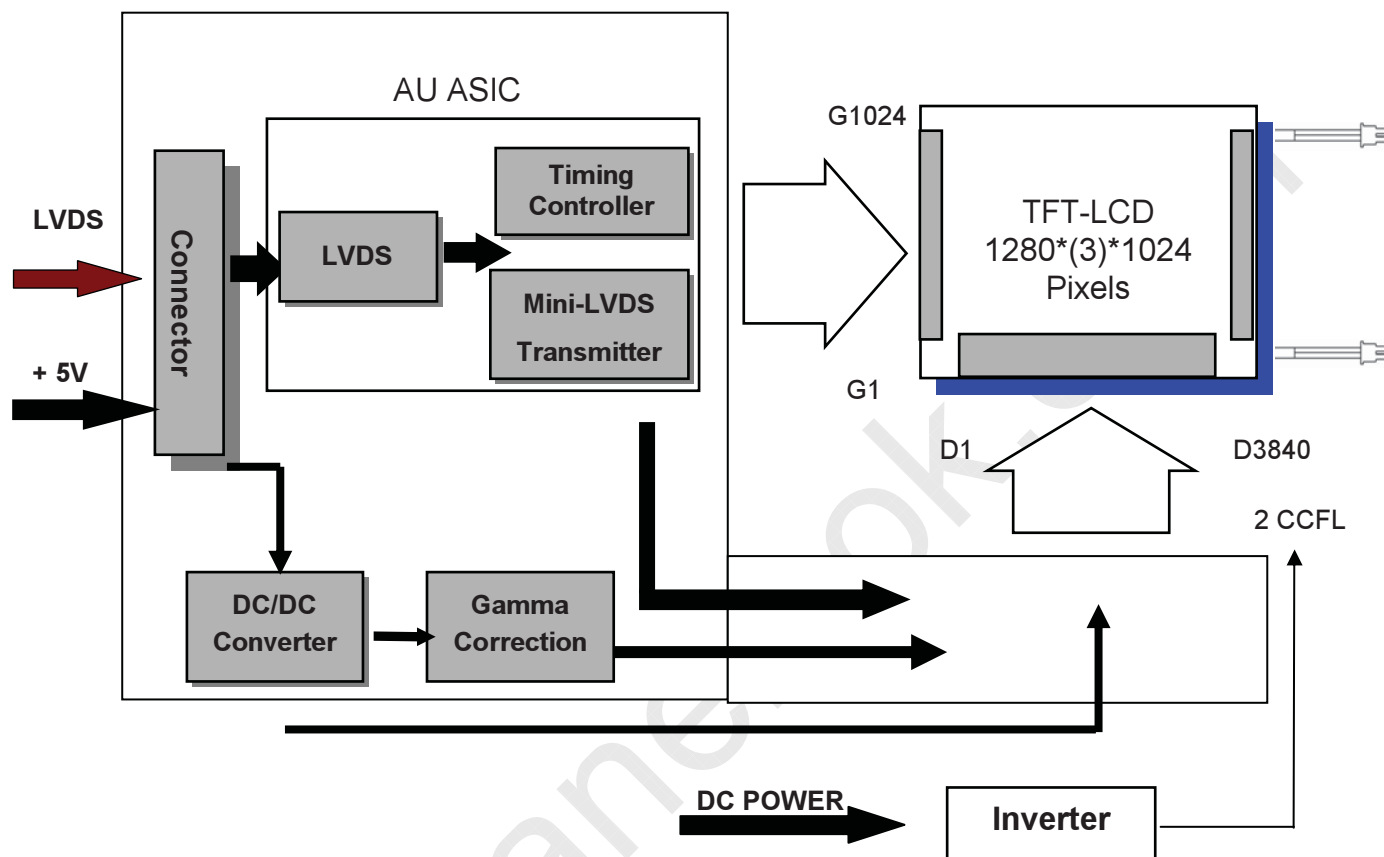

I/F PCB Interface:

JAE FI-XB30SSLA-HF15
 P-TWO 187034-30091
 STM MSBKT2407P30HB

CCFL Connector:

YEONHO 35001HS-02L
 CVILUX CP0502SL090

Mating Type:

FI-X30HL (Locked Type)
 FI-X30H (Unlocked Type)



Product Specification

M170ETN01.0

AU OPTRONICS CORPORATION

4. Absolute Maximum Ratings

Absolute maximum ratings of the module is as following:

4.1 TFT LCD Module

Item	Symbol	Min	Max	Unit	Conditions
Logic/LCD Drive Voltage	VIN	-0.3	6	[Volt]	Note 1,2

4.2 Backlight Unit

Item	Symbol	Min	Max	Unit	Conditions
CCFL Current	ICFL	-	8	[mA] rms	Note 1,2

4.3 Absolute Ratings of Environment

Item	Symbol	Min	Max	Unit	Conditions
Operating Humidity	HOP	5	90	[%RH]	Note 3
Storage Temperature	TST	-20	+60	[°C]	
Storage Humidity	HST	5	90	[%RH]	

Note 1: With in Ta (25°C)

Note 2: Permanent damage to the device may occur if exceed maximum values

Note 3: For quality performance, please refer to AUO IIS (Incoming Inspection Standard).

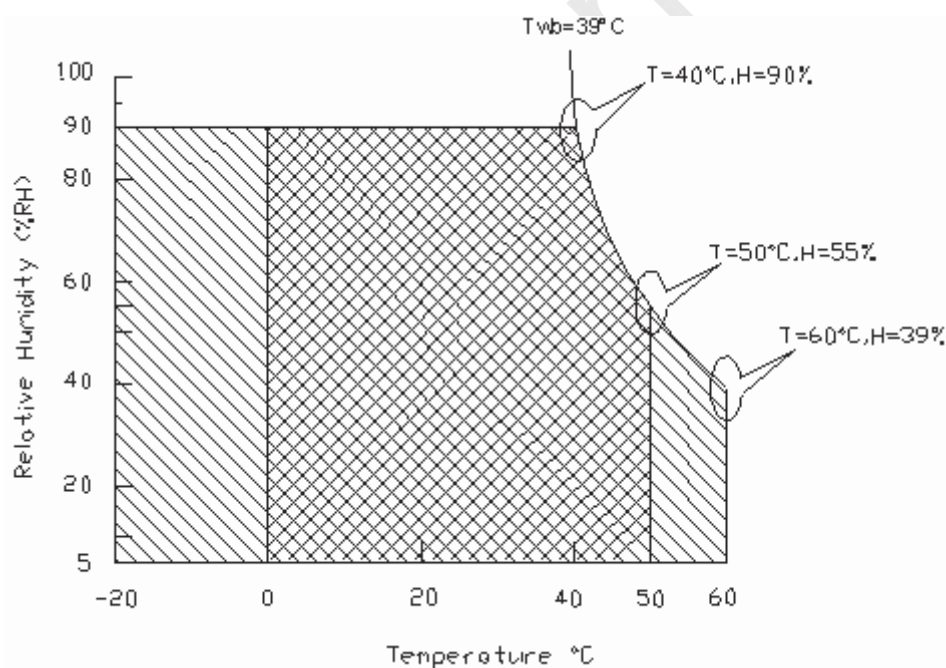

Operating Range



Storage Range





Product Specification

M170ETN01.0

AU OPTRONICS CORPORATION

5.1.2 Signal Electrical Characteristics

(1) DC Characteristics of each signal are as following:

Symbol	Parameter	Min	Typ	Max	Units	Condition
V_{TH}	Differential Input High Threshold	-	-	+100	[mV]	$V_{ICM} = 1.2V$ Note
V_{TL}	Differential Input Low Threshold	-100	-	-	[mV]	$V_{ICM} = 1.2V$ Note
$ V_{ID} $	Input Differential Voltage	100	400	600	[mV]	Note
V_{ICM}	Differential Input Common Mode Voltage	+1.0	+1.2	+1.5	[V]	$V_{TH}-V_{TL} = 200mV(\min)$ Note

Note: LVDS Signal Waveform

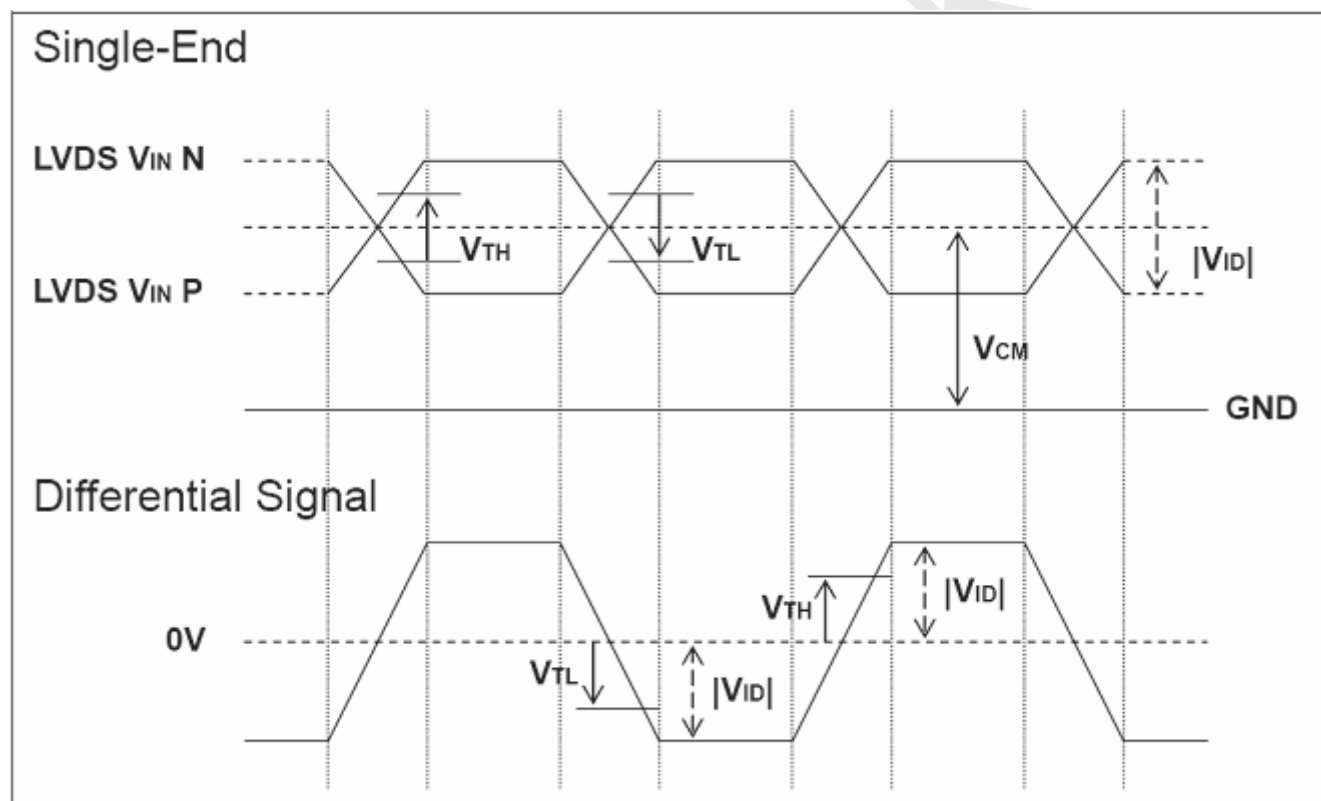



Product Specification

M170ETN01.0

AU OPTRONICS CORPORATION

(2) AC Characteristics

Symbol	Description	Min	Max	Units	Conditions
F_{DEV}	Maximum deviation of input clock frequency during SSC	-	± 3	%	
F_{MOD}	Maximum modulation frequency of input clock during SSC	-	200	KHz	

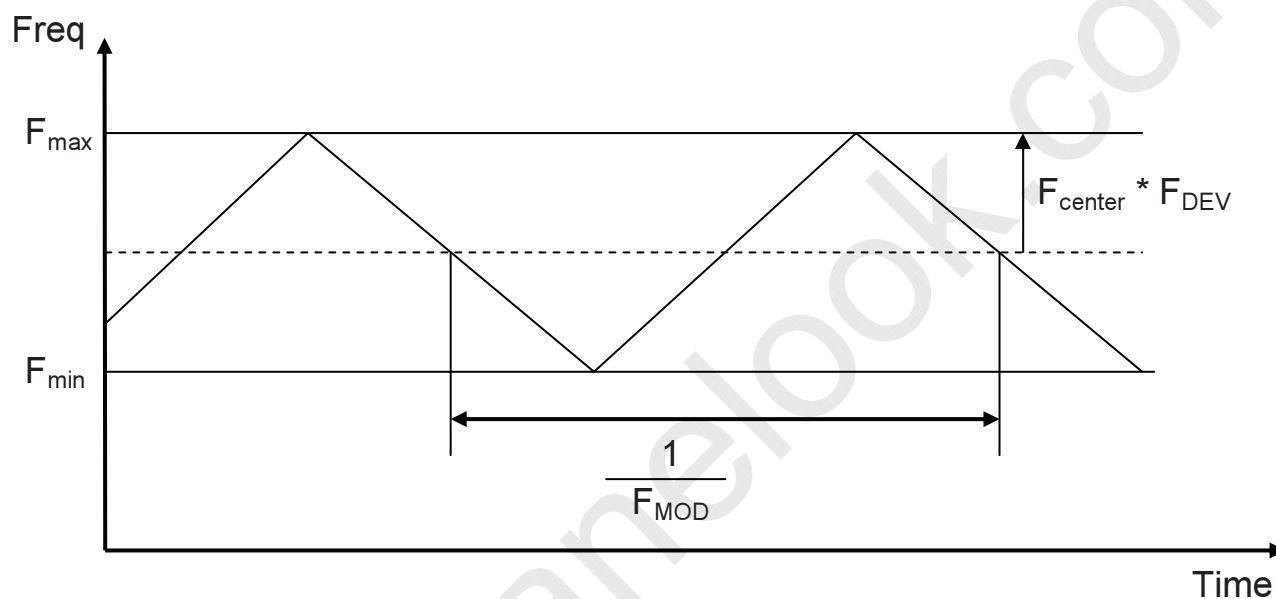

< Spread Spectrum >



Product Specification

M170ETN01.0

AU OPTRONICS CORPORATION

5.2 Backlight Unit

Parameter guideline for CCFL Inverter

Parameter	Min.	Typ.	Max.	Unit	Condition
CCFL standard current(ISCFL)	7	7.5	8	[mA] rms	(Ta=25°C) Note 2
CCFL Operation Current (IRCFL)	3.5	7.5	8	[mA] rms	(Ta=25°C) Note 2
CCFL Frequency (FCFL)	40	60	80	[KHz]	(Ta=25°C) Note 3,4
CCFL Ignition Voltage (ViCFL, Ta= 0°C)	1230	-		[Volt] rms	(Ta=0°C) Note 5
CCFL Ignition Voltage (ViCF, Ta= 25°C)	1025	-		[Volt] rms	(Ta=25°C) Note 5
CCFL Operation Voltage (VCFL)	528 @ 7.5mA	580 @ 7.5mA	638 @ 7.5mA	[Volt] rms	(Ta=25°C) Note 6
CCFL Power Consumption (PCFL)	7.92	8.7	9.57	[Watt]	(Ta=25°C) Note 6
CCFL Life Time (LTCFL)	50,000	-	-	[Hour]	(Ta=25°C)

Note 1: Typ. are AUO recommended design points.

- *1 All of characteristics listed are measured under the condition using the AUO test inverter.
- *2 In case of using an inverter other than listed, it is recommended to check the inverter carefully. Sometimes, interfering noise stripes appear on the screen, and substandard luminance or flicker at low power may happen.
- *3 In designing an inverter, it is suggested to check safety circuit very carefully. Impedance of CCFL, for instance, becomes more than 1 [M ohm] when CCFL is damaged.
- *4 Generally, CCFL has some amount of delay time after applying kick-off voltage. It is recommended to keep on applying kick-off voltage for 1 [Sec] until discharge.
- *5 Reducing CCFL current increases CCFL discharge voltage and generally increases CCFL discharge frequency. So all the parameters of an inverter should be carefully designed so as not to produce too much leakage current from high-voltage output of the inverter.

Note 2: It should be employed the inverter which has "Duty Dimming", if IRCFL is less than 3mA.

Note 3: CCFL discharge frequency should be carefully determined to avoid interference between inverter and TFT LCD.

Note 4: The frequency range will not affect to lamp life and reliability characteristics.

Note 5: CCFL inverter should be able to give out a power that has a generating capacity of over 1,560 voltage. Lamp units need 1,560 voltage minimum for ignition.

Note 6: The variance of CCFL power consumption is $\pm 10\%$. Calculator value for reference (ISCFL \times VCFL \times 2= PCFL)

Note 7: Definition of Life time: Brightness becomes 50%. The typical life time CCFL in on the condition at 7.5 m A lamp current.



Product Specification

M170ETN01.0

AU OPTRONICS CORPORATION

6. Signal Characteristic

6.1 Pixel Format Image

Following figure shows the relationship of the input signals and LCD pixel format.

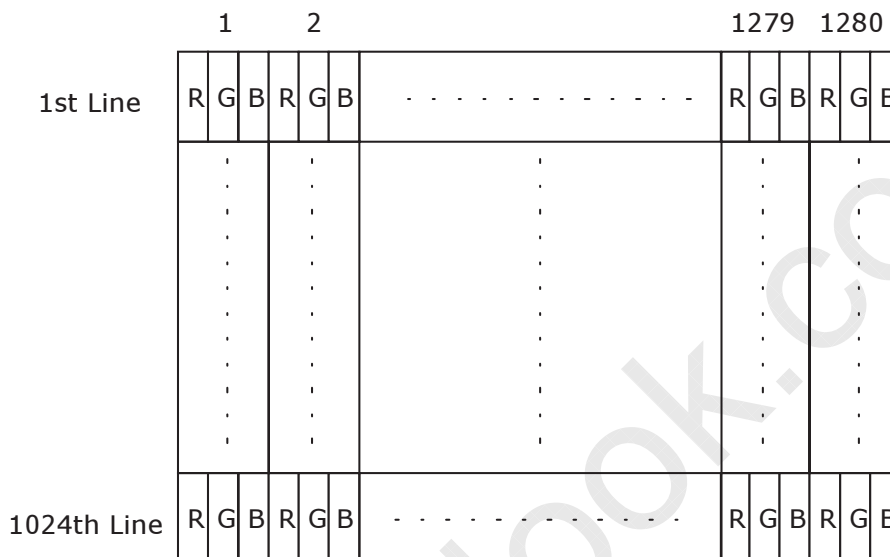

6.2 The Input Data Format

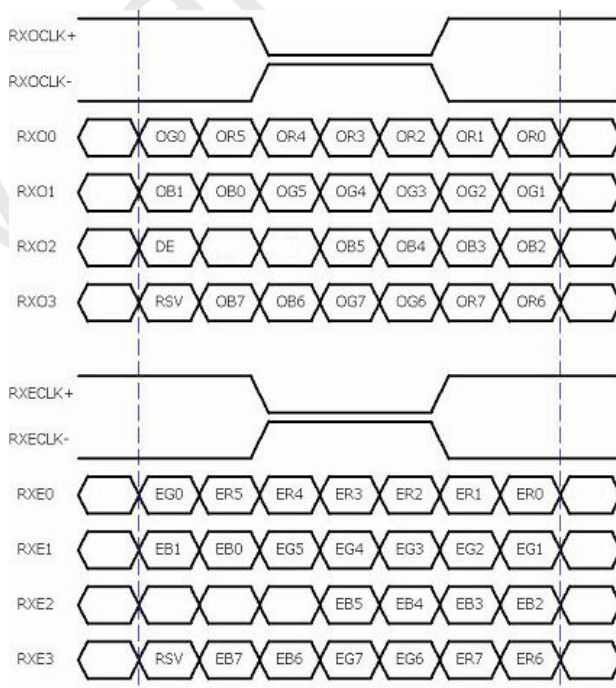

Note1: Normally, DE, VS, HS on EVEN channel are not used.

Note2: Please follow PSWG.



Product Specification

M170ETN01.0

AU OPTRONICS CORPORATION

Note3: 8-bit in

6.3 Signal Description

PIN #	SIGNAL NAME	DESCRIPTION
1	RXO0-	Negative LVDS differential data input (Odd data)
2	RXO0+	Positive LVDS differential data input (Odd data)
3	RXO1-	Negative LVDS differential data input (Odd data)
4	RXO1+	Positive LVDS differential data input (Odd data)
5	RXO2-	Negative LVDS differential data input (Odd data, H-Sync,V-Sync,DSPTMG)
6	RXO2+	Positive LVDS differential data input (Odd data, H-Sync,V-Sync,DSPTMG)
7	GND	Power Ground
8	RXOCLK-	Negative LVDS differential clock input (Odd clock)
9	RXOCLK+	Positive LVDS differential clock input (Odd clock)
10	RXO3-	Negative LVDS differential data input (Odd data)
11	RXO3+	Positive LVDS differential data input (Odd data)
12	RXE0-	Negative LVDS differential data input (Even data)
13	RXE0+	Positive LVDS differential data input (Even data)
14	GND	Power Ground
15	RXE1-	Negative LVDS differential data input (Even data)
16	RXE1+	Positive LVDS differential data input (Even data)
17	GND	Power Ground
18	RXE2-	Negative LVDS differential data input (Even data)
19	RXE2+	Positive LVDS differential data input (Even data)
20	RXECLK-	Negative LVDS differential clock input (Even clock)
21	RXECLK+	Positive LVDS differential clock input (Even clock)
22	RXE3-	Negative LVDS differential data input (Even data)
23	RXE3+	Positive LVDS differential data input (Even data)
24	GND	Power Ground
25	GND	Power Ground (For AUO test Aging+HVS mode)
26	NC	No contact
27	GND	Power Ground
28	VCC	+5.0V Power Supply
29	VCC	+5.0V Power Supply
30	VCC	+5.0V Power Supply

Note 1: Input signals of odd and even clock shall be the same timing.



Product Specification

M170ETN01.0

AU OPTRONICS CORPORATION

Note1: Start from left side

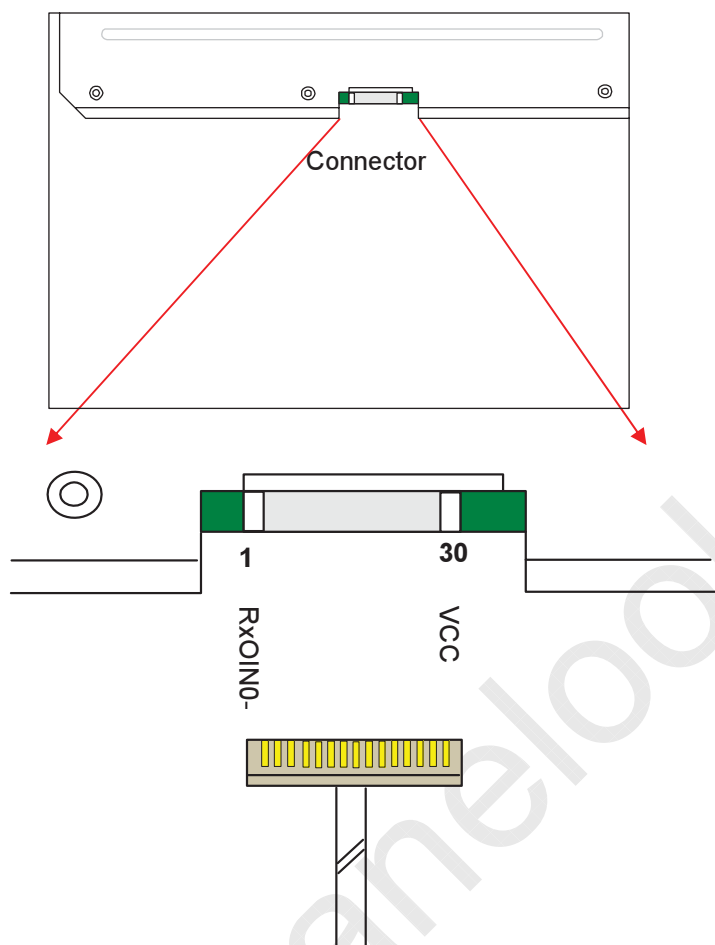

Note2: Input signals of odd and even clock shall be the same timing.

Note3: Please follow PSWG.



Product Specification

M170ETN01.0

AU OPTRONICS CORPORATION

6.4 Timing Characteristics

6.4.1 Timing Characteristics

The input signal timing specifications are shown as the following table

Signal	Item	Symbol	Min	Typ	Max	Unit
Vertical Section	Period	T_v	1036	1066	1873	Th
	Active	$T_{disp(v)}$	1024	1024	1024	Th
	Blanking	$T_{bp(v)}+T_{fp(v)}+PW_{vs}$	12	42	849	Th
Horizontal Section	Period	T_h	730	844	1320	Tclk
	Active	$T_{disp(h)}$	640	640	640	Tclk
	Blanking	$T_{bp(h)}+T_{fp(h)}+PW_{hs}$	90	204	680	Tclk
Clock	Period	Tclk	14.6	18.5	26.4	ns
	Frequency	Freq	37.8	54.0	68.4	MHz
Frame rate	Frame rate	F	50	60	76	Hz

Note : DE mode only



Product Specification

M170ETN01.0

AU OPTRONICS CORPORATION

6.4.2 Timing Diagram

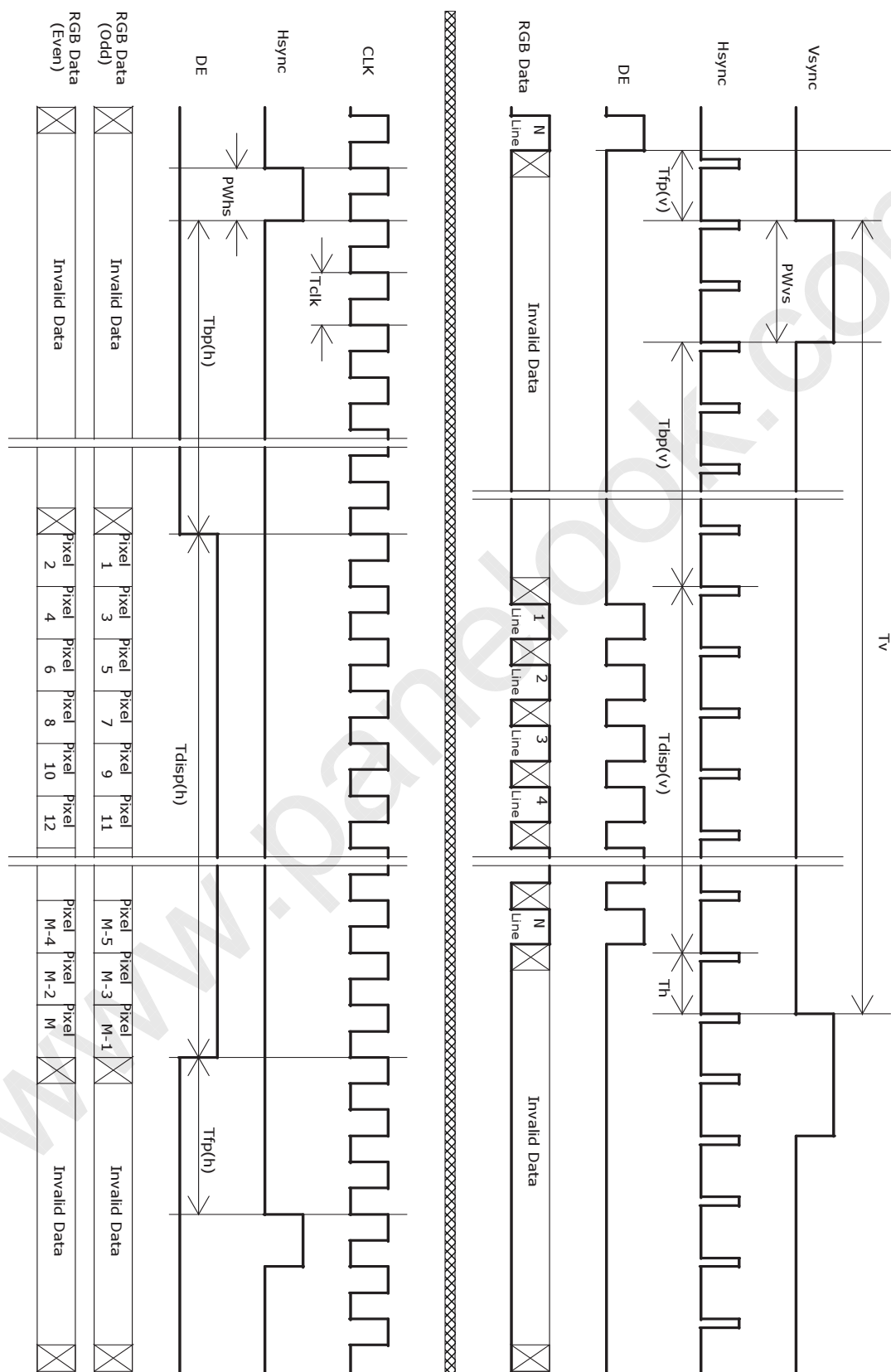



Product Specification

M170ETN01.0

AU OPTRONICS CORPORATION

6.5 Power ON/OFF Sequence

VDD power and lamp on/off sequence is as follows. Interface signals are also shown in the chart. Signals from any system shall be Hi-Z state or low level when VDD is off.

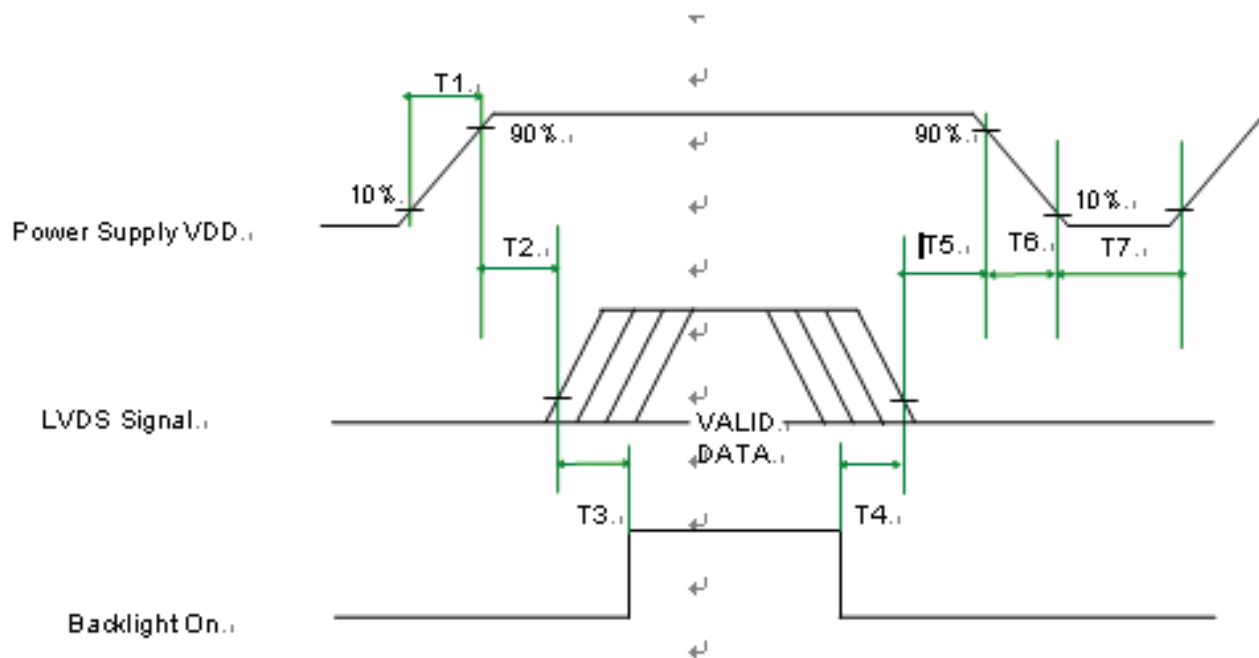

Power Sequence Timing

Parameter	Value			Unit
	Min.	Typ.	Max.	
T1	0.5	-	10	[ms]
T2	0	-	50	[ms]
T3	500	-	-	[ms]
T4	100	-	-	[ms]
T5	0	-	50	[ms] Note1,2
T6	5	-	100	[ms] Note1,2
T7	1000	-	-	[ms]

Note1 : Recommend setting T5 = 0ms to avoid electronic noise when VDD is off.

Note2 : During T5 and T6 period , please keep the level of input LVDS signals with Hi-Z state.



Product Specification

M170ETN01.0

AU OPTRONICS CORPORATION

7. Connector & Pin Assignment

Physical interface is described as for the connector on module. These connectors are capable of accommodating the following signals and will be following components.

7.1 TFT LCD Module

7.1.1 Connector

Connector Name / Designation	Interface Connector / Interface card
Manufacturer	JAE / P-TWO / STM
Type Part Number	FI-XB30SSLA-HF15/187034-3009/ MSBKT2407P30HB
Mating Housing Part Number	JAE FI-X30HL

7.1.2 Pin Assignment

Pin#	Signal Name	Pin#	Signal Name
1	RXO0-	2	RXO0+
3	RXO1-	4	RXO1+
5	RXO2-	6	RXO2+
7	GND	8	RXOCLK-
9	RXOCLK+	10	RXO3-
11	RXO3+	12	RXE0-
13	RXE0+	14	GND
15	RXE1-	16	RXE1+
17	GND	18	RXE2-
19	RXE2+	20	RXECLK-
21	RXECLK+	22	RXE3-
23	RXE3+	24	GND
25	GND (AGMODE+HVS)	26	NC
27	GND	28	VCC
29	VCC	30	VCC



Product Specification

M170ETN01.0

AU OPTRONICS CORPORATION

7.2 Backlight Unit

Physical interface is described as for the connector on module. These connectors are capable of accommodating the following signals and will be following components.

Connector Name / Designation	Lamp Connector / Backlight lamp
Manufacturer	YEONHO or CVILUX
Type Part Number	35001HS-02L or CP0502SL090
Mating Type Part Number	35001WR-02L or CP0502P1ML0

7.2.1 Signal for Lamp connector

	Connector No.	Pin No.	Input	Color	Function
Upper	CN1	1	Hot1	Pink	High Voltage (Lamp 1)
		2	Cold1	White	Low Voltage (Lamp 1)

	Connector No.	Pin No.	Input	Color	Function
Lower	CN2	1	Hot1	Pink	High Voltage (Lamp 2)
		2	Cold1	White	Low Voltage (Lamp 2)



Product Specification

M170ETN01.0

AU OPTRONICS CORPORATION

8. Reliability Test

Environment test conditions are listed as following table.

Items	Required Condition	Note
Temperature Humidity Bias (THB)	Ta= 50□, 80%RH, 300hours	
High Temperature Operation (HTO)	Ta= 50□, 50%RH, 300hours	
Low Temperature Operation (LTO)	Ta= 0□, 300hours	
High Temperature Storage (HTS)	Ta= 60□, 300hours	
Low Temperature Storage (LTS)	Ta= -20□, 300hours	
Vibration Test (Non-operation)	Acceleration: 1.5 G Wave: Random Frequency: 10 - 200 - 10 Hz Sweep: 30 Minutes each Axis (X, Y, Z)	
Shock Test (Non-operation)	Acceleration: 50 G Wave: Half-sine Active Time: 20 ms Direction: ±X, ±Y, ±Z (one time for each Axis)	
Drop Test	Height: 60 cm, package test	
Thermal Shock Test (TST)	-20□/30min, 60□/30min, 100 cycles	Note 1
On/Off Test	On/10sec, Off/10sec, 30,000 cycles	
ESD (ElectroStatic Discharge)	Contact Discharge: ± 15KV, 150pF(330Ω) 1sec, 8 points, 25 times/ point.	Note 2
	Air Discharge: ± 15KV, 150pF(330Ω) 1sec 8 points, 25 times/ point.	
Altitude Test	Operation: 15,000 ft Non-Operation: 40,000 ft	Note 3

Note 1: The TFT-LCD module will not sustain damage after being subjected to 100 cycles of rapid temperature change. A cycle of rapid temperature change consists of varying the temperature from -20°C to 60°C, and back again. Power is not applied during the test. After temperature cycling, the unit is placed in normal room ambient for at least 4 hours before power on.

Note 2: EN61000-4-2, ESD class B: Certain performance degradation allowed:

- No data lost
- Self-recoverable
- No hardware failures

Note 3: *It's not available to use reversed-phase driving on CCFL set (high risk).*



Product Specification

M170ETN01.0

AU OPTRONICS CORPORATION

9. Shipping Label

The shipping label format is shown as below.

	Manufactured XX/XX Model No: M170ETN01.0 AU Optronics XXXXX MADE IN XXXXXX (XX)		
<p>*XXXXXXXXXXXX-XXXX*</p>			
	<p>XXXXXXXXXXXXXXXXXXXX</p>		

www.panelook.com

