

TFT LCD Approval Specification

MODEL NO.: M180E2 - L01

Customer: Sony Corporation Display Network Company

Approved by: _____

Note:

Liquid Crystal Display Division		
QRA Dept.	PDD II Dept.	PD Dept.
Approval	Approval	Approval
		

- CONTENTS -

REVISION HISTORY	-----	3
1. GENERAL DESCRIPTION	-----	4
1.1 OVERVIEW		
1.2 FEATURES		
1.3 APPLICATION		
1.4 GENERAL SPECIFICATIONS		
1.5 MECHANICAL SPECIFICATIONS		
2. ABSOLUTE MAXIMUM RATINGS	-----	5
2.1 ABSOLUTE RATINGS OF ENVIRONMENT		
2.2 ELECTRICAL ABSOLUTE RATINGS		
2.2.1 TFT LCD MODULE		
2.2.2 BACKLIGHT UNIT		
3. ELECTRICAL CHARACTERISTICS	-----	7
3.1 TFT LCD MODULE		
3.2 BACKLIGHT UNIT		
4. BLOCK DIAGRAM	-----	10
4.1 TFT LCD MODULE		
4.2 BACKLIGHT UNIT		
5. INPUT TERMINAL PIN ASSIGNMENT	-----	11
5.1 TFT LCD MODULE		
5.2 BACKLIGHT UNIT		
5.3 TIMING DIAGRAM OF LVDS INPUT SIGNAL		
5.4 COLOR DATA INPUT ASSIGNMENT		
6. INTERFACE TIMING	-----	14
6.1 INPUT SIGNAL TIMING SPECIFICATIONS		
6.2 POWER ON/OFF SEQUENCE		
7. OPTICAL CHARACTERISTICS	-----	16
7.1 TEST CONDITIONS		
7.2 OPTICAL SPECIFICATIONS		
8. PRECAUTIONS	-----	20
8.1 ASSEMBLY AND HANDLING PRECAUTIONS		
8.2 SAFETY PRECAUTIONS		
9. Packaging	-----	21
9.1 PACKING SPECIFICATIONS		
9.2 PACKING METHOD		
10. INCOMING INSPECTION DAY	-----	23
11. DEFINITION OF SHIPPING LABEL ON MODULE	-----	24
12. RELIABILITY ENVIRONMENT TEST CONDITION	-----	25
13. MECHANICAL CHARACTERISTICS	-----	26

REVISION HISTORY

Version	Date	Page (New)	Section	Description
Ver 2.0	Sep.,06,'01	All	All	Preliminary Specification was first issued.
Ver 3.0	Oct.,30,'01	All	All	Approval Specification was first issued.
		2	2.1	Add Altitude (Operation) specification.
		8	3.2	Add Lamp Wire length specification.
		12	7.2	Change chromaticity specification: Red x: 0.603/0.633/0.663 → 0.611/0.631/0.651 Red y: 0.323/0.353/0.383 → 0.339/0.359/0.379 Green x: 0.264/0.294/0.324 → 0.281/0.301/0.321 Green y: 0.562/0.592/0.622 → 0.575/0.595/0.615 Blue x: 0.112/0.142/0.172 → 0.125/0.145/0.165 Blue y: 0.067/0.097/0.127 → 0.078/0.098/0.118
25	12	Add reliability environment test condition table		
Ver 3.1	Jul.,18,'02	27	13	Change mechanical drawing of lamp wire length from 150→125 (mm).
		24	11	Revised Manufactured Date Month:0-9→1-9
				Revised Manufactured Date Day:0-9→1-9 and add U.

1. GENERAL DESCRIPTION

1.1 OVERVIEW

M180E2 - 01 is an 18.0" TFT Liquid Crystal Display module with 4 CCFL Backlight unit and 2ch-LVDS interface. This module supports 1280 x 1024 SXGA mode and can display 16M colors. The inverter module for Backlight is not built in.

1.2 FEATURES

- Wide viewing angle
- High contrast ratio
- Fast response time
- High color saturation
- SXGA (1280 x 1024 pixels) resolution
- DE (Data Enable) only mode
- LVDS (Low Voltage Differential Signaling) interface

1.3 APPLICATION

- TFT LCD Monitor

1.4 GENERAL SPECIFICATIONS

Item	Specification	Unit	Note
Active Area	357.12 (H) x 285.696 (V) (18.0" diagonal)	mm	(1)
Bezel Opening Area	361.1 (H) x 289.7 (V)	mm	
Driver Element	a-si TFT active matrix	-	-
Pixel Number	1280 x R.G.B. x 1024	pixel	-
Pixel Pitch	0.279 (H) x 0.279 (V)	mm	-
Pixel Arrangement	RGB vertical stripe	-	-
Display Colors	16M	color	-
Display Operation Mode	Transmissive mode / Normally black	-	-
Surface Treatment	Hard coating (3H), Anti-glare (Haze 25)	-	-

1.5 MECHANICAL SPECIFICATIONS

Item	Min.	Typ.	Max.	Unit	Note	
Module Size	Horizontal(H)	410.2	410.7	411.2	mm	(1), (2)
	Vertical(V)	320.7	321.2	321.7	mm	
	Depth(D)	-	20.2	21.2	mm	
Weight	-	2500		g	-	

Note (1) Please refer to the attached drawings for more information of front and back outline dimensions.

Note (2) Module Depth does not include connectors.

2. ABSOLUTE MAXIMUM RATINGS

2.1 ABSOLUTE RATINGS OF ENVIRONMENT

Item	Symbol	Value		Unit	Note
		Min.	Max.		
Storage Temperature	T _{ST}	-20	+60	°C	(1)
Operating Ambient Temperature	T _{OP}	0	+50	°C	(1), (2)
Shock (Non-Operating)	S _{NOP}	-	120	G	(3), (5)
Vibration (Non-Operating)	V _{NOP}	-	2.0	G	(4), (5)
Altitude (Non-Operation)		0	12,000	M	
Altitude (Operation)		0	5,000	M	

Note (1) Temperature and relative humidity range is shown in the figure below.

(a) 90 %RH Max. ($T_a \leq 40$ °C).

(b) Wet-bulb temperature should be 39 °C Max. ($T_a > 40$ °C).

(c) No condensation.

Note (2) The temperature of panel display surface should be 0 °C Min. and 60 °C Max.

Note (3) 2ms, half sine wave, 1 time for $\pm X$, $\pm Y$, $\pm Z$.

Note (4) 10 ~ 500 Hz, 0.5 Hr, 4 times each X, Y, Z.

Note (5) At testing Vibration and Shock, the fixture in holding the module has to be hard and rigid enough so that the module would not be twisted or bent by the fixture.

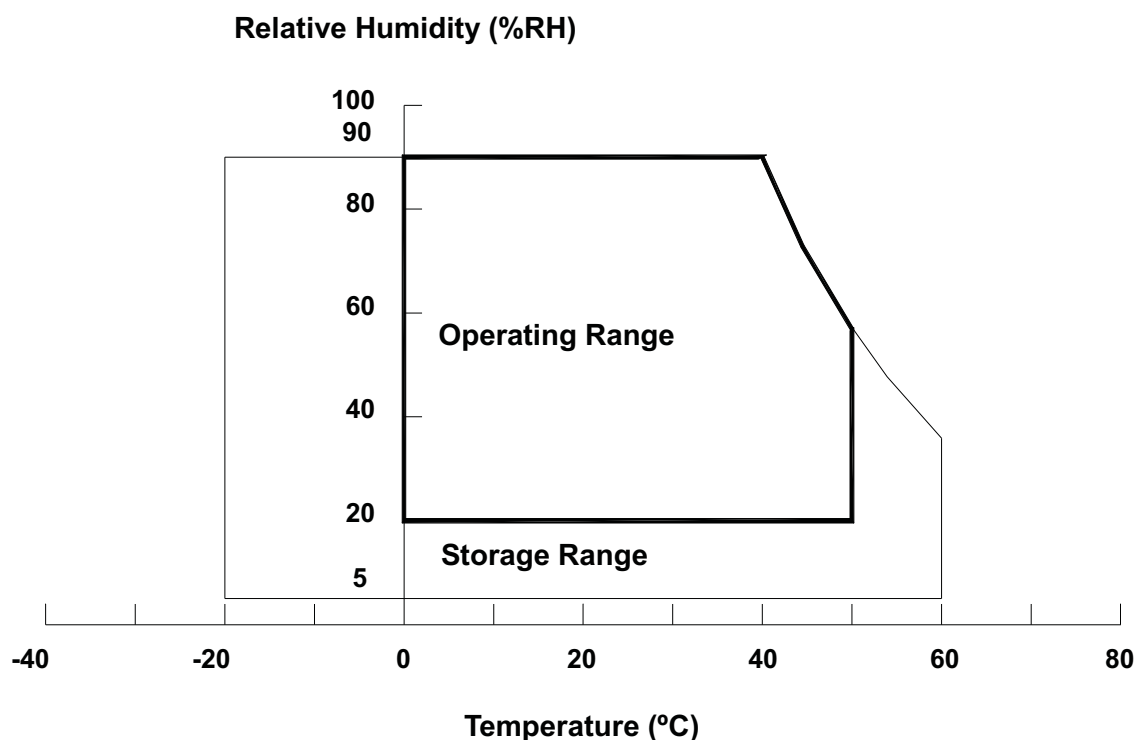

2.2 ELECTRICAL ABSOLUTE RATINGS

2.2.1 TFT LCD MODULE

Item	Symbol	Value		Unit	Note
		Min.	Max.		
Power Supply Voltage	V _{CC}	-0.3	+13.2	V	(1)
Logic Input Voltage	V _{IN}	-0.3	4.3	V	

2.2.2 BACKLIGHT UNIT

Item	Symbol	Value		Unit	Note
		Min.	Max.		
Lamp Voltage	V _L	-	2.5K	V _{RMS}	(1), (2), I _L = 8.0 mA
Lamp Current	I _L	-	9.0	mA _{RMS}	
Lamp Frequency	F _L	-	80	KHZ	(1), (2)

Note (1) Permanent damage to the device may occur if maximum values are exceeded. Function operation should be restricted to the conditions described under Normal Operating Conditions.

Note (2) Specified values are for lamp (Refer to 3.2 for further information).

3. ELECTRICAL CHARACTERISTICS

3.1 TFT LCD MODULE

 $T_a = 25 \pm 2 \text{ } ^\circ\text{C}$

Parameter	Symbol	Value			Unit	Note
		Min.	Typ.	Max.		
Power Supply Voltage	Vcc	11.2	12.0	12.6	V	-
Ripple Voltage	V _{RP}	-	-	240	mV	-
Rush Current	I _{RUSH}	-	-	3.2	A	(2)
Power Supply Current	White	-	580	800	mA	(3)a
	Black	-	390	510	mA	(3)b
	Vertical Stripe	-	500	650	mA	(3)c
LVDS differential input voltage	V _{id}	100	-	600	mV	
LVDS common input voltage	V _{ic}	-	1.2	-	V	
Logic "L" input voltage	V _{il}	V _{ss}	-	0.8	V	

Note (1) The module should be always operated within above ranges.

Note (2) Measurement Conditions:

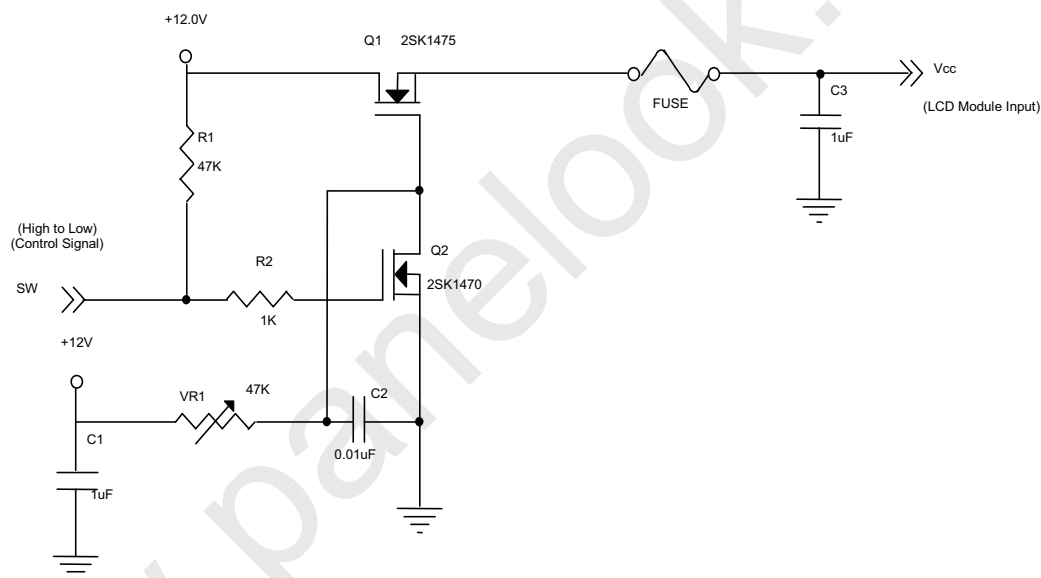

Vcc rising time is 470μs

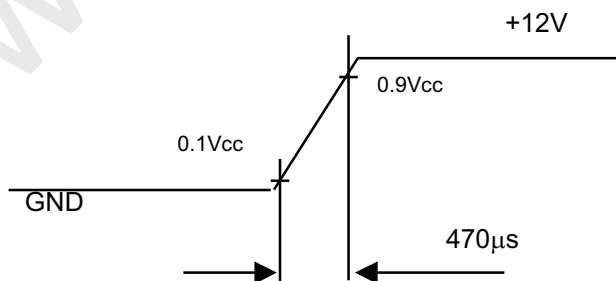

Note (3) The specified power supply current is under the conditions at $V_{CC} = 12\text{ V}$, $T_a = 25 \pm 2\text{ }^\circ\text{C}$, $f_v = 60\text{ Hz}$, whereas a power dissipation check pattern below is displayed.

a. White Pattern

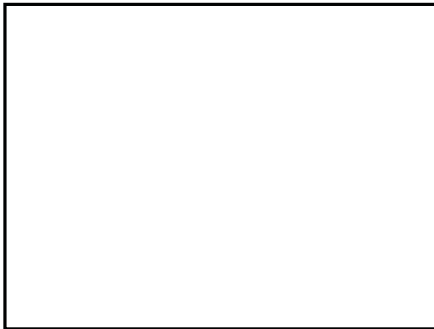

Active Area

b. Black Pattern



Active Area

c. Vertical Stripe Pattern

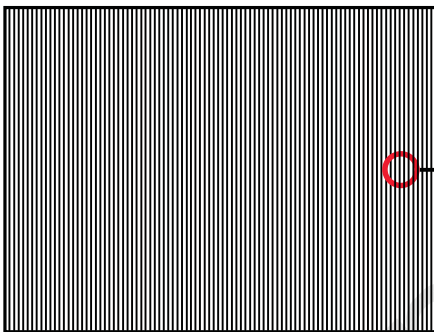

Active Area

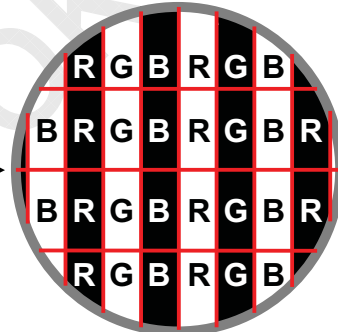

3.2 BACKLIGHT UNIT

 $T_a = 25 \pm 2\text{ }^\circ\text{C}$

Parameter	Symbol	Value			Unit	Note
		Min.	Typ.	Max.		
Lamp Input Voltage	V_L	608	640	672	V_{RMS}	$I_L = 8.0\text{ mA}$
Lamp Current	I_L	3.0	8.0	9.0	mA_{RMS}	(1)
Lamp Turn On Voltage	V_S	-	-	1005 (25 °C)	V_{RMS}	(2)
		-	-	1305 (0 °C)	V_{RMS}	(2)
Operating Frequency	F_L	35	50	80	KHz	(3)
Lamp Life Time	L_{BL}	30,000	36,000	-	Hrs	(5)
Power Consumption	P_L	-	20.5	-	W	(4), $I_L = 8.0\text{ mA}$
Lamp Wire length	L_L	120	125	130	mm	

Note (1) Lamp current is measured by utilizing high frequency current meters as shown below:

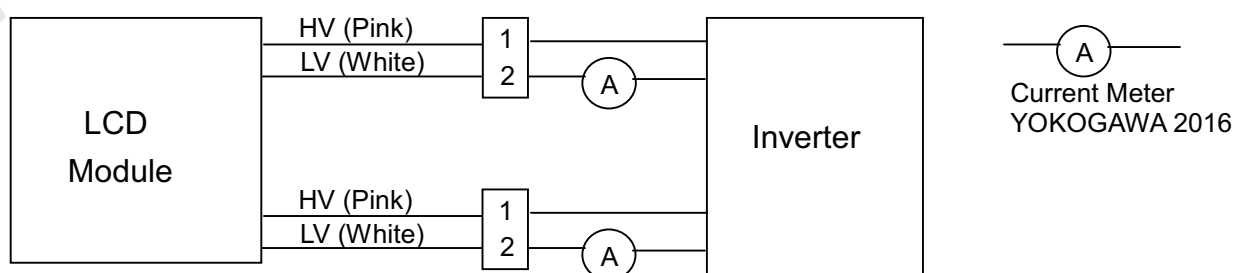

Note (2) The voltage shown above should be applied to the lamp for more than 1 second after startup. Otherwise the lamp may not be turned on.

Note (3) The lamp frequency may produce interference with horizontal synchronous frequency from the display, and this may cause line flow on the display. In order to avoid interference, the lamp frequency should be detached from the horizontal synchronous frequency and its harmonics as far as possible.

Note (4) $P_L = I_L \times V_L$

Note (5) The lifetime of lamp can be defined as the time in which it continues to operate under the condition $T_a = 25 \pm 2 \text{ }^\circ\text{C}$ and $I_L = (3.0) \sim (8.0) \text{ mAmps}$ until one of the following events occurs:

(a) When the brightness becomes or lower than 50% of its original value.

(b) When the effective ignition length becomes or lower than 80% of its original value. (Effective ignition length is defined as an area that has less than 70% brightness compared to the brightness in the center point.)

Note (6) The waveform of the voltage output of inverter must be area-symmetric and the design of the inverter must have specifications for the modularized lamp. The performance of the Backlight, such as lifetime or brightness, is greatly influenced by the characteristics of the DC-AC inverter for the lamp. All the parameters of an inverter should be carefully designed to avoid producing too much current leakage from high voltage output of the inverter. When designing or ordering the inverter please make sure that a poor lighting caused by the mismatch of the Backlight and the inverter (miss-lighting, flicker, etc.) never occurs. If the above situation is confirmed, the module should be operated in the same manners when it is installed in your instrument.

4. BLOCK DIAGRAM

4.1 TFT LCD MODULE

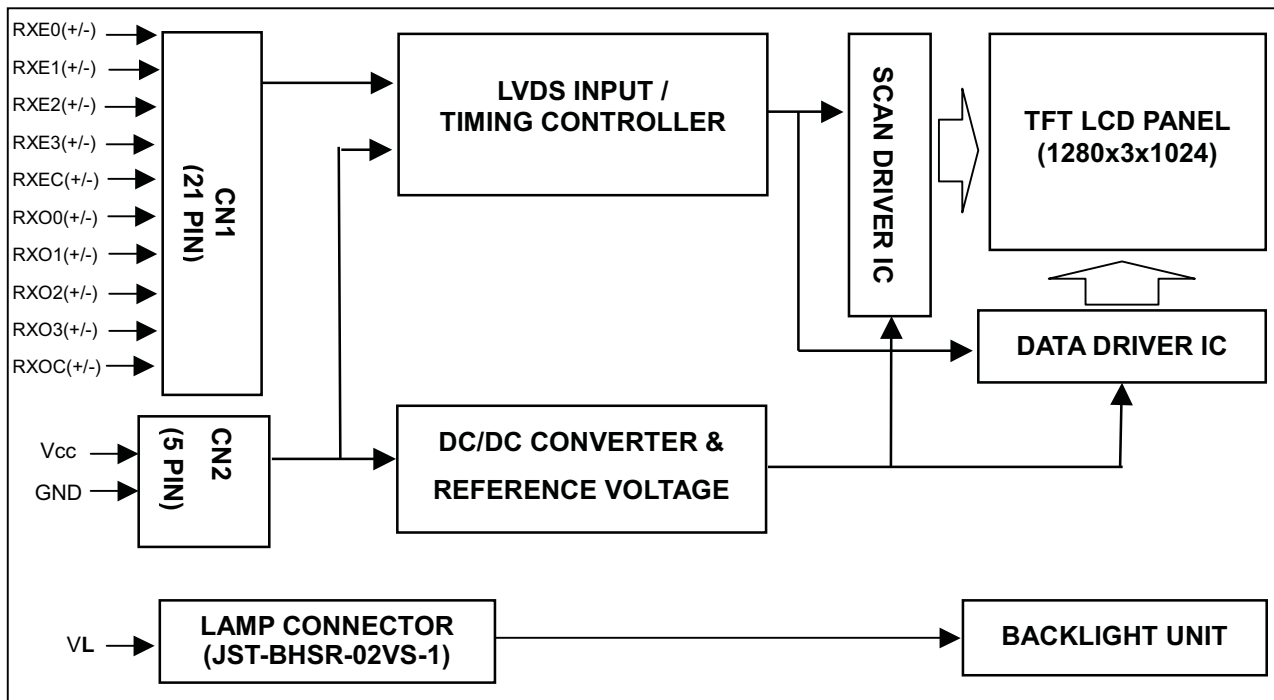

Note (1) Connector(CN1) Part No.: LG CT121-21P-TD, or JAE FI-TWE21PB-VF

Note (1) Connector(CN2) Part No.: JST B5B-ZR-SM3-TF

4.2 BACKLIGHT UNIT

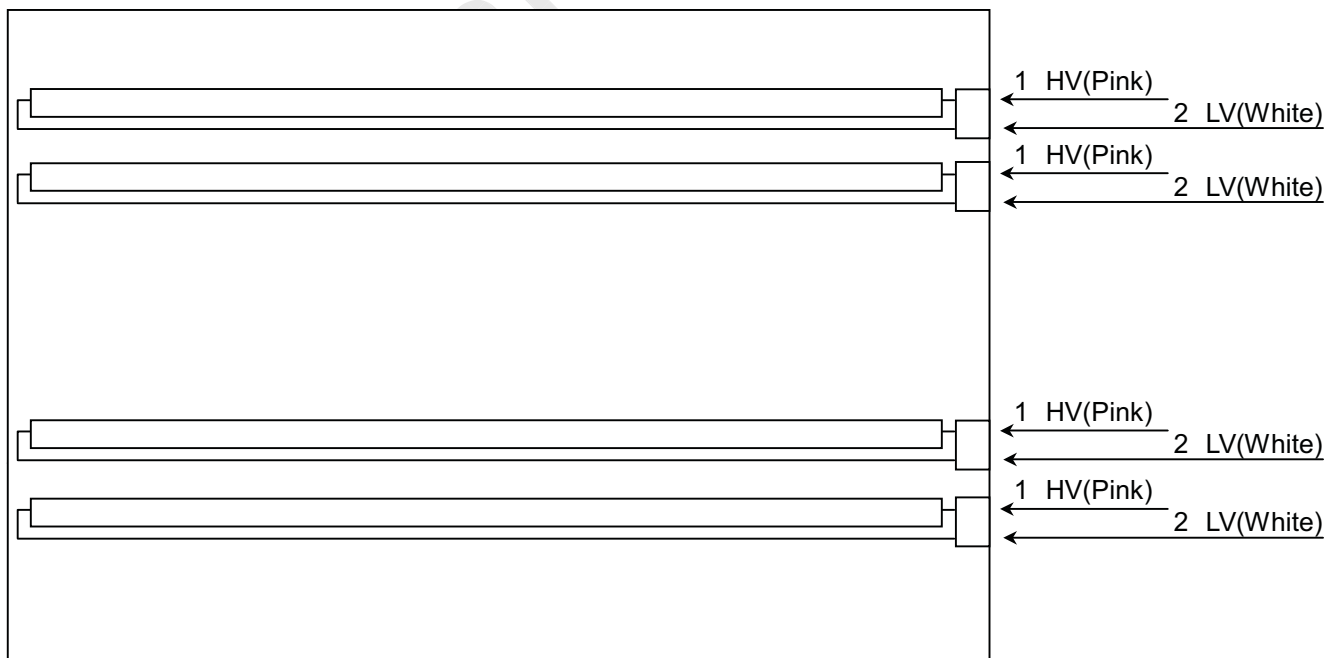

5. INPUT TERMINAL PIN ASSIGNMENT

5.1 TFT LCD MODULE :

Pin	Name	Description	Notes
1	RXE3+	Positive LVDS differential data input. Channel E3 (even)	First Data
2	RXE3-	Negative LVDS differential data input. Channel E3 (even)	
3	RXEC+	Positive LVDS differential clock input. (even)	
4	RXEC-	Negative LVDS differential clock input. (even)	
5	RXE2+	Positive LVDS differential data input. Channel E2 (even)	
6	RXE2-	Negative LVDS differential data input. Channel E2 (even)	
7	RXE1+	Positive LVDS differential data input. Channel E1 (even)	
8	RXE1-	Negative LVDS differential data input. Channel E1 (even)	
9	RXE0+	Positive LVDS differential data input. Channel E0 (even)	
10	RXE0-	Negative LVDS differential data input. Channel E0 (even)	
11	RXO3+	Positive LVDS differential data input. Channel O3 (odd)	Second Data
12	RXO3-	Negative LVDS differential data input. Channel O3(odd)	
13	RXOC+	Positive LVDS differential clock input. (odd)	
14	RXOC-	Negative LVDS differential clock input. (odd)	
15	RXO2+	Positive LVDS differential data input. Channel O2 (odd)	
16	RXO2-	Negative LVDS differential data input. Channel O2 (odd)	
17	RXO1+	Positive LVDS differential data input. Channel O1 (odd)	
18	RXO1-	Negative LVDS differential data input. Channel O1 (odd)	
19	RXO0+	Positive LVDS differential data input. Channel O0 (odd)	
20	RXO0-	Negative LVDS differential data input. Channel O0 (odd)	
21	TEST	Test pin should be tied to ground.	

Note (1) Connector(CN1) Part No.: JAE FI-TWE21PB-VF or equivalent.

Note (2) The first pixel is even.

Note (3) Input signal of even and odd clock should be the same timing.

MODULE POWER CONNECTOR PIN :

Pin	Name	Description	Notes
1	GND	Ground	
2	GND	Ground	
3	GND	Ground	
4	VCC	+12.0 V power supply	
5	VCC	+12.0 V power supply	

Note (1) Connector(CN2) Part No.: JST-B5B-ZR-SM3-TF or equivalent.

LVDS Channel E0	LVDS output	D7	D6	D4	D3	D2	D1	D0
	Data order	EG0	ER5	ER4	ER3	ER2	ER1	ER0
LVDS Channel E1	LVDS output	D18	D15	D14	D13	D12	D9	D8
	Data order	EB1	EB0	EG5	EG4	EG3	EG2	EG1
LVDS Channel E2	LVDS output	D26	D25	D24	D22	D21	D20	D19
	Data order	DE	NA	NA	EB5	EB4	EB3	EB2
LVDS Channel E3	LVDS output	D23	D17	D16	D11	D10	D5	D27
	Data order	NA	EB7	EB6	EG7	EG6	ER7	ER6
LVDS Channel O0	LVDS output	D7	D6	D4	D3	D2	D1	D0
	Data order	OG0	OR5	OR4	OR3	OR2	OR1	OR0
LVDS Channel O1	LVDS output	D18	D15	D14	D13	D12	D9	D8
	Data order	OB1	OB0	OG5	OG4	OG3	OG2	OG1
LVDS Channel O2	LVDS output	D26	D25	D24	D22	D21	D20	D19
	Data order	DE	NA	NA	OB5	OB4	OB3	OB2
LVDS Channel O3	LVDS output	D23	D17	D16	D11	D10	D5	D27
	Data order	NA	OB7	OB6	OG7	OG6	OR7	OR6

5.2 BACKLIGHT UNIT

Pin	Symbol	Description	Color
1	HV	High Voltage	Pink
2	LV	Low Voltage	White
1	HV	High Voltage	Pink
2	LV	Low Voltage	White

Note (1) Connector Part No.: JST-BHSR-02VS-1 or equivalent

Note (2) User's connector Part No.: JST-SM02B-BHSS-1-TB or equivalent

5.3 COLOR DATA INPUT ASSIGNMENT

The brightness of each primary color (red, green and blue) is based on the 8-bit gray scale data input for the color. The higher the binary input, the brighter the color. The table below provides the assignment of color versus data input.

Color		Data Signal																							
		Red								Green								Blue							
		R7	R6	R5	R4	R3	R2	R1	R0	R7	R6	G5	G4	G3	G2	G1	G0	R7	R6	B5	B4	B3	B2	B1	B0
Basic Colors	Black	0	0	0	0	0	0	0	0	0	0	0	0	0	0	0	0	0	0	0	0	0	0	0	0
	Red	1	1	1	1	1	1	1	1	0	0	0	0	0	0	0	0	0	0	0	0	0	0	0	0
	Green	0	0	0	0	0	0	0	0	1	1	1	1	1	1	1	1	0	0	0	0	0	0	0	0
	Blue	0	0	0	0	0	0	0	0	0	0	0	0	0	0	0	0	1	1	1	1	1	1	1	1
	Cyan	0	0	0	0	0	0	0	0	1	1	1	1	1	1	1	1	1	1	1	1	1	1	1	1
	Magenta	1	1	1	1	1	1	1	1	0	0	0	0	0	0	0	0	1	1	1	1	1	1	1	1
	Yellow	1	1	1	1	1	1	1	1	1	1	1	1	1	1	1	1	0	0	0	0	0	0	0	0
	White	1	1	1	1	1	1	1	1	1	1	1	1	1	1	1	1	1	1	1	1	1	1	1	1
Gray Scale Of Red	Red(0) / Dark	0	0	0	0	0	0	0	0	0	0	0	0	0	0	0	0	0	0	0	0	0	0	0	0
	Red(1)	0	0	0	0	0	0	0	1	0	0	0	0	0	0	0	0	0	0	0	0	0	0	0	0
	Red(2)	0	0	0	0	0	0	1	0	0	0	0	0	0	0	0	0	0	0	0	0	0	0	0	0
	⋮	⋮	⋮	⋮	⋮	⋮	⋮	⋮	⋮	⋮	⋮	⋮	⋮	⋮	⋮	⋮	⋮	⋮	⋮	⋮	⋮	⋮	⋮	⋮	⋮
	⋮	⋮	⋮	⋮	⋮	⋮	⋮	⋮	⋮	⋮	⋮	⋮	⋮	⋮	⋮	⋮	⋮	⋮	⋮	⋮	⋮	⋮	⋮	⋮	⋮
	Red(253)	1	1	1	1	1	1	0	1	0	0	0	0	0	0	0	0	0	0	0	0	0	0	0	0
	Red(254)	1	1	1	1	1	1	1	0	0	0	0	0	0	0	0	0	0	0	0	0	0	0	0	0
	Red(255)	1	1	1	1	1	1	1	0	0	0	0	0	0	0	0	0	0	0	0	0	0	0	0	0
Gray Scale Of Green	Green(0) / Dark	0	0	0	0	0	0	0	0	0	0	0	0	0	0	0	0	0	0	0	0	0	0	0	0
	Green(1)	0	0	0	0	0	0	0	0	0	0	0	0	0	0	1	0	0	0	0	0	0	0	0	0
	Green(2)	0	0	0	0	0	0	0	0	0	0	0	0	0	1	0	0	0	0	0	0	0	0	0	0
	⋮	⋮	⋮	⋮	⋮	⋮	⋮	⋮	⋮	⋮	⋮	⋮	⋮	⋮	⋮	⋮	⋮	⋮	⋮	⋮	⋮	⋮	⋮	⋮	⋮
	⋮	⋮	⋮	⋮	⋮	⋮	⋮	⋮	⋮	⋮	⋮	⋮	⋮	⋮	⋮	⋮	⋮	⋮	⋮	⋮	⋮	⋮	⋮	⋮	⋮
	Green(253)	0	0	0	0	0	0	0	1	1	1	1	1	1	1	0	1	0	0	0	0	0	0	0	0
	Green(254)	0	0	0	0	0	0	0	1	1	1	1	1	1	1	0	0	0	0	0	0	0	0	0	0
	Green(255)	0	0	0	0	0	0	0	1	1	1	1	1	1	1	1	0	0	0	0	0	0	0	0	0
Gray Scale Of Blue	Blue(0) / Dark	0	0	0	0	0	0	0	0	0	0	0	0	0	0	0	0	0	0	0	0	0	0	0	0
	Blue(1)	0	0	0	0	0	0	0	0	0	0	0	0	0	0	0	0	0	0	0	0	0	0	0	1
	Blue(2)	0	0	0	0	0	0	0	0	0	0	0	0	0	0	0	0	0	0	0	0	0	0	1	0
	⋮	⋮	⋮	⋮	⋮	⋮	⋮	⋮	⋮	⋮	⋮	⋮	⋮	⋮	⋮	⋮	⋮	⋮	⋮	⋮	⋮	⋮	⋮	⋮	⋮
	⋮	⋮	⋮	⋮	⋮	⋮	⋮	⋮	⋮	⋮	⋮	⋮	⋮	⋮	⋮	⋮	⋮	⋮	⋮	⋮	⋮	⋮	⋮	⋮	⋮
	Blue(253)	0	0	0	0	0	0	0	0	0	0	0	0	0	0	0	1	1	1	1	1	1	1	0	1
	Blue(254)	0	0	0	0	0	0	0	0	0	0	0	0	0	0	0	1	1	1	1	1	1	1	1	0
	Blue(255)	0	0	0	0	0	0	0	0	0	0	0	0	0	0	0	1	1	1	1	1	1	1	1	1

Note (1) 0: Low Level Voltage, 1: High Level Voltage

6. INTERFACE TIMING

6.1 INPUT SIGNAL TIMING SPECIFICATIONS

The input signal timing specifications are shown as the following table and timing diagram.

Signal	Item	Symbol	Min.	Typ.	Max.	Unit	Note
LVDS Clock	Frequency	Fc	31	54	67.5	MHz	-
	Period	Tc	14.8	18.5	32.2	ns	-
	High Time	Tch	-	4/7	-	Tc	-
	Low Time	Tcl	-	3/7	-	Tc	-
LVDS Data	Setup Time	Tlvs	600	-	-	ps	-
	Hold Time	Tlvh	600	-	-	ps	-
Vertical Active Display Term	Frame Rate	Fr	-	-	75	Hz	Tv=Tvd+Tvb
	Total	Tv	1025	1066	1274	Th	-
	Display	Tvd	1024	1024	1024	Th	-
	Blank	Tvb	1	42	250	Th	-
Horizontal Active Display Term	Total	Th	654	844	960	Tc	Th=Thd+Thb
	Display	Thd	640	640	640	Tc	-
	Blank	Thb	14	204	320	Tc	-

Note: Because of this module is operated by DE only mode, Hsync and Vsync input signals should be set to low logic level or ground. Otherwise, this module would operate abnormally.

INPUT SIGNAL TIMING DIAGRAM

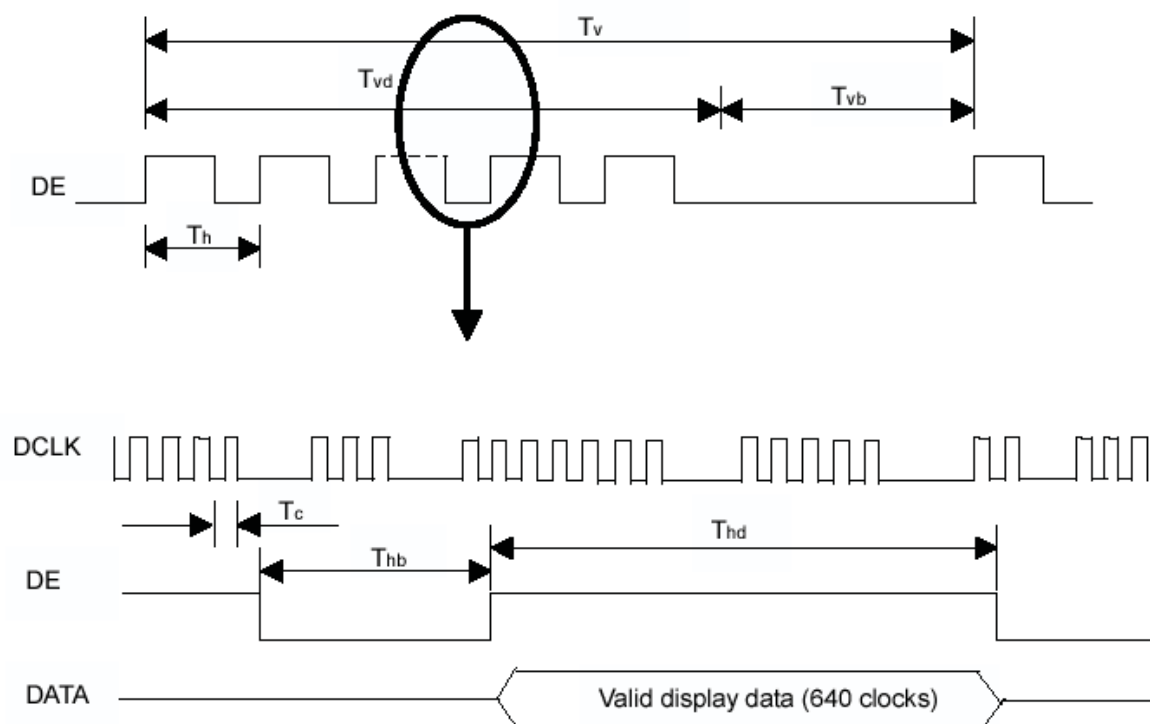

6.2 POWER ON/OFF SEQUENCE

To prevent a latch-up or DC operation of LCD module, the power on/off sequence should be as the diagram below.

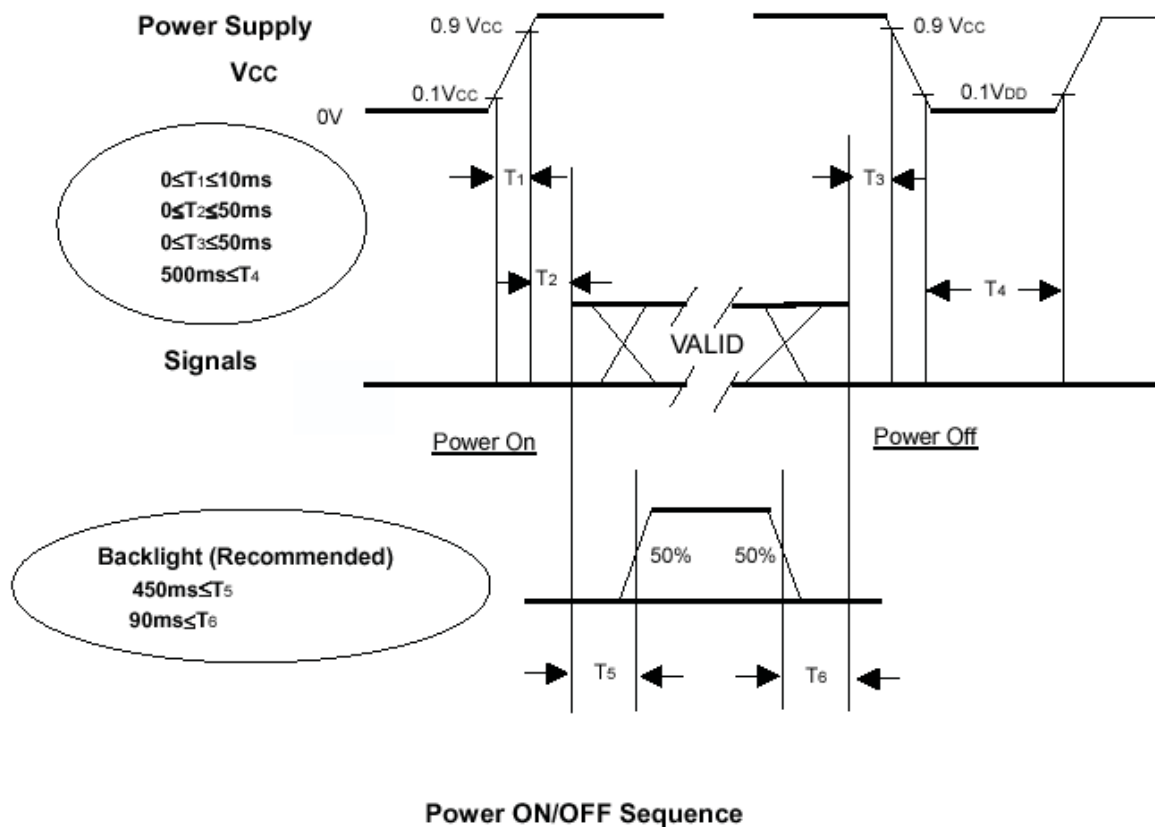

Note.

- (1) The supply voltage of the external system for the module input should be the same as the definition of V_{CC}.
- (2) Apply the lamp voltage within the LCD operation range. When the backlight turns on before the LCD operation of the LCD turns off before the backlight turns off, the display may momentarily become abnormal screen.
- (3) In case of V_{CC} = off level, please keep the level of input signals on the low or keep a high impedance.
- (4) T₄ should be measured after the module has been fully discharged between power of and on period.
- (5) Interface signal shall not be kept at high impedance when the power is on.

7. OPTICAL CHARACTERISTICS

7.1 TEST CONDITIONS

Item	Symbol	Value	Unit
Ambient Temperature	Ta	25±2	°C
Ambient Humidity	Ha	50±10	%RH
Supply Voltage	V _{CC}	12.0	V
Input Signal	According to typical value in "3. ELECTRICAL CHARACTERISTICS"		
Inverter Current	I _L	8.0	mA
Inverter Driving Frequency	F _L	50	KHz
Inverter			

7.2 OPTICAL SPECIFICATIONS

The relative measurement methods of optical characteristics are shown in 7.2. The following items should be measured under the test conditions described in 7.1 and stable environment shown in Note (6).

Item		Symbol	Condition	Min.	Typ.	Max.	Unit	Note
Contrast Ratio		CR	Viewing Normal Angle $\theta_x=0^\circ, \theta_y=0^\circ$	300	400	-	-	(2), (6)
Response Time		T _R		-	20	30	ms	(3)
		T _F		-	10	25	ms	
Center Luminance of White		L _C		200	230	-	cd/m ²	(4), (6)
Average Luminance of White		L _{Ave}		170	200	-	cd/m ²	(4), (6)
White Variation		ΔW		-	1.33	1.45	-	(6), (7)
Cross Talk		CT		-	-	2.5	%	(5), (6)
Color Chromaticity	Red	Rx		0.611	0.631	0.651	-	(1), (6)
		Ry		0.339	0.359	0.379	-	
	Green	Gx		0.281	0.301	0.321	-	
		Gy	0.575	0.595	0.615	-		
	Blue	Bx	0.125	0.145	0.165	-		
		By	0.078	0.098	0.118	-		
	White	Wx	0.290	0.310	0.330	-		
		Wy	0.310	0.330	0.350	-		
Viewing Angle	Horizontal	θ _{x+}	CR≥10	80	-	-	Deg.	
		θ _{x-}		80	-	-		
	Vertical	θ _{y+}		80	-	-		
		θ _{y-}		80	-	-		

Note (1) Definition of Viewing Angle (θ_x , θ_y):

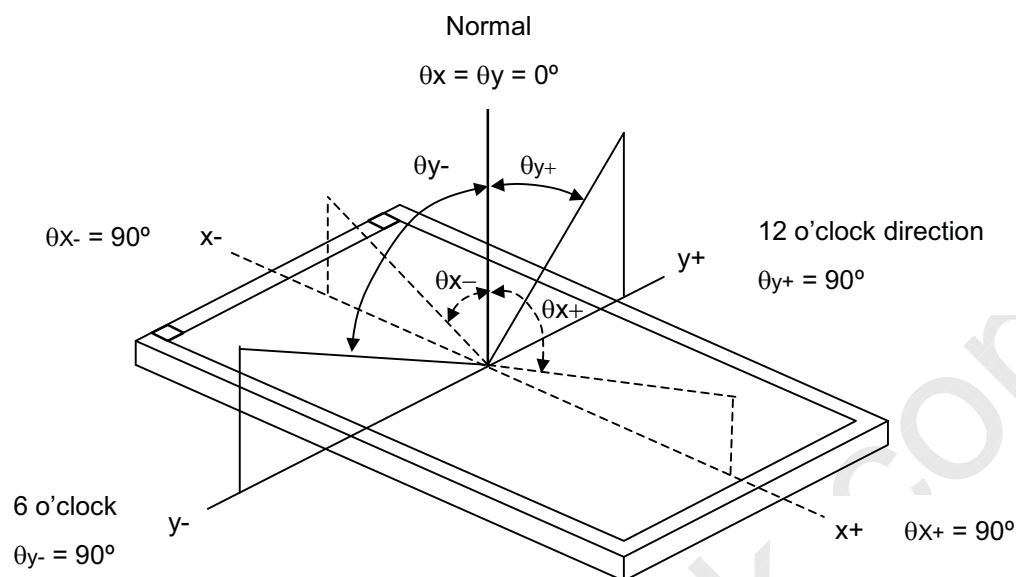

Note (2) Definition of Contrast Ratio (CR):

The contrast ratio can be calculated by the following expression.

$$\text{Contrast Ratio (CR)} = L_{255} / L_0$$

L255: Luminance of gray level 255

L 0: Luminance of gray level 0

$$\text{CR} = \text{CR} (5)$$

CR (X) is corresponding to the Contrast Ratio of the point X at Figure in Note (7).

Note (3) Definition of Response Time (T_R , T_F):

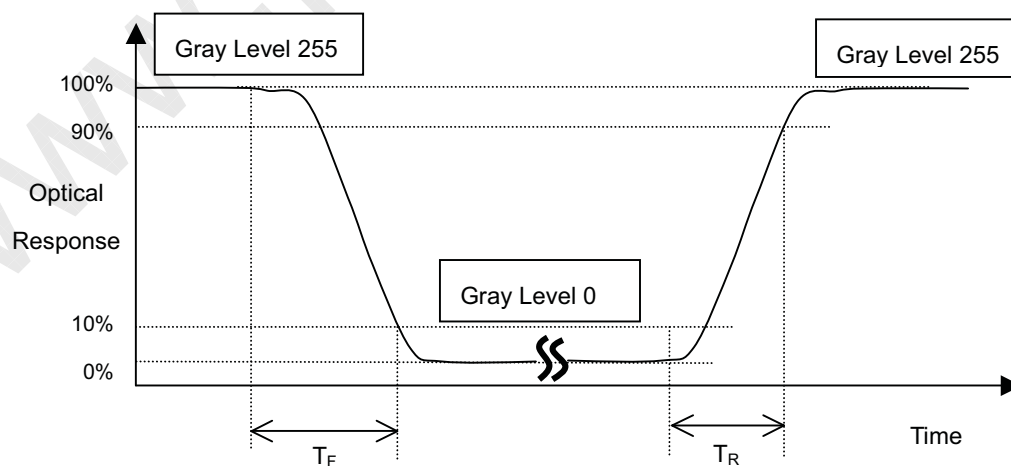

Note (4) Definition of Luminance of White (L_C , L_{AVE}):

Measure the luminance of gray level 255 at center point and 9 points

$$L_C = L(5)$$

$$L_{AVE} = [\text{Minimum } [L(1), L(2), L(3), L(4), L(5), L(6), L(7), L(8), L(9)]] / 9$$

$L(x)$ is corresponding to the luminance of the point X at Figure in Note (7).

Note (5) Definition of Cross Talk (CT):

$$CT = |Y_A - Y_B| / Y_B \times 100 (\%)$$

Where:

Y_A = Luminance of measured location without gray level 0 pattern (cd/m^2)

Y_B = Luminance of measured location with gray level 0 pattern (cd/m^2)

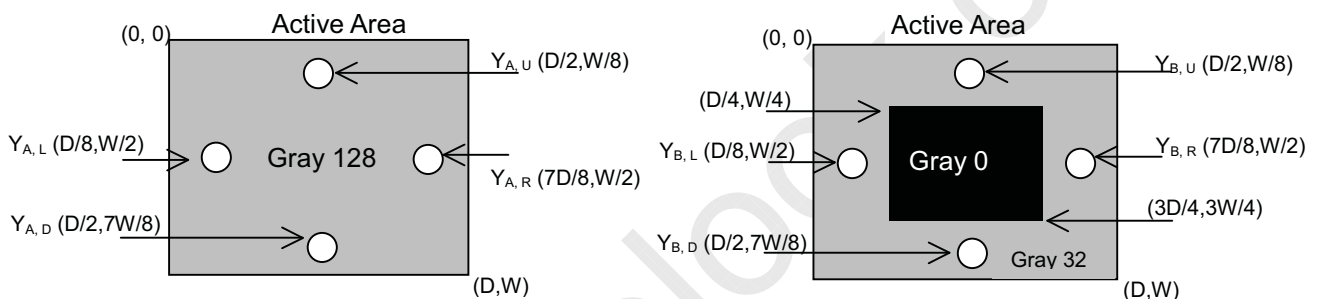

Note (6) Measurement Setup:

The LCD module should be stabilized at given temperature for 20 minutes to avoid abrupt temperature change during measuring. In order to stabilize the luminance, the measurement should be executed after lighting Backlight for 20 minutes in a windless room.

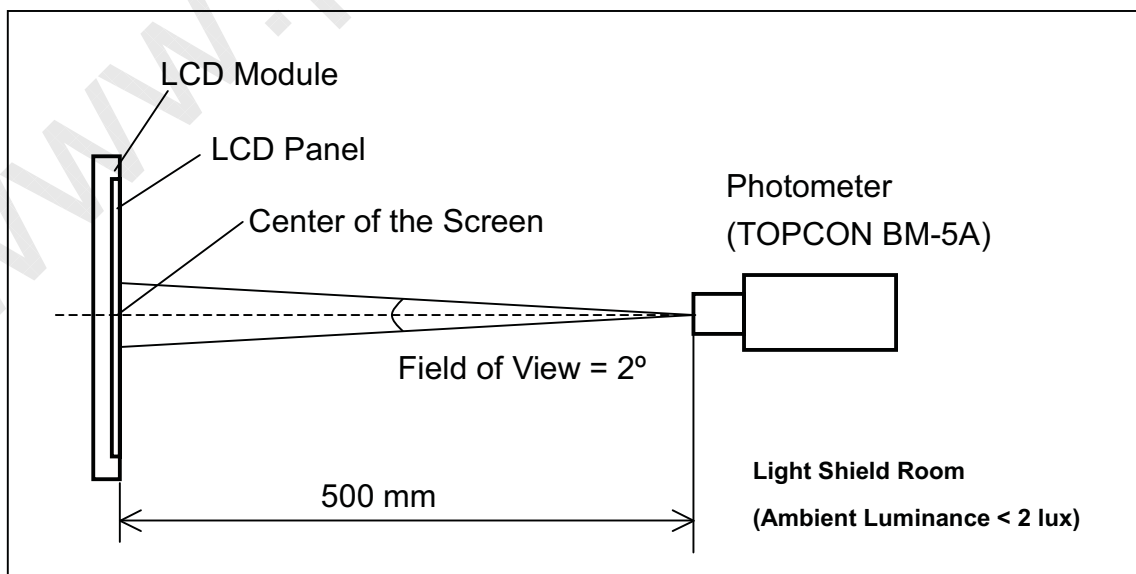

Note (7) Definition of White Variation (δW):

Measure the luminance of gray level 255 at 9 points

$$\delta W = \frac{\text{Maximum [L (1), L (2), L (3), L (4), L (5), L (6), L (7), L (8), L (9)]}}{\text{Minimum [L (1), L (2), L (3), L (4), L (5), L (6), L (7), L (8), L (9)]}}$$

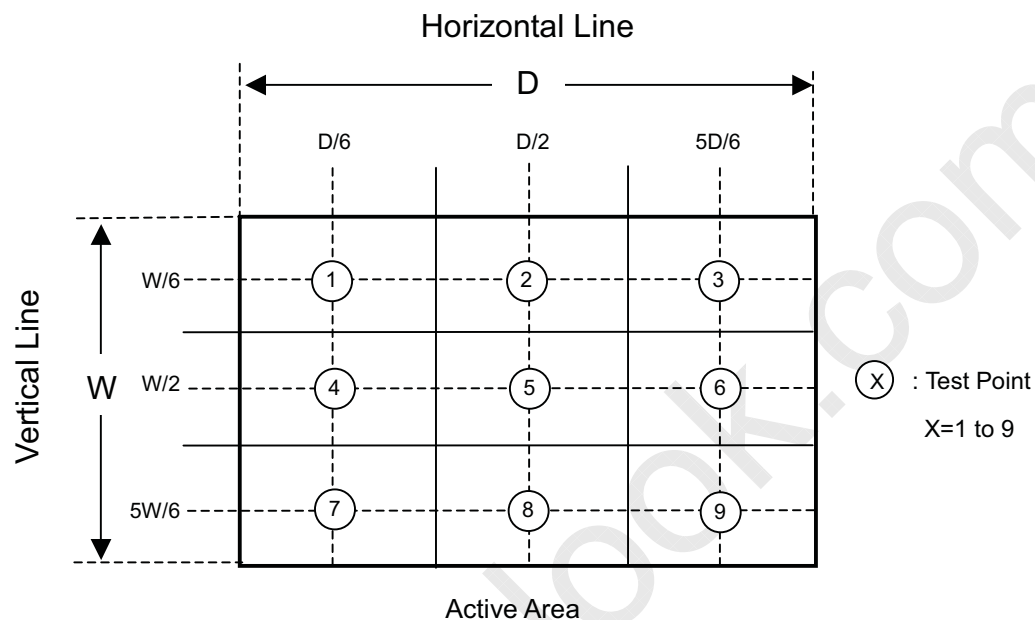

8. PRECAUTIONS

8.1 ASSEMBLY AND HANDLING PRECAUTIONS

- (1) Do not apply rough force such as bending or twisting to the module during assembly.
- (2) To assemble or install module into user's system can be only in clean working areas. The dust and oil may cause electrical short or worsen the polarizer.
- (3) It's not permitted to have pressure or impulse on the module because the LCD panel and Backlight will be damaged.
- (4) Always follow the correct power sequence when LCD module is connecting and operating. This can prevent damage to the CMOS LSI chips during latch-up.
- (5) Do not pull the I/F connector in or out while the module is operating.
- (6) Do not disassemble the module.
- (7) Use a soft dry cloth without chemicals for cleaning, because the surface of polarizer is very soft and easily scratched.
- (8) It is dangerous that moisture come into or contacted the LCD module, because moisture may damage LCD module when it is operating.
- (9) High temperature or humidity may reduce the performance of module. Please store LCD module within the specified storage conditions.
- (10) When ambient temperature is lower than 10°C may reduce the display quality. For example, the response time will become slowly, and the starting voltage of CCFL will be higher than room temperature.

8.2 SAFETY PRECAUTIONS

- (1) The startup voltage of Backlight is approximately 1000 Volts. It may cause electrical shock while assembling with inverter. Do not disassemble the module or insert anything into the Backlight unit.
- (2) If the liquid crystal material leaks from the panel, it should be kept away from the eyes or mouth. In case of contact with hands, skin or clothes, it has to be washed away thoroughly with soap.
- (3) After the module's end of life, it is not harmful in case of normal operation and storage.

9. PACKAGING

9.1 PACKING SPECIFICATIONS

- (1) 5 LCD modules / 1 Box
- (2) Box dimensions : 534(L) X 316(W) X 462(H) mm
- (3) Weight : approximately 13.5Kg (5 modules per box)

9.2 PACKING Method

Figures 9-1 and 9-2 are the packing method.

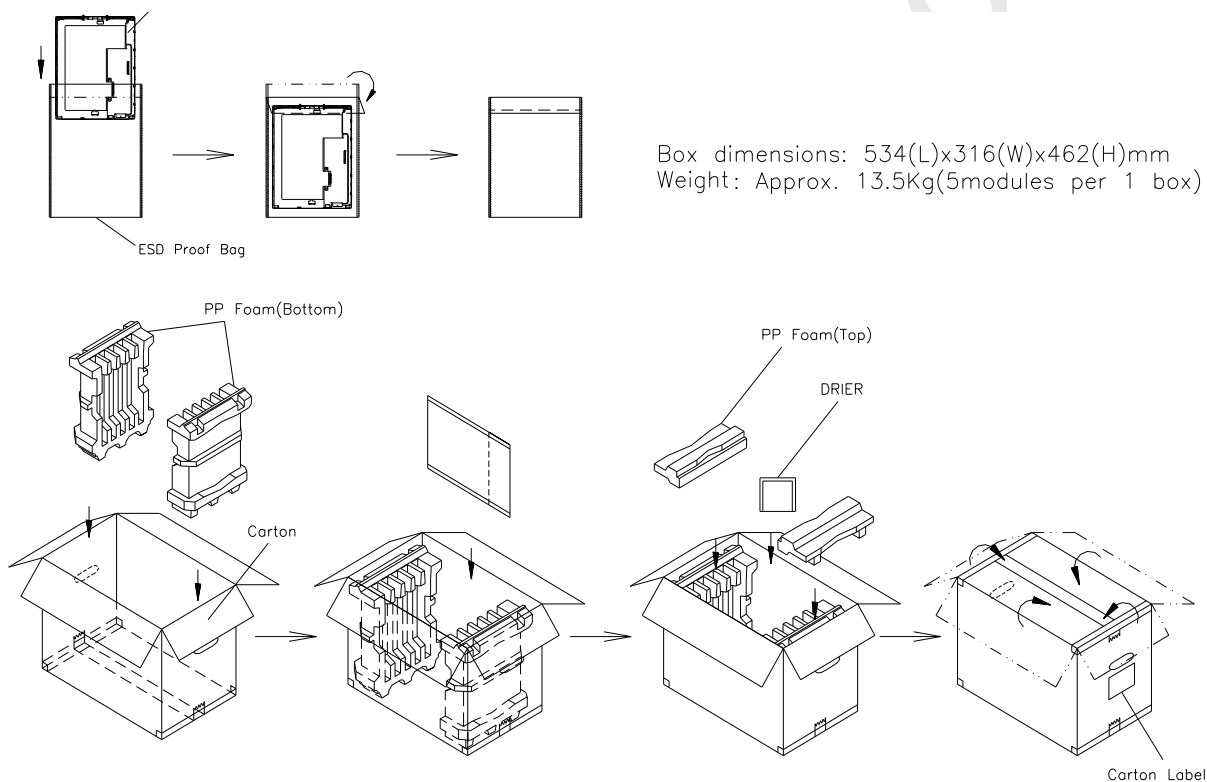
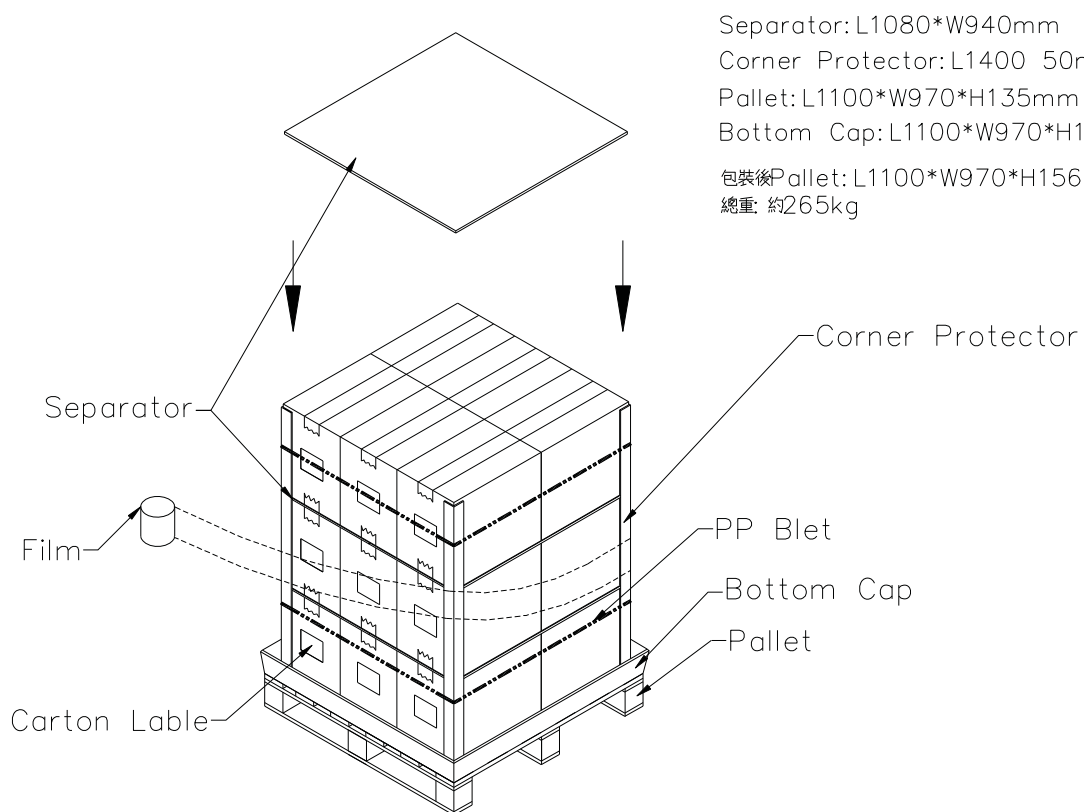

Figure. 9-1 Packing method

Figure. 9-2 Packing method

10. INCOMING INSPECTION DAY

The Supplier should be acquainted the inspection results (acceptance or rejection) by Customer, and the results are in accordance with the incoming inspection standard within 30 days after the date of the bills of lading.

Should Customer fail to so notify the Supplier within the said 30 days period. The Customer's right to reject the LCMS shall then lapse, and the said LCMS shall be deemed to have been accepted by the customer.

11. DEFINITION OF SHIPPING LABEL ON MODULE

The barcode nameplate is pasted on each module as illustration, and its definition is as following explanation.

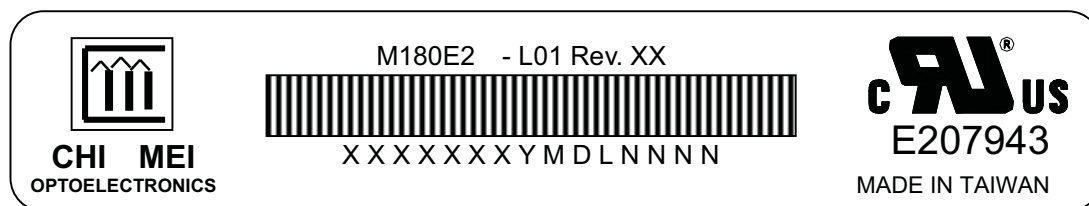

(1) Model Name: M180E2 - L01

(2) Revision: Rev. XX, for example: C1, C2 ...etc.

(3) Serial ID: XXXXXXXXYMDLNNNN

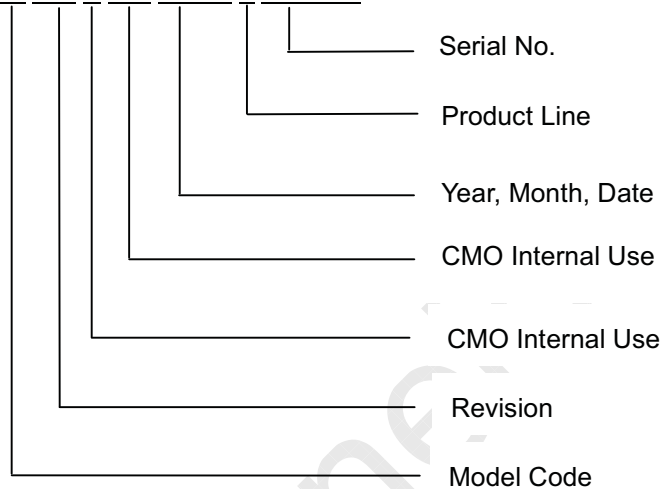

Serial ID included the information as follow:

1. Manufactured Date: Year: 0~9, for 2000~2009
 Month: 1~9, A~C, for Jan. ~ Dec.
 Day: 1~9, A~Y, for 1st to 31st, exclude I, O and U
2. Revision Code: cover all the change
3. Model code
4. Serial No.: Manufacturing sequence of product

12. RELIABILITY ENVIRONMENT TEST CONDITION

No.	Test Item	Test Condition	Note
1.	High temperature storage test	60°C, 240H	
2.	Low temperature storage test	-20°C, 240H	
3.	High temperature operation test	50°C, 240H	
4.	Low temperature operation test	0°C, 240H	
5.	High temp./humi. operation test	40°C / 90%RH, 240H	
6.	Vibration test (Non-operation)	2.0G, 10 Hz ~ 500 Hz, sweep sine wave for 1 cycle in 30 minutes. 4 cycles for each X, Y, Z axis.	
7.	Mechanical shock test (Non-operation)	Half sine wave, 120G / 2ms for ± X, ± Y, ± Z. one time shock for each direction.	
8.	Altitude (Non-operation)	12000M, 24H	
9.	Altitude (Operation)	5000M, 24H	
10.	ESD (Non-operation)	150pF, 330Ω Contact mode : 10 KV Air mode : 10 KV	

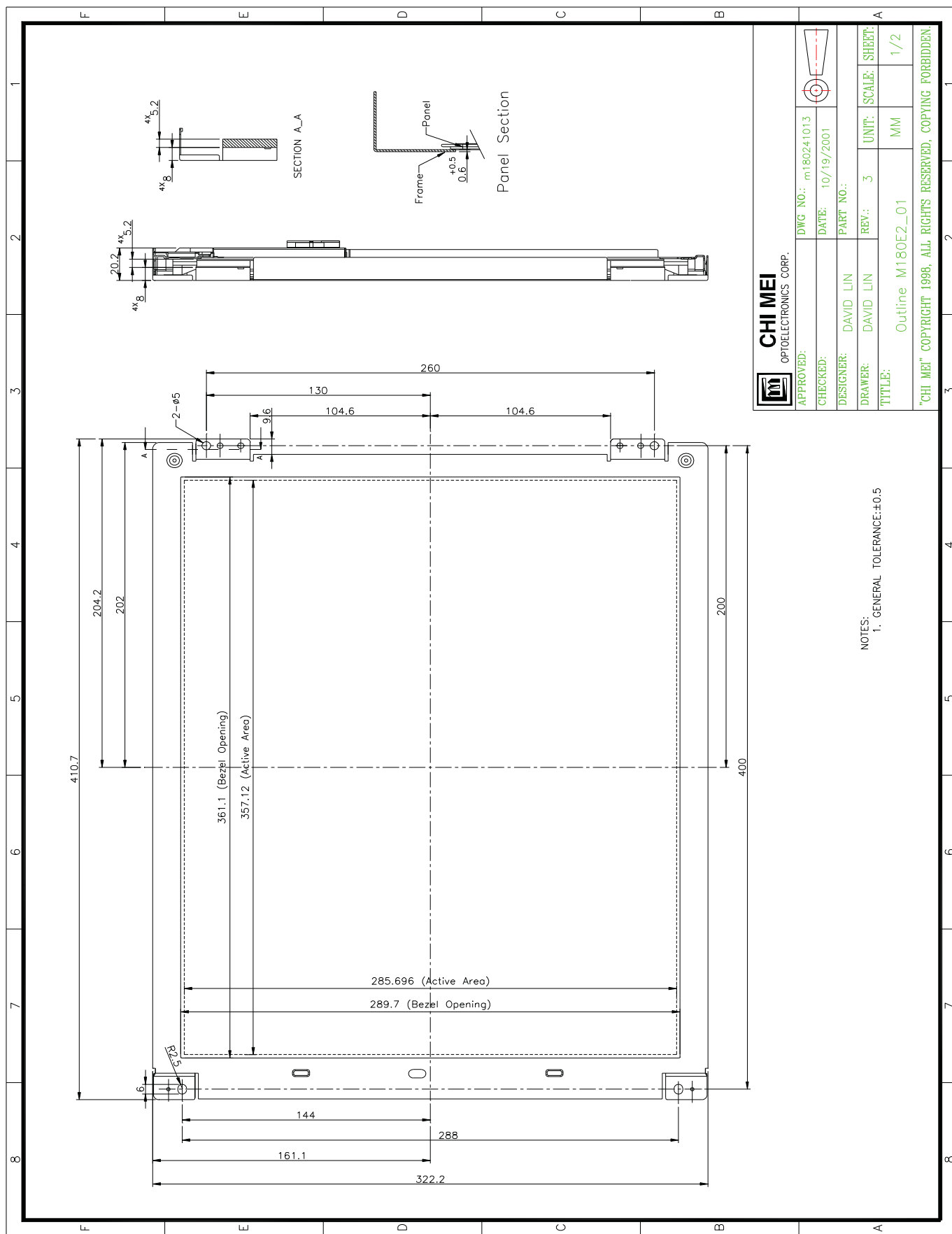

CHI MEI OPTOELECTRONICS CORP.		DWG NO.: m180241013	DATE: 10/19/2001	PART NO.:
APPROVED:	CHECKED:	DESIGNER: DAVID LIN	DRAWER: DAVID LIN	REV.: 3
TITLE: Outline M180E2_01		UNIT: MM	SCALE: 1/2	SHEET: 1/2
NOTES: 1. GENERAL TOLERANCE:±0.5				
"CHI MEI" COPYRIGHT 1998, ALL RIGHTS RESERVED, COPYING FORBIDDEN.				

