

TFT LCD Approval Specification

CMO MODEL NO.: M185B1-C01

Customer: _____

Approved by: _____

Note:

核准時間	部門	審核	角色	投票
2009-10-01 10:18:03	MTR 產品管理處		Director	Accept

- CONTENTS -

. REVISION HISTORY	-----	3
1. GENERAL DESCRIPTION	-----	4
1.1 OVERVIEW		
1.2 FEATURES		
1.3 APPLICATION		
1.4 GENERAL SPECIFICATIONS		
2. ABSOLUTE MAXIMUM RATINGS	-----	4
3. SUGGESTIVE DRIVING CONDITION	-----	5
4. PANEL PIN DEFINITION	-----	6
5. OPTICAL CHARACTERISTICS	-----	9
5.1 TEST CONDITIONS		
5.2 OPTICAL SPECIFICATIONS		
6. PACKAGING	-----	13
6.1 PACKING SPECIFICATIONS		
6.2 PACKING METHOD		
7. DEFINITION OF LABELS	-----	15
8. PRECAUTIONS	-----	16
8.1 ASSEMBLY AND HANDLING PRECAUTIONS		
8.2 SAFETY PRECAUTIONS		
9. RELIABILITY TEST	-----	17
10. PANEL DRAWING	-----	17

REVISION HISTORY

Version	Date	Section	Description
Ver. 1.0	May, 30 '08	-	M185B1-C01 Approval specifications was first issued .
Ver. 2.0	Jul, 29 '08	1.4	Modify Max Weight from 410g to 400g
		6.1-2	Revise the characters "Carton dimension" to "Dense box dimension"
		6.1-3	Revise the characters "(50 cells per carton)" to "(50 cells per Bag)"
Ver. 2.1	Jun, 02 '09	6.1	Revise the "PACKING SPECIFICATION"
		6.2	Revise the "PACKING METHOD"
Ver. 2.2	Sep, 10 '09	4.1	Modify the TAB_1's Pin number.27,28 from Vcom to GND
			Modify the TAB_6's Pin number.754,755 from Vcom to GND
		8	Adding chapter 9 RELIABILITY TEST

1. GENERAL DESCRIPTION

1.1 OVERVIEW

The M185B1-C01 is a 18.5-inch wide LCD cell with thin film transistors as active elements and contains 1366x768 pixels . Each pixel is divided into red, green and blue dot, which are arranged in vertical stripe. The cell is normally white mode, and can be applied to the transmission type display. Backlight unit (BLU) and circuit board for the cell are not built in.

1.2 FEATURES

- Wide viewing angle
- High contrast ratio
- Fast response time
- WXGA (1366 x 768 pixels) resolution

1.3 APPLICATION

- LCD Monitor
- LCD TV

1.4 GENERAL SPECIFICATIONS

Item	Specification	Unit
Max Panel Dimension (TFT)	420.65 X 241.25	mm
Glass thickness(TFT/ CF)	0.7/ 0.7	mm
Active Area	409.8 (H) x 230.4 (V) (18.5" diagonal)	mm
Driver Element	a-si TFT active matrix	-
Pixel Number	1366X R.G.B X 768	pixel
Pixel Pitch	0.3 (H) X 0.3 (V)	mm
Pixel Arrangement	RGB vertical stripe	-
Transmissive Mode	Normally white	-
Surface Treatment	Hard coating (3H), AG (Haze 25%)	-
Polarizer Type	E -Wide View	-
Polarizer Dimension	TFT	417.15 X 237.8
	CF	417.15 X 237.8
Polarizer Thickness	TFT	0.215
	CF	0.215
Weight	400 (Max.)	g

2. ABSOLUTE MAXIMUM RATINGS

1. Storage condition: With shipping package.
2. Storage temperature range: 25±5 °C.
3. Storage humidity range: 50±10% RH.
4. Shelf life: 30 days

3. Suggestive Driving Condition

Item		Min.	Typ.	Max.	Unit		
Driving Voltage	V_G	On	23.17	24.43	-	V	
		Off	-	-6.846	-6.66	V	
	V_D	B	Gam1	-	12.242	-	V
			Gam14	-	0.291	-	V
		W	Gam7	-	6.698	-	V
			Gam8	-	5.988	-	V
	V_{COM}	Center	-	5.6	-	V	
G ↓ -D offset		2	-	-	us		
Charging time		-	9.28	-	us		

B: Black pattern

W: White pattern

Gamma Voltage : Gam1 > Gam2 > Gam3 > ... > Gam14 G ↓ : gate pulse falling edge

DRIVING TIMING DIAGRAM

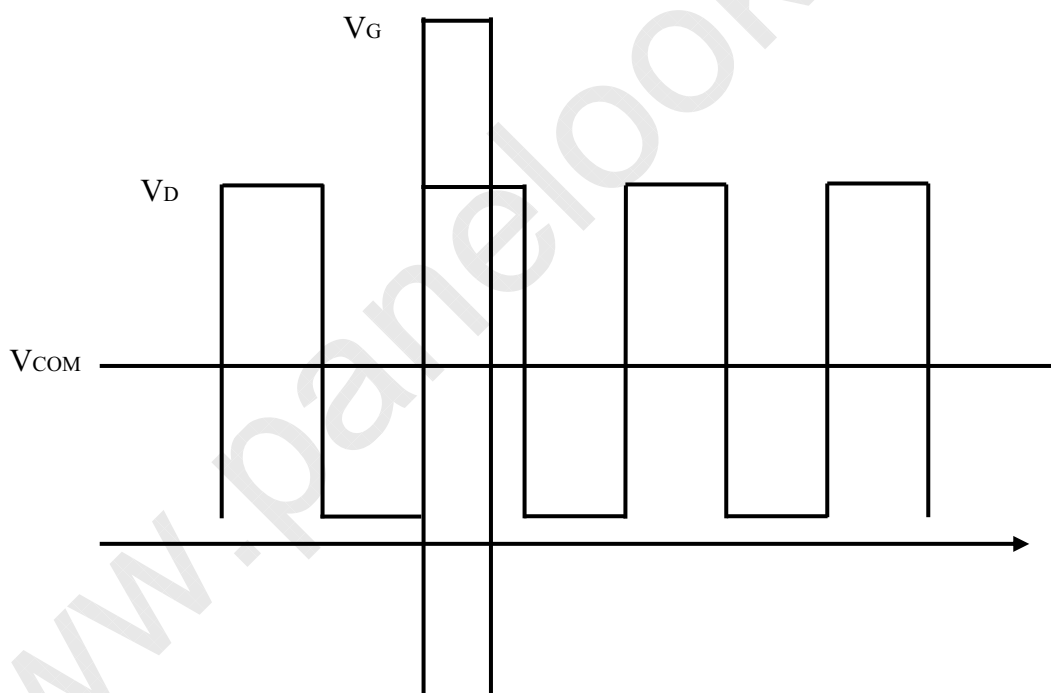

4. PANEL PIN DEFINITION

4.1 DATA PIN DEFINE

Pin number	TAB_1	TAB_2~5	TAB_6
1	dummy	dummy	dummy
2	dummy	dummy	dummy
3	dummy	dummy	dummy
4	Test	Test	Test
5	Test	Test	Test
6	dummy	dummy	dummy
7	dummy	dummy	dummy
8	LR	dummy	dummy
9	XAO	dummy	dummy
10	OE	dummy	dummy
11	CPV	dummy	dummy
12	STV1	dummy	dummy
13	STV2	dummy	dummy
14	VSS	dummy	dummy
15	VSS	dummy	dummy
16	VDD	dummy	dummy
17	VDD	dummy	dummy
18	Vee	dummy	dummy
19	Vgl	dummy	dummy
20	Vgl	dummy	dummy
21	Vgl	dummy	dummy
22	dummy	dummy	dummy
23	Vgh	dummy	dummy
24	Vgh	dummy	dummy
25	Vgh	dummy	dummy
26	Vcom	Vcom	Vcom
27	GND	dummy	dummy
28	GND	dummy	dummy
29	Vcom	Vcom	Vcom
30	Test	Test	Test
31	OUT_1	OUT_1	OUT_1
32	OUT_2	OUT_2	OUT_2
33	OUT_3	OUT_3	OUT_3

34	OUT_4	OUT_4	OUT_4
35	OUT_5	OUT_5	OUT_5
36	OUT_6	OUT_6	OUT_6
37	OUT_7	OUT_7	OUT_7
38	OUT_8	OUT_8	OUT_8
39	OUT_9	OUT_9	OUT_9
....
372	OUT_342	OUT_342	OUT_342
373	OUT_343(NC)	OUT_343(NC)	OUT_343(NC)
'...	'----	'----	'----
408	OUT_378(NC)	OUT_378(NC)	OUT_378(NC)
409	OUT_379	OUT_379	OUT_379
....
744	OUT_714	OUT_714	OUT_714
745	OUT_715	OUT_715	OUT_715(NC)
....	----	----	----
750	OUT_720	OUT_720	OUT_720(NC)
751	Test	Test	Test
752	dummy	dummy	Test
753	Vcom	Vcom	Vcom
754	dummy	dummy	GND
755	dummy	dummy	GND
756	dummy	dummy	Vgl
757	dummy	dummy	Vcom
758	dummy	dummy	Vcom
759	dummy	dummy	dummy
760	dummy	dummy	Test
761	Vcom	Vcom	Vcom
762	Vcom	Vcom	Vcom
763	Test	Test	Test
764	Test	Test	Test
765	dummy	dummy	dummy
766	dummy	dummy	dummy
767	dummy	dummy	dummy

Note: 1. Dummy pin is recommend for floating

2. LR default value is Vss (ground)



Approval

4.2 SCAN PIN DEFINE

Scan_1~3	DUMMY	OE	CPV	PASS2	STV2	VSS	MODE2	VDD	VEE	VEE
XAO	155	156	157	157	159	160	161	162	163	164
VDD	154								165	166
LR	153								167	168
PASS3	152								169	170
	151								171	172
									173	174
									175	176
DUMMY	150								177	178
.										179
.										180
.										181
.										182
.										183
DUMMY	15								184	185
PASS3	14								439	440
LR	13								441	442
VSS	12								443	444
XAO	11								445	446
	10								447	448
	9								449	450
	8								451	452
	7								453	454
	6								455	456
	5								457	458
	4								459	460
	3								461	462
	2								463	464
	1								465	466
	DUMMY									
	OE									
	CPV									
	PASS2									
	STV1									
	VSS									
	MODE1									
	VDD									
	VEE									
	VEE									

5. OPTICAL CHARACTERISTICS

5.1 TEST CONDITIONS

Item	Symbol	Value	Unit
Ambient Temperature	Ta	25±2	°C
Ambient Humidity	Ha	50±10	%RH
Gamma voltage	-	Refer to Item 3 driving condition	V
Vcom	-	most suitable Vcom	V

5.2 OPTICAL SPECIFICATION

ITEM		Symbol	Condition	MIN.	TYP.	MAX.	UNIT	NOTE
Contrast Ratio		CR	$\theta_x=\theta_y=0^\circ$ CS-1000T	630	1000	-	%	3,1
Response Time (Black/White)		Tr	$\theta_x=\theta_y=0^\circ$	---	1.5	3.5	ms	4
		Tf	$\theta_x=\theta_y=0^\circ$	---	3.5	6.5	ms	4
Center point Transmittance		T%	$\theta_x=\theta_y=0^\circ$ CS-1000T	5.4	6.0	-	%	8,1,5
Transmittance uniformity (9pts)		$\Delta T\%$	$\theta_x=\theta_y=0^\circ$	-	1.3	1.42	-	7,1
Viewing Angle	Horizontal θ_x ($\theta_y=0^\circ$)	Right	CR ≥ 10 USB-2000	75	85	-	Deg	2,6,1
		Left		75	85	-	Deg	
	Vertical θ_y ($\theta_x=0^\circ$)	Up		70	80	-	Deg	
		Down		70	80	-	Deg	
Color Coordinate at center point	Red	Rcx	$\theta_x=\theta_y=0^\circ$	Typ -0.03	0.652	Typ +0.03	-	6,0
		Rcy	$\theta_x=\theta_y=0^\circ$		0.330		-	
	Green	Gcx	$\theta_x=\theta_y=0^\circ$		0.275		-	
		Gcy	$\theta_x=\theta_y=0^\circ$		0.590		-	
	Blue	Bcx	$\theta_x=\theta_y=0^\circ$		0.148		-	
		Bcy	$\theta_x=\theta_y=0^\circ$		0.107		-	
	White	Wcx	$\theta_x=\theta_y=0^\circ$		0.320		-	
		Wcy	$\theta_x=\theta_y=0^\circ$		0.360		-	

Note (0) Light source is the standard light source "C" which is defined by CIE and driving voltages are based on suitable gamma voltages. The calculating method is as following :

1. Measure Module's and BLU's spectrums. White is without signal input and R, G, B are with signal input. BLU (for M185B1-L01) is supplied by CMO.
2. Calculate cell's spectrum.
3. Calculate cell's chromaticity by using the spectrum of standard light source "C".

Note (1) Light source is the BLU, which is supplied by CMO, and driving voltages are based on suitable gamma voltages. White is without signal input and R, G, B are with signal input. SPEC is judged by CMO's golden sample.

Note (2) Definition of Viewing Angle (θ_x , θ_y):

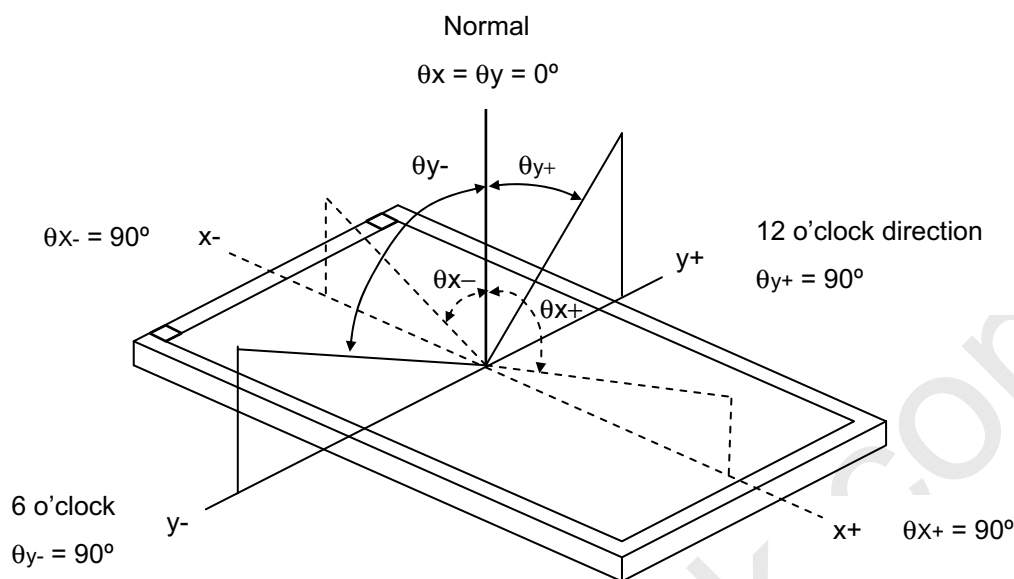

Note (3) Definition of Contrast Ratio (CR):

The contrast ratio can be calculated by the following expression.

$$\text{Contrast Ratio (CR)} = L_{255} / L_0$$

L255: Luminance of gray level 255

L 0: Luminance of gray level 0

$$\text{CR} = \text{CR} (5)$$

CR (X) is corresponding to the Contrast Ratio of the point X at Figure in Note (7).

Note (4) Definition of Response Time (T_R , T_F):

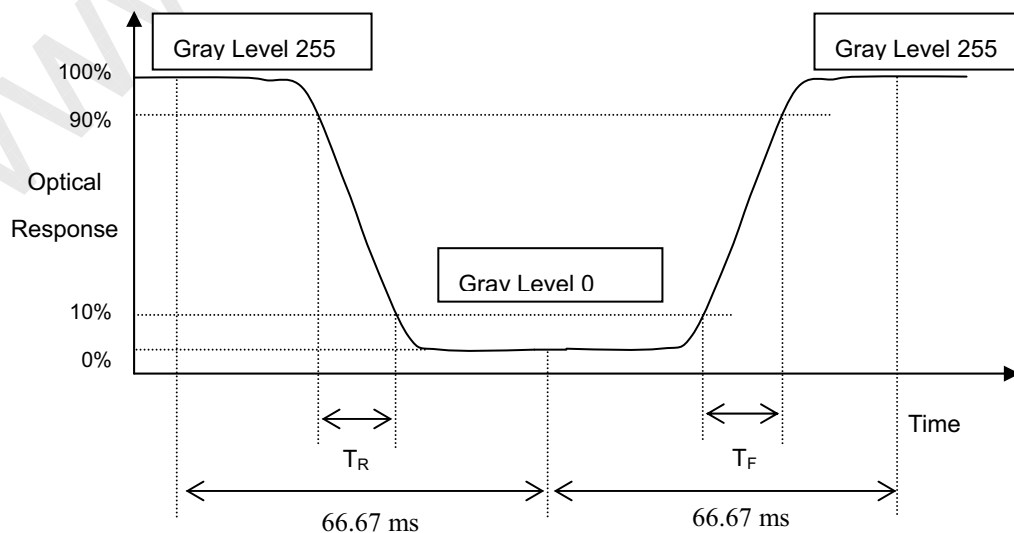

Note (5) Definition of Luminance of White (L_c):

Measure the luminance of gray level 255 at center point

$$L_c = L(5)$$

$L(x)$ is corresponding to the luminance of the point X at Figure in Note (7).

Note (6) Measurement Setup:

The LCD module should be stabilized at given temperature for 30 minutes to avoid abrupt temperature change during measuring. In order to stabilize the luminance, the measurement should be executed after lighting Backlight for 30 minutes in a windless room.

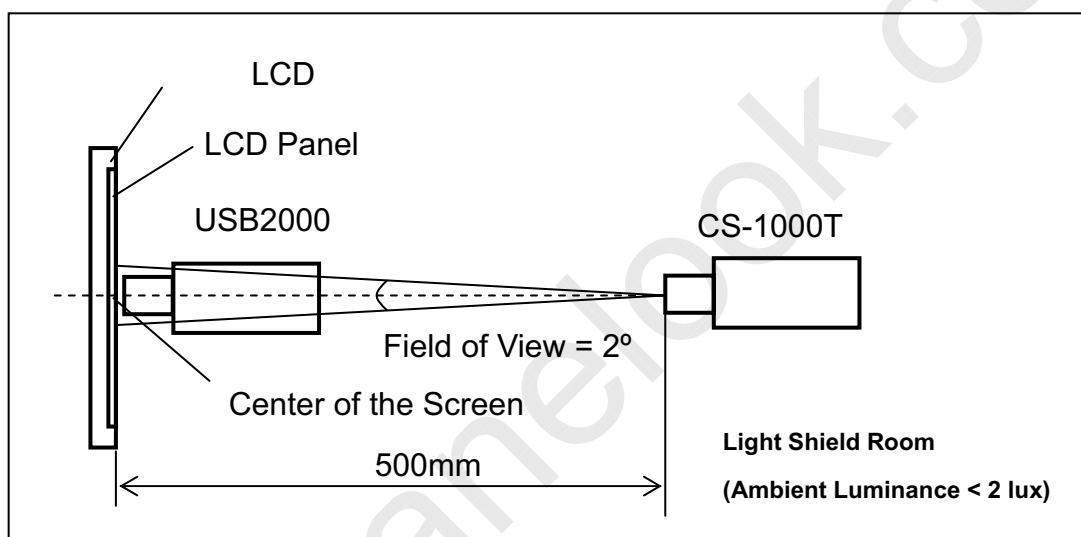
Note (7) Definition of Transmittance Variation ($\delta T\%$):

Measure the transmittance at 9 points

$$\delta T\% = \frac{\text{Maximum } [T\%(1), T\%(2), \dots T\%(9)]}{\text{Minimum } [T\%(1), T\%(2), \dots T\%(9)]}$$

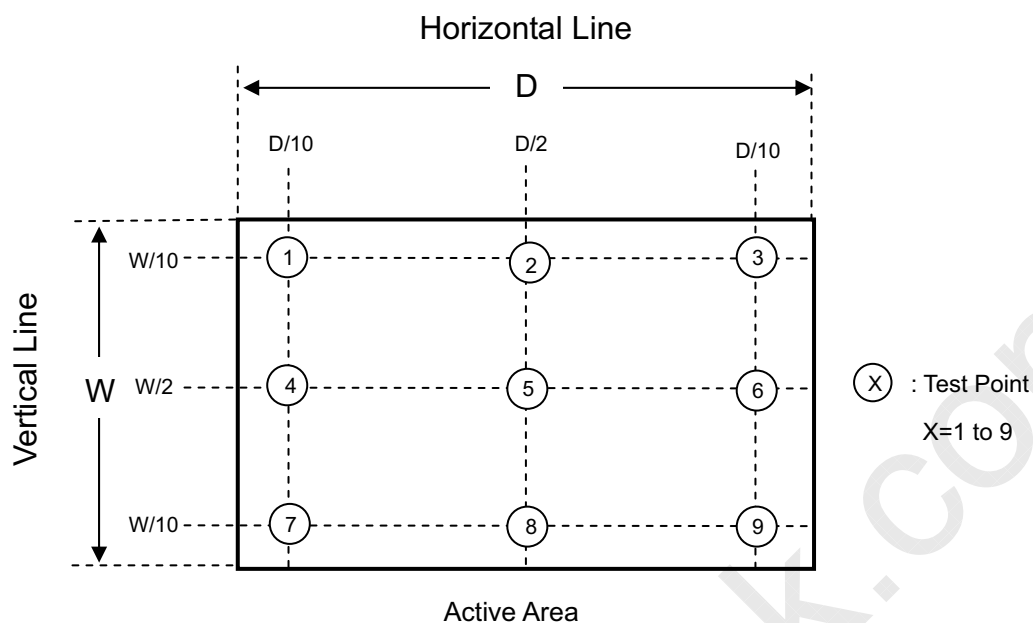

Note (8) Definition of Transmittance (T%):

Module is without signal input.

BLU is supplied by CMO

$$\text{Transmittance} = \frac{\text{Luminance of LCD module}}{\text{Luminance of backlight}} * 100\%$$

6. PACKAGING

6.1.PACKING SPECIFICATION

1. 20 LCD cells / 1 Dense Pack Box
2. Dense box dimension: 587 (L) X 410(W) X 141(H) mm
3. Weight: Approximately 22.5Kg (40 cells per Bag)

6.2 PACKING METHOD

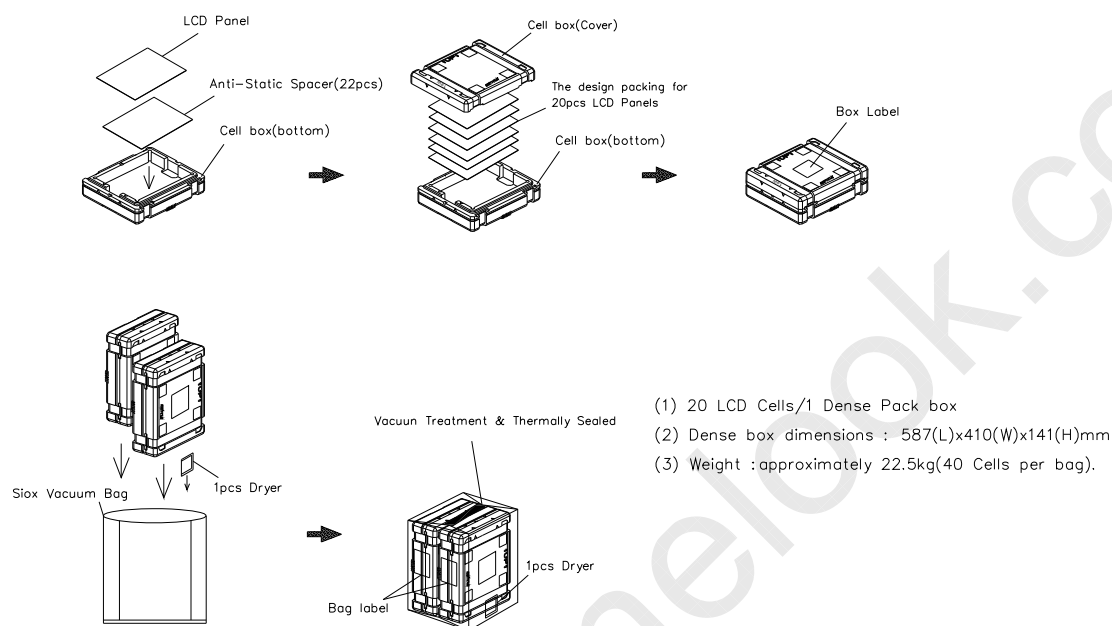

Figure. 6-1 Packing method



Pallet Stack:L1050*W870*H1249mm

Weight: 420 kgs

Total 36 pcs box

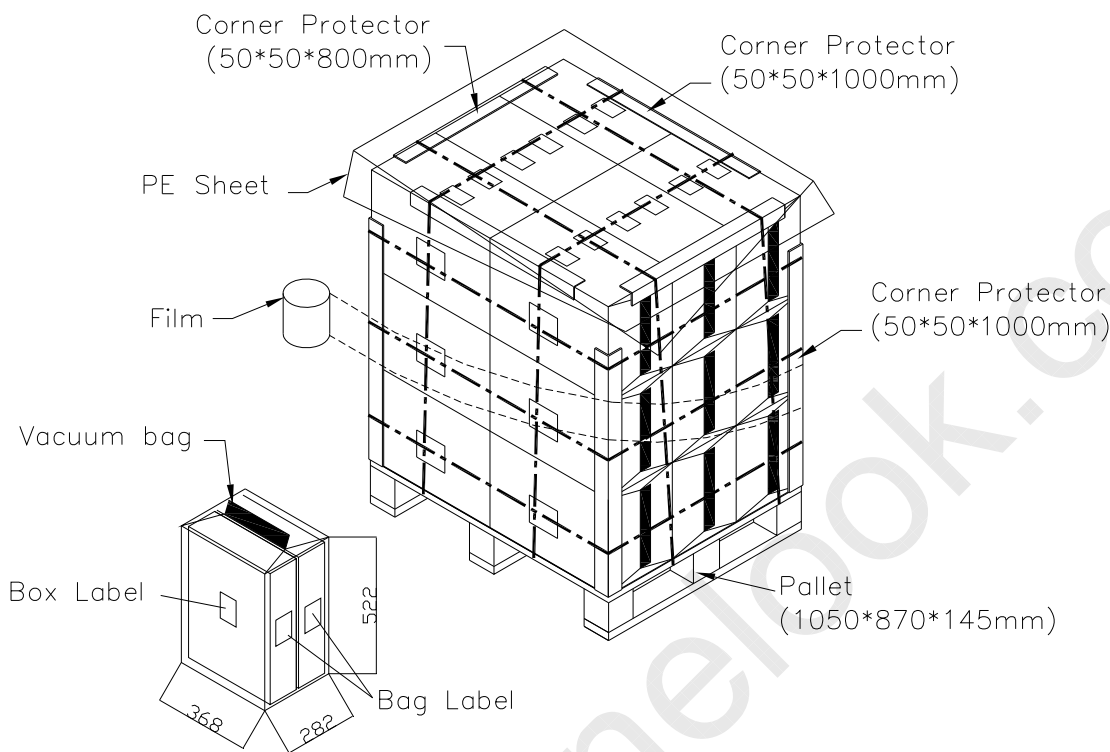

Figure. 6-2 Packing method

7. DEFINITION OF LABEL

1. Model Name: M185B1-C01
2. Panel Type: version control
3. Quantity: 20pcs / Dense Pack Box
4. Case ID: serial number.
5. Note: Notification, if necessary.
6. Barcode: Case ID in code39 format

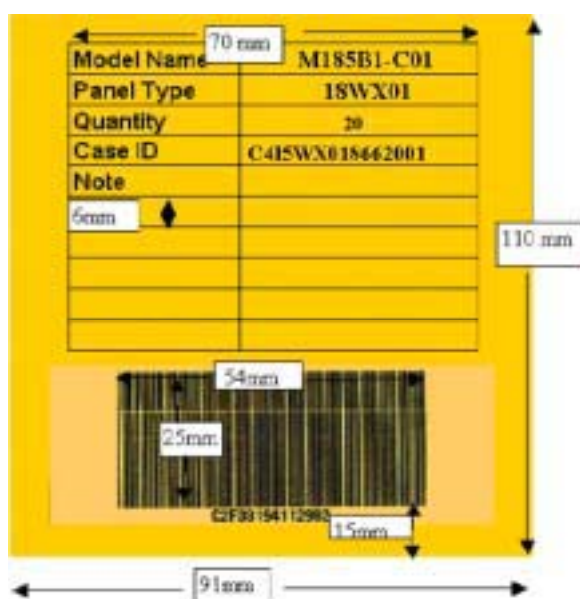

Figure. 7-1 Carton Label

8. PRECAUTIONS

8.1 ASSEMBLY AND HANDLING PRECAUTIONS

1. Do not apply rough force such as bending or twisting to the cell during assembly.
2. To assemble or install cell into customer's module can be only in clean working areas. The dust and oil may cause electrical short or worsen the polarizer.
3. It's not permitted to have pressure or impulse on the module because the LCD panel and Backlight will be damaged.
4. Use a soft dry cloth without chemicals for cleaning, because the surface of polarizer is very soft and easily scratched.
5. It is dangerous that moisture come into or contacted the LCD panel, because moisture may damage TFT circuit.
6. High temperature or humidity may reduce the performance of cell. Please store LCD cell within the specified storage conditions.

8.2 SAFETY PRECAUTIONS

1. If the liquid crystal material leaks from the panel, it should be kept away from the eyes or mouth. In case of contact with hands, skin or clothes, it has to be washed away thoroughly with soap.

9. RELIABILITY TEST

Environment test conditions are listed as following table.

Items	Required Condition	Note
Temperature Humidity Bias (THB)	Ta= 50°C , 80%RH, 240hours	(1)
High Temperature Operation (HTO)	Ta= 50°C , 50%RH , 240hours	
Low Temperature Operation (LTO)	Ta= 0°C , 240hours	
High Temperature Storage (HTS)	Ta= 60°C , 240hours	
Low Temperature Storage (LTS)	Ta= -20°C , 240hours	
Packing Vibration	1.14Grms Random, Frequency Range: 1 – 200 Hz Top & Bottom: 30 minutes (+Z), 10 min (-Z) Right & Left: 10 minutes (X) Back & Forth 10 minutes (Y)	(2)
Thermal Shock Test (TST)	-20°C/30min , 60°C / 30min , 100 cycles	(1)

Note (1) The tests are done with CMO LCD modules (M185B1-L01).

Note (2) The test is done with a package shown in Section 6.

10. PANEL DRAWING

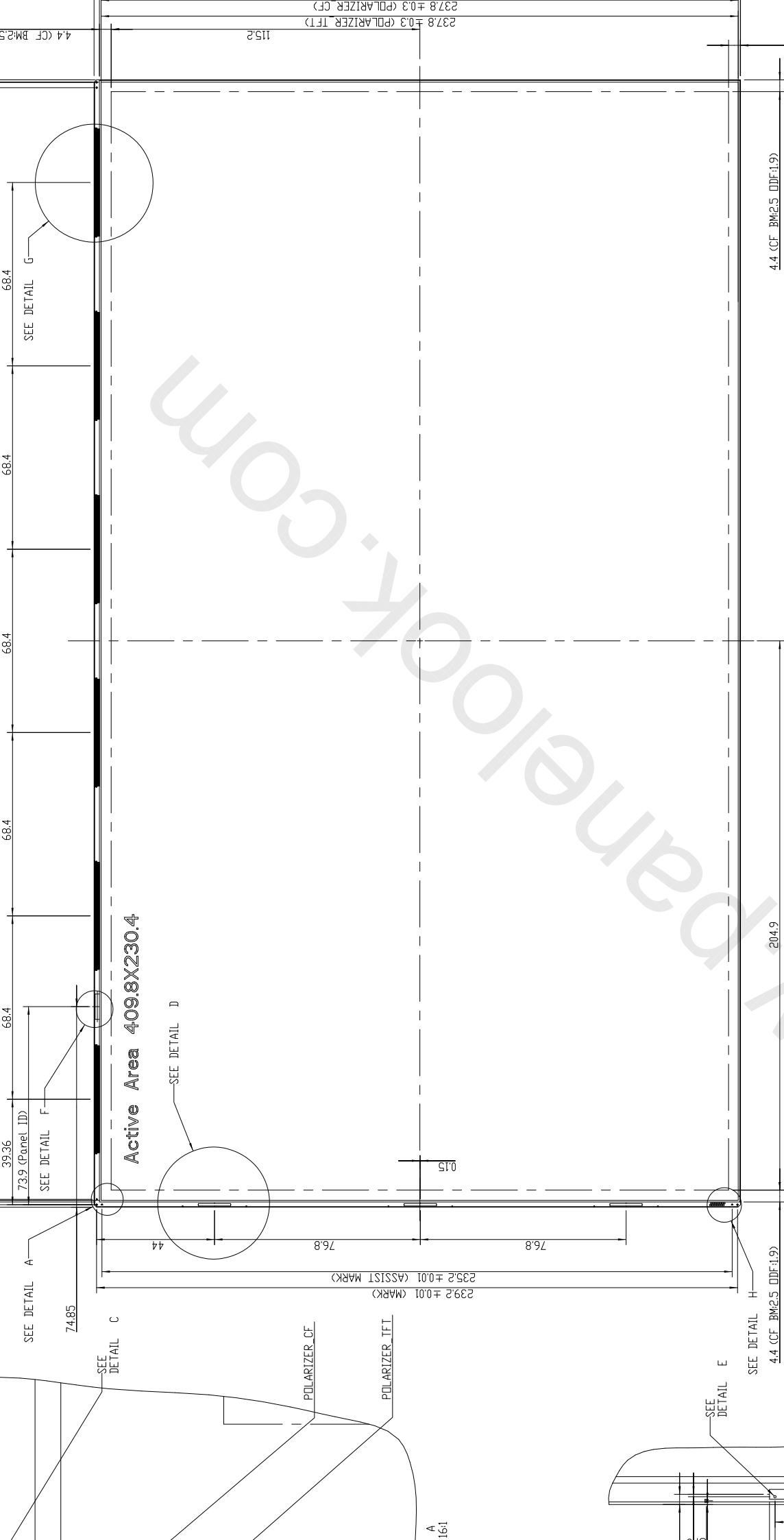

4.4 (CF BM2.5 DDF:1.9)

4.4 (CF BM2.5 DDF:1.9)

4.4 (CF BM2.5 DDF:1.9)

4.4 (CF BM2.5 DDF:1.9)

4.4 (CF BM2.5 DDF:1.9)

4.4 (CF BM2.5 DDF:1.9)

4.4 (CF BM2.5 DDF:1.9)

4.4 (CF BM2.5 DDF:1.9)

NOTE :
 1. GENERAL TOLERANCE : ±0.2mm
 2. * (C) MARKS THE PROCESS CENTER
 3. ** MARKS THE DESIGN CRITICAL

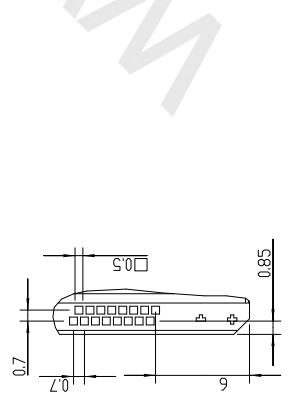
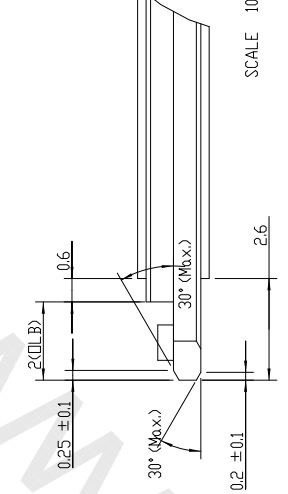
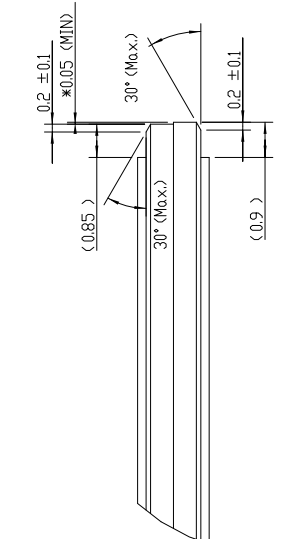

DETAIL H SCALE 4:1
 9.46
 6
 0.7
 0.5
 0.85
 0.7
 6
 9.46
 16:1
 A
 3.487
 908
 D
 DETAIL SCALE 4:1