

TFT LCD Approval Specification

MODEL NO.: M185B1-L07

Customer: _____ Approved by: _____ Note:

核准時間	部門	審核	角色	投票
2009-10-15 13:51:59	MTR 產品管理處		Director	Accept

- CONTENTS -

REVISION HISTORY	3
1. GENERAL DESCRIPTION	4
1.1 OVERVIEW	
1.2 FEATURES	
1.3 APPLICATION	
1.4 GENERAL SPECIFICATIONS	
1.5 MECHANICAL SPECIFICATIONS	
2. ABSOLUTE MAXIMUM RATINGS	5
2.1 ABSOLUTE RATINGS OF ENVIRONMENT	
2.2 ELECTRICAL ABSOLUTE RATINGS	
2.2.1 TFT LCD MODULE	
2.2.2 BACKLIGHT UNIT	
3. ELECTRICAL CHARACTERISTICS	7
3.1 TFT LCD MODULE	
3.2 Vcc Power Dip Condition:	
3.3 BACKLIGHT UNIT	
4. BLOCK DIAGRAM	11
4.1 TFT LCD MODULE	
4.2 BACKLIGHT UNIT	
5. INPUT TERMINAL PIN ASSIGNMENT	12
5.1 TFT LCD MODULE	
5.2 LVDS DATA MAPPING TABLE	
5.3 BACKLIGHT UNIT	
5.4 COLOR DATA INPUT ASSIGNMENT	
6. INTERFACE TIMING	15
6.1 INPUT SIGNAL TIMING SPECIFICATIONS	
6.2 POWER ON/OFF SEQUENCE	
7. OPTICAL CHARACTERISTICS	18
7.1 TEST CONDITIONS	
7.2 OPTICAL SPECIFICATIONS	
8. PACKAGING	21
8.1 PACKING SPECIFICATIONS	
8.2 PACKING METHOD	
9. DEFINITION OF LABELS	23
9.1 CMO MODULE LABEL	
10. RELIABILITY TEST	24
11. PRECAUTIONS	25
11.1 ASSEMBLY AND HANDLING PRECAUTIONS	
11.2 SAFETY PRECAUTIONS	
11.3 SAFETY STANDARDS	
11.4 STORAGE	
11.5 OPERATION CONDITION GUIDE	
11.6 OTHER	
12. MECHANICAL CHARACTERISTICS	26

REVISION HISTORY

Version	Date	Section	Description
Ver 2.0	Jul,01, 09'		M185B1-L07 Approval specification was first issued.
Ver 2.1	Aug,11, 09'	3.1	Revised TFT LCD Module-Ripple Voltage
		3.3	Revised Backlight Unit-Lamp Current
		6.1	Revised Input Signal Timing Specifications
		12	Revised Mechanical Characteristics-Drawing Notes
Ver 2.2	Sep,29,09'	1.4	Revised General Specifications- Surface Treatment
		1.5	Revised Mechanical Specifications-weight
		12	Revised Mechanical Characteristics-add data COF position

1. GENERAL DESCRIPTION

1.1 OVERVIEW

M185B1-L07 is a 18.5" TFT Liquid Crystal Display module with 2 CCFL Backlight unit and 30pin 1ch-LVDS interface. This module supports 1366 x 768 WXGA mode and can display up to 16.7M colors. The inverter module for Backlight is not built in.

1.2 FEATURES

- Contrast ratio 700:1
- Response time 5ms.
- Brightness 200nits
- Color saturation NTSC 72%.
- WXGA (1366 x 768 pixels) resolution.
- DE (Data Enable) only mode.
- LVDS (Low Voltage Differential Signaling) interface.
- RoHS compliance.

1.3 APPLICATION

- TFT LCD Monitor

1.4 GENERAL SPECIFICATIONS

Item	Specification	Unit	Note
Active Area	409.8 (H) × 230.4(V) (18.5" diagonal)	mm	(1)
Bezel Opening Area	413.4(H) x 234 (V)	mm	
Driver Element	a-Si TFT active matrix	-	-
Pixel Number	1366 x R.G.B. x 768	pixel	-
Pixel Pitch	0.3 (H) x 0.3 (V)	mm	-
Pixel Arrangement	RGB vertical stripe	-	-
Display Colors	16.7M	color	-
Transmissive Mode	Normally White	-	-
Surface Treatment	Anti-glare type, 3H hard coating	-	-
Module Power Consumption	15.21	Watt	(2)

1.5 MECHANICAL SPECIFICATIONS

Item	Min.	Typ.	Max.	Unit	Note	
Module Size	Horizontal(H)	429.87	430.37	430.87	mm	(1)
	Vertical(V)	254.1	254.6	255.1	mm	
	Depth(D)	9.8	10.5	11	mm	
Weight	-	1425	1475	g	-	

Note (1) Please refer to the attached drawings for more information of front and back outline dimensions.

Note (2) Please refer to sec. 3.1 & 3.2 in this document for more information of power consumption.

2. ABSOLUTE MAXIMUM RATINGS

2.1 ABSOLUTE RATINGS OF ENVIRONMENT

Item	Symbol	Value		Unit	Note
		Min.	Max.		
Storage Temperature	T_{ST}	-20	60	°C	(1)
Operating Ambient Temperature	T_{OP}	0	50	°C	(1), (2)
Shock (Non-Operating)	S_{NOP}	-	50	G	(3), (5)
Vibration (Non-Operating)	V_{NOP}	-	1.5	G	(4), (5)

Note (1) Temperature and relative humidity range is shown in the figure below.

- (a) 90 %RH Max. ($T_a \leq 40^\circ\text{C}$).
- (b) Wet-bulb temperature should be 39°C Max. ($T_a > 40^\circ\text{C}$).
- (c) No condensation.

Note (2) The temperature of panel display surface area should be 0°C Min. and 60°C Max.

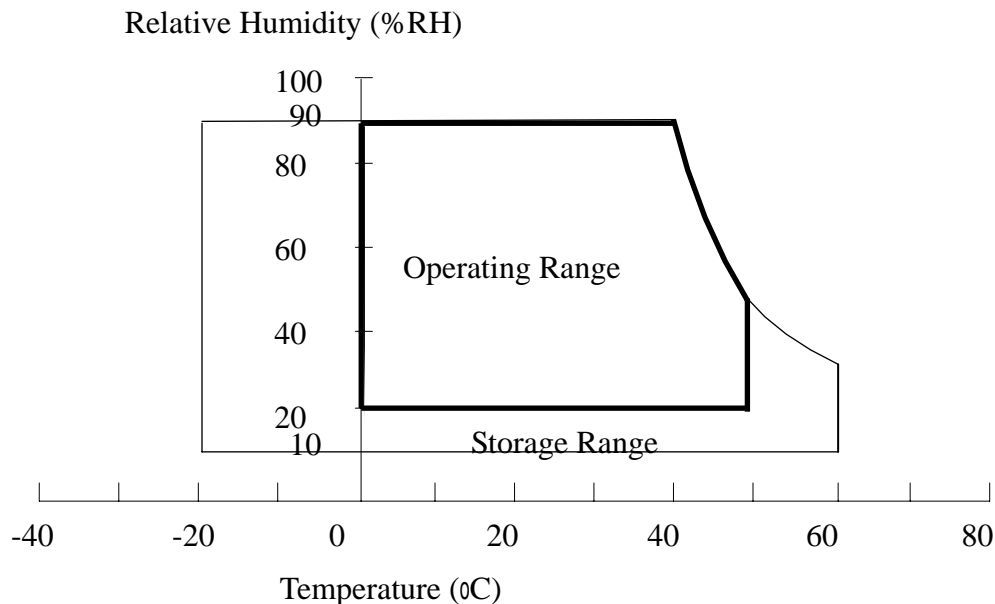

Note (3) 50G, 11ms, half sine wave, 1 time for $\pm X$, $\pm Y$, $\pm Z$.

Note (4) 10 ~ 300 Hz, 10min/cycle, 3 cycles each X, Y, Z.

Note (5) At testing Vibration and Shock, the fixture in holding the module has to be hard and rigid enough so that the module would not be twisted or bent by the fixture.

The fixing condition is shown as below:

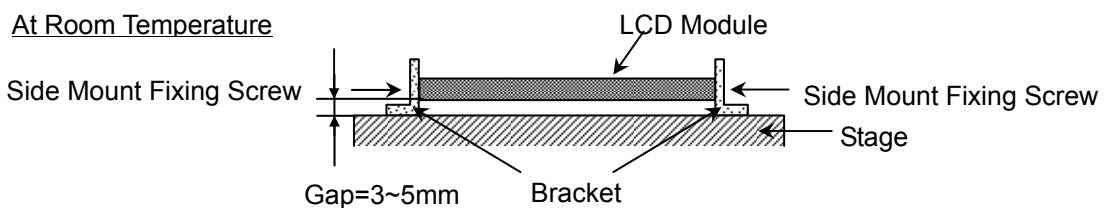

2.2 ELECTRICAL ABSOLUTE RATINGS

2.2.1 TFT LCD MODULE

Item	Symbol	Value		Unit	Note
		Min.	Max.		
Power Supply Voltage	Vcc	-0.3	+6.0	V	(1)
Logic Input Voltage	Vlogic	-0.3	2.7	V	

2.2.2 BACKLIGHT UNIT

Item	Symbol	Value		Unit	Note
		Min.	Max.		
Lamp Voltage	V_L	-	2.5K	V_{RMS}	(1), (2), $I_L = 8.0mA$
Lamp Current	I_L	2.0	8.0	mA_{RMS}	(1), (2)
Lamp Frequency	F_L	40	80	KHZ	

Note (1) Permanent damage to the device may occur if maximum values are exceeded. Function operation should be restricted to the conditions described under Normal Operating Conditions.

Note (2) Specified values are for lamp (Refer to 3.2 for further information).

3. ELECTRICAL CHARACTERISTICS

3.1 TFT LCD MODULE

Ta = 25 ± 2 °C

Parameter	Symbol	Value			Unit	Note
		Min.	Typ.	Max.		
Power Supply Voltage	V _{CC}	4.5	5.0	5.5	V	-
Ripple Voltage	V _{RP}	-	-	300	mV	-
Power on Rush Current	I _{RUSH}	-	-	3	A	(2)
Power Supply Current	White	-	0.44	0.6	A	(3)a
	Black	-	0.59	0.9	A	(3)b
	Vertical Stripe	-	0.61	0.9	A	(3)c
Power Consumption(without Backlight Unit)	PLCD	-	3.05	4.5	Watt	(4)
LVDS differential input voltage	V _{id}	100	-	600	mV	
LVDS common input voltage	V _{ic}	-	1.2	-	V	
Logic High Input Voltage	V _{IH}	2.0	-	2.7	V	
Logic Low Input Voltage	V _{IL}	-	-	0.5	V	

Note (1) The module should be always operated within above ranges.

Note (2) Power on rush current Measurement Conditions:

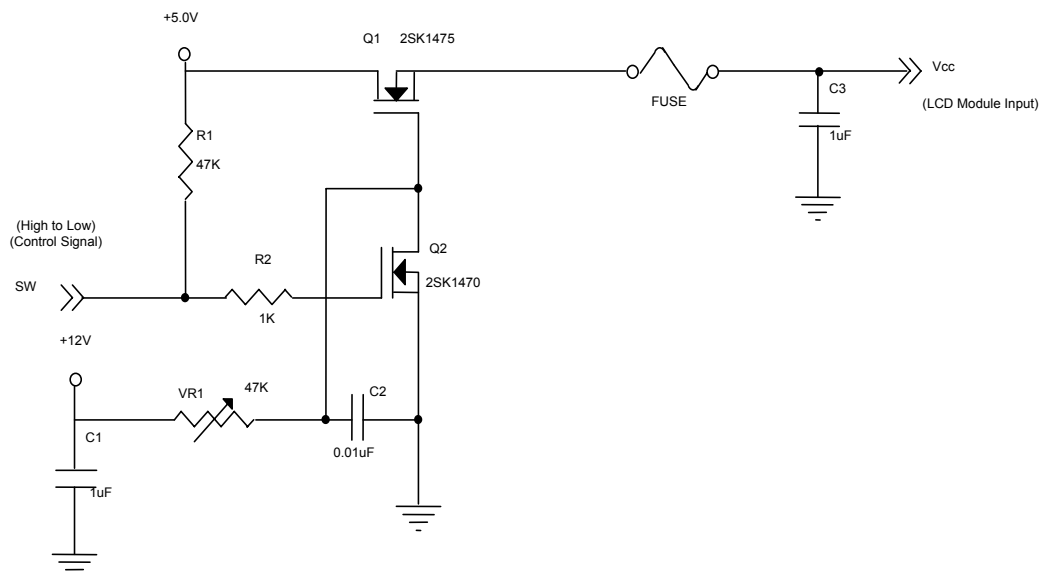

Vcc rising time is 470µs

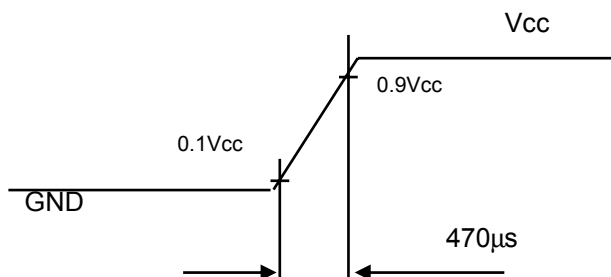

Note (3) The specified power supply current is under the conditions at $V_{cc} = 5.0\text{ V}$, $T_a = 25 \pm 2\text{ }^\circ\text{C}$, $f_v = 60\text{ Hz}$, whereas a power dissipation check pattern below is displayed.

a. White Pattern

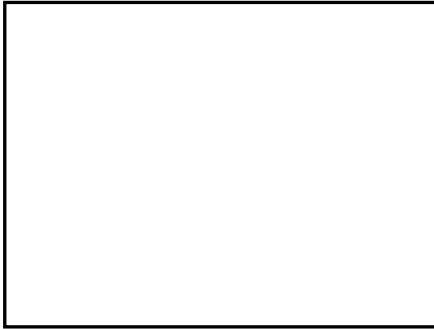

Active Area

b. Black Pattern



Active Area

c. Vertical Stripe Pattern

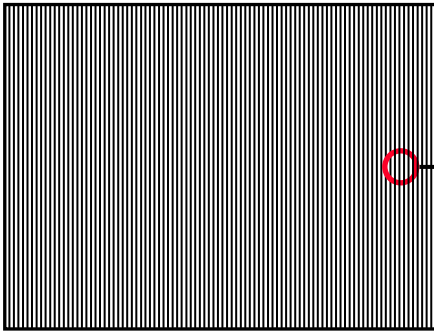

Active Area

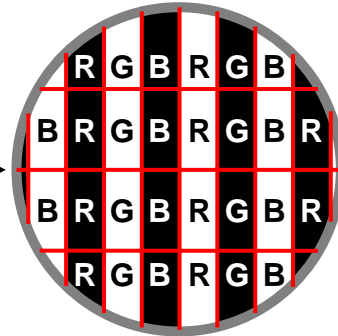

Note (4) The power consumption is specified at the pattern with the maximum current.

3.2 Vcc Power Dip Condition:

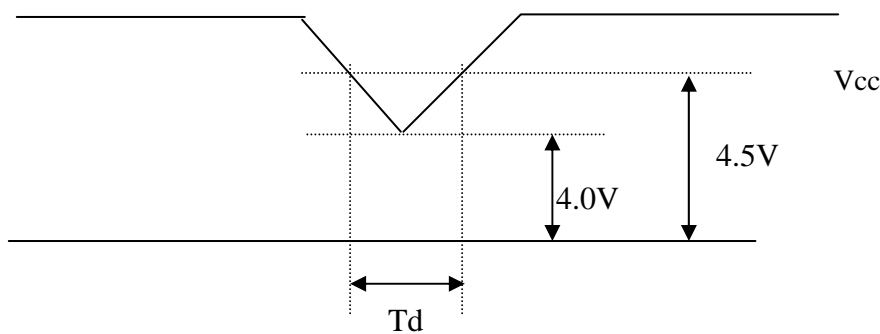

Dip condition: $4.0\text{V} \leq V_{cc} \leq 4.5\text{V}$, $T_d \leq 20\text{ms}$

3.3 BACKLIGHT UNIT

Ta = 25 ± 2 °C

Parameter	Symbol	Value			Unit	Note
		Min.	Typ.	Max.		
Lamp Input Voltage	V _L	---	760	836	V _{RMS}	I _L = 8.0 mA
Lamp Current	I _L	2.0	8.0	8.5	mA _{RMS}	(1)
Lamp Turn On Voltage	V _s	---	---	1680(0)	V _{RMS}	(2)
		---	---	1460(25)	V _{RMS}	(2)
Operating Frequency	F _L	40	---	80	KHz	(3)
Lamp Life Time	L _{BL}	50000	---	---	Hrs	(5), I _L = 8.0mA
Power Consumption	P _L	---	12.16	---	W	(4), I _L = 8.0 mA

Note (1) Lamp current is measured by current amplify & oscilloscope as shown below:

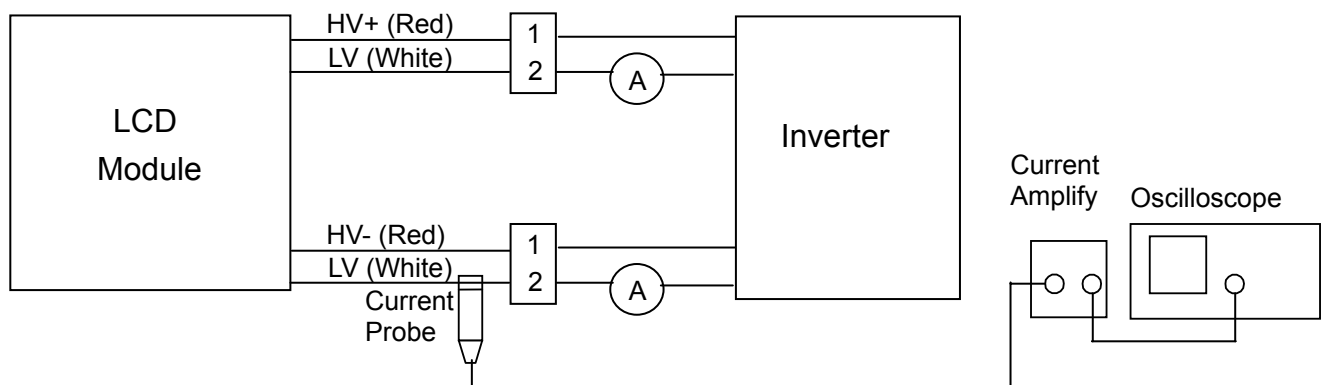

Measure equipment:
 Current Amplify: Tektronix TCPA300
 Current probe: Tektronix TCP312
 Oscilloscope: TDS3054B

Note (2) The voltage that must be larger than V_s should be applied to the lamp for more than 1 second after startup. Otherwise, the lamp may not be turned on normally. It is the value output voltage of NF circuit.

Note (3) The lamp frequency may produce interference with horizontal synchronization frequency from the display, which might cause line flow on the display. In order to avoid interference, the lamp frequency should be detached from the horizontal synchronization frequency and its harmonics as far as possible.

Note (4) $P_L = I_L \times V_L \times 2$ (for 2 lamps)

Note (5) The lifetime of lamp can be defined as the time in which it continues to operate under the condition Ta = 25 ± 2 °C and (I_L = 8.0 mA_{RMS}) until one of the following events occurs:

(a) When the brightness becomes 50% of its original value.

(b) When the effective ignition length becomes 80% of its original value.

(The effective ignition length is a scope that luminance is over 80% of that at the center point.)

Note (6) The waveform of the voltage output of inverter must be area-symmetric and the design of the inverter must have specifications for the modularized lamp. The performance of the Backlight,

such as lifetime or brightness, is greatly influenced by the characteristics of the DC-AC inverter for the lamp. All the parameters of an inverter should be carefully designed to avoid producing too much current leakage from high voltage output of the inverter. When designing or ordering the inverter please make sure that a poor lighting caused by the mismatch of the Backlight and the inverter (miss-lighting, flicker, etc.) never occurs. If the above situation is confirmed, the module should be operated in the same manners when it is installed in your instrument.

The output of the inverter must have symmetrical (negative and positive) voltage waveform and symmetrical current waveform. (Unsymmetrical ratio is less than 10%) Please do not use the inverter which has unsymmetrical voltage and unsymmetrical current and spike wave. Lamp frequency may produce interface with horizontal synchronous frequency and as a result this may cause beat on the display. Therefore lamp frequency shall be as away possible from the horizontal synchronous frequency and from its harmonics in order to prevent interference.

Requirements for a system inverter design, which is intended to have a better display performance, a better power efficiency and a more reliable lamp. It shall help increase the lamp lifetime and reduce its leakage current.

- a. The asymmetry rate of the inverter waveform should be 10% below;
- b. The distortion rate of the waveform should be within $2 \pm 10\%$;
- c. The ideal sine wave form shall be symmetric in positive and negative polarities

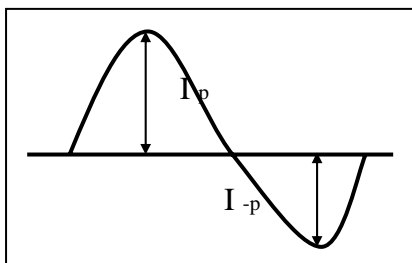

* Asymmetry rate:

$$| I_p - I_{-p} | / I_{rms} * 100\%$$

* Distortion rate

$$I_p \text{ (or } I_{-p}) / I_{rms}$$

4. BLOCK DIAGRAM

4.1 TFT LCD MODULE

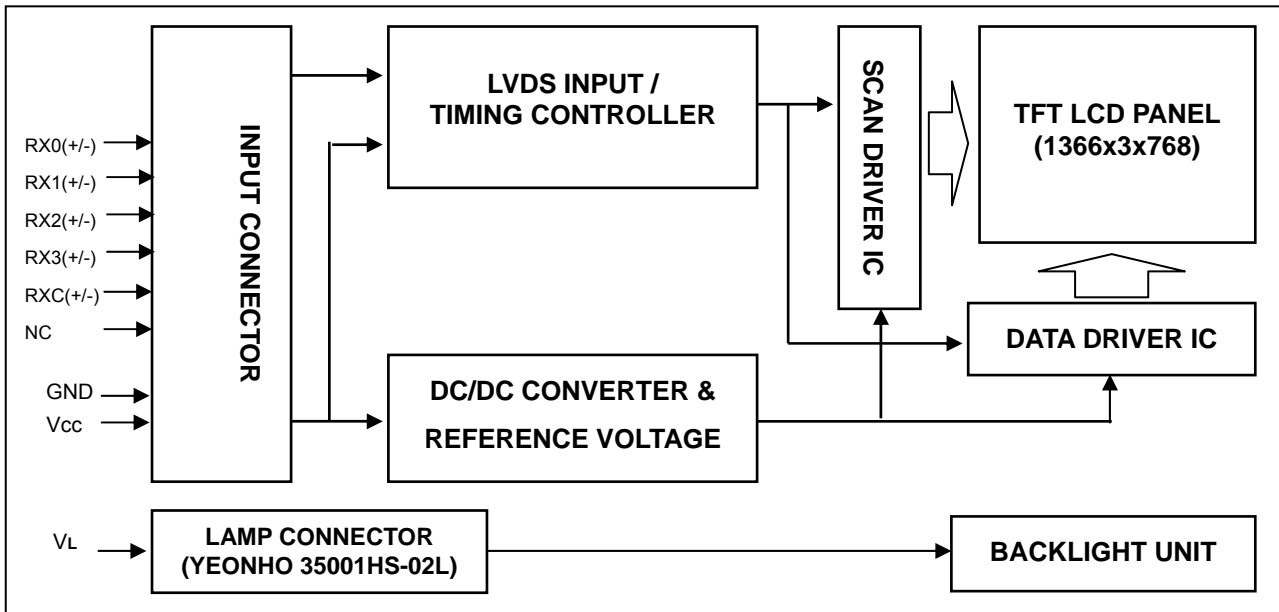

4.2 BACKLIGHT UNIT

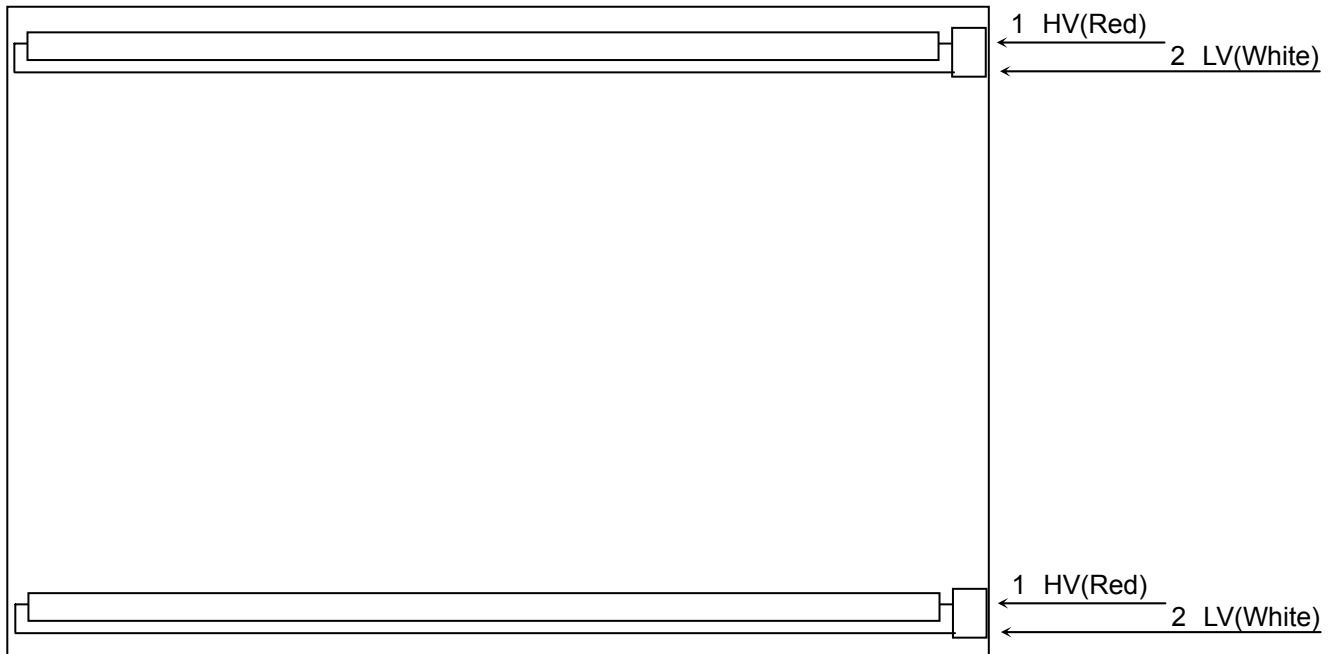

5. INPUT TERMINAL PIN ASSIGNMENT

5.1 TFT LCD MODULE

Pin	Name	Description
1	NC	Not connection, this pin should be open.
2	NC	Not connection, this pin should be open.
3	NC	Not connection, this pin should be open.
4	GND	Ground
5	RX0-	Negative LVDS differential data input. Channel 0
6	RX0+	Positive LVDS differential data input. Channel 0
7	GND	Ground
8	RX1-	Negative LVDS differential data input. Channel 1
9	RX1+	Positive LVDS differential data input. Channel 1
10	GND	Ground
11	RX2-	Negative LVDS differential data input. Channel 2
12	RX2+	Positive LVDS differential data input. Channel 2
13	GND	Ground
14	RXCLK-	Negative LVDS differential clock input.
15	RXCLK+	Positive LVDS differential clock input.
16	GND	Ground
17	RX3-	Negative LVDS differential data input. Channel 3
18	RX3+	Positive LVDS differential data input. Channel 3
19	GND	Ground
20	NC	Not connection, this pin should be open.
21	NC	Not connection, this pin should be open.
22	NC	Not connection, this pin should be open.
23	GND	Ground
24	GND	Ground
25	GND	Ground
26	Vcc	+5.0V power supply
27	Vcc	+5.0V power supply
28	Vcc	+5.0V power supply
29	Vcc	+5.0V power supply
30	Vcc	+5.0V power supply

Note (1) Connector Part No.: 093G30-B0001A(STARCONN) or MSCKT2407P30HA (STM)

Note (2) Mating Wire Cable Connector Part No.: FI-X30H(JAE) or FI-X30HL(JAE)

Note (3) Mating FFC Cable Connector Part No.: 217007-013001 (P-TWO) or JF05X030-1 (JAE)

Note (4) The first pixel is odd.

Note (5) Input signal of even and odd clock should be the same timing.

5.2 LVDS DATA MAPPING TABLE

LVDS Channel 0	LVDS output	D7	D6	D4	D3	D2	D1	D0
	Data order	G0	R5	R4	R3	R2	R1	R0
LVDS Channel 1	LVDS output	D18	D15	D14	D13	D12	D9	D8
	Data order	B1	B0	G5	G4	G3	G2	G1
LVDS Channel 2	LVDS output	D26	D25	D24	D22	D21	D20	D19
	Data order	DE	NA	NA	B5	B4	B3	B2
LVDS Channel 3	LVDS output	D23	D17	D16	D11	D10	D5	D27
	Data order	NA	B7	B6	G7	G6	R7	R6

5.3 BACKLIGHT UNIT:

Pin	Symbol	Description	Remark
1	HV	High Voltage	Red
2	LV	Low Voltage	White

Note (1) Connector Part No.: YEONHO 35001HS-02L or equivalent

5.4 COLOR DATA INPUT ASSIGNMENT

The brightness of each primary color (red, green and blue) is based on the 8-bit gray scale data input for the color. The higher the binary input, the brighter the color. The table below provides the assignment of color versus data input.

Color		Data Signal																							
		Red								Green						Blue									
		R7	R6	R5	R4	R3	R2	R1	R0	G7	G6	G5	G4	G3	G2	G1	G0	B7	B6	B5	B4	B3	B2	B1	B0
Basic Colors	Black	0	0	0	0	0	0	0	0	0	0	0	0	0	0	0	0	0	0	0	0	0	0	0	0
	Red	1	1	1	1	1	1	1	1	0	0	0	0	0	0	0	0	0	0	0	0	0	0	0	0
	Green	0	0	0	0	0	0	0	0	1	1	1	1	1	1	1	1	0	0	0	0	0	0	0	0
	Blue	0	0	0	0	0	0	0	0	0	0	0	0	0	0	0	0	1	1	1	1	1	1	1	1
	Cyan	0	0	0	0	0	0	0	0	1	1	1	1	1	1	1	1	1	1	1	1	1	1	1	1
	Magenta	1	1	1	1	1	1	1	1	0	0	0	0	0	0	0	0	1	1	1	1	1	1	1	1
	Yellow	1	1	1	1	1	1	1	1	1	1	1	1	1	1	1	1	0	0	0	0	0	0	0	0
	White	1	1	1	1	1	1	1	1	1	1	1	1	1	1	1	1	1	1	1	1	1	1	1	1
Gray Scale Of Red	Red(0) / Dark	0	0	0	0	0	0	0	0	0	0	0	0	0	0	0	0	0	0	0	0	0	0	0	
	Red(1)	0	0	0	0	0	0	0	1	0	0	0	0	0	0	0	0	0	0	0	0	0	0	0	
	Red(2)	0	0	0	0	0	0	1	0	0	0	0	0	0	0	0	0	0	0	0	0	0	0	0	
	:	:	:	:	:	:	:	:	:	:	:	:	:	:	:	:	:	:	:	:	:	:	:	:	
	:	:	:	:	:	:	:	:	:	:	:	:	:	:	:	:	:	:	:	:	:	:	:	:	
	:	:	:	:	:	:	:	:	:	:	:	:	:	:	:	:	:	:	:	:	:	:	:	:	
	Red(253)	1	1	1	1	1	1	0	1	0	0	0	0	0	0	0	0	0	0	0	0	0	0	0	
	Red(254)	1	1	1	1	1	1	1	0	0	0	0	0	0	0	0	0	0	0	0	0	0	0	0	
Red(255)	1	1	1	1	1	1	1	1	0	0	0	0	0	0	0	0	0	0	0	0	0	0	0		
Gray Scale Of Green	Green(0) / Dark	0	0	0	0	0	0	0	0	0	0	0	0	0	0	0	0	0	0	0	0	0	0	0	
	Green(1)	0	0	0	0	0	0	0	0	0	0	0	0	0	0	0	1	0	0	0	0	0	0	0	
	Green(2)	0	0	0	0	0	0	0	0	0	0	0	0	0	0	1	0	0	0	0	0	0	0	0	
	:	:	:	:	:	:	:	:	:	:	:	:	:	:	:	:	:	:	:	:	:	:	:	:	
	:	:	:	:	:	:	:	:	:	:	:	:	:	:	:	:	:	:	:	:	:	:	:	:	
	:	:	:	:	:	:	:	:	:	:	:	:	:	:	:	:	:	:	:	:	:	:	:	:	
	Green(253)	0	0	0	0	0	0	0	0	1	1	1	1	1	1	0	1	0	0	0	0	0	0	0	
	Green(254)	0	0	0	0	0	0	0	0	1	1	1	1	1	1	1	0	0	0	0	0	0	0	0	
Green(255)	0	0	0	0	0	0	0	0	1	1	1	1	1	1	1	0	0	0	0	0	0	0	0		
Gray Scale Of Blue	Blue(0) / Dark	0	0	0	0	0	0	0	0	0	0	0	0	0	0	0	0	0	0	0	0	0	0	0	
	Blue(1)	0	0	0	0	0	0	0	0	0	0	0	0	0	0	0	0	0	0	0	0	0	0	1	
	Blue(2)	0	0	0	0	0	0	0	0	0	0	0	0	0	0	0	0	0	0	0	0	0	0	1	
	:	:	:	:	:	:	:	:	:	:	:	:	:	:	:	:	:	:	:	:	:	:	:	:	
	:	:	:	:	:	:	:	:	:	:	:	:	:	:	:	:	:	:	:	:	:	:	:	:	
	:	:	:	:	:	:	:	:	:	:	:	:	:	:	:	:	:	:	:	:	:	:	:	:	
	Blue(253)	0	0	0	0	0	0	0	0	0	0	0	0	0	0	0	1	1	1	1	1	1	1	0	
	Blue(254)	0	0	0	0	0	0	0	0	0	0	0	0	0	0	0	1	1	1	1	1	1	1	0	
Blue(255)	0	0	0	0	0	0	0	0	0	0	0	0	0	0	0	1	1	1	1	1	1	1	1		

Note (1) 0: Low Level Voltage, 1: High Level Voltage

6. INTERFACE TIMING

6.1 INPUT SIGNAL TIMING SPECIFICATIONS

The input signal timing specifications are shown as the following table and timing diagram.

Signal	Item	Symbol	Min.	Typ.	Max.	Unit	Note
LVDS Clock	Frequency	F_c	60.0	76	96	MHz	-
	Period	T_c	-	13.0	-	ns	-
	Input cycle to cycle jitter	T_{rcj}			200	ps	(1)
	Spread spectrum modulation range	$F_{clk_{in_mod}}$	$F_c*(-2\%)$		$F_c*2\%$	MHz	(2)
	Spread spectrum modulation frequency	F_{SSM}			200	KHz	
	High Time	T_{ch}	-	4/7	-	T_c	-
	Low Time	T_{cl}	-	3/7	-	T_c	-
LVDS Data	Setup Time	T_{lvs}	600	-	-	ps	(3)
	Hold Time	T_{lvh}	600	-	-	ps	
Vertical Active Display Term	Frame Rate	F_r	50	60	75	Hz	$T_v = T_{vd} + T_{vb}$
	Total	T_v	800	806	815	T_h	-
	Display	T_{vd}	768	768	768	T_h	-
	Blank	T_{vb}	$T_v - T_{vd}$	38	$T_v - T_{vd}$	T_h	-
Horizontal Active Display Term	Total	T_h	1500	1560	1570	T_c	$T_h = T_{hd} + T_{hb}$
	Display	T_{hd}	1366	1366	1366	T_c	-
	Blank	T_{hb}	$T_h - T_{hd}$	194	$T_h - T_{hd}$	T_c	-

Note: Because this module is operated by DE only mode, Hsync and Vsync input signals are ignored.

INPUT SIGNAL TIMING DIAGRAM

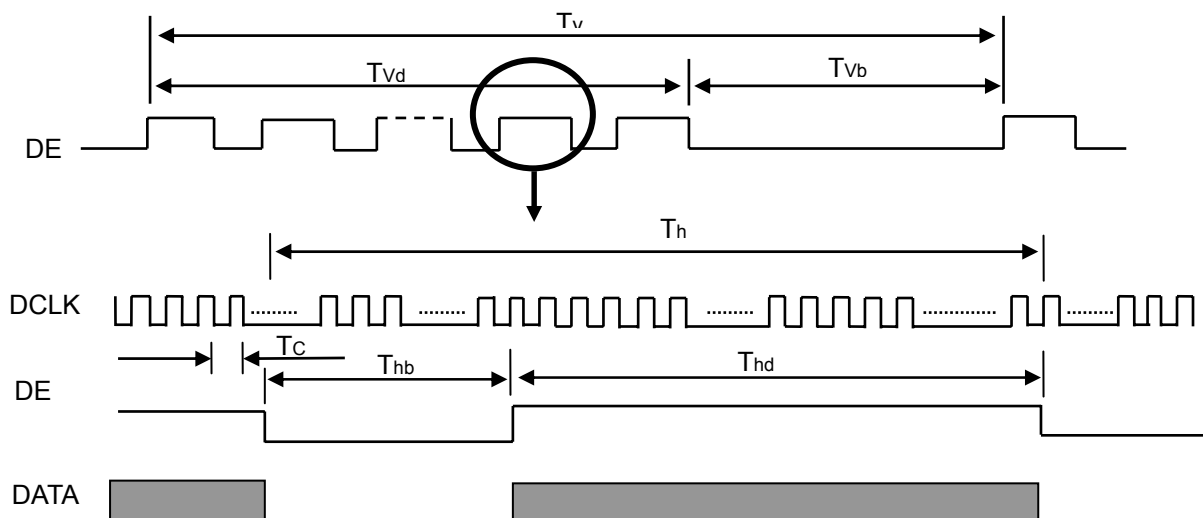

Note (1) The input clock cycle-to-cycle jitter is defined as below figures. $T_{rcl} = |T_1 - T_1|$

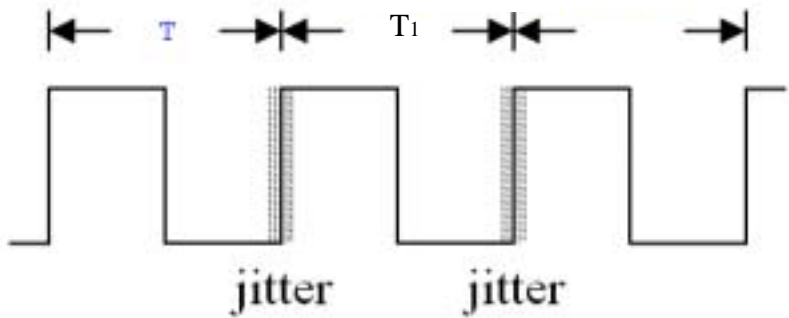

Note (2) The SSCG (Spread spectrum clock generator) is defined as below figures.

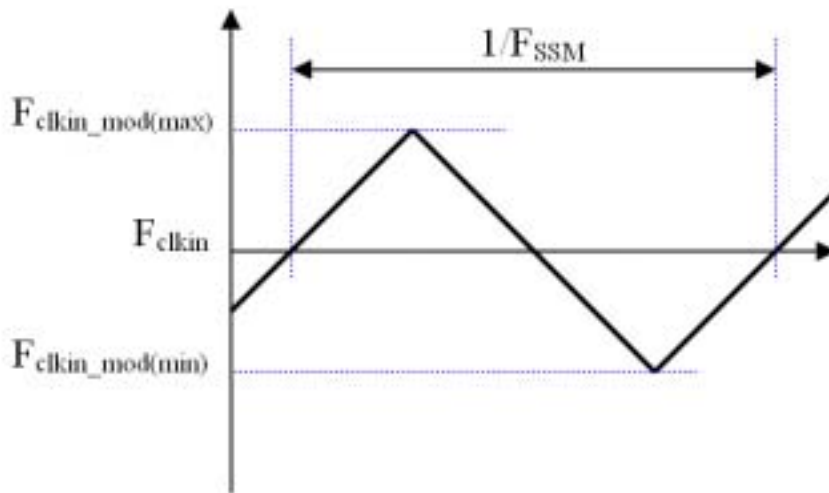

Note (3) The LVDS timing diagram and setup/hold time is defined and showing as the following figures.

LVDS RECEIVER INTERFACE TIMING DIAGRAM

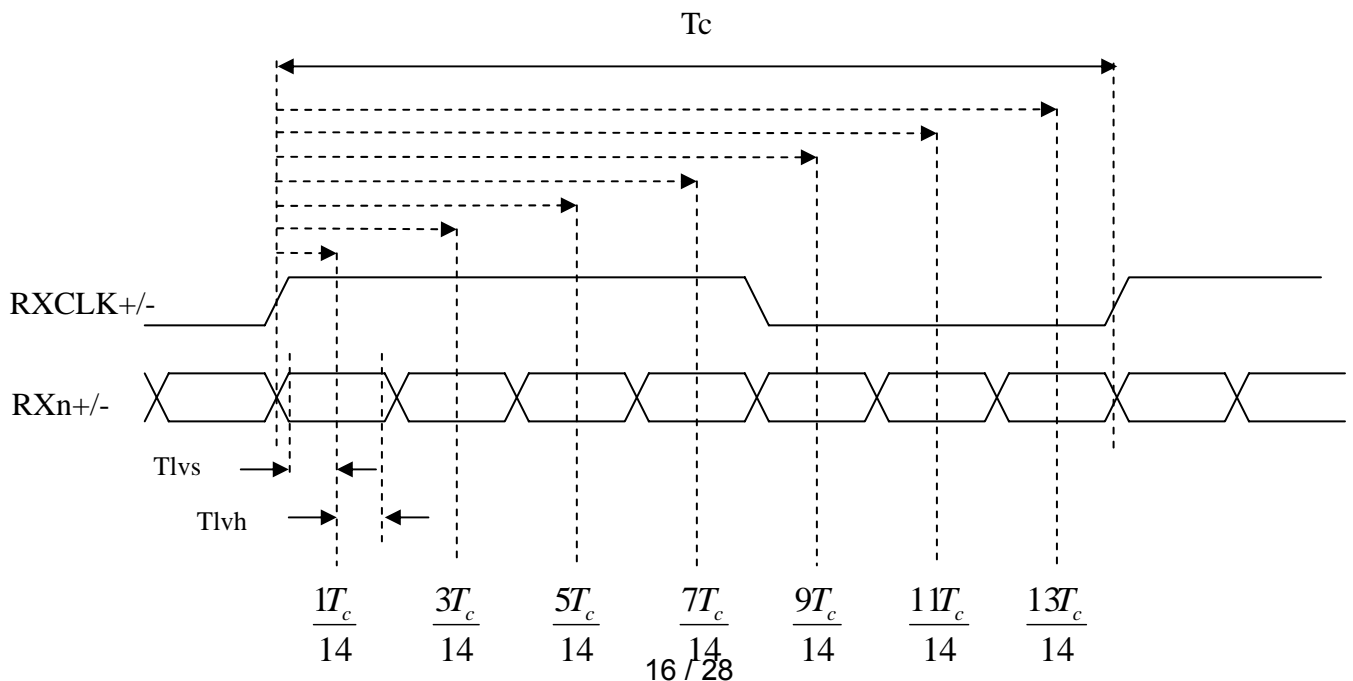

6.2 POWER ON/OFF SEQUENCE

To prevent a latch-up or DC operation of LCD module, the power on/off sequence should be as the diagram below.

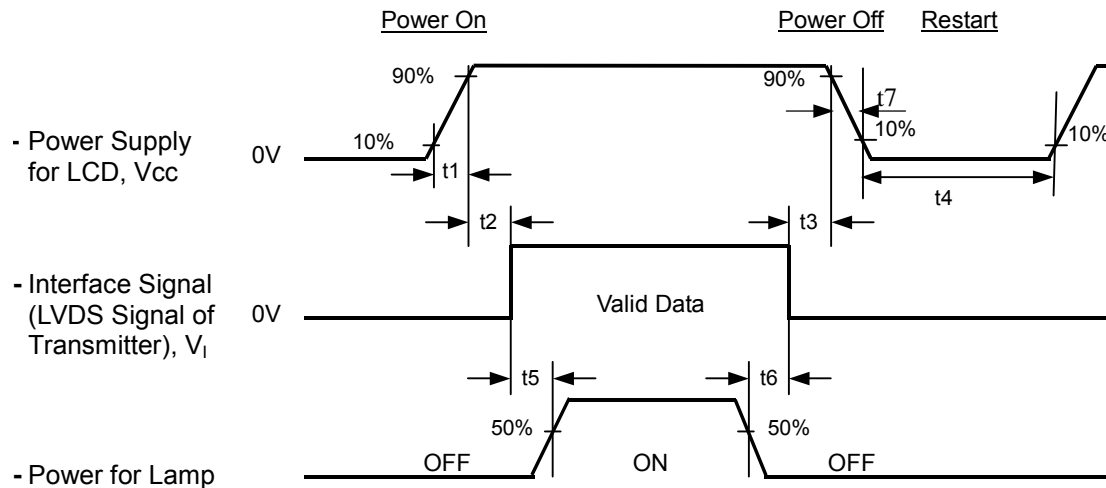

Timing Specifications:

0.5 < t ₁	5msec
0 < t ₂	50 msec
0 < t ₃	50 msec
t ₄	500 msec
t ₅	450 msec
t ₆	90 msec
5 t ₇	100 msec

Note.

- (1) The supply voltage of the external system for the module input should be the same as the definition of V_{cc}.
- (2) Apply the lamp voltage within the LCD operation range. When the backlight turns on before the LCD operation of the LCD turns off, the display may momentarily become abnormal screen.
- (3) In case of V_{CC} = off level, please keep the level of input signals on the low or keep a high impedance.
- (4) T₄ should be measured after the module has been fully discharged between power off and on period.
- (5) Interface signal shall not be kept at high impedance when the power is on.
- (6) CMO won't take any responsibility for the products which are damaged by the customers not following the Power Sequence.
- (7) There might be slight electronic noise when LCD is turned off (even backlight unit is also off). To avoid this symptom, we suggest "V_{cc} falling timing" to follow "t₇ spec".

7. OPTICAL CHARACTERISTICS

7.1 TEST CONDITIONS

Item	Symbol	Value	Unit
Ambient Temperature	Ta	25±2	°C
Ambient Humidity	Ha	50±10	%RH
Supply Voltage	V _{CC}	5V	V
Input Signal	According to typical value in "3. ELECTRICAL CHARACTERISTICS"		
Lamp Current	I _L	8.0 ± 0.5	mA
Inverter Operating Frequency	F _L	55±5	KHz
Inverter	Logah MIT70070.50		

7.2 OPTICAL SPECIFICATIONS

The relative measurement methods of optical characteristics are shown in 7.2. The following items should be measured under the test conditions described in 7.1 and stable environment shown in Note (5).

Item	Symbol	Condition	Min.	Typ.	Max.	Unit	Note	
Color Chromaticity (CIE 1931)	Red	Rx	$\theta_x=0^\circ, \theta_y=0^\circ$ CS-1000T	Typ - 0.03	0.646	Typ + 0.03	-	(1), (5)
		Ry			0.334			
	Green	Gx			0.284			
		Gy			0.602			
	Blue	Bx			0.152			
		By			0.076			
	White	Wx			0.313			
		Wy			0.329			
Center Luminance of White (Center of Screen)	L _C		150	200	-	cd/m ²	(4), (5)	
Contrast Ratio	CR		500	700	-	-	(2), (5)	
Response Time	T _R	$\theta_x=0^\circ, \theta_y=0^\circ$	-	1.5	2.5	ms	(3)	
	T _F		-	3.5	5.5			
White Variation	ΔW	$\theta_x=0^\circ, \theta_y=0^\circ$ USB2000	-	-	1.33	-	(5), (6)	
Viewing Angle	Horizontal	θ_{x+}	CR 10 USB2000	40	45	-	Deg.	(1), (5)
		θ_{x-}		40	45	-		
	Vertical	θ_{y+}		15	20	-		
		θ_{y-}		40	45	-		
Viewing Angle	Horizontal	θ_{x+}	CR 5 USB2000	50	55	-	Deg.	(1), (5)
		θ_{x-}		50	55	-		
	Vertical	θ_{y+}		25	30	-		
		θ_{y-}		50	55	-		

Note (1) Definition of Viewing Angle (θ_x , θ_y):

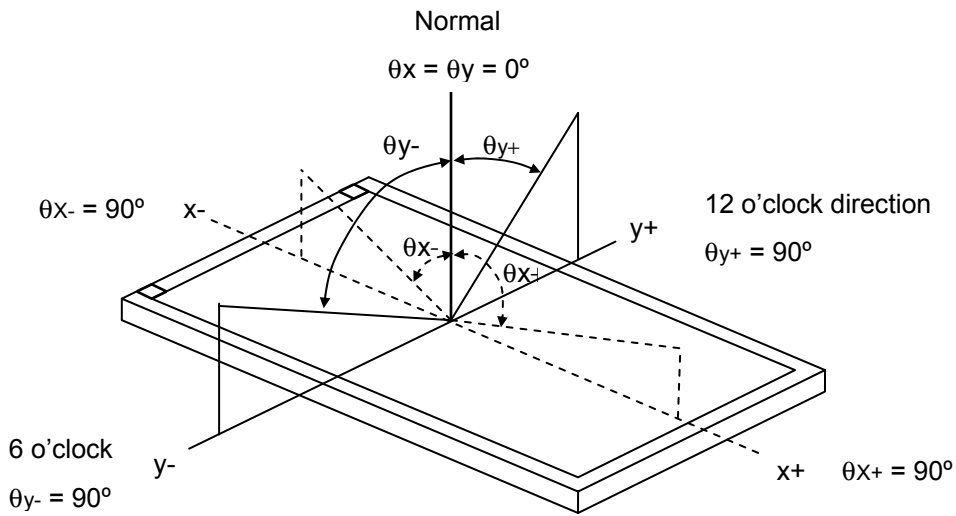

Note (2) Definition of Contrast Ratio (CR):

The contrast ratio can be calculated by the following expression.

$$\text{Contrast Ratio (CR)} = L_{255} / L_0$$

L255: Luminance of gray level 255

L 0: Luminance of gray level 0

$$\text{CR} = \text{CR (5)}$$

CR (X) is corresponding to the Contrast Ratio of the point X at Figure in Note (6).

Note (3) Definition of Response Time (T_R , T_F):

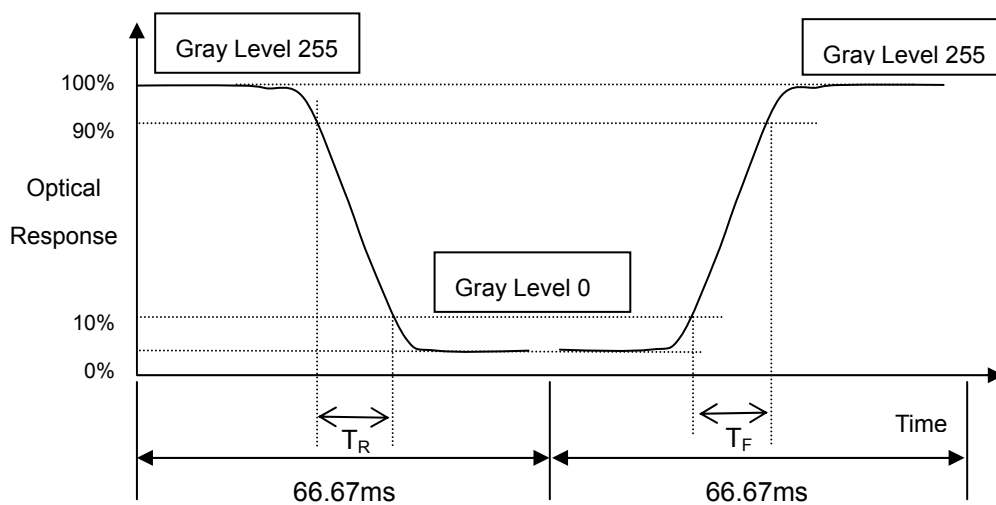

Note (4) Definition of Luminance of White (L_c):

Measure the luminance of gray level 255 at center point

$$L_c = L(5)$$

$L(x)$ is corresponding to the luminance of the point X at Figure in Note (6).

Note (5) Measurement Setup:

The LCD module should be stabilized at given temperature for 20 minutes to avoid abrupt temperature change during measuring. In order to stabilize the luminance, the measurement should be executed after lighting Backlight for 20 minutes in a windless room.

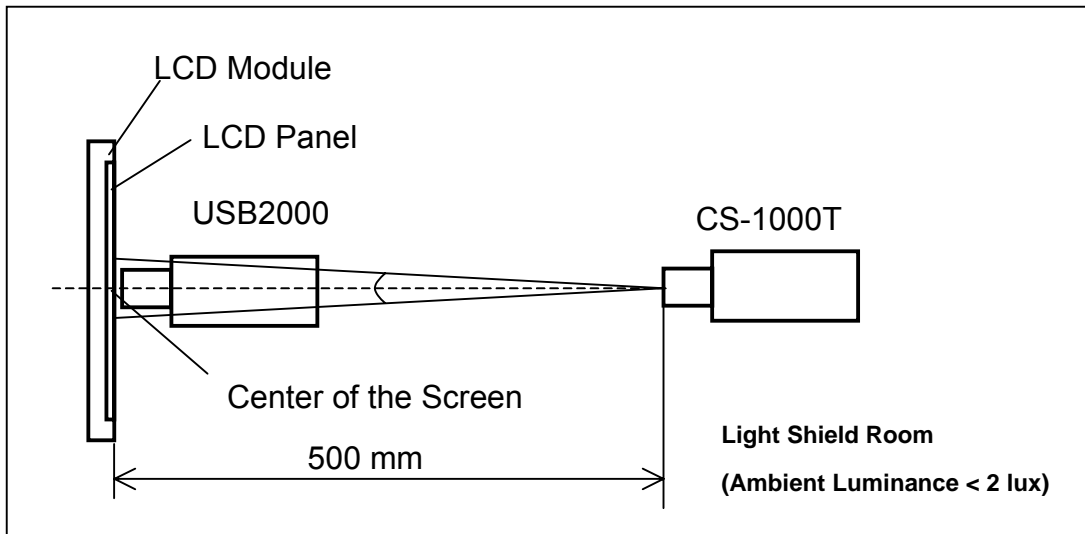

Note (6) Definition of White Variation (δW):

Measure the luminance of gray level 255 at 9 points

$$\delta W = \text{Maximum} [L(1), L(2) \dots L(4), L(9)] / \text{Minimum} [L(1), L(2) \dots L(4), L(9)]$$

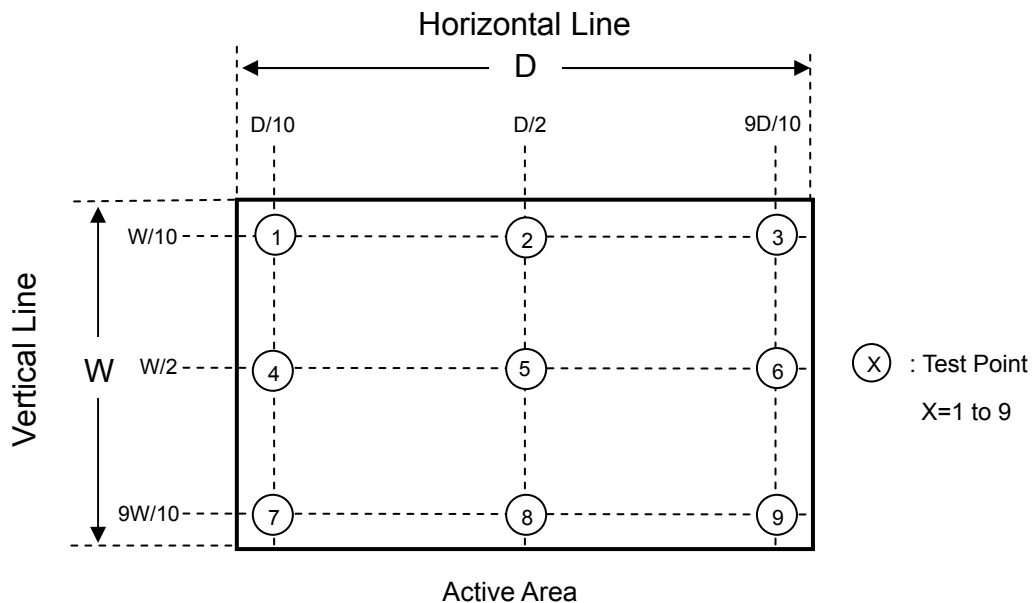

Active Area

8. PACKAGING :

8.1 PACKING SPECIFICATIONS

- (1) 12 LCD modules / 1 Box
- (2) Box dimensions: 525(L) X 284 (W) X 360 (H) mm
- (3) Weight: 19.9Kg (12 modules per box)

8.2 PACKING METHOD

- (1) Carton Packing should have no failure in the following reliability test items.

Test Item	Test Conditions	Note
Vibration	ISTA STANDARD Random, Frequency Range: 1 – 200 Hz Top & Bottom: 30 minutes (+Z), 10 min (-Z), Right & Left: 10 minutes (X) Back & Forth 10 minutes (Y)	Non Operation
Dropping Test	1 Corner, 3 Edge, 6 Face, 45.7cm	Non Operation

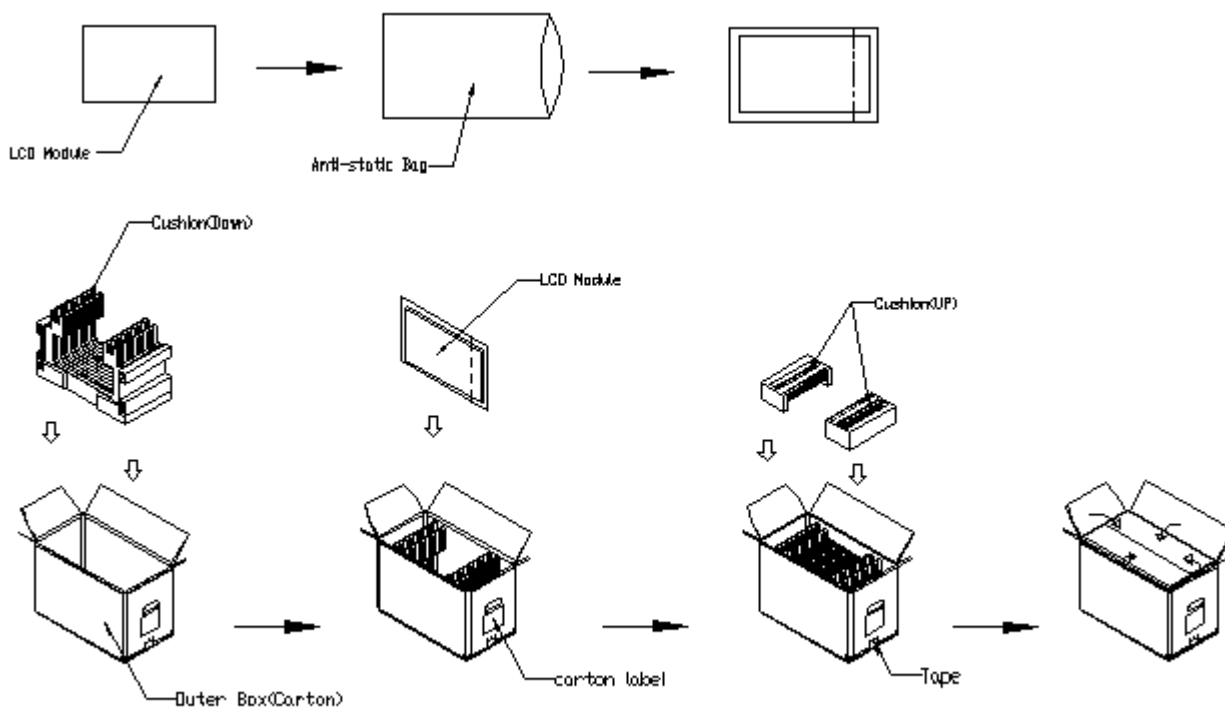

Figure. 8-1 Packing method

For ocean shipping

Sea / Land Transportation (40ft HQ Container)

Sea / Land Transportation (40ft Container)

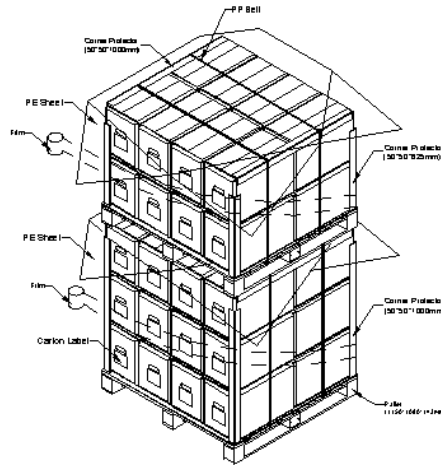
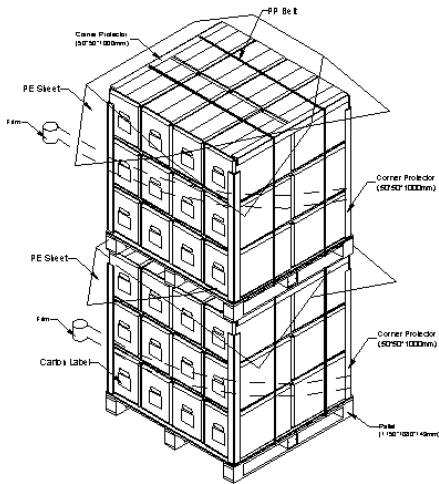

Figure. 8-2 Packing method

For air transport

Air Transportation

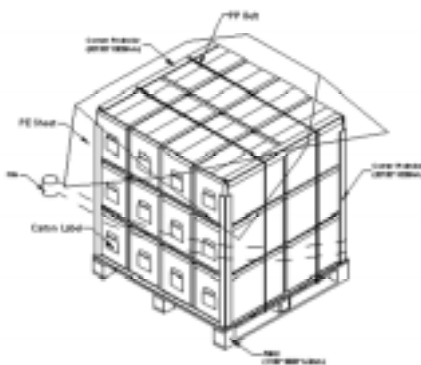

Figure. 8-3 Packing method

9. DEFINITION OF LABELS

9.1 CMO MODULE LABEL

The barcode nameplate is pasted on each module as illustration, and its definitions are as following explanation.



- (a) Model Name: M185B1-L07
- (b) Revision: Rev. XX, for example: A0, A1... B1, B2... or C1, C2...etc.
- (c) CMO barcode definition:

Serial ID: XX-XX-X-XX-YMD-L-NNNN

Code	Meaning	Description
XX	CMO internal use	-
XX	Revision	Cover all the change
X	CMO internal use	-
XX	CMO internal use	-
YMD	Year, month, day	Year: 2001=1, 2002=2, 2003=3, 2004=4... Month: 1~12=1, 2, 3, ~, 9, A, B, C Day: 1~31=1, 2, 3, ~, 9, A, B, C, ~, W, X, Y, exclude I, O,
L	Product line #	Line 1=1, Line 2=2, Line 3=3, ...
NNNN	Serial number	Manufacturing sequence of product

- (d) Customer's barcode definition:

Serial ID: CM-18B17-X-X-X-XX-L-XX-L-YMD-NNNN

Code	Meaning	Description
CM	Supplier code	CMO=CM
18B17	Model number	M185B1-L07 = 18B17
X	Revision code	Non ZBD: 1,2,~,8,9 / ZBD: A~Z
X	Source driver IC	Century=1, CLL=2, Demos=3, Epson=4, Fujitsu=5, Himax=6, Hitachi=7, Hynix=8, LDI=9, Matsushita=A, NEC=B, Novatec=C, OKI=D, Philips=E, Renesas=F, Samsung=G, Sanyo=H, Sharp=I, TI=J, Topro=K, Toshiba=L, Windbond=M
X	Gate driver IC code	
XX	Cell location	Tainan Taiwan=TN,
L	Cell line #	1,2,~,9,A,B,~,Y,Z
XX	Module location	Tainan Taiwan=TN ; Ningbo China=NP
L	Module line #	1,2,~,9,A,B,~,Y,Z
YMD	Year, month, day	Year: 2001=1, 2002=2, 2003=3, 2004=4... Month: 1~12=1, 2, 3, ~, 9, A, B, C Day: 1~31=1, 2, 3, ~, 9, A, B, C, ~, T, U, V
NNNN	Serial number	By LCD supplier

(e) UL Factory ID:

Region	Factory ID
TWCMO	GEMN
NBCMO	LEOO
NBCME	CANO
NHCMO	CAPG

10. RELIABILITY TEST

Environment test conditions are listed as following table.

Items	Required Condition	Note
Temperature Humidity Bias (THB)	Ta= 50 , 80%RH, 240hours	
High Temperature Operation (HTO)	Ta= 50 , 50%RH , 240hours	
Low Temperature Operation (LTO)	Ta= 0 , 240hours	
High Temperature Storage (HTS)	Ta= 60 , 240hours	
Low Temperature Storage (LTS)	Ta= -20 , 240hours	
Vibration Test (Non-operation)	Acceleration: 1.5 Grms Wave: Half-sine Frequency: 10 - 300 Hz Sweep: 30 Minutes each Axis (X, Y, Z)	
Shock Test (Non-operation)	Acceleration: 50 G Wave: Half-sine Active Time: 11 ms Direction : ± X, ± Y, ± Z.(one time for each Axis)	
Thermal Shock Test (TST)	-20 /30min , 60 / 30min , 100 cycles	
On/Off Test	25 , On/10sec , Off /10sec , 30,000 cycles	
ESD (Electro Static Discharge)	Contact Discharge: ± 8KV, 150pF(330Ω)	
	Air Discharge: ± 15KV, 150pF(330Ω)	
Altitude Test	Operation:10,000 ft / 24hours	
	Non-Operation:30,000 ft / 24hours	

11. PRECAUTIONS

11.1 ASSEMBLY AND HANDLING PRECAUTIONS

- (1) Do not apply rough force such as bending or twisting to the module during assembly.
- (2) To assemble or install module into user's system can be only in clean working areas. The dust and oil may cause electrical short or worsen the polarizer.
- (3) It's not permitted to have pressure or impulse on the module because the LCD panel and Backlight will be damaged.
- (4) Always follow the correct power sequence when LCD module is connecting and operating. This can prevent damage to the CMOS LSI chips during latch-up.
- (5) Do not pull the I/F connector in or out while the module is operating.
- (6) Do not disassemble the module.
- (7) Use a soft dry cloth without chemicals for cleaning, because the surface of polarizer is very soft and easily scratched.
- (8) It is dangerous that moisture come into or contacted the LCD module, because moisture may damage LCD module when it is operating.
- (9) High temperature or humidity may reduce the performance of module. Please store LCD module within the specified storage conditions.
- (10) When ambient temperature is lower than 10°C may reduce the display quality. For example, the response time will become slowly, and the starting voltage of CCFL will be higher than room temperature.

11.2 SAFETY PRECAUTIONS

- (1) The startup voltage of Backlight is approximately 1000 Volts. It may cause electrical shock while assembling with inverter. Do not disassemble the module or insert anything into the Backlight unit.
- (2) If the liquid crystal material leaks from the panel, it should be kept away from the eyes or mouth. In case of contact with hands, skin or clothes, it has to be washed away thoroughly with soap.
- (3) After the module's end of life, it is not harmful in case of normal operation and storage.

11.3 SAFETY STANDARDS

The LCD module should be certified with safety regulations as follows:

- (1) UL60950-1 or updated standard.
- (2) IEC60950-1 or updated standard.

11.4. Storage

- (1) Do not leave the module in high temperature, and high humidity for a long time.
It is highly recommended to store the module with temperature from 0 to 35
And relative humidity of less than 70%
- (2) Do not store the TFT – LCD module in direct sunlight
- (3) The module should be stored in dark place. It is prohibited to apply sunlight or fluorescent light in storing

11.5. Operation condition guide

- (1) The LCD product should be operated under normal condition.

Normal condition is defined as below :

Temperature : 20 ± 15

Humidity: $65\pm 20\%$

Display pattern : continually changing pattern(Not stationary)

- (2) If the product will be used in extreme conditions such as high temperature , high humidity , high altitude , display pattern or operation time etc...It is strongly recommended to contact CMO for application engineering advice . Otherwise , Its reliability and function may not be guaranteed.

11.6 OTHER

When fixed patterns are displayed for a long time, remnant image is likely to occur.

12. MECHANICAL CHARACTERISTICS

[Refer to the next 2 pages]

1 2 3 4 5 6 7 8 9 10 11 12 13 14 15 16

A

B

C

D

E

F

G

H

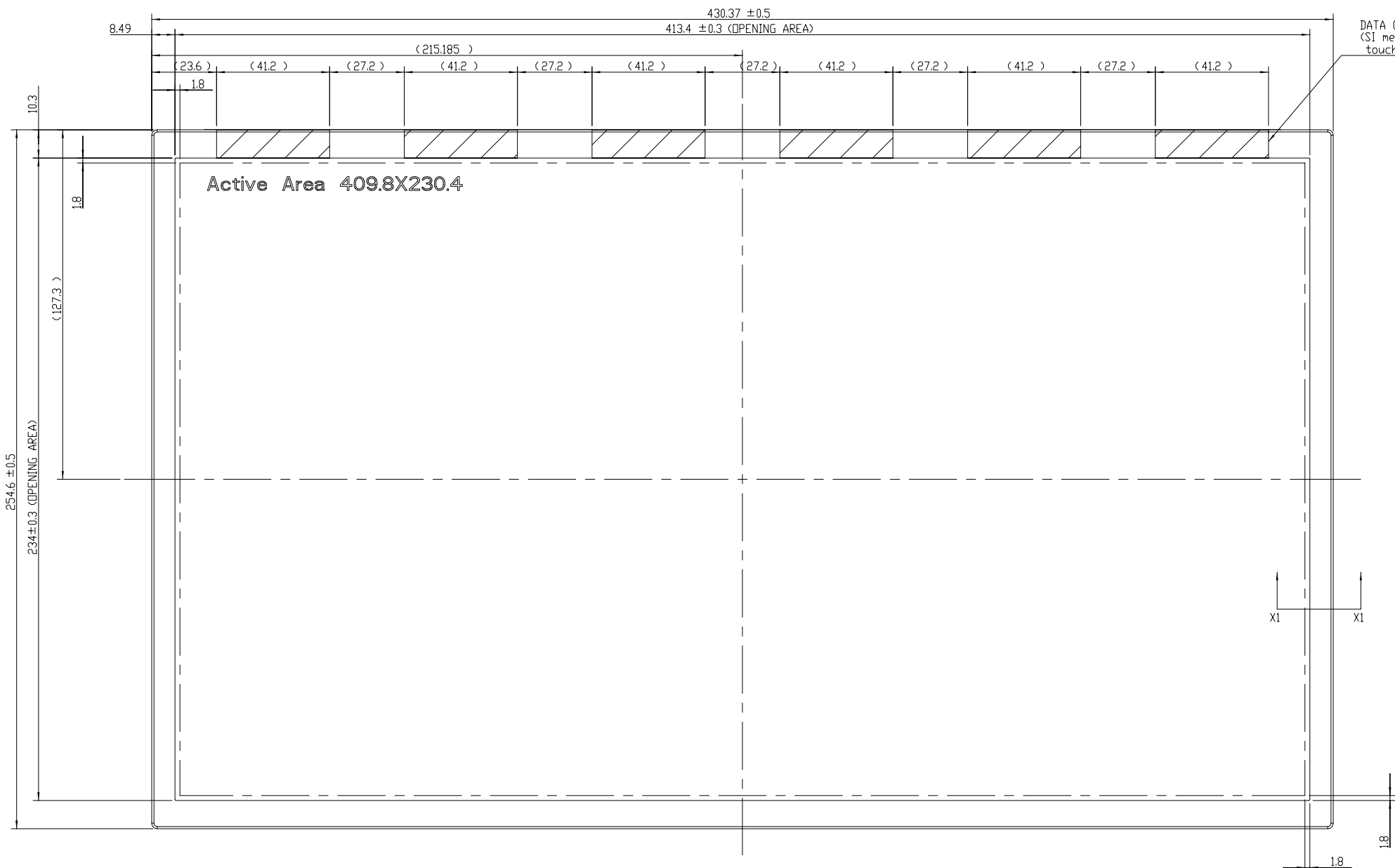
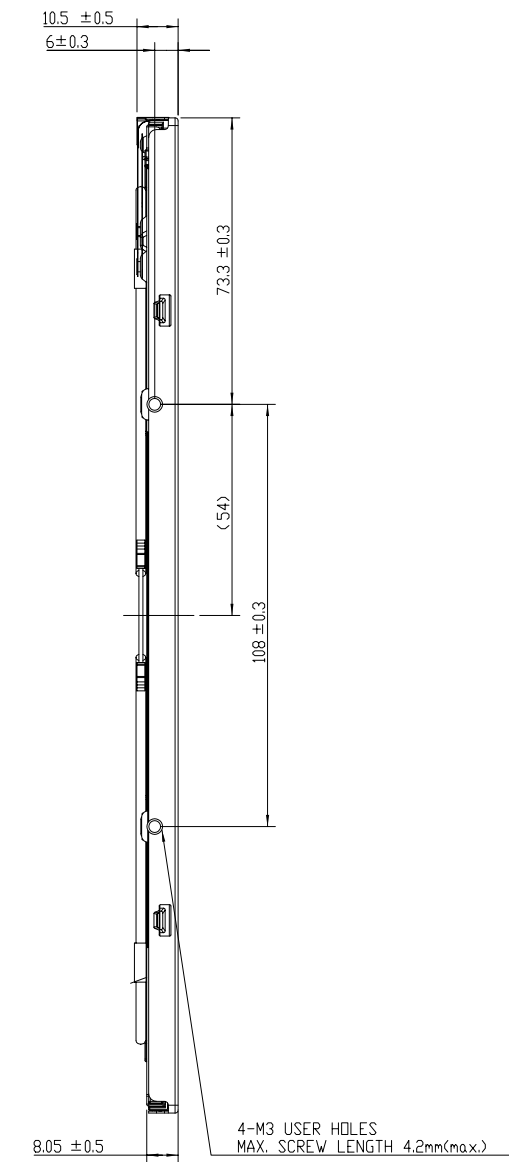

DATA CDF POSITION
(SI mechanical structure should not touch the positions of Data CDF)

DATA CDF POSITION
(SI mechanical structure should not touch the positions of Data CDF)

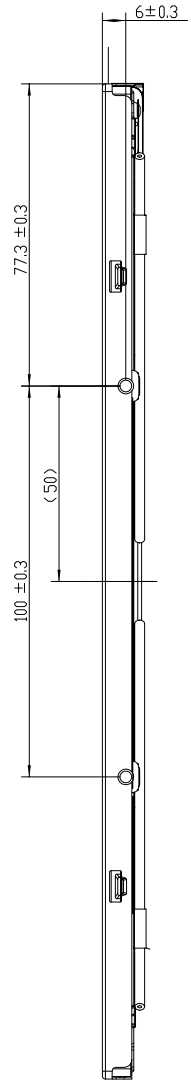

NOTES:
 1.UNSPECIFIED TOLERANCE:±0.5mm.
 2.DISPLAY AREA POSITION TOLERANCE : IA-BI <=1mm & IC-DI <=1mm
 3.I/F CONNECTOR SPEC: STARCONN 093G30-B2001A OR EQUIVALENT.
 4.LAMP CONNECTOR: YEONHD_LOCKING_TYPE 35001HS-02L OR EQUIVALENT.
 5.SIDE MOUNT HOLE TORQUE : 5kgf-cm (MAX.).

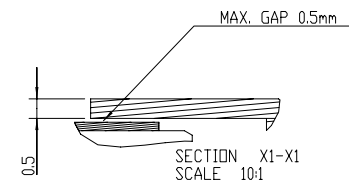
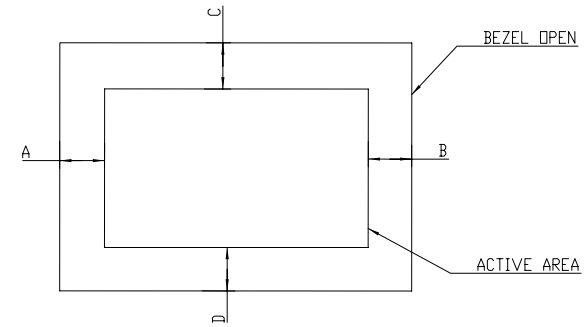

TITLE	ASSY_MODULE_M185B1-L07	ED REV. A
Approved	Yule_Lin	BD REV. 1.6
Checked	Alan_Lee	Part No. TBD
Drawer	Honglong Hsu	Material TBD
Designer	Honglong Hsu	Date 31-Aug-2009
		Scale 1:1
		Unitmm
		ALL RIGHTS RESERVED, COPYING FORBIDDEN.

Mark	Description	Date	Changed_By	Approved_By	ECN No.	Remark
1						
2						
3						
4						

1 2 3 4 5 6 7 8 9 10 11 12 13 14 15 16

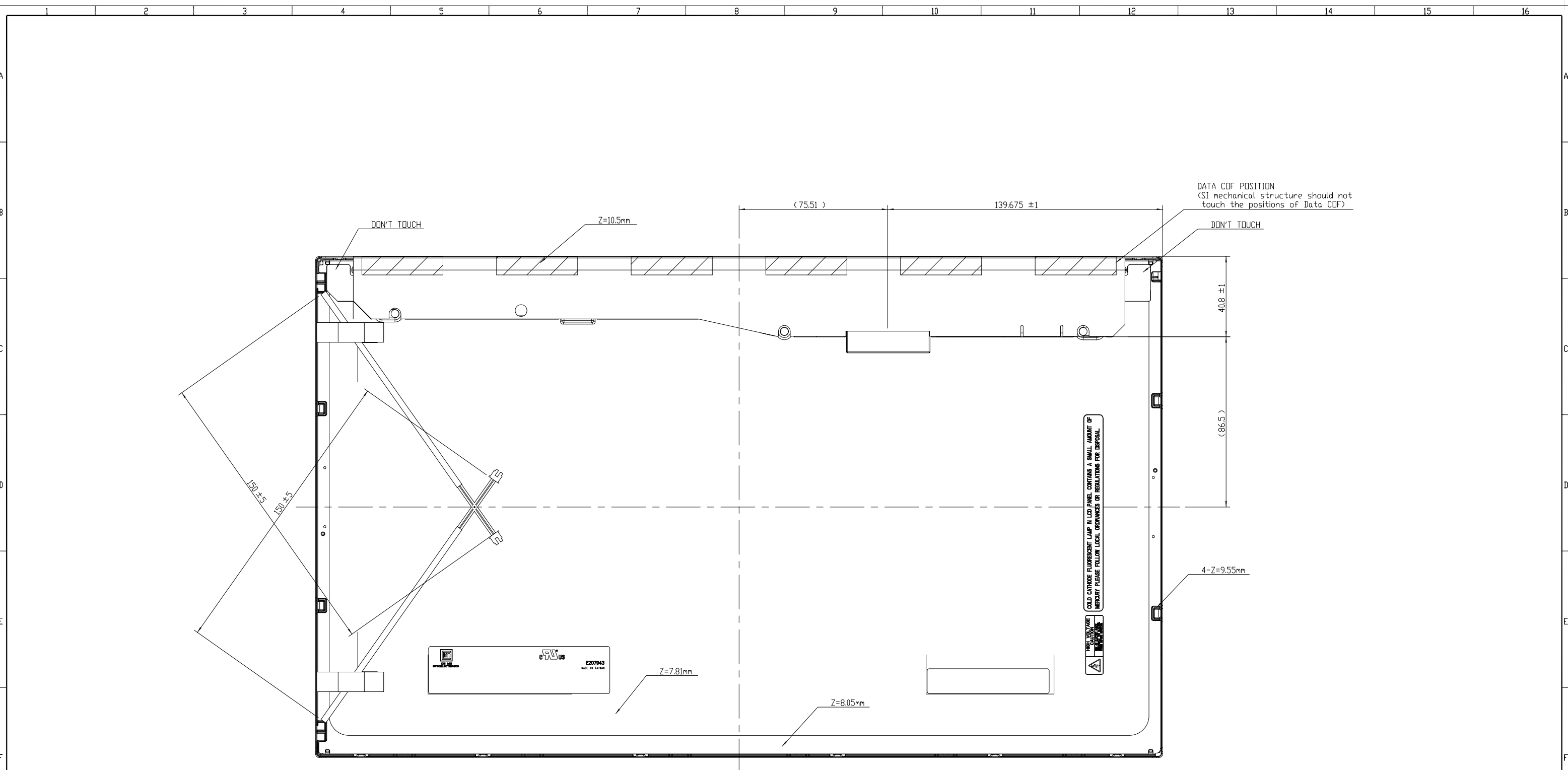

NOTES:
 1.UNSPECIFIED TOLERANCE:±0.5mm.
 2.I/F CONNECTOR SPEC: STARCONN 093G30-B2001A OR STM MSCKT2407P30HA.
 3.LAMP CONNECTOR: YEONHO_LOCKING_TYPE_35001HS-02L.
 4.SIDE MOUNT HOLE TORQUE : 5Kgf-cm(MAX.).

TITLE		ASSY_MODULE_M185B1-L07		ED REV. A	
Approved		Yule_Lin		BD REV. 1.6	
Checked		Alan_Lee		Drawing No. M18554101A	
Designer		Honglong Hsu		Part No. TBD	
Date		31-Aug-2009		Material TBD	
Scale		1:1		Sheet 2 / 2	
Unit		mm		A1	
		CHI MEI OPTOELECTRONICS CORP.		ALL RIGHTS RESERVED. COPYING FORBIDDEN.	

Mark	Description	Date	Changed_By	Approved_By	ECN No.	Remark
1						
2						
3						
4						