

## TFT LCD Approval Specification

# MODEL NO.: M185B3-P01

Customer: Orion

Approved by: \_\_\_\_\_

Note:

核准時間	部門	審核	角色	投票
2010-02-25 09:28:45	MTR 產品管理處		Director	Accept

## - CONTENTS -

REVISION HISTORY	3
1. GENERAL DESCRIPTION	4
1.1 OVERVIEW	
1.2 FEATURES	
1.3 APPLICATION	
1.4 GENERAL SPECIFICATIONS	
1.5 MECHANICAL SPECIFICATIONS	
2. ABSOLUTE MAXIMUM RATINGS	5
2.1 ABSOLUTE RATINGS OF ENVIRONMENT (BASED ON CMO MODULE M185B3-LA1)	
2.2 ABSOLUTE RATINGS OF ENVIRONMENT (OPEN CELL)	
2.3 ELECTRICAL ABSOLUTE RATINGS (OPEN CELL)	
3. ELECTRICAL CHARACTERISTICS	7
3.1 TFT LCD OPEN CELL	
3.2 V <sub>cc</sub> POWER DIP CONDITION	
4. BLOCK DIAGRAM	9
4.1 TFT LCD OPEN CELL	
5. INPUT TERMINAL PIN ASSIGNMENT	10
5.1 TFT LCD MODULE	
5.2 LVDS DATA MAPPING TABLE	
5.3 COLOR DATA INPUT ASSIGNMENT	
6. INTERFACE TIMING	13
6.1 INPUT SIGNAL TIMING SPECIFICATIONS	
6.2 POWER ON/OFF SEQUENCE	
7. OPTICAL CHARACTERISTICS	16
7.1 TEST CONDITIONS	
7.2 OPTICAL SPECIFICATIONS	
7.3 FLICKER ADJUSTMENT	
8. PACKAGING	21
8.1 PACKING SPECIFICATIONS	
8.2 PACKING METHOD	
9. DEFINITION OF LABELS	22
9.1 OPEN CELL LABEL	
9.2 CARTON LABEL	
10. RELIABILITY TEST	23
11. PRECAUTIONS	24
11.1 ASSEMBLY AND HANDLING PRECAUTIONS	
11.2 SAFETY PRECAUTIONS	
11.3 OTHERS	
12. MECHANICAL DRAWING	25



REVISION HISTORY

Version	Date	Section	Description
Ver 3.0	Feb, 23, 10'	All	M185B3-P01 Approval Specification was first issued.

## 1. GENERAL DESCRIPTION

### 1.1 OVERVIEW

The M185B3-P01 is a 18.5" TFT LCD cell with driver ICs and a 30-pins-1ch-LVDS circuit board.

The product supports 1366 x 768 WXGA mode and can display up to 16.7M colors. The backlight unit is not built in.

### 1.2 FEATURES

- Contrast ratio 1000:1
- Response time 5ms.
- WXGA (1366 x 768 pixels) resolution.
- DE (Data Enable) only mode.
- LVDS (Low Voltage Differential Signaling) interface.
- RoHS compliance.

### 1.3 APPLICATION

- TFT LCD Monitor
- TFT LCD TV

### 1.4 GENERAL SPECIFICATIONS

Item	Specification	Unit	Note
Diagonal Size	18.5	inch	-
Active Area	409.8 (H) x 230.4 (V)	mm	(1)
Driver Element	a-si TFT active matrix	-	-
Pixel Number	1366 x R.G.B. x 768	pixel	-
Pixel Pitch	0.3 (H) x 0.3 (V)	mm	-
Pixel Arrangement	RGB vertical stripe	-	-
Display Colors	16.7M	color	-
Transmissive Mode	Normally White	-	-
Surface Treatment	Hard coating (3H), Anti-glare (Haze 25%)	-	-
Power Consumption	3.0	Watt	(3)

### 1.5 MECHANICAL SPECIFICATIONS

Item	Min.	Typ.	Max.	Unit	Note
Weight	-	415	435	g	-
I/F connector mounting position	The mounting inclination of the connector makes the screen center within $\pm 0.5\text{mm}$ as the horizontal.			-	(2)

Note (1) Please refer to the attached drawings for more information of front and back outline dimensions.

(2) Connector mounting position

(3) Please refer to sec.3.1 for more information of power consumption.

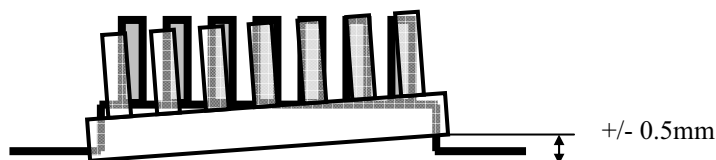

## 2. ABSOLUTE MAXIMUM RATINGS

### 2.1 ABSOLUTE RATINGS OF ENVIRONMENT (BASED ON CMO MODULE M185B3-LA1)

Item	Symbol	Value		Unit	Note
		Min.	Max.		
Storage Temperature	$T_{ST}$	-20	+60	°C	(1)
Operating Ambient Temperature	$T_{OP}$	0	+50	°C	(1), (2)

Note (1) Temperature and relative humidity range is shown in the figure below.

- (a) 90 %RH Max. ( $T_a \leq 40$  °C).
- (b) Wet-bulb temperature should be 39 °C Max. ( $T_a > 40$  °C).
- (c) No condensation.

Note (2) The temperature of panel display surface area should be 0 °C Min. and 60 °C Max.

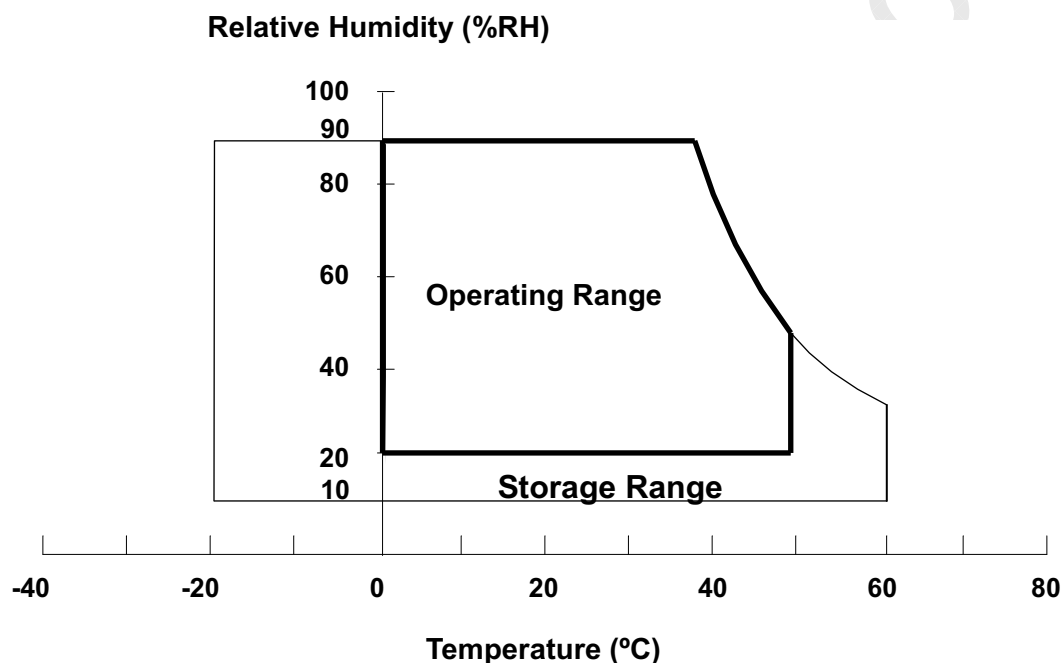

## 2.2 ABSOLUTE RATINGS OF ENVIRONMENT (OPEN CELL)

High temperature or humidity may reduce the performance of panel. Please store LCD panel within the specified storage conditions.

Storage Condition: With packing.

Storage temperature range: 25±5 °C.

Storage humidity range: 50±10%RH.

Shelf life: 30days

## 2.3 ELECTRICAL ABSOLUTE RATINGS (OPEN CELL)

Item	Symbol	Value		Unit	Note
		Min	Max		
Power Supply Voltage	V <sub>CC</sub>	-0.3	+6.0	V	(1)
Logic Input Voltage	V <sub>logic</sub>	-0.3	2.7	V	-

Note (1) Permanent damage might occur if the module is operated at conditions exceeding the maximum values.

### 3. ELECTRICAL CHARACTERISTICS

#### 3.1 TFT LCD OPEN CELL

 $T_a = 25 \pm 2 \text{ }^\circ\text{C}$ 

Parameter	Symbol	Value			Unit	Note
		Min.	Typ.	Max.		
Power Supply Voltage	V <sub>CC</sub>	4.5	5.0	5.5	V	-
Ripple Voltage	V <sub>RP</sub>	-	-	300	mV	-
Power On Rush Current	I <sub>RUSH</sub>	-	-	3	A	(2)
Power Supply Current	White	-	0.41	0.54	A	(3)a
	Black	-	0.57	0.76	A	(3)b
	Vertical Stripe	-	0.6	0.8	A	(3)c
Power Consumption	P <sub>LCD</sub>	-	3.0	4.0	Watt	(4)
LVDS differential input voltage	V <sub>id</sub>	200	-	600	mV	(5)
LVDS common input voltage	V <sub>ic</sub>	1.0	1.2	1.4	V	-
Logic High Input Voltage	V <sub>IH</sub>	2.0	-	2.7	V	-
Logic Low Input Voltage	V <sub>IL</sub>	-	-	0.5	V	-

Note (1) The module should be always operated within above ranges.

Note (2) Power On Rush Current Measurement Conditions: (must follow power sequence)

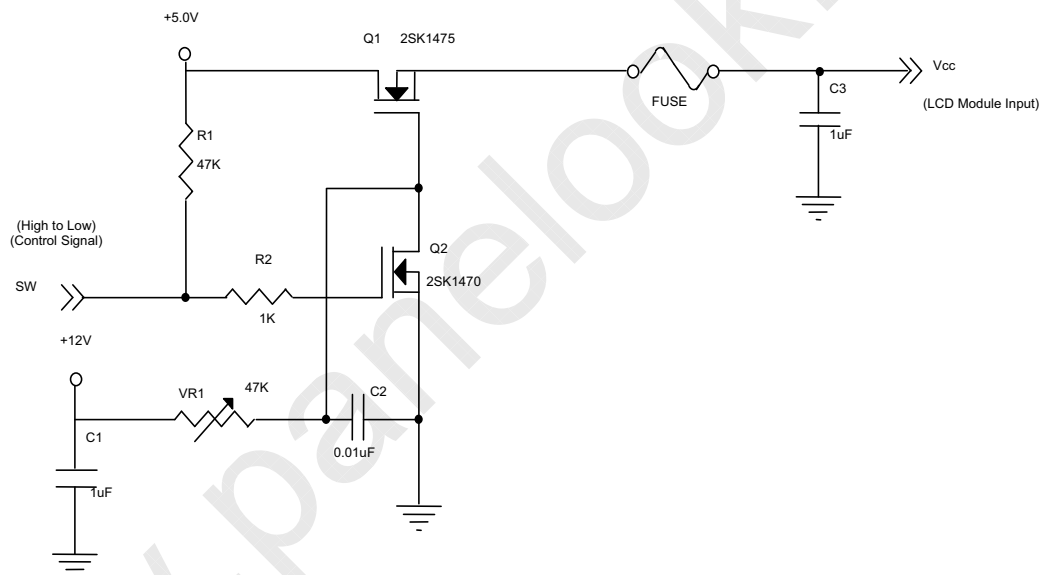

**Vcc rising time is 470μs**

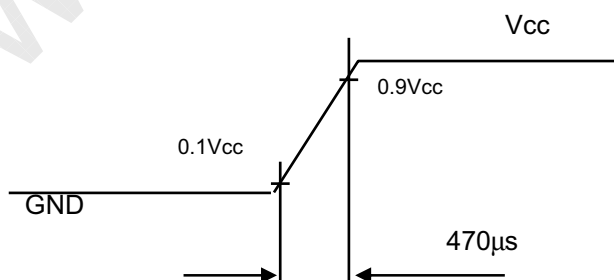

Note (3) The specified power supply current is under the conditions at  $V_{cc} = 5.0\text{ V}$ ,  $T_a = 25 \pm 2\text{ }^\circ\text{C}$ ,  $F_v = 60\text{ Hz}$ , whereas a power dissipation check pattern below is displayed.

a. White Pattern

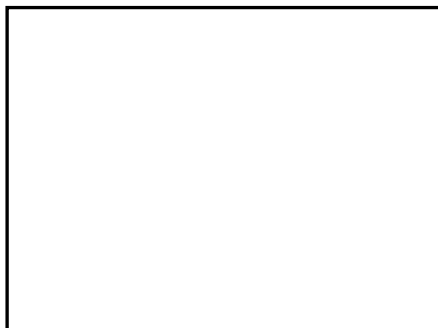

Active Area

b. Black Pattern



Active Area

c. Vertical Stripe Pattern

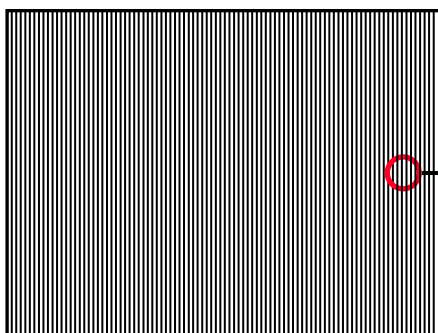

Active Area

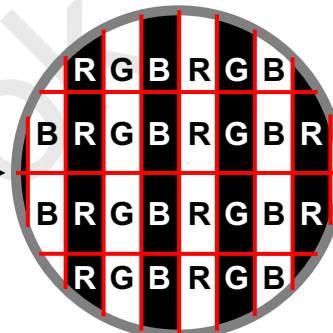

Note (4) The power consumption is specified at the pattern with the maximum current.

Note (5) VID waveform condition

Single-End

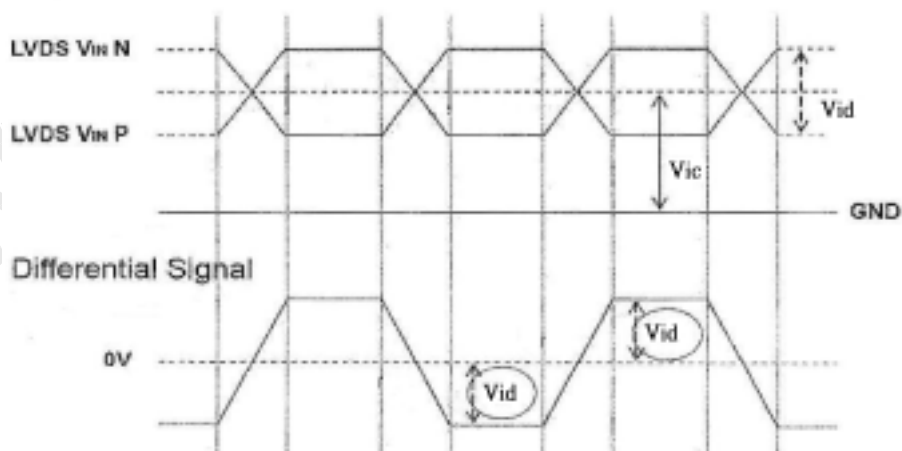

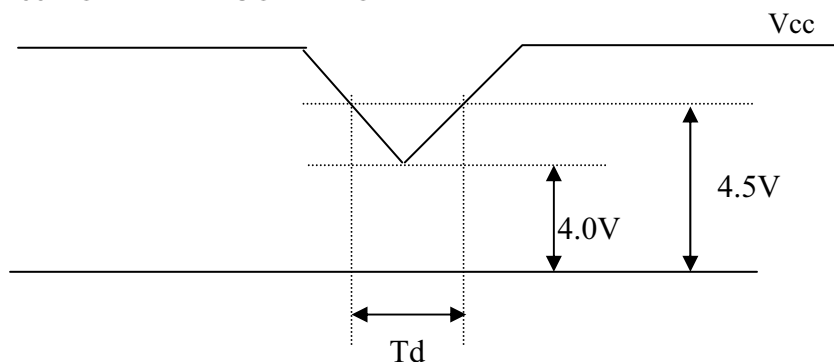

3.2 V<sub>cc</sub> POWER DIP CONDITION:

Dip condition:  $4.0V \leq V_{cc} \leq 4.5V, T_d \leq 20ms$

## 4. BLOCK DIAGRAM

## 4.1 TFT LCD OPEN CELL

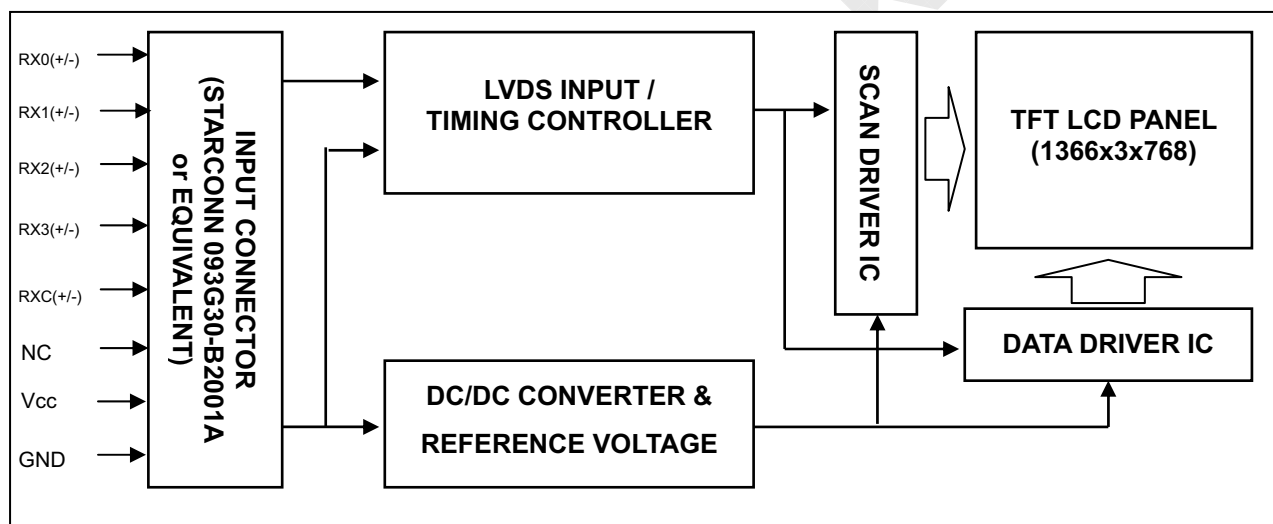

## 5. INPUT TERMINAL PIN ASSIGNMENT

### 5.1 TFT LCD MODULE

Pin	Name	Description
1	NC	Not connection, this pin should be open.
2	NC	Not connection, this pin should be open.
3	NC	Not connection, this pin should be open.
4	GND	Ground
5	RX0-	Negative LVDS differential data input. Channel 0
6	RX0+	Positive LVDS differential data input. Channel 0
7	GND	Ground
8	RX1-	Negative LVDS differential data input. Channel 1
9	RX1+	Positive LVDS differential data input. Channel 1
10	GND	Ground
11	RX2-	Negative LVDS differential data input. Channel 2
12	RX2+	Positive LVDS differential data input. Channel 2
13	GND	Ground
14	RXCLK-	Negative LVDS differential clock input.
15	RXCLK+	Positive LVDS differential clock input.
16	GND	Ground
17	RX3-	Negative LVDS differential data input. Channel 3
18	RX3+	Positive LVDS differential data input. Channel 3
19	GND	Ground
20	NC	Not connection, this pin should be open.
21	NC	Not connection, this pin should be open.
22	NC	For LCD internal use only, Do not connect
23	GND	Ground
24	GND	Ground
25	GND	Ground
26	Vcc	+5.0V power supply
27	Vcc	+5.0V power supply
28	Vcc	+5.0V power supply
29	Vcc	+5.0V power supply
30	Vcc	+5.0V power supply

Note (1) Connector Part No.: STARCONN 093G30-B2001A or equivalent.



## 5.2 LVDS DATA MAPPING TABLE

LVDS Channel 0	LVDS output	D7	D6	D4	D3	D2	D1	D0
	Data order	G0	R5	R4	R3	R2	R1	R0
LVDS Channel 1	LVDS output	D18	D15	D14	D13	D12	D9	D8
	Data order	B1	B0	G5	G4	G3	G2	G1
LVDS Channel 2	LVDS output	D26	D25	D24	D22	D21	D20	D19
	Data order	DE	NA	NA	B5	B4	B3	B2
LVDS Channel 3	LVDS output	D23	D17	D16	D11	D10	D5	D27
	Data order	NA	B7	B6	G7	G6	R7	R6



**Approval**

### 5.3 COLOR DATA INPUT ASSIGNMENT

The brightness of each primary color (red, green and blue) is based on the 8-bit gray scale data input for the color. The higher the binary input, the brighter the color. The table below provides the assignment of color versus data input.

Color		Data Signal																							
		Red								Green						Blue									
		R7	R6	R5	R4	R3	R2	R1	R0	R7	R6	G5	G4	G3	G2	G1	G0	R7	R6	B5	B4	B3	B2	B1	B0
Basic Colors	Black	0	0	0	0	0	0	0	0	0	0	0	0	0	0	0	0	0	0	0	0	0	0	0	0
	Red	1	1	1	1	1	1	1	1	0	0	0	0	0	0	0	0	0	0	0	0	0	0	0	0
	Green	0	0	0	0	0	0	0	0	1	1	1	1	1	1	1	1	0	0	0	0	0	0	0	0
	Blue	0	0	0	0	0	0	0	0	0	0	0	0	0	0	0	0	1	1	1	1	1	1	1	1
	Cyan	0	0	0	0	0	0	0	0	1	1	1	1	1	1	1	1	1	1	1	1	1	1	1	1
	Magenta	1	1	1	1	1	1	1	1	0	0	0	0	0	0	0	0	1	1	1	1	1	1	1	1
	Yellow	1	1	1	1	1	1	1	1	1	1	1	1	1	1	1	1	0	0	0	0	0	0	0	0
	White	1	1	1	1	1	1	1	1	1	1	1	1	1	1	1	1	1	1	1	1	1	1	1	1
Gray Scale Of Red	Red(0) / Dark	0	0	0	0	0	0	0	0	0	0	0	0	0	0	0	0	0	0	0	0	0	0	0	0
	Red(1)	0	0	0	0	0	0	0	1	0	0	0	0	0	0	0	0	0	0	0	0	0	0	0	0
	Red(2)	0	0	0	0	0	0	1	0	0	0	0	0	0	0	0	0	0	0	0	0	0	0	0	0
	⋮	⋮	⋮	⋮	⋮	⋮	⋮	⋮	⋮	⋮	⋮	⋮	⋮	⋮	⋮	⋮	⋮	⋮	⋮	⋮	⋮	⋮	⋮	⋮	⋮
	⋮	⋮	⋮	⋮	⋮	⋮	⋮	⋮	⋮	⋮	⋮	⋮	⋮	⋮	⋮	⋮	⋮	⋮	⋮	⋮	⋮	⋮	⋮	⋮	⋮
	⋮	⋮	⋮	⋮	⋮	⋮	⋮	⋮	⋮	⋮	⋮	⋮	⋮	⋮	⋮	⋮	⋮	⋮	⋮	⋮	⋮	⋮	⋮	⋮	⋮
	Red(253)	1	1	1	1	1	1	0	1	0	0	0	0	0	0	0	0	0	0	0	0	0	0	0	0
	Red(254)	1	1	1	1	1	1	0	0	0	0	0	0	0	0	0	0	0	0	0	0	0	0	0	0
Red(255)	1	1	1	1	1	1	1	0	0	0	0	0	0	0	0	0	0	0	0	0	0	0	0	0	
Gray Scale Of Green	Green(0) / Dark	0	0	0	0	0	0	0	0	0	0	0	0	0	0	0	0	0	0	0	0	0	0	0	0
	Green(1)	0	0	0	0	0	0	0	0	0	0	0	0	0	0	1	0	0	0	0	0	0	0	0	
	Green(2)	0	0	0	0	0	0	0	0	0	0	0	0	0	1	0	0	0	0	0	0	0	0	0	
	⋮	⋮	⋮	⋮	⋮	⋮	⋮	⋮	⋮	⋮	⋮	⋮	⋮	⋮	⋮	⋮	⋮	⋮	⋮	⋮	⋮	⋮	⋮	⋮	
	⋮	⋮	⋮	⋮	⋮	⋮	⋮	⋮	⋮	⋮	⋮	⋮	⋮	⋮	⋮	⋮	⋮	⋮	⋮	⋮	⋮	⋮	⋮	⋮	
	⋮	⋮	⋮	⋮	⋮	⋮	⋮	⋮	⋮	⋮	⋮	⋮	⋮	⋮	⋮	⋮	⋮	⋮	⋮	⋮	⋮	⋮	⋮	⋮	
	Green(253)	0	0	0	0	0	0	0	1	1	1	1	1	1	1	0	1	0	0	0	0	0	0	0	
	Green(254)	0	0	0	0	0	0	0	1	1	1	1	1	1	1	0	0	0	0	0	0	0	0	0	
Green(255)	0	0	0	0	0	0	0	1	1	1	1	1	1	1	1	0	0	0	0	0	0	0	0		
Gray Scale Of Blue	Blue(0) / Dark	0	0	0	0	0	0	0	0	0	0	0	0	0	0	0	0	0	0	0	0	0	0	0	0
	Blue(1)	0	0	0	0	0	0	0	0	0	0	0	0	0	0	0	0	0	0	0	0	0	0	0	1
	Blue(2)	0	0	0	0	0	0	0	0	0	0	0	0	0	0	0	0	0	0	0	0	0	0	1	0
	⋮	⋮	⋮	⋮	⋮	⋮	⋮	⋮	⋮	⋮	⋮	⋮	⋮	⋮	⋮	⋮	⋮	⋮	⋮	⋮	⋮	⋮	⋮	⋮	⋮
	⋮	⋮	⋮	⋮	⋮	⋮	⋮	⋮	⋮	⋮	⋮	⋮	⋮	⋮	⋮	⋮	⋮	⋮	⋮	⋮	⋮	⋮	⋮	⋮	⋮
	⋮	⋮	⋮	⋮	⋮	⋮	⋮	⋮	⋮	⋮	⋮	⋮	⋮	⋮	⋮	⋮	⋮	⋮	⋮	⋮	⋮	⋮	⋮	⋮	⋮
	Blue(253)	0	0	0	0	0	0	0	0	0	0	0	0	0	0	0	0	1	1	1	1	1	1	0	1
	Blue(254)	0	0	0	0	0	0	0	0	0	0	0	0	0	0	0	0	1	1	1	1	1	1	1	0
Blue(255)	0	0	0	0	0	0	0	0	0	0	0	0	0	0	0	0	1	1	1	1	1	1	1	1	

Note (1) 0: Low Level Voltage, 1: High Level Voltage

## 6. INTERFACE TIMING

### 6.1 INPUT SIGNAL TIMING SPECIFICATIONS

The input signal timing specifications are shown as the following table and timing diagram

Signal	Item	Symbol	Min.	Typ.	Max.	Unit	Note
LVDS Clock	Frequency	$F_c$	60	76	96	MHz	-
	Period	$T_c$	-	13.0	-	ns	-
	Input cycle to cycle jitter	$T_{rcj}$	-	-	200	ps	(1)
	Spread spectrum modulation range	$F_{clk_{in\_mod}}$	$F_c * 98\%$	-	$F_c * 102\%$	MHz	(2)
	Spread spectrum modulation frequency	$F_{SSM}$	-	-	200	KHz	
	High Time	$T_{ch}$	-	4/7	-	$T_c$	-
	Low Time	$T_{cl}$	-	3/7	-	$T_c$	-
LVDS Data	Setup Time	$T_{lvs}$	600	-	-	ps	(3)
	Hold Time	$T_{lvh}$	600	-	-	ps	
Vertical Active Display Term	Frame Rate	$F_v$	50	60	75	Hz	-
	Total	$T_v$	790	806	850	$T_h$	$T_v = T_{vd} + T_{vb}$
	Display	$T_{vd}$	768	768	768	$T_h$	-
	Blank	$T_{vb}$	$T_v - T_{vd}$	38	$T_v - T_{vd}$	$T_h$	-
Horizontal Active Display Term	Total	$T_h$	1490	1560	1580	$T_c$	$T_h = T_{hd} + T_{hb}$
	Display	$T_{hd}$	1366	1366	1366	$T_c$	-
	Blank	$T_{hb}$	$T_h - T_{hd}$	194	$T_h - T_{hd}$	$T_c$	-

Note: Because this module is operated by DE only mode, Hsync and Vsync input signals are ignored.

### INPUT SIGNAL TIMING DIAGRAM

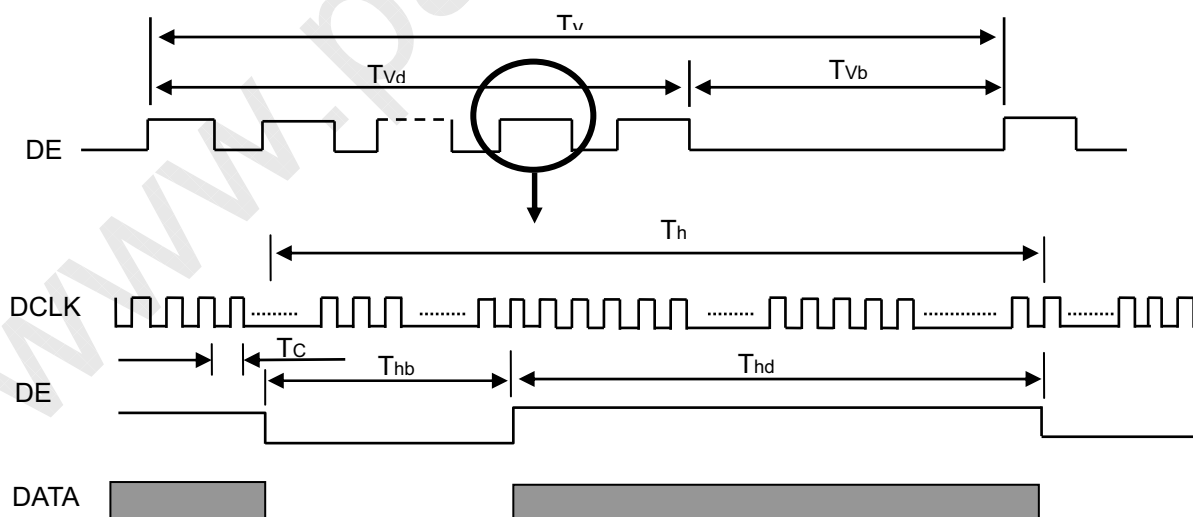

Note (1) The input clock cycle-to-cycle jitter is defined as below figures.  $Trcl = |T_1 - T_1|$

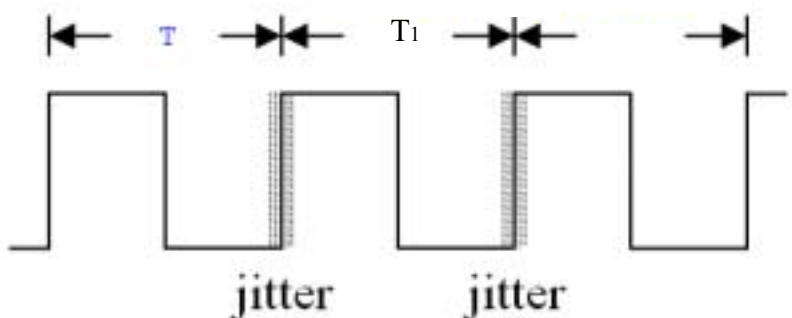

Note (2) The SSCG (Spread spectrum clock generator) is defined as below figures.

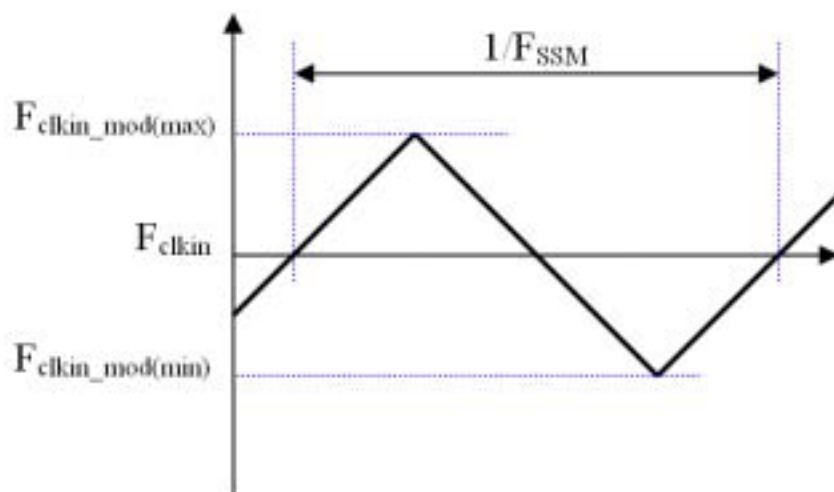

Note (3) The LVDS timing diagram and setup/hold time is defined and showing as the following figures.

### LVDS RECEIVER INTERFACE TIMING DIAGRAM

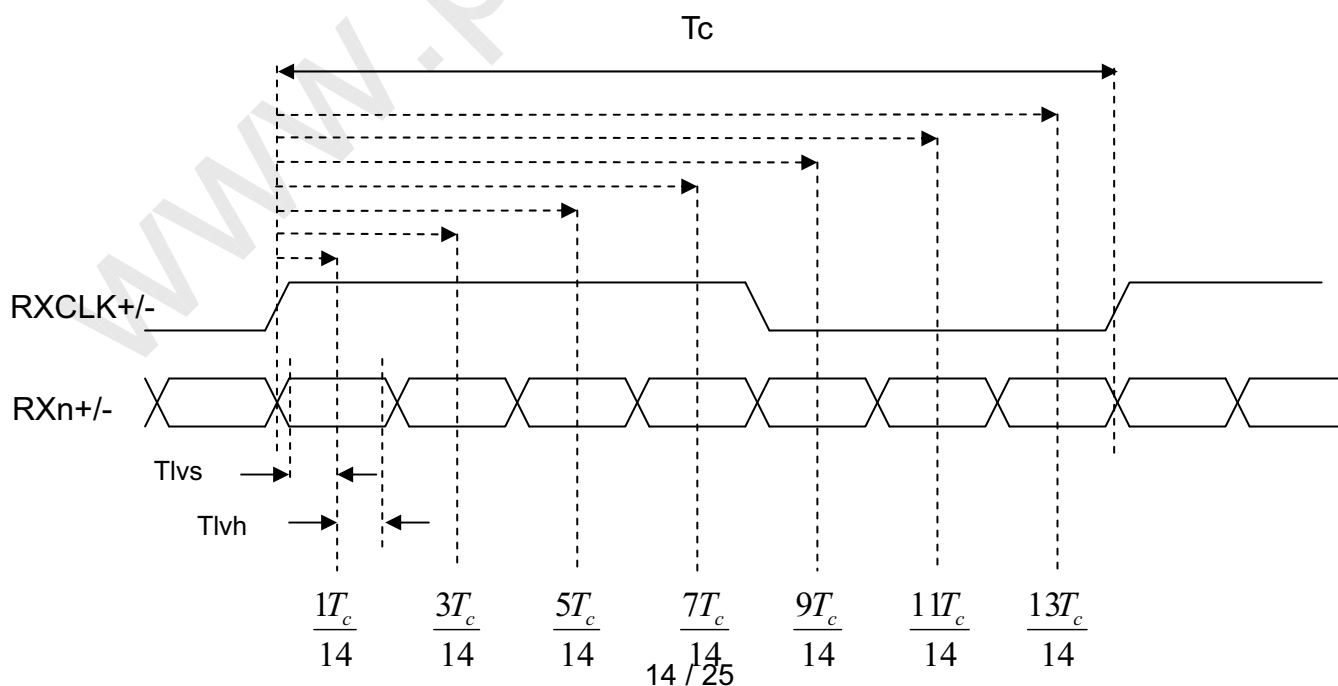

## 6.2 POWER ON/OFF SEQUENCE

To prevent a latch-up or DC operation of LCD module, the power on/off sequence should be as the diagram below.

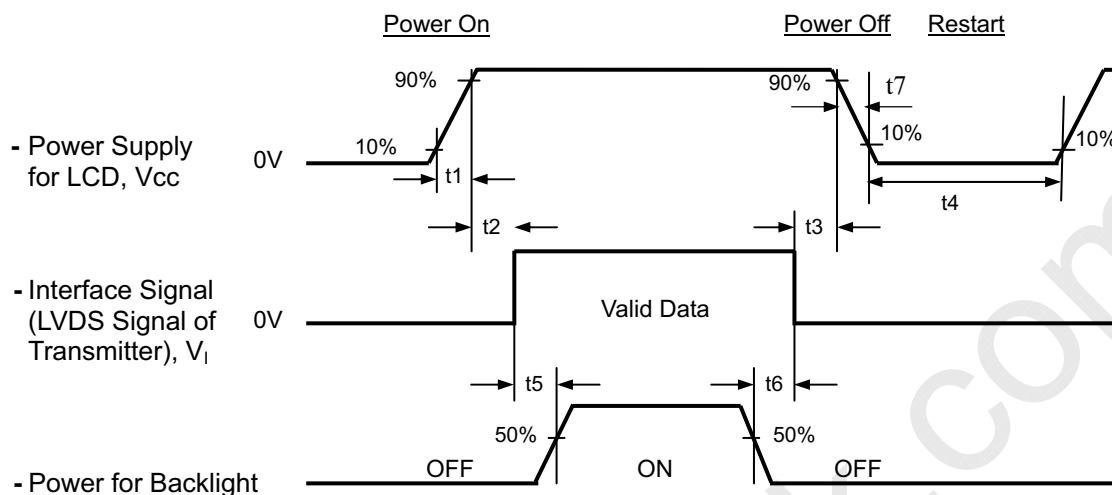

### Timing Specifications:

- $0.5 < t_1 \leq 5 \text{ msec}$
- $0 < t_2 \leq 50 \text{ msec}$
- $0 < t_3 \leq 50 \text{ msec}$
- $t_4 \geq 500 \text{ msec}$
- $t_5 \geq 450 \text{ msec}$
- $t_6 \geq 90 \text{ msec}$
- $5 \leq t_7 \leq 100 \text{ msec}$

### Note.

- (1) The supply voltage of the external system for the module input should be the same as the definition of V<sub>cc</sub>.
- (2) When the backlight turns on before the LCD operation of the LCD turns off, the display may momentarily become abnormal screen.
- (3) In case of V<sub>CC</sub> = off level, please keep the level of input signals on the low or keep a high impedance.
- (4) T<sub>4</sub> should be measured after the module has been fully discharged between power off and on period.
- (5) Interface signal shall not be kept at high impedance when the power is on.
- (6) It is not guaranteed that products are damaged which is caused by not following the Power Sequence.
- (7) It is suggested that V<sub>cc</sub> falling time follows t<sub>7</sub> specification, else slight noise is likely to occur when LCD is turned off (even backlight is already off).

## 7. OPTICAL CHARACTERISTICS

### 7.1 TEST CONDITIONS

Item	Symbol	Value	Unit
Ambient Temperature	Ta	25±2	°C
Ambient Humidity	Ha	50±10	%RH
Supply Voltage	V <sub>CC</sub>	5.0	V
Input Signal	According to typical value in "3. ELECTRICAL CHARACTERISTICS"		
Inverter Current	I <sub>L</sub>	7.0±0.5	mA
Inverter Driving Frequency	F <sub>L</sub>	55±5	KHz

### 7.2 OPTICAL SPECIFICATIONS

The relative measurement methods of optical characteristics are shown as below. The following items should be measured under the test conditions described in 7.1 and stable environment shown in Note (6).

Item	Symbol	Condition	Min.	Typ.	Max.	Unit	Note				
Color Chromaticity	Red	$\theta_x=0^\circ, \theta_y=0^\circ$ DMS 803	Typ - -0.03	Typ + 0.03			(0),(7)	Rcx	0.645	-	
								Rcy	0.328	-	
	Green							Gcx	0.275	-	
								Gcy	0.580	-	
	Blue							Bcx	0.148	-	
								Bcy	0.105	-	
	White							Wcx	0.322	-	
								Wcy	0.351	-	
Center Transmittance	T%	$\theta_x=0^\circ, \theta_y=0^\circ$	5.4	6.0	-	%	(1), (5)				
Contrast Ratio	CR	CS-2000, CMO BLU	700	1000	-	-	(1), (3)				
Response Time	T <sub>R</sub>	$\theta_x=0^\circ, \theta_y=0^\circ$					(4)	-	1.3	2.2	ms
	T <sub>F</sub>							-	3.7	5.8	ms
Transmittance uniformity	$\delta T$	$\theta_x=0^\circ, \theta_y=0^\circ$ USB-2000	-	--	1.42	-	(1), (8)				
Viewing Angle	Horizontal	$\theta_{x+}+\theta_{x-}$	CR>10	150	170	---	Deg.	(1), (2) (6)			
	Vertical	$\theta_{y+}+\theta_{y-}$	USB-2000	140	160	---					
	Horizontal	$\theta_{x+}+\theta_{x-}$	CR> 5	160	178	---	Deg.	(1), (2) (6)			
	Vertical	$\theta_{y+}+\theta_{y-}$	USB-2000	150	170	---					



### 7.3 FLICKER ADJUSTMENT

Flicker must be finely adjusted after module assembling and aging. Please follow the instructions below.

(1) Adjustment Pattern: 2H1V checker pattern as follows.

R	G	B	R	G	B	R	G	B	R	G	B	R	G	B	R	G	B	R	G	B	R	G	B
R	G	B	R	G	B	R	G	B	R	G	B	R	G	B	R	G	B	R	G	B	R	G	B
R	G	B	R	G	B	R	G	B	R	G	B	R	G	B	R	G	B	R	G	B	R	G	B
R	G	B	R	G	B	R	G	B	R	G	B	R	G	B	R	G	B	R	G	B	R	G	B
R	G	B	R	G	B	R	G	B	R	G	B	R	G	B	R	G	B	R	G	B	R	G	B
R	G	B	R	G	B	R	G	B	R	G	B	R	G	B	R	G	B	R	G	B	R	G	B
R	G	B	R	G	B	R	G	B	R	G	B	R	G	B	R	G	B	R	G	B	R	G	B
R	G	B	R	G	B	R	G	B	R	G	B	R	G	B	R	G	B	R	G	B	R	G	B



(2) Adjustment Method:

Flicker should be adjusted by turning the volume for flicker adjustment by the ceramic driver. It is adjusted to the point with least flickering of the whole screen. After making it surely overrun at once, it should be adjusted to the optimum point.

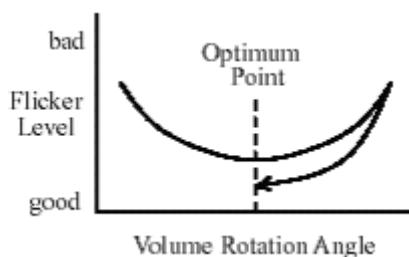

Note (0) Light source is the standard light source "C" which is defined by CIE and driving voltages are based on suitable gamma voltages

Note (1) Light source is the BLU, which is supplied by CMO, and driving voltages are based on suitable gamma voltages. White is without signal input and R, G, B are with signal input. SPEC is judged by CMO's golden sample

Note (2) Definition of Viewing Angle ( $\theta_x$ ,  $\theta_y$ ):

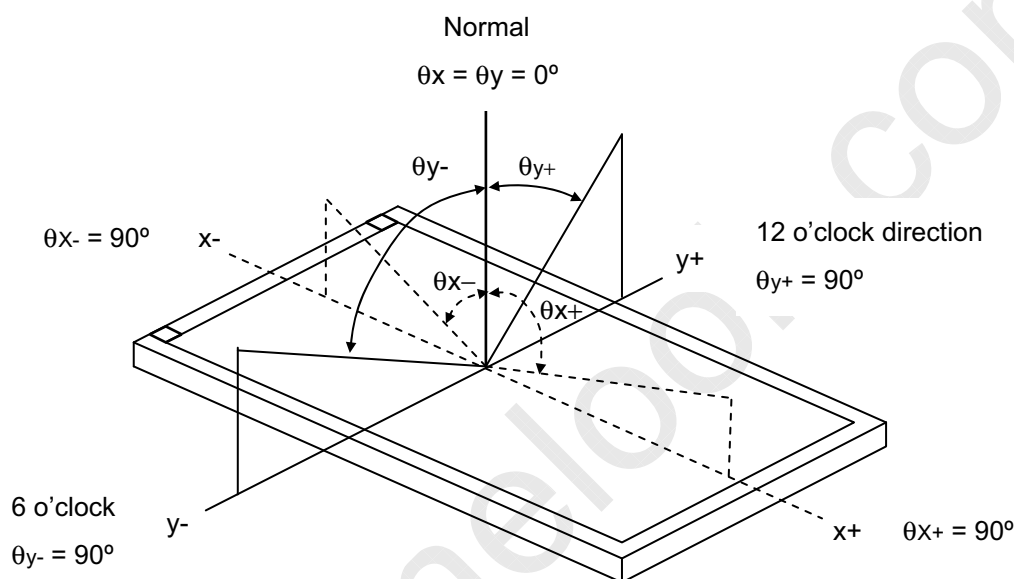

Note (3) Definition of Contrast Ratio (CR):

The contrast ratio can be calculated by the following expression.

$$\text{Contrast Ratio (CR)} = L_{255} / L_0$$

L255: Luminance of gray level 255

L 0: Luminance of gray level 0

$$CR = CR(5)$$

CR (X) is corresponding to the Contrast Ratio of the point X at Figure in Note (8).

Note (4) Definition of Response Time ( $T_R$ ,  $T_F$ ):

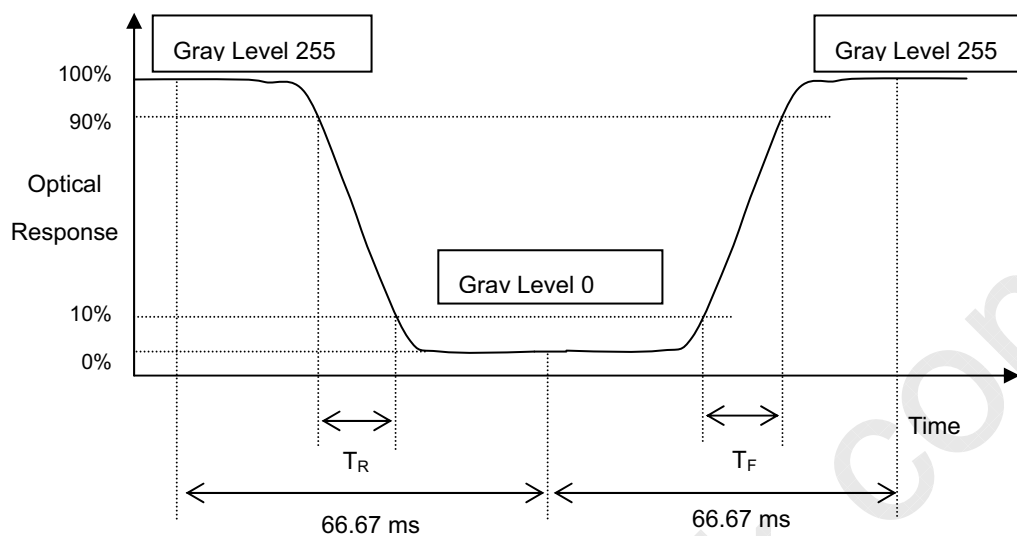

Note (5) Definition of Transmittance ( $T\%$ ):

Module is without signal input.

$$\text{Transmittance} = \frac{\text{Luminance of LCD module } L(5)}{\text{Luminance of backlight } L_{BLU}(5)} * 100\%$$

$L(X)$  and  $L_{BLU}(X)$  is corresponding to the luminance of the point X at Figure in Note (8).

Note (6) Measurement Setup:

The LCD module should be stabilized at given temperature for 20minutes to avoid abrupt temperature change during measuring. In order to stabilize the luminance, the measurement should be executed after lighting Backlight for 20minutes in a windless room.

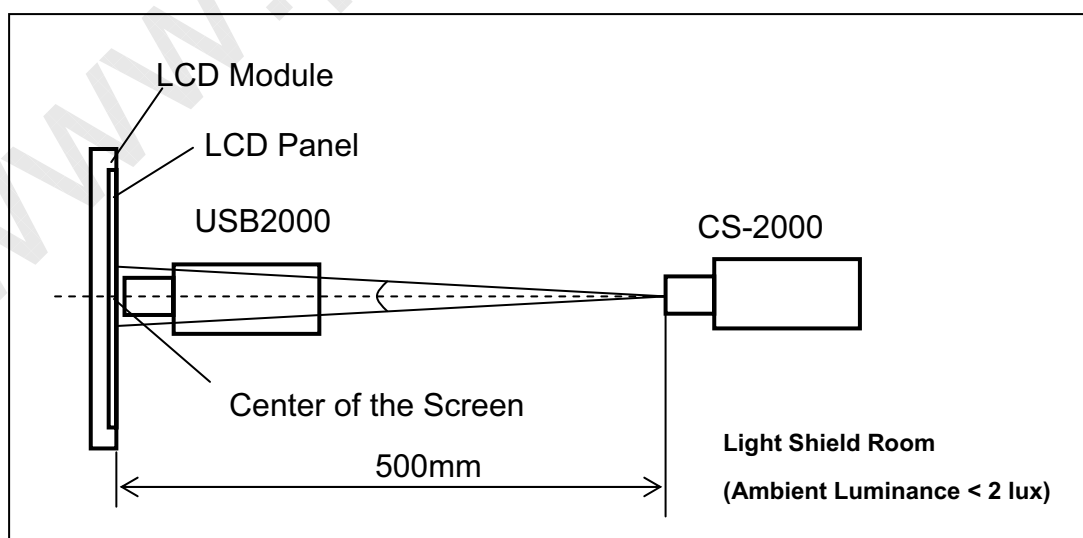

## Note (7) Measurement Setup:

The LCD Panel should be stabilized at given temperature for 20 minutes to avoid abrupt temperature change during measuring. In order to stabilize the luminance, the measurement should be executed after light source "C" for 20 minutes in a windless room.

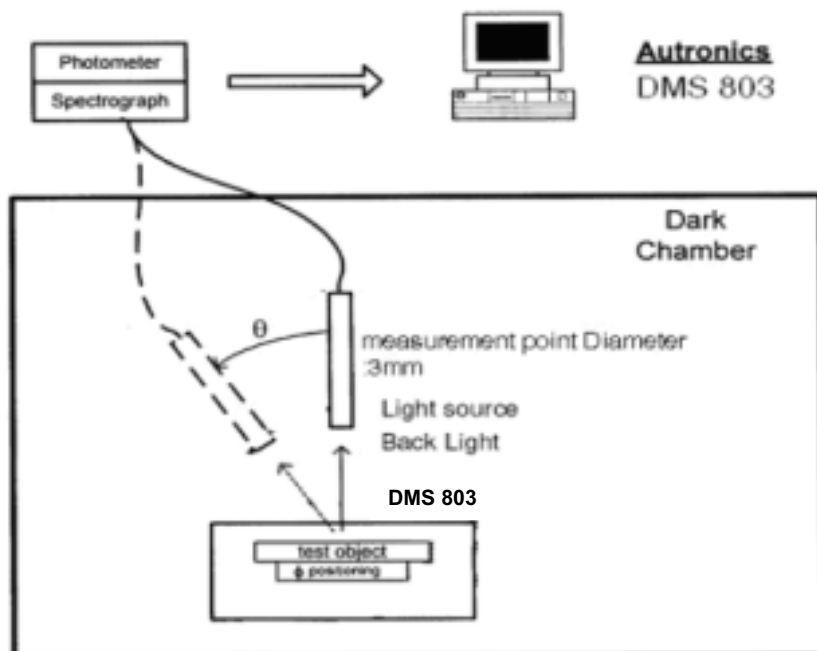
Note (8) Definition of Transmittance Variation ( $\delta T\%$ ):

Measure the transmittance at 9 points

$$\delta T\% = \frac{\text{Maximum } [T\%(1), T\%(2), \dots T\%(9)]}{\text{Minimum } [T\%(1), T\%(2), \dots T\%(9)]}$$

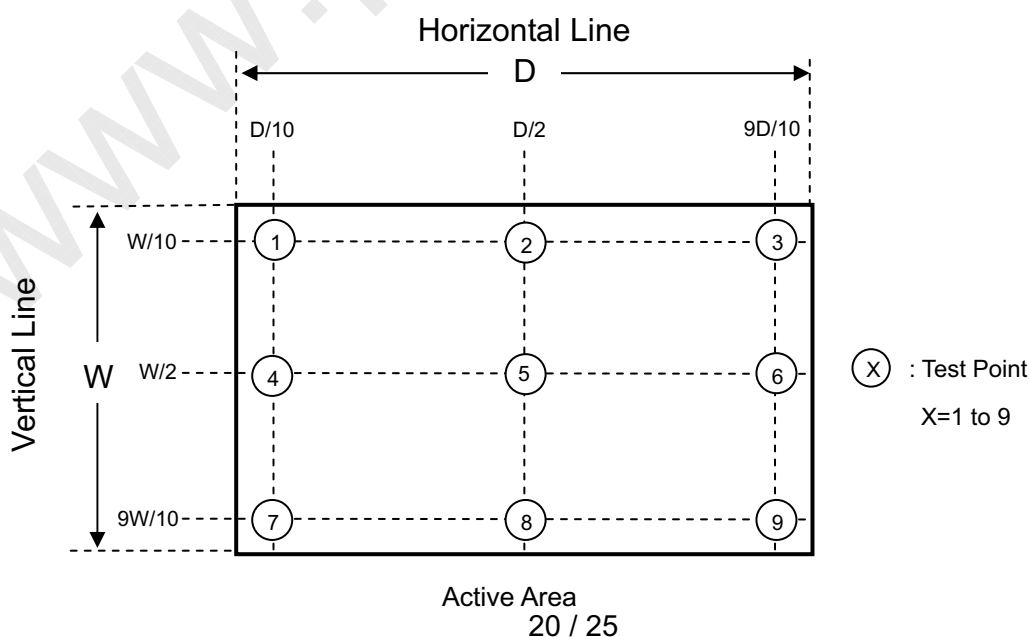

## 8. PACKAGING

### 8.1 PACKING SPECIFICATIONS

- (1) 27 open cells / 1 Box
- (2) Box dimensions: 570 (L) X 450 (W) X 320 (H) mm
- (3) Weight: approximately 19.1Kg (27 open cells per box)

### 8.2 PACKING METHOD

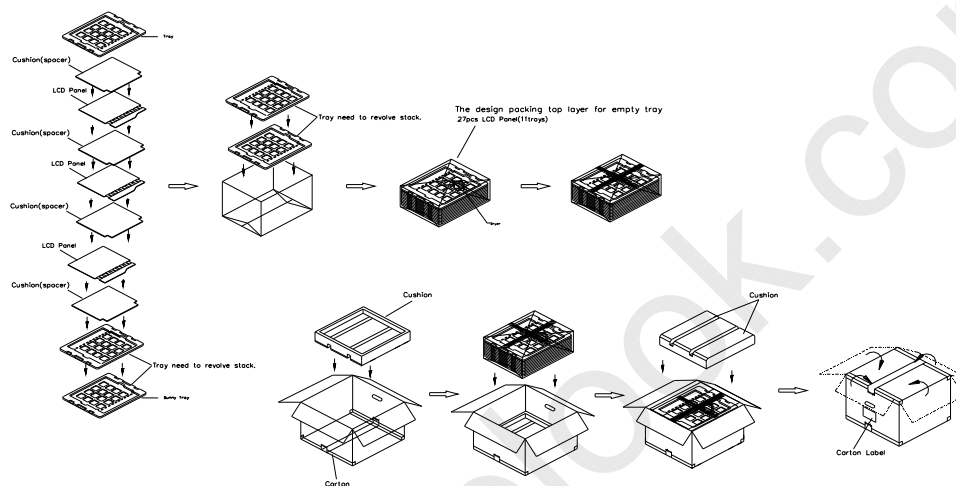

- (1) 27 LCD Cells+PCB/1 box
- (2) Carton dimensions : 570(L)x450(W)x320(H)mm
- (3) Weight : approximately 19.1kg(27 Cells per Carton).

#### Sea and Land Transportation

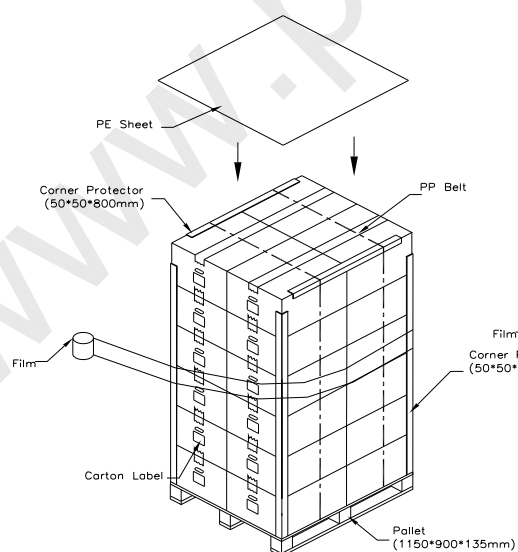

#### Air Transportation

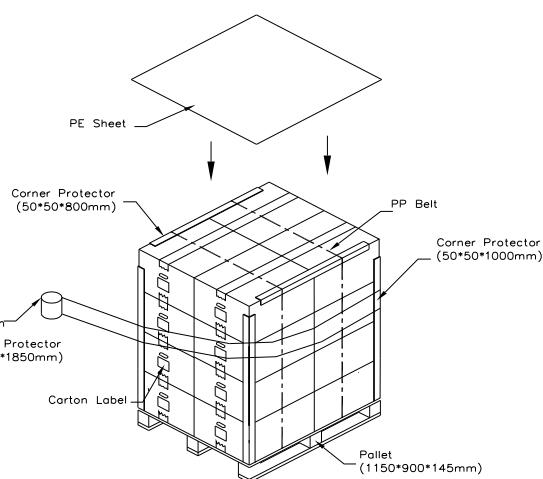

## 9. DEFINITION OF LABELS

### 9.1 CMO OPEN CELL LABEL

The barcode nameplate is pasted on each OPEN CELL as illustration for CMO internal control.



Barcode definition:

Serial ID: CM-I5301-X-X-X-XX-L-XX-L-YMD-NNNN

Code	Meaning	Description
CM	Supplier code	CMO=CM
I5301	Model number	M185B3-P01=I5301
X	Revision code	C1:1, C2:2, ...
X	Source driver IC code	Century=1, CLL=2, Demos=3, Epson=4, Fujitsu=5, Himax=6, Hitachi=7, Hynix=8, LDI=9, Matsushita=A, NEC=B, Novatek=C, OKI=D, Philips=E, Renesas=F, Samsung=G, Sanyo=H, Sharp=I, TI=J, Topro=K, Toshiba=L, Windbond=M
X	Gate driver IC code	
XX	Cell location	Tainan, Taiwan=TN
L	Cell line #	1,2,~,9,A,B,~,Y,Z
XX	Module location	Tainan, Taiwan=TN ; Ningbo China=NP
L	Module line #	1,2,~,9,A,B,~,Y,Z
YMD	Year, month, day	Year: 2001=1, 2002=2, 2003=3, 2004=4... Month: 1~12=1, 2, 3, ~, 9, A, B, C Day: 1~31= 1, 2, 3, ~, 9, A, B, C, ~, T, U, V
NNNN	Serial number	Manufacturing sequence of product

### 9.2 CARTON LABEL

The barcode nameplate is pasted on each box as illustration, and its definitions are as following explanation.



- (a) Model Name: M185B3 -P01
- (b) Carton ID: CMO internal control
- (c) Quantities: 27 pcs

## 10. RELIABILITY TEST

Environment test conditions are listed as following table.

Items	Required Condition	Note
Temperature Humidity Bias (THB)	Ta= 50°C , 80%RH, 240hours	(1)
High Temperature Operation (HTO)	Ta= 50°C , 50%RH , 240hours	
Low Temperature Operation (LTO)	Ta= 0°C , 240hours	
High Temperature Storage (HTS)	Ta= 60°C , 240hours	
Low Temperature Storage (LTS)	Ta= -20°C , 240hours	
Package Vibration Test	ISTA STANDARD 1.14Grms Random, Frequency Range: 1 ~ 200 Hz Top & Bottom: 30 minutes (+Z), 10 min (-Z), Right & Left: 10 minutes (X) Back & Forth 10 minutes (Y)	(2)
Thermal Shock Test (TST)	-20°C/30min, 60°C / 30min, 100 cycles	(1)
On/Off Test	25°C , On/10sec, Off /10sec, 30000 cycles	
Altitude Test	Operation: 10000 ft / 24hours Non-Operation: 30000 ft / 24hours	

Note (1) The tests are done with LCD modules (M185B3-LA1).

Note (2) The test is done with a package shown in Section 8.

## 11. PRECAUTIONS

### 11.1 ASSEMBLY AND HANDLING PRECAUTIONS

- (1) Do not apply rough force such as bending or twisting to the product during assembly.
- (2) To assemble backlight or install module into user's system can be only in clean working areas. The dust and oil may cause electrical short or worsen the polarizer.
- (3) It is not permitted to have pressure or impulse on the module because the LCD panel will be damaged.
- (4) Always follow the correct power sequence when the product is connecting and operating. This can prevent damage to the CMOS LSI chips during latch-up.
- (5) Do not pull the I/F connector in or out while the module is operating.
- (6) Use a soft dry cloth without chemicals for cleaning, because the surface of polarizer is very soft and easily scratched.
- (7) It is dangerous that moisture come into or contacted the product, because moisture may damage the product when it is operating.
- (8) High temperature or humidity may reduce the performance of module. Please store this product within the specified storage conditions.
- (9) When ambient temperature is lower than 10°C may reduce the display quality. For example, the response time will become slowly.

### 11.2 SAFETY PRECAUTIONS

- (1) If the liquid crystal material leaks from the panel, it should be kept away from the eyes or mouth. In case of contact with hands, skin or clothes, it has to be washed away thoroughly with soap.
- (2) After the product's end of life, it is not harmful in case of normal operation and storage.

### 11.3 OTHER

- (1) When fixed patterns are displayed for a long time, remnant image is likely to occur.

## 12. MECHANICAL DRAWING



