

## TFT LCD Approval Specification

**MODEL NO.:M190A1-C03**  
**FUNAI MODEL No.:TLCD100CME19**

Customer : _____
Approved by : _____
Note :

記錄	工作	審核	角色	投票
2007-09-03 12:08:07 CST	PMMD Director	cs_lee(李志聖 /56510/44926)	Director	Accept

## - CONTENTS -

. REVISION HISTORY	-----	3
1. GENERAL DESCRIPTION	-----	4
1.1 OVERVIEW		
1.2 FEATURES		
1.3 APPLICATION		
1.4 GENERAL SPECIFICATIONS		
2. ABSOLUTE MAXIMUM RATINGS	-----	4
3. SUGGESTIVE DRIVING CONDITION	-----	5
4. PANEL PIN DEFINITION	-----	6
5. OPTICAL CHARACTERISTICS	-----	8
5.1 TEST CONDITIONS		
5.2 OPTICAL SPECIFICATIONS		
6. PACKAGING	-----	12
6.1 PACKING SPECIFICATIONS		
6.2 PACKING METHOD		
7. DEFINITION OF LABELS	-----	14
8. PRECAUTIONS	-----	15
8.1 ASSEMBLY AND HANDLING PRECAUTIONS		
8.2 SAFETY PRECAUTIONS		
9. PANEL DRAWING	-----	16

REVISION HISTORY

Version	Date	Section	Description
Ver 2.0	Aug,28 '07	-	M190A1-C03 Specifications was first issued . The spec is same as M190A1-C01 . M190A1-C03 is for Funai Normal grade .

## 1. GENERAL DESCRIPTION

### 1.1 OVERVIEW

The M190A1-C03 is a 19-inch wide LCD cell with thin film transistors as active elements and contains 1440x900 pixels. Each pixel is divided into red, green and blue dot, which are arranged in vertical stripe. The cell is normally white mode, and can be applied to the transmission type display. Backlight unit (BLU) and circuit board for the cell are not built in.

### 1.2 FEATURES

- Wide viewing angle
- High contrast ratio
- Fast response time
- WXGA+ (1440 x 900 pixels) resolution

### 1.3 APPLICATION

- LCD Monitor
- LCD TV

### 1.4 GENERAL SPECIFICATIONS

Item	Specification	Unit
Max Panel Dimension (TFT)	419.84 X 266.05	mm
Glass thickness( TFT/ CF )	0.7/0.7	mm
Active Area	410.4 (H) x 256.5 (V) (19.05" diagonal)	mm
Driver Element	a-si TFT active matrix	-
Pixel Number	1440X R.G.B X 900	pixel
Pixel Pitch	0.285 (H) X 0.285 (V)	mm
Pixel Arrangement	RGB vertical stripe	-
Transmissive Mode	Normally white	-
Surface Treatment	Hard coating (3H), AG (Haze 25%)	-
Polarizer Type	E -Wide View	-
Polarizer Dimension	TFT	414.0 X 259.7
	CF	415.84 X 262.15
Polarizer Thickness	TFT	0.21
	CF	0.21
Weight	446(typ.)	g

## 2. ABSOLUTE MAXIMUM RATINGS

1. Storage condition : With shipping package.
2. Storage temperature range : 25±5 °C.
3. Storage humidity range : 50±10% RH.
4. Shelf life : 30 days

### 3. Suggestive Driving Condition

Item		Min.	Typ.	Max.	Unit		
Driving Voltage	$V_G$	On	23.7	24.5	25.3	V	
		Off	-6.6	-6.8	-7.0	V	
	$V_D$	B	Gam1	-	11.722	-	V
			Gam14	-	0.187	-	V
		W	Gam7	-	6.397	-	V
			Gam8	-	5.993	-	V
	$V_{COM}$	Center	-	5.16	-	V	
	G ↓ -D offset	2	-	-	us		
	Charging time	-	12.43	-	us		

B: Black pattern

W: White pattern

Gamma Voltage : Gam1 > Gam2 > Gam3 > ... > Gam10 G ↓ : gate pulse falling edge

### DRIVING TIMING DIAGRAM

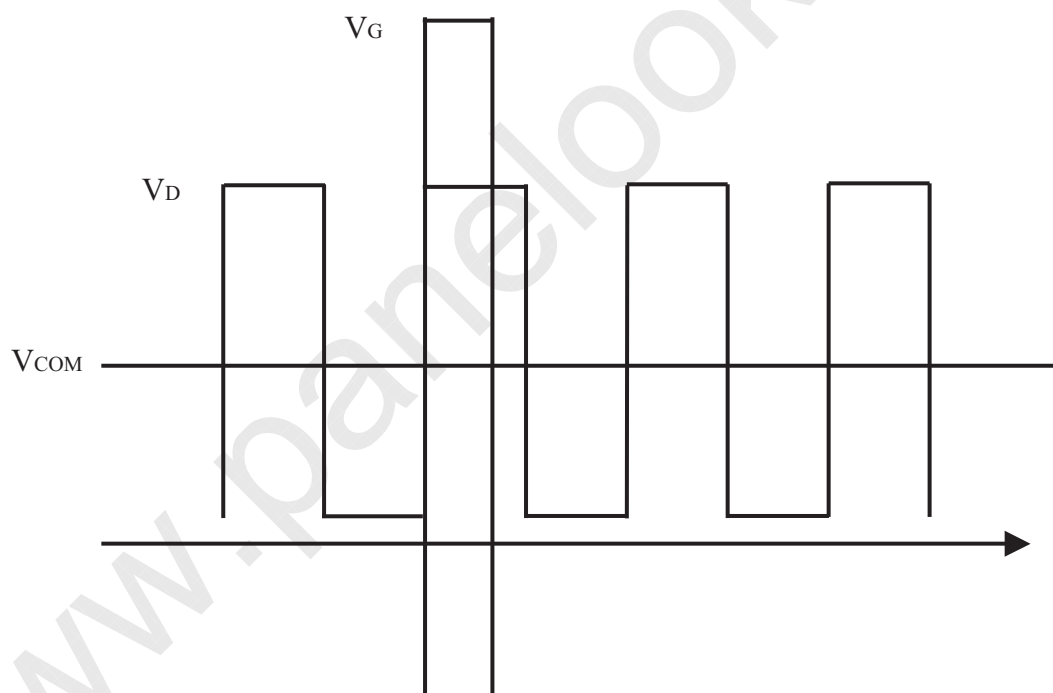

#### 4. PANEL PIN DEFINITION

##### 4.1 DATA PIN DEFINE

pin number	TAB1	TAB2~9	TAB10
1	Test	Test	Test
2	Test	Test	Test
3	Test	dummy	dummy
4	XAO	dummy	dummy
5	OE	dummy	dummy
6	CPV	dummy	dummy
7	STV2	dummy	dummy
8	VSS	dummy	dummy
9	VSS	dummy	dummy
10	VDD	dummy	dummy
11	VDD	dummy	dummy
12	Vee	dummy	dummy
13	Vgl	dummy	dummy
14	Vgl	dummy	dummy
15	Vgl	dummy	dummy
16	Vgl	dummy	dummy
17	dummy	dummy	dummy
18	Vgh	dummy	dummy
19	Vgh	dummy	dummy
20	Vgh	dummy	dummy
21	Vgh	dummy	dummy
22	dummy	dummy	dummy
23	Vst	dummy	dummy
24	Vcom	Vcom	Vcom
25	Test	Test	Test
26~457	OUT1~432	OUT1~432	OUT1~432
458	Test	Test	Test
459	dummy	dummy	Test
460	Vcom	Vcom	Vcom
461	dummy	dummy	Vst
462	dummy	dummy	Vgl
463	dummy	dummy	Vcom
464	dummy	dummy	Vcom
465	dummy	dummy	Test
466	Vcom	Vcom	Vcom
467	Vcom	Vcom	Vcom
468	Test	Test	Test
469	Test	Test	Test

Note: Test pin is recommend for floating



**Approval**

4.2 SCAN PIN DEFINE

Scan 1~3

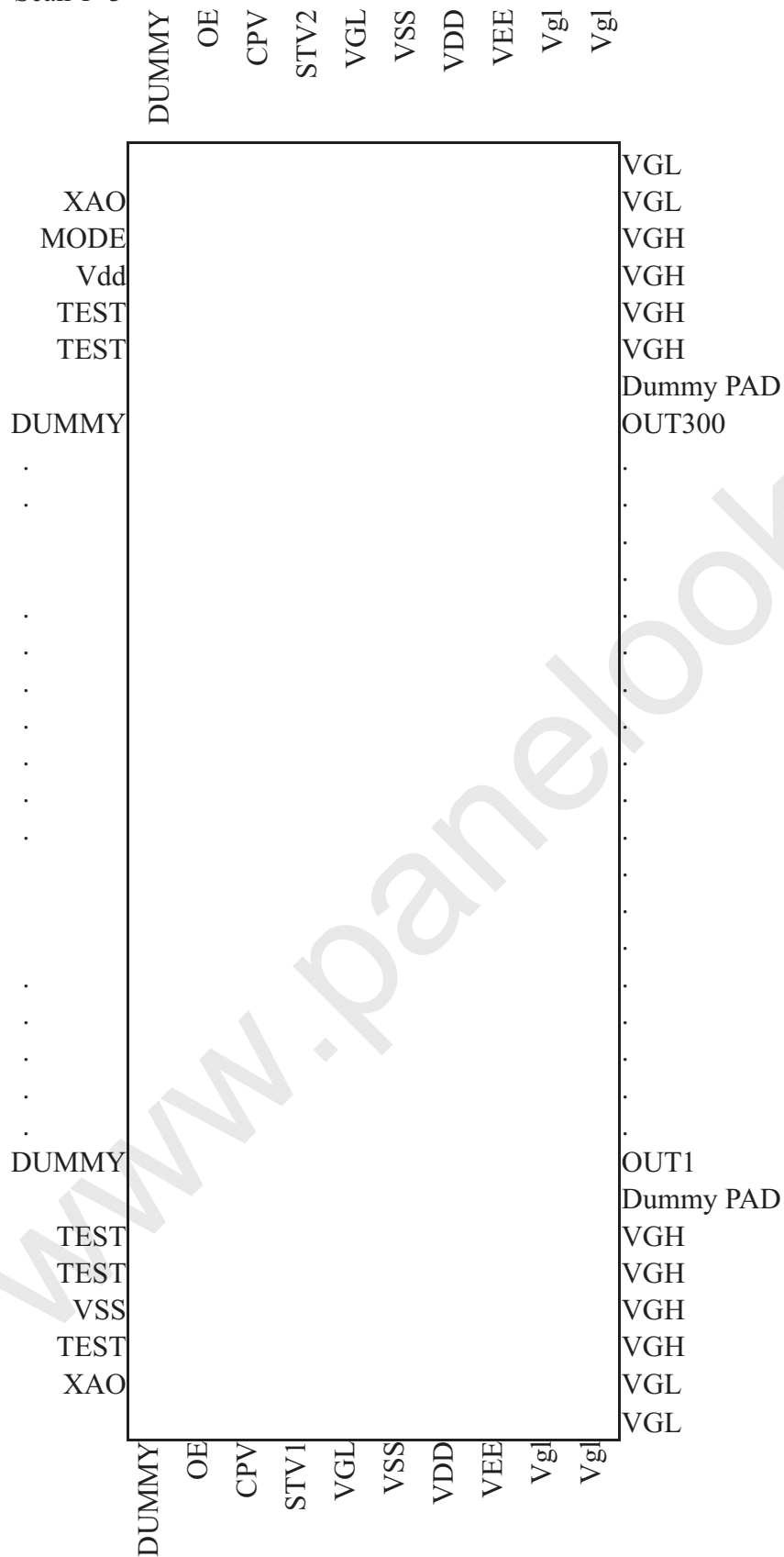

## 5. OPTICAL CHARACTERISTICS

### 5.1 TEST CONDITIONS

Item	Symbol	Value	Unit
Ambient Temperature	Ta	25±2	°C
Ambient Humidity	Ha	50±10	%RH
Gamma voltage	-	Refer to Item 3 driving condition	V
Vcom	-	most suitable Vcom	V

### 5.2 OPTICAL SPECIFICATION

ITEM		Symbol	Condition	MIN.	TYP.	MAX.	UNIT	NOTE
Contrast Ratio		CR	$\theta_x=\theta_y=0^\circ$ CS-1000T	600	850	-	%	4,1
Response Time (Black/White)		Tr	$\theta_x=\theta_y=0^\circ$	---	1.5	6.5	ms	5,1
		Tf	$\theta_x=\theta_y=0^\circ$	---	3.5	8.5	ms	
Center point Transmittance		T%	$\theta_x=\theta_y=0^\circ$ CS-1000T	5.4	6.0	-	%	7,1
Transmittance uniformity (13pts)		$\delta$ T%	$\theta_x=\theta_y=0^\circ$	-	1.25	1.4	-	6,1
Viewing Angle	Horizontal $\theta_x$ ( $\theta_y=0^\circ$ )	Right	CR ≥ 10 BM-5A	75	85	-	Deg	2,3,1
		Left		75	85	-	Deg	
	Vertical $\theta_y$ ( $\theta_x=0^\circ$ )	Up		70	80	-	Deg	
		Down		70	80	-	Deg	
Color Coordinate at center point	Red	Rcx	$\theta_x=\theta_y=0^\circ$	Typ -0.03	0.649	Typ +0.03	-	2,0
		Rcy	$\theta_x=\theta_y=0^\circ$		0.332		-	
	Green	Gcx	$\theta_x=\theta_y=0^\circ$		0.274		-	
		Gcy	$\theta_x=\theta_y=0^\circ$		0.589		-	
	Blue	Bcx	$\theta_x=\theta_y=0^\circ$		0.148		-	
		Bcy	$\theta_x=\theta_y=0^\circ$		0.101		-	
	White	Wcx	$\theta_x=\theta_y=0^\circ$		0.320		-	
		Wcy	$\theta_x=\theta_y=0^\circ$		0.356		-	

#### Note (0)

Light source is the standard light source "C" which is defined by CIE and driving voltages are based on suitable gamma voltages. The calculating method is as following :

- 1.Measure Module's and BLU's spectrums. White is without signal input and R, G, B are with signal input. BLU is supplied by CMO.
- 2.Calculate cell's spectrum.
- 3.Calculate cell's chromaticity by using the spectrum of standard light source "C"



## Note (1)

Light source is the BLU which is supplied by CMO and driving voltages are based on suitable gamma voltages. White is without signal input and R, G, B are with signal input. SPEC is judged by CMO's golden sample .

## Note (2) : Measurement setup:

The LCD module should be stabilized at given temperature for 20 minutes to avoid abrupt temperature change during measuring. In order to stabilize the luminance, the measurement should be executed after lighting backlight for 20 minutes in a windless room.

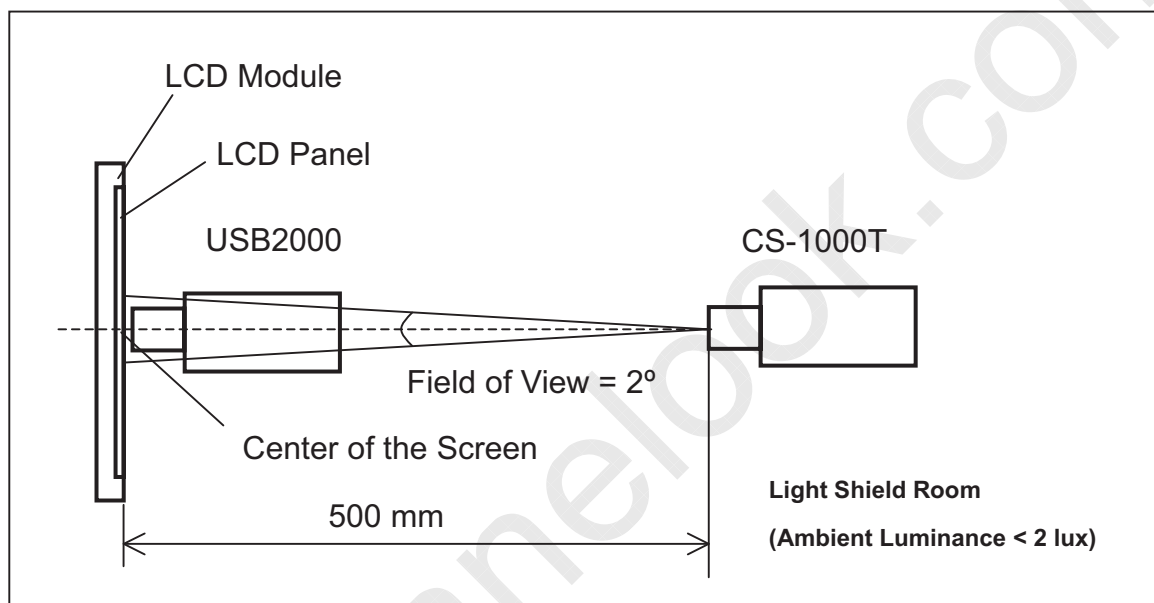

Note (3) : Definition of viewing angle ( $\theta_x, \theta_y$ ):

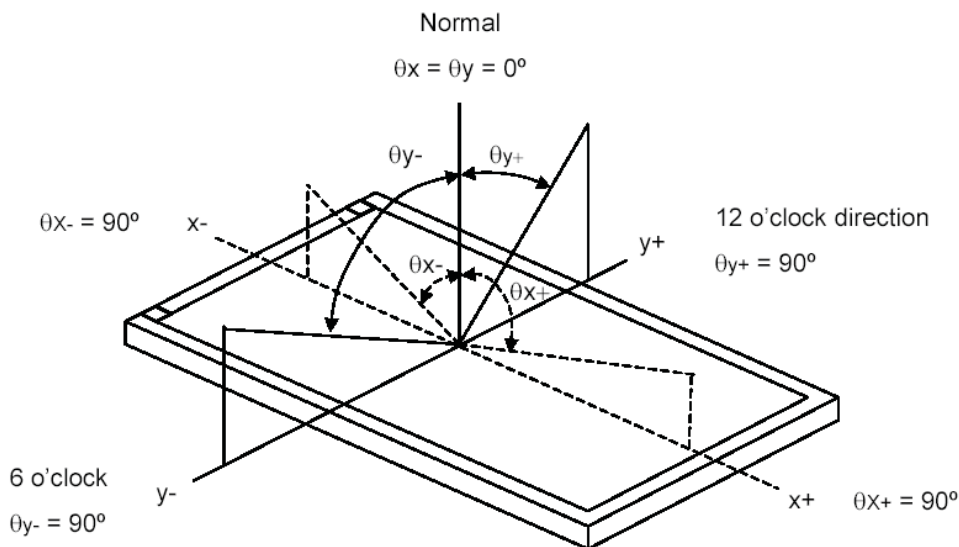

Note (4) : Definition of Contrast Ratio (CR):

Ratio of gray max ( $G_{max}$ ), gray min ( $G_{min}$ ), at the center point of panel.

$$CR = \frac{\text{Luminance with all pixel white } (G_{max})}{\text{Luminance with all pixel Black } (G_{min})}$$

Note (5) : Definition of Response Time ( $T_R, T_F$ ):

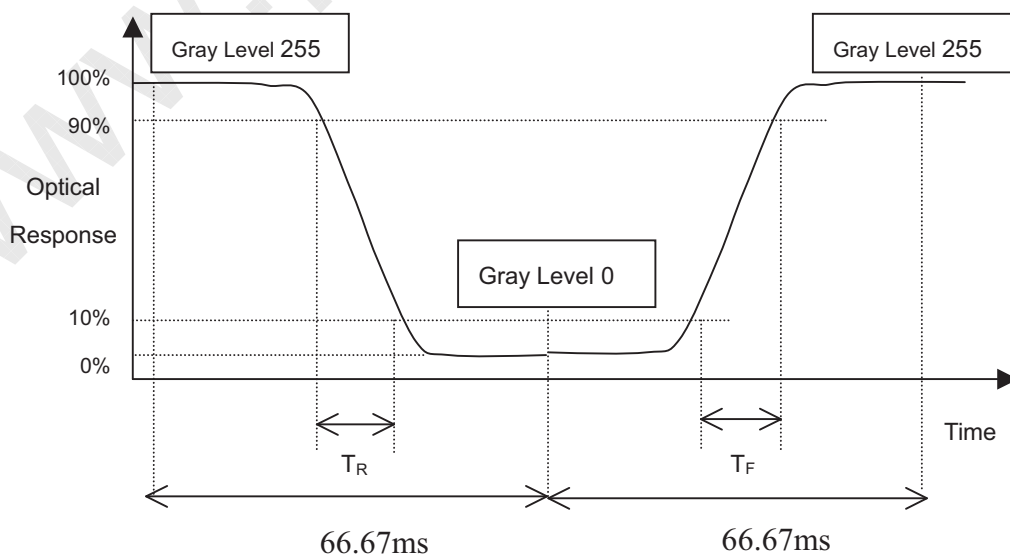

Note (6) : Definition of Transmittance Variation ( $\delta T\%$ ):

Measure the transmittance at 13 points

$$\delta T\% = \frac{\text{Maximum } [T\%(1), T\%(2), \dots T\%(13)]}{\text{Minimum } [T\%(1), T\%(2), \dots T\%(13)]}$$

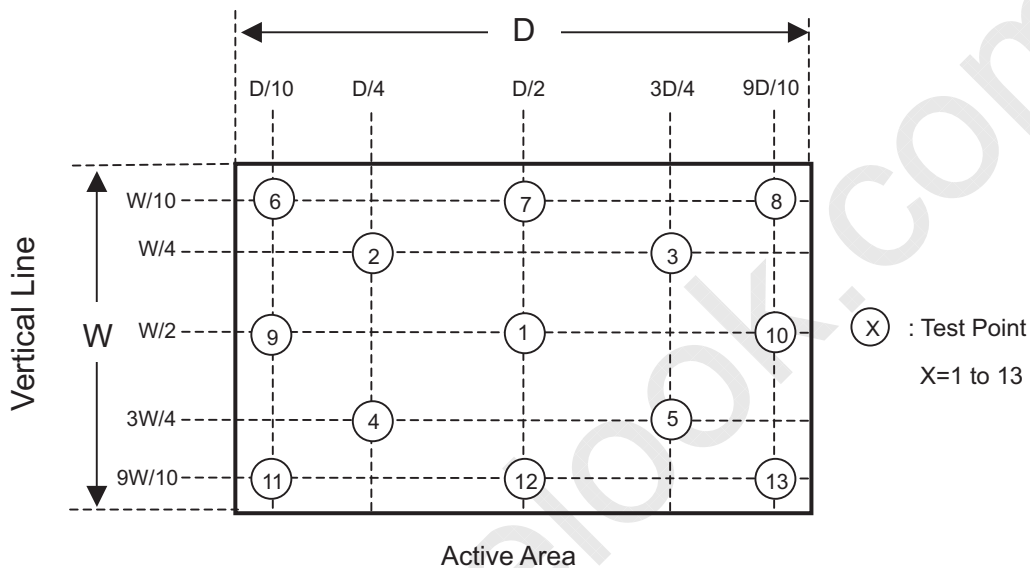

Note (7) : Definition of Transmittance( $T\%$ ):

Module is without signal input.

BLU is Supplied by CMO .

$$\text{Transmittance} = \frac{\text{Luminance of LCD module}}{\text{Luminance of backlight}} * 100\%$$

## 6. PACKAGING

### 6.1.PACKING SPECIFICATION

1. 20 pcs LCD panel / 1 Box
2. Box Dimension :472 (L) X376 (W) X 617(H) mm
3. Weight : Approximately 26.9Kg (40 cells per Carton)

### 6.2 PACKING METHOD

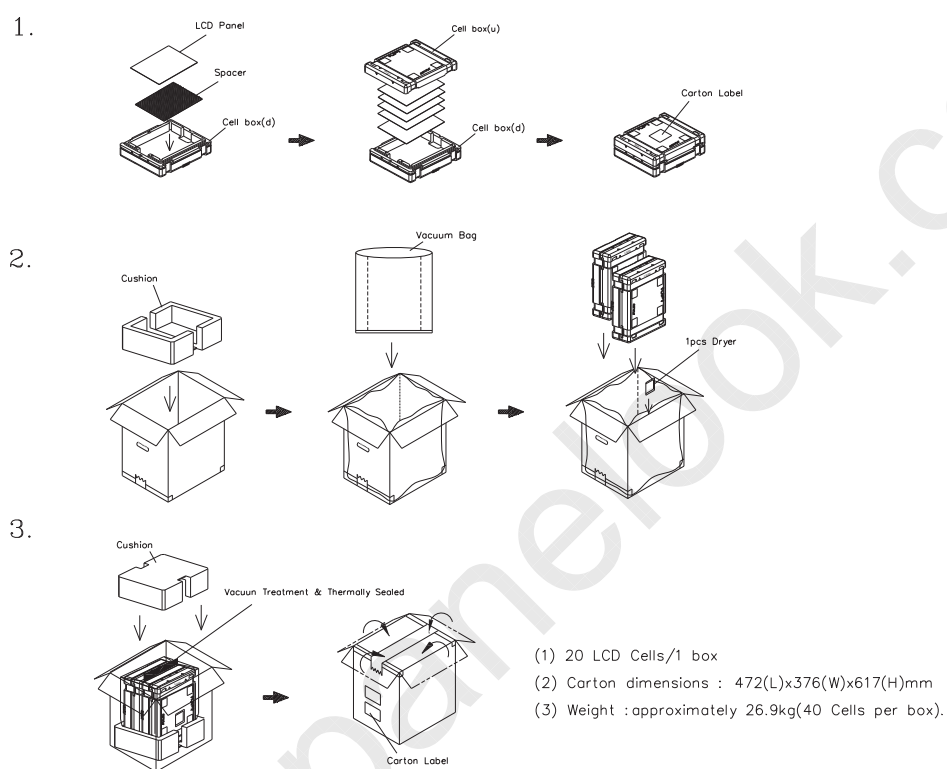

Figure. 6-1 Packing method

1

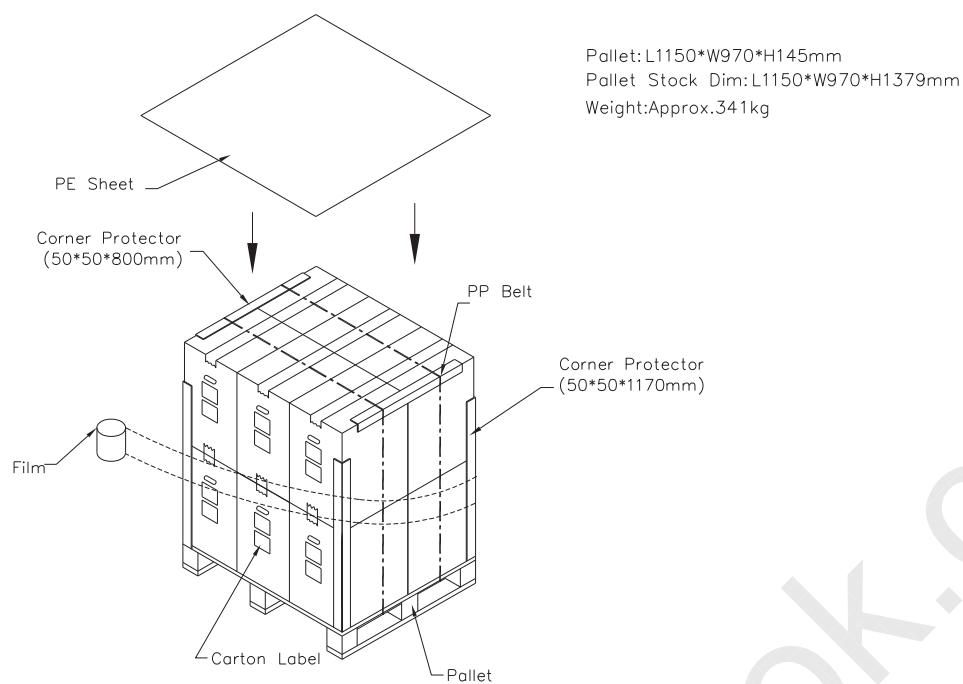

Figure. 6-2 Packing method

## 7. DEFINITION OF LABEL

1. Model Name: M190A1- C03
2. Panel Type: version control
3. Quantity: 19pcs / PP box
4. Case ID: serial number.
5. Note: Notification, if necessary.
6. Barcode: Case ID in code39 format

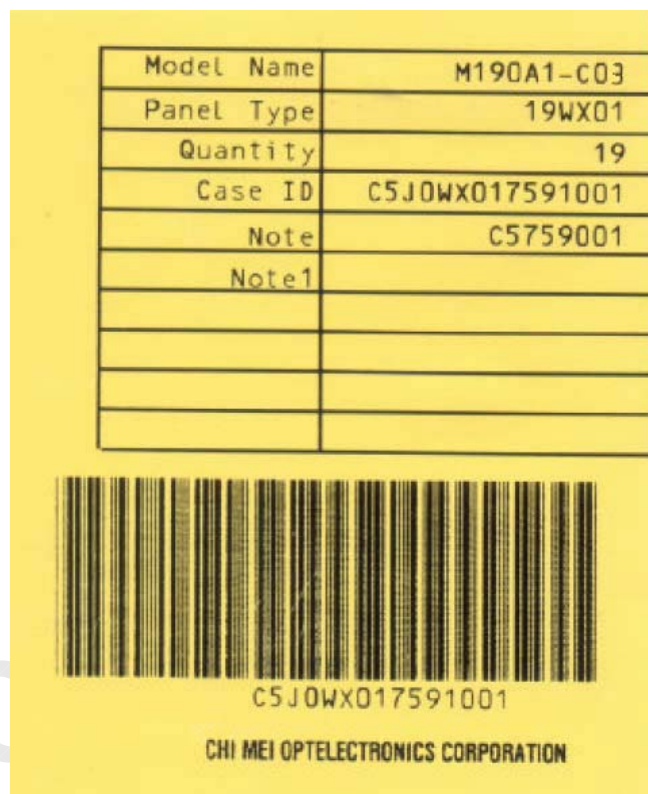

Figure. 7-1 Carton Label

## 8. PRECAUTIONS

### 8.1 ASSEMBLY AND HANDLING PRECAUTIONS

1. Do not apply rough force such as bending or twisting to the cell during assembly.
2. To assemble or install cell into customer's module can be only in clean working areas. The dust and oil may cause electrical short or worsen the polarizer.
3. It's not permitted to have pressure or impulse on the module because the LCD panel and Backlight will be damaged.
4. Use a soft dry cloth without chemicals for cleaning, because the surface of polarizer is very soft and easily scratched.
5. It is dangerous that moisture come into or contacted the LCD panel, because moisture may damage TFT circuit .
6. High temperature or humidity may reduce the performance of cell. Please store LCD cell within the specified storage conditions.

### 8.2 SAFETY PRECAUTIONS

1. If the liquid crystal material leaks from the panel, it should be kept away from the eyes or mouth. In case of contact with hands, skin or clothes, it has to be washed away thoroughly with soap.