

## TFT LCD Approval Specification

# MODEL NO.: M190A1-LOC

Customer: \_\_\_\_\_

Approved by: \_\_\_\_\_

Note:

記錄	工作	審核	角色	投票
2008-10-14 10:44:48 CST	PMMD II Director	kevin_wu(吳柏勳 /56520/54894)	Director	Accept

## - CONTENTS -

### REVISION HISTORY

#### 1. GENERAL DESCRIPTION

- 1.1 OVERVIEW
- 1.2 FEATURES
- 1.3 APPLICATION
- 1.4 GENERAL SPECIFICATIONS
- 1.5 MECHANICAL SPECIFICATIONS

#### 2. ABSOLUTE MAXIMUM RATINGS

- 2.1 ABSOLUTE RATINGS OF ENVIRONMENT
- 2.2 ELECTRICAL ABSOLUTE RATINGS
  - 2.2.1 TFT LCD MODULE
  - 2.2.2 BACKLIGHT UNIT

#### 3. ELECTRICAL CHARACTERISTICS

- 3.1 TFT LCD MODULE
- 3.2 V<sub>CC</sub> POWER DIP CONDITION
- 3.3 BACKLIGHT UNIT

#### 4. BLOCK DIAGRAM

- 4.1 TFT LCD MODULE
- 4.2 BACKLIGHT UNIT

#### 5. INPUT TERMINAL PIN ASSIGNMENT

- 5.1 TFT LCD MODULE
- 5.2 LVDS DATA MAPPING TABLE
- 5.3 BACKLIGHT UNIT
- 5.4 COLOR DATA INPUT ASSIGNMENT

#### 6. INTERFACE TIMING

- 6.1 INPUT SIGNAL TIMING SPECIFICATIONS
- 6.2 POWER ON/OFF SEQUENCE

#### 7. OPTICAL CHARACTERISTICS

- 7.1 TEST CONDITIONS
- 7.2 OPTICAL SPECIFICATIONS

#### 8. PACKAGING

- 8.1 PACKING SPECIFICATIONS
- 8.2 PACKING METHOD

#### 9. DEFINITION OF LABELS

#### 10. PRECAUTIONS

- 10.1 ASSEMBLY AND HANDLING PRECAUTIONS
- 10.2 SAFETY PRECAUTIONS

#### 11. MECHANICAL CHARACTERISTICS

**REVISION HISTORY**

	Date	Section	Description
3.0	Jun. 09, 08'	All	M190A1-LOC Specifications was first issued.
3.1	Jul. 04, 08'	7.2	Bx value changes from 0.0152 to 0.152.

## 1. GENERAL DESCRIPTION

### 1.1 OVERVIEW

M190A1-LOC is a 19" wide TFT Liquid Crystal Display module with 4 CCFL Backlight unit and 30 pins 2ch-LVDS interface. This module supports 1440 x 900 WXGA+ mode and can display 16.7M colors. The inverter module for Backlight is not built in.

### 1.2 FEATURES

- Super Wide viewing angle.
- Super High contrast ratio
- Super fast response time
- High color saturation
- WXGA+ (1440 x 900 pixels) resolution
- DE (Data Enable) only mode
- LVDS (Low Voltage Differential Signaling) interface
- RoHS Compliance

### 1.3 APPLICATION

- TFT LCD Monitor

### 1.4 GENERAL SPECIFICATIONS

Item	Specification	Unit	Note
Diagonal Size	481.4 (18.95" diagonal)	mm	
Active Area	408.24 (H) x 255.15 (V)	mm	(1)
Bezel Opening Area	412.24 (H) x 259.15 (V)	mm	
Driver Element	a-si TFT active matrix	-	-
Pixel Number	1440 x R.G.B. x 900	pixel	-
Pixel Pitch	0.2835 (H) x 0.2835 (V)	mm	-
Pixel Arrangement	RGB vertical stripe	-	-
Display Colors	16.7M	color	-
Transmissive Mode	Normally White	-	-
Color Saturation	92%NTSC (typ.)		
Surface Treatment	Hard coating (3H), Anti-glare (Haze 25)	-	-

### 1.5 MECHANICAL SPECIFICATIONS

Item	Min.	Typ.	Max.	Unit	Note	
Module Size	Horizontal(H)	427.5	428	428.5	mm	(1)
	Vertical(V)	277.5	278	278.5	mm	
	Depth(D)	-	17.1	17.6	mm	
Weight	-	1835	1880	g	-	

Note (1) Please refer to the attached drawings for more information of front and back outline dimensions.

## 2. ABSOLUTE MAXIMUM RATINGS

### 2.1 ABSOLUTE RATINGS OF ENVIRONMENT

Item	Symbol	Value		Unit	Note
		Min.	Max.		
Storage Temperature	T <sub>ST</sub>	-20	+60	°C	(1)
Operating Ambient Temperature	T <sub>OP</sub>	0	+50	°C	(1), (2)
Shock (Non-Operating)	S <sub>NOP</sub>	-	50	G	(3), (5)
Vibration (Non-Operating)	V <sub>NOP</sub>	-	1.5	G	(4), (5)

Note (1) Temperature and relative humidity range is shown in the figure below.

(a) 90 %RH Max. ( $T_a \leq 40^\circ\text{C}$ ).

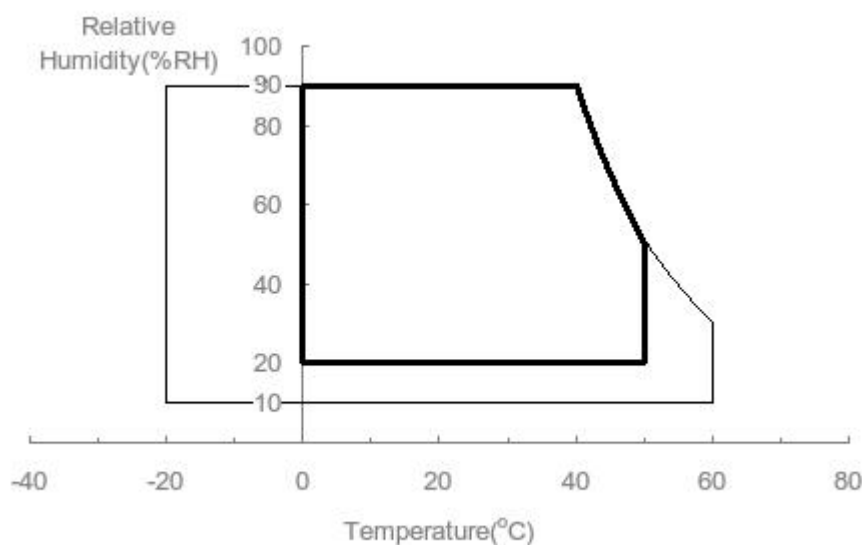

(b) Wet-bulb temperature should be 39 °C Max. ( $T_a > 40^\circ\text{C}$ ).

(c) No condensation.

Note (2) The temperature of panel display surface area should be 0 °C Min. and 60 °C Max.

Note (3) 50G/11ms, half sine wave, 1 time for  $\pm X$ ,  $\pm Y$ ,  $\pm Z$ .

Note (4) 10 ~ 300 Hz, 10min/cycle, 3 cycles each X, Y, Z.

Note (5) At testing Vibration and Shock, the fixture in holding the module has to be hard and rigid enough so that the module would not be twisted or bent by the fixture.

At Room Temperature

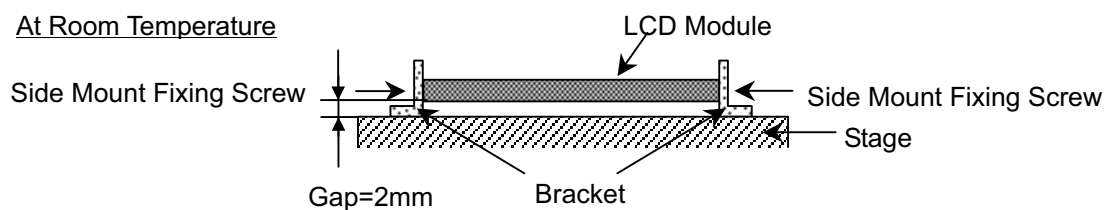

## 2.2 ELECTRICAL ABSOLUTE RATINGS

### 2.2.1 TFT LCD MODULE

Item	Symbol	Value		Unit	Note
		Min.	Max.		
Power Supply Voltage	Vcc	-0.3	+6.0	V	(1)

### 2.2.2 BACKLIGHT UNIT

Item	Symbol	Value		Unit	Note
		Min.	Max.		
Lamp Voltage	$V_L$	-	2.0K	$V_{RMS}$	(1), (2), $I_L = 7.0mA$
Lamp Current	$I_L$	-	10.0	$mA_{RMS}$	(1), (2)
Lamp Frequency	$F_L$	-	80	KHZ	

Note (1) Permanent damage to the device may occur if maximum values are exceeded. Function operation should be restricted to the conditions described under Normal Operating Conditions.

Note (2) Specified values are for lamp (Refer to 3.3 for further information).

### 3. ELECTRICAL CHARACTERISTICS

#### 3.1 TFT LCD MODULE

Ta = 25 ± 2 °C

Parameter	Symbol	Value			Unit	Note
		Min.	Typ.	Max.		
Power Supply Voltage	V <sub>CC</sub>	4.5	5.0	5.5	V	-
Ripple Voltage	V <sub>RP</sub>	-	-	100	mV	-
Rush Current	I <sub>RUSH</sub>	-	-	3	A	(2)
Power Supply Current	White	-	0.45	0.55	A	(3)a
	Black	-	0.67	0.80	A	(3)b
	Vertical Stripe	-	0.65	0.78	A	(3)c
LVDS differential input voltage	V <sub>id</sub>	100	-	600	mV	
LVDS common input voltage	V <sub>ic</sub>	-	1.2	-	V	

Note (1) The module should be always operated within above ranges.

Note (2) Measurement Conditions:

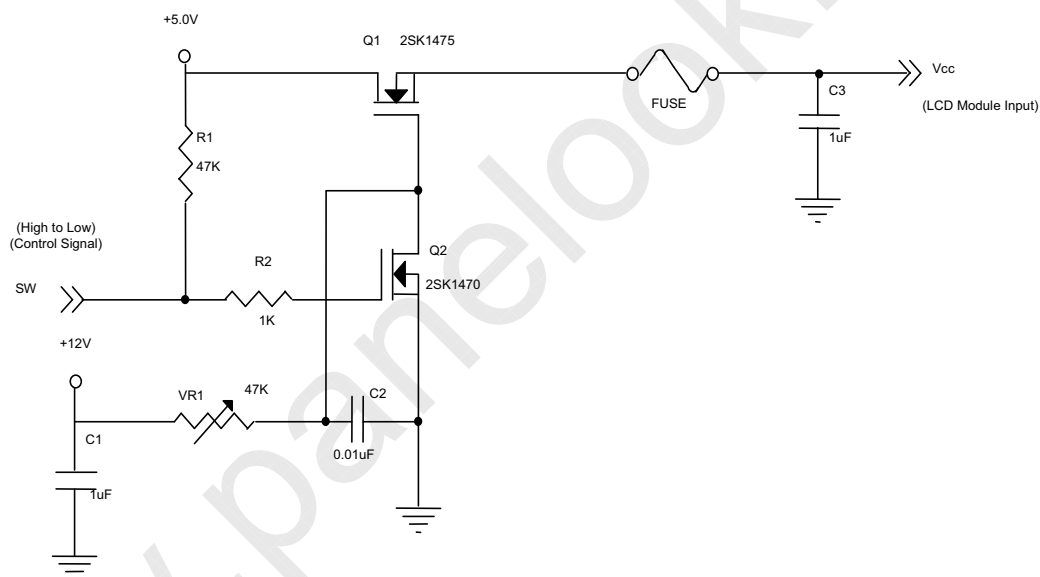

**Vcc rising time is 470μs**

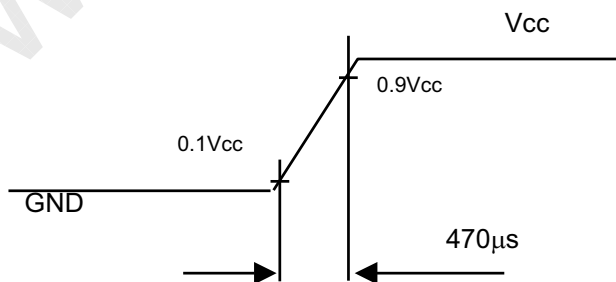

Note (3) The specified power supply current is under the conditions at  $V_{cc} = 5.0\text{ V}$ ,  $T_a = 25 \pm 2\text{ }^\circ\text{C}$ ,  $f_v = 60\text{ Hz}$ , whereas a power dissipation check pattern below is displayed.

a. White Pattern

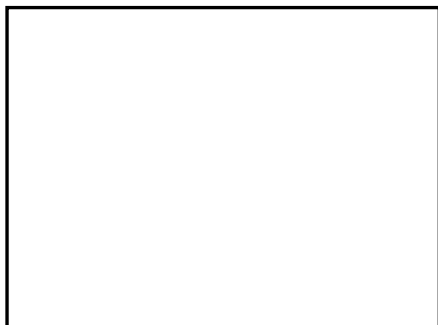

Active Area

b. Black Pattern



Active Area

c. Vertical Stripe Pattern

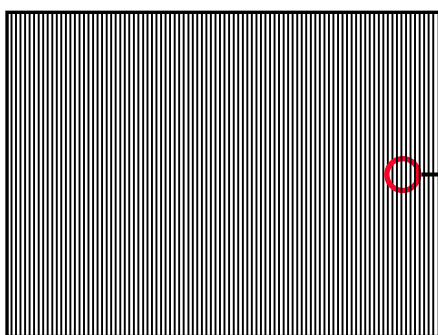

Active Area

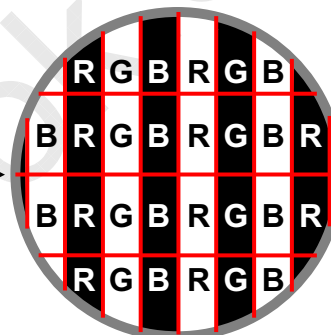

### 3.2 $V_{cc}$ POWER DIP CONDITION:

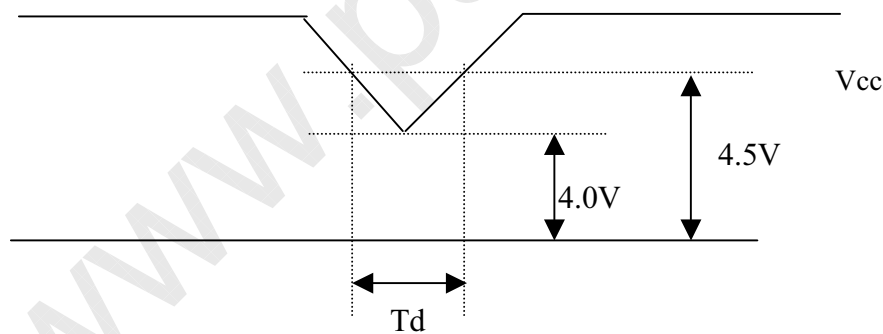

Dip condition:  $4.0\text{ V} \leq V_{cc} \leq 4.5\text{ V}$ ,  $T_d \leq 20\text{ ms}$



## 3.3 BACKLIGHT UNIT

Ta = 25 ± 2 °C

Parameter	Symbol	Value			Unit	Note
		Min.	Typ.	Max.		
Lamp Input Voltage	V <sub>L</sub>	---	750	825	V <sub>RMS</sub>	I <sub>L</sub> = 7.0 mA
Lamp Current	I <sub>L</sub>	3.0	7.0	8.0	mA <sub>RMS</sub>	(1)
Lamp Turn On Voltage	V <sub>S</sub>	---	---	1220(25°C)	V <sub>RMS</sub>	(2)
		---	---	1620(0°C)	V <sub>RMS</sub>	(2)
Operating Frequency	F <sub>L</sub>	40	---	80	KHz	(3)
Lamp Life Time	L <sub>BL</sub>	40000	---	---	Hrs	(5)
Power Consumption	P <sub>L</sub>	---	21.0	---	W	(4), I <sub>L</sub> = 7.0 mA

Note (1) Lamp current is measured by utilizing high frequency current meters as shown below:

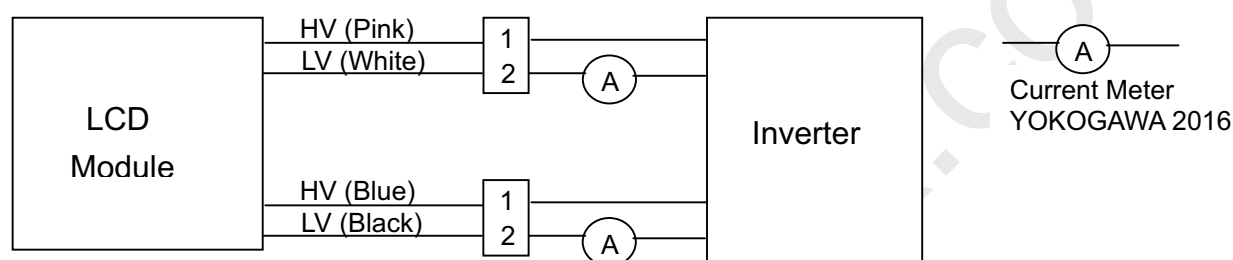

Note (2) The voltage shown above should be applied to the lamp for more than 1 second after startup. Otherwise the lamp may not be turned on.

Note (3) The lamp frequency may produce interference with horizontal synchronous frequency from the display, and this may cause line flow on the display. In order to avoid interference, the lamp frequency should be detached from the horizontal synchronous frequency and its harmonics as far as possible.

Note (4)  $P_L = I_L \times V_L \times 4 \text{ CCFLs}$

Note (5) The lifetime of lamp can be defined as the time in which it continues to operate under the condition Ta = 25 ± 2 °C and I<sub>L</sub> = 7.0 mA rms until one of the following events occurs:

- (a) When the brightness becomes or lower than 50% of its original value.
- (b) When the effective ignition length becomes ≤ 80% of its original value.

(The effective ignition length is a scope that luminance is over 70% of that at the center point.)

Note (6) The waveform of the voltage output of inverter must be area-symmetric and the design of the inverter must have specifications for the modularized lamp. The performance of the Backlight, such as lifetime or brightness, is greatly influenced by the characteristics of the DC-AC inverter for the lamp. All the parameters of an inverter should be carefully designed to avoid producing too much current leakage from high voltage output of the inverter. When designing or ordering the inverter please make sure that a poor lighting caused by the mismatch of the Backlight and the inverter (miss-lighting, flicker, etc.) never occurs. If the above situation is confirmed, the module should be operated in the same manners when it is installed in your instrument.

The output of the inverter must have symmetrical (negative and positive) voltage waveform and symmetrical current waveform. (Unsymmetrical ratio is less than 10%) Please do not use the inverter which has unsymmetrical voltage and unsymmetrical current and spike wave. Lamp frequency may produce interface with horizontal synchronous frequency and as a result this may cause beat on the display. Therefore lamp frequency shall be as away possible from the horizontal synchronous frequency and from its harmonics in order to prevent interference.

Requirements for a system inverter design, which is intended to have a better display performance, a better power efficiency and a more reliable lamp. It shall help increase the lamp lifetime and reduce its leakage current.

- The asymmetry rate of the inverter waveform should be 10% below;
- The distortion rate of the waveform should be within  $\sqrt{2} \pm 10\%$ ;
- The ideal sine wave form shall be symmetric in positive and negative polarities.

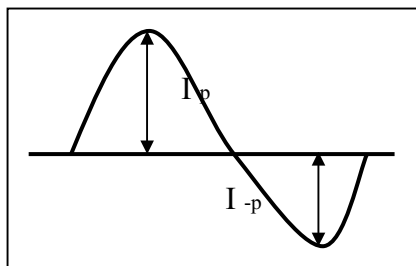

\* Asymmetry rate:

$$|I_p - I_{-p}| / I_{rms} * 100\%$$

\* Distortion rate

$$I_p \text{ (or } I_{-p}) / I_{rms}$$

## 4. BLOCK DIAGRAM

### 4.1 TFT LCD MODULE

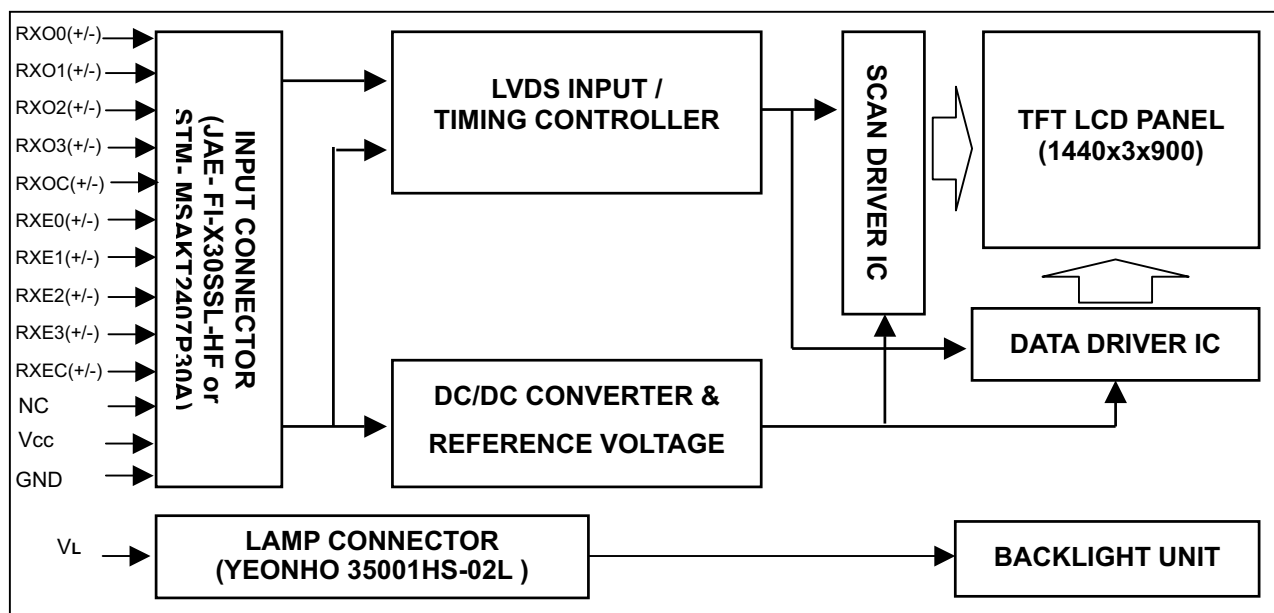

### 4.2 BACKLIGHT UNIT

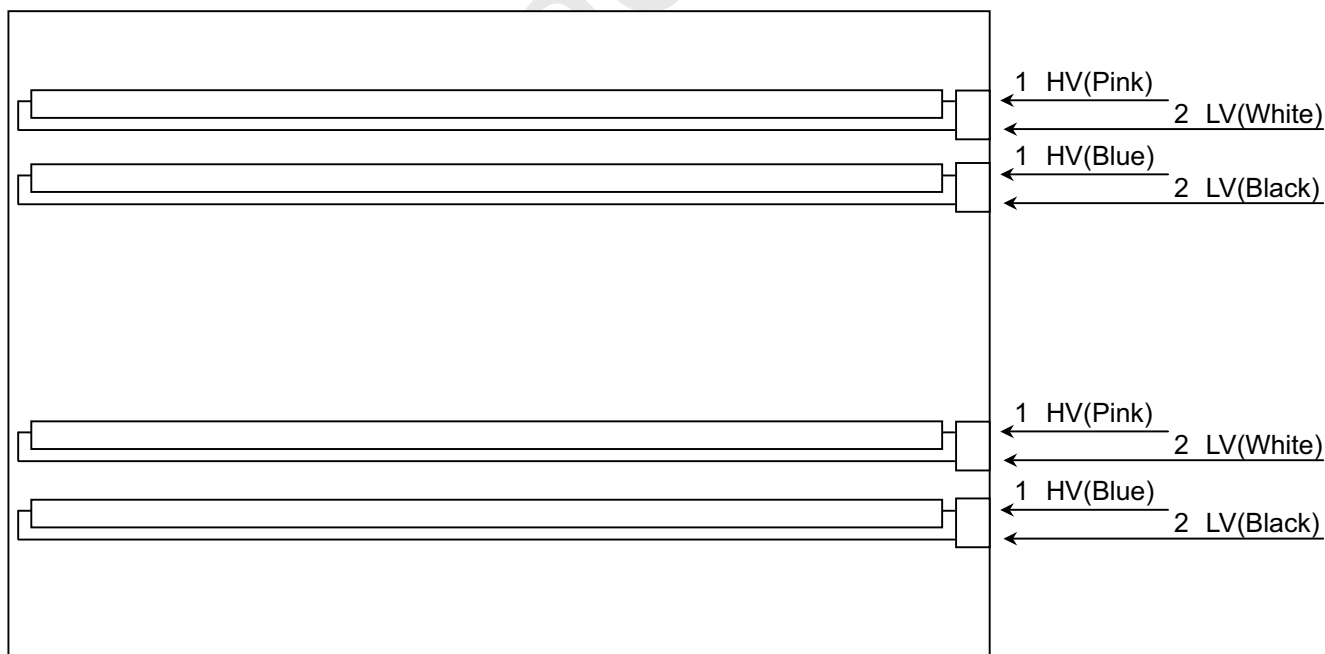

Note: On the same side, the same-polarity lamp voltage design for lamps is recommended.

## 5. INPUT TERMINAL PIN ASSIGNMENT

### 5.1 TFT LCD MODULE

Pin	Name	Description
1	RX00-	Negative LVDS differential data input. Channel O0 (odd)
2	RX00+	Positive LVDS differential data input. Channel O0 (odd)
3	RX01-	Negative LVDS differential data input. Channel O1 (odd)
4	RX01+	Positive LVDS differential data input. Channel O1 (odd)
5	RX02-	Negative LVDS differential data input. Channel O2 (odd)
6	RX02+	Positive LVDS differential data input. Channel O2 (odd)
7	GND	Ground
8	RXOC-	Negative LVDS differential clock input. (odd)
9	RXOC+	Positive LVDS differential clock input. (odd)
10	RX03-	Negative LVDS differential data input. Channel O3(odd)
11	RX03+	Positive LVDS differential data input. Channel O3 (odd)
12	RXE0-	Negative LVDS differential data input. Channel E0 (even)
13	RXE0+	Positive LVDS differential data input. Channel E0 (even)
14	GND	Ground
15	RXE1-	Negative LVDS differential data input. Channel E1 (even)
16	RXE1+	Positive LVDS differential data input. Channel E1 (even)
17	GND	Ground
18	RXE2-	Negative LVDS differential data input. Channel E2 (even)
19	RXE2+	Positive LVDS differential data input. Channel E2 (even)
20	RXEC-	Negative LVDS differential clock input. (even)
21	RXEC+	Positive LVDS differential clock input. (even)
22	RXE3-	Negative LVDS differential data input. Channel E3 (even)
23	RXE3+	Positive LVDS differential data input. Channel E3 (even)
24	GND	Ground
25	NC	Not connection, this pin should be open.
26	NC	Not connection, this pin should be open.
27	NC	Not connection, this pin should be open.
28	Vcc	+5.0V power supply
29	Vcc	+5.0V power supply
30	Vcc	+5.0V power supply

Note (1) Connector Part No.: JAE- FI-X30SSL-HF or STM MSAKT2407P30A.

Note (2) The first pixel is odd.

Note (3) Input signal of even and odd clock should be the same timing.

## 5.2 LVDS DATA MAPPING TABLE

LVDS Channel O0	LVDS output	D7	D6	D4	D3	D2	D1	D0
	Data order	OG0	OR5	OR4	OR3	OR2	OR1	OR0
LVDS Channel O1	LVDS output	D18	D15	D14	D13	D12	D9	D8
	Data order	OB1	OB0	OG5	OG4	OG3	OG2	OG1
LVDS Channel O2	LVDS output	D26	D25	D24	D22	D21	D20	D19
	Data order	DE	NA	NA	OB5	OB4	OB3	OB2
LVDS Channel O3	LVDS output	D23	D17	D16	D11	D10	D5	D27
	Data order	NA	OB7	OB6	OG7	OG6	OR7	OR6
LVDS Channel E0	LVDS output	D7	D6	D4	D3	D2	D1	D0
	Data order	EG0	ER5	ER4	ER3	ER2	ER1	ER0
LVDS Channel E1	LVDS output	D18	D15	D14	D13	D12	D9	D8
	Data order	EB1	EB0	EG5	EG4	EG3	EG2	EG1
LVDS Channel E2	LVDS output	D26	D25	D24	D22	D21	D20	D19
	Data order	DE	NA	NA	EB5	EB4	EB3	EB2
LVDS Channel E3	LVDS output	D23	D17	D16	D11	D10	D5	D27
	Data order	NA	EB7	EB6	EG7	EG6	ER7	ER6



**Approval**

5.3 BACKLIGHT UNIT

Pin	Symbol	Description	Remark
1	HV	High Voltage	Pink
2	LV	Low Voltage	White

1	HV	High Voltage	Blue
2	LV	Low Voltage	Black

Note (1) Connector Part No.: YEONHO 35001 HS-02L or equivalent

Note (2) User's connector Part No.: YEONHO 35001 WR-02L or equivalent

5.4 COLOR DATA INPUT ASSIGNMENT

The brightness of each primary color (red, green and blue) is based on the 8-bit gray scale data input for the color. The higher the binary input, the brighter the color. The table below provides the assignment of color versus data input.

Color		Data Signal																							
		Red								Green								Blue							
		R7	R6	R5	R4	R3	R2	R1	R0	R7	R6	G5	G4	G3	G2	G1	G0	R7	R6	B5	B4	B3	B2	B1	B0
Basic Colors	Black	0	0	0	0	0	0	0	0	0	0	0	0	0	0	0	0	0	0	0	0	0	0	0	0
	Red	1	1	1	1	1	1	1	1	0	0	0	0	0	0	0	0	0	0	0	0	0	0	0	0
	Green	0	0	0	0	0	0	0	0	1	1	1	1	1	1	1	1	0	0	0	0	0	0	0	0
	Blue	0	0	0	0	0	0	0	0	0	0	0	0	0	0	0	0	1	1	1	1	1	1	1	1
	Cyan	0	0	0	0	0	0	0	0	1	1	1	1	1	1	1	1	1	1	1	1	1	1	1	1
	Magenta	1	1	1	1	1	1	1	1	0	0	0	0	0	0	0	0	1	1	1	1	1	1	1	1
	Yellow	1	1	1	1	1	1	1	1	1	1	1	1	1	1	1	1	0	0	0	0	0	0	0	0
	White	1	1	1	1	1	1	1	1	1	1	1	1	1	1	1	1	1	1	1	1	1	1	1	1
Gray Scale Of Red	Red(0) / Dark	0	0	0	0	0	0	0	0	0	0	0	0	0	0	0	0	0	0	0	0	0	0	0	0
	Red(1)	0	0	0	0	0	0	0	1	0	0	0	0	0	0	0	0	0	0	0	0	0	0	0	0
	Red(2)	0	0	0	0	0	0	1	0	0	0	0	0	0	0	0	0	0	0	0	0	0	0	0	0
	⋮	⋮	⋮	⋮	⋮	⋮	⋮	⋮	⋮	⋮	⋮	⋮	⋮	⋮	⋮	⋮	⋮	⋮	⋮	⋮	⋮	⋮	⋮	⋮	⋮
	⋮	⋮	⋮	⋮	⋮	⋮	⋮	⋮	⋮	⋮	⋮	⋮	⋮	⋮	⋮	⋮	⋮	⋮	⋮	⋮	⋮	⋮	⋮	⋮	⋮
	⋮	⋮	⋮	⋮	⋮	⋮	⋮	⋮	⋮	⋮	⋮	⋮	⋮	⋮	⋮	⋮	⋮	⋮	⋮	⋮	⋮	⋮	⋮	⋮	⋮
	Red(253)	1	1	1	1	1	1	0	1	0	0	0	0	0	0	0	0	0	0	0	0	0	0	0	0
	Red(254)	1	1	1	1	1	1	1	0	0	0	0	0	0	0	0	0	0	0	0	0	0	0	0	0
Red(255)	1	1	1	1	1	1	1	0	0	0	0	0	0	0	0	0	0	0	0	0	0	0	0	0	
Gray Scale Of Green	Green(0) / Dark	0	0	0	0	0	0	0	0	0	0	0	0	0	0	0	0	0	0	0	0	0	0	0	0
	Green(1)	0	0	0	0	0	0	0	0	0	0	0	0	0	0	1	0	0	0	0	0	0	0	0	0
	Green(2)	0	0	0	0	0	0	0	0	0	0	0	0	0	1	0	0	0	0	0	0	0	0	0	0
	⋮	⋮	⋮	⋮	⋮	⋮	⋮	⋮	⋮	⋮	⋮	⋮	⋮	⋮	⋮	⋮	⋮	⋮	⋮	⋮	⋮	⋮	⋮	⋮	⋮
	⋮	⋮	⋮	⋮	⋮	⋮	⋮	⋮	⋮	⋮	⋮	⋮	⋮	⋮	⋮	⋮	⋮	⋮	⋮	⋮	⋮	⋮	⋮	⋮	⋮
	⋮	⋮	⋮	⋮	⋮	⋮	⋮	⋮	⋮	⋮	⋮	⋮	⋮	⋮	⋮	⋮	⋮	⋮	⋮	⋮	⋮	⋮	⋮	⋮	⋮
	Green(253)	0	0	0	0	0	0	0	1	1	1	1	1	1	1	0	1	0	0	0	0	0	0	0	0
	Green(254)	0	0	0	0	0	0	0	1	1	1	1	1	1	1	0	0	0	0	0	0	0	0	0	0
Green(255)	0	0	0	0	0	0	0	1	1	1	1	1	1	1	1	0	0	0	0	0	0	0	0	0	
Gray Scale Of Blue	Blue(0) / Dark	0	0	0	0	0	0	0	0	0	0	0	0	0	0	0	0	0	0	0	0	0	0	0	0
	Blue(1)	0	0	0	0	0	0	0	0	0	0	0	0	0	0	0	0	0	0	0	0	0	0	0	1
	Blue(2)	0	0	0	0	0	0	0	0	0	0	0	0	0	0	0	0	0	0	0	0	0	0	1	0
	⋮	⋮	⋮	⋮	⋮	⋮	⋮	⋮	⋮	⋮	⋮	⋮	⋮	⋮	⋮	⋮	⋮	⋮	⋮	⋮	⋮	⋮	⋮	⋮	⋮
	⋮	⋮	⋮	⋮	⋮	⋮	⋮	⋮	⋮	⋮	⋮	⋮	⋮	⋮	⋮	⋮	⋮	⋮	⋮	⋮	⋮	⋮	⋮	⋮	⋮
	⋮	⋮	⋮	⋮	⋮	⋮	⋮	⋮	⋮	⋮	⋮	⋮	⋮	⋮	⋮	⋮	⋮	⋮	⋮	⋮	⋮	⋮	⋮	⋮	⋮
	Blue(253)	0	0	0	0	0	0	0	0	0	0	0	0	0	0	0	1	1	1	1	1	1	1	0	1
	Blue(254)	0	0	0	0	0	0	0	0	0	0	0	0	0	0	0	1	1	1	1	1	1	1	1	0
Blue(255)	0	0	0	0	0	0	0	0	0	0	0	0	0	0	0	1	1	1	1	1	1	1	1	1	

Note (1) 0: Low Level Voltage, 1: High Level Voltage

## 6. INTERFACE TIMING

### 6.1 INPUT SIGNAL TIMING SPECIFICATIONS

The input signal timing specifications are shown as the following table and timing diagram.

Signal	Item	Symbol	Min.	Typ.	Max.	Unit	Note
LVDS Clock	Frequency	Fc	40	44.5	61	MHz	-
	Period	Tc	16.4	22.5	28.6	ns	-
	High Time	Tch	-	4/7	-	Tc	-
	Low Time	Tcl	-	3/7	-	Tc	-
LVDS Data	Setup Time	Tlvs	600	-	-	ps	-
	Hold Time	Tlvh	600	-	-	ps	-
Vertical Active Display Term	Frame Rate	Fr	47	60	75	Hz	Tv=Tvd+Tvb
	Total	Tv	905	926	1200	Th	-
	Display	Tvd	900	900	900	Th	-
	Blank	Tvb	Tv-Tvd	26	Tv-Tvd	Th	-
Horizontal Active Display Term	Total	Th	770	800	960	Tc	Th=Thd+Thb
	Display	Thd	720	720	720	Tc	-
	Blank	Thb	Th-Thd	80	Th-Thd	Tc	-

Note: Because this module is operated by DE only mode, Hsync and Vsync input signals should be set to low logic level or ground. Otherwise, this module would operate abnormally.

#### INPUT SIGNAL TIMING DIAGRAM

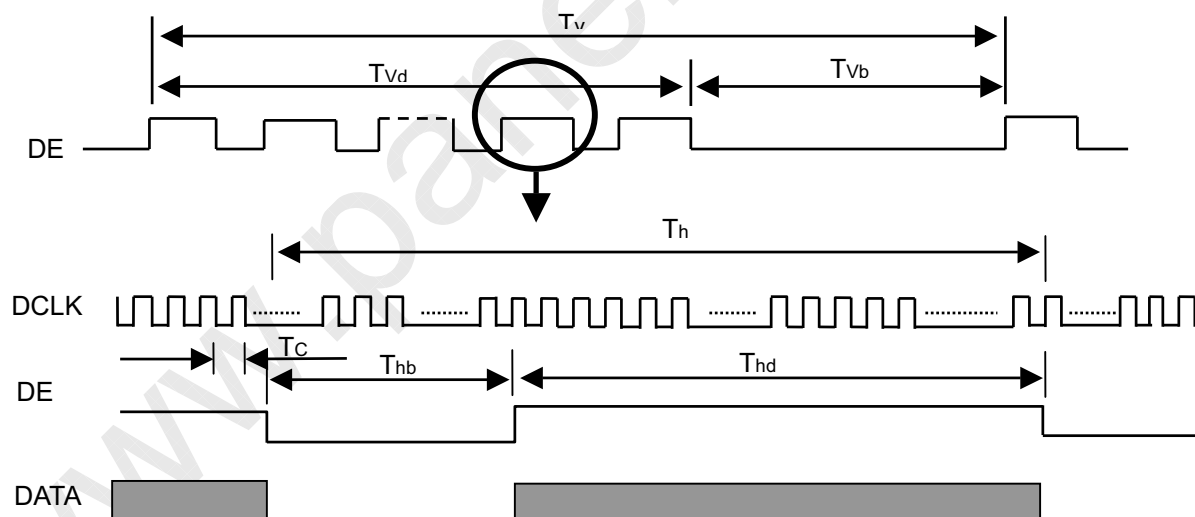

## 6.2 POWER ON/OFF SEQUENCE

To prevent a latch-up or DC operation of LCD module, the power on/off sequence should be as the diagram below.

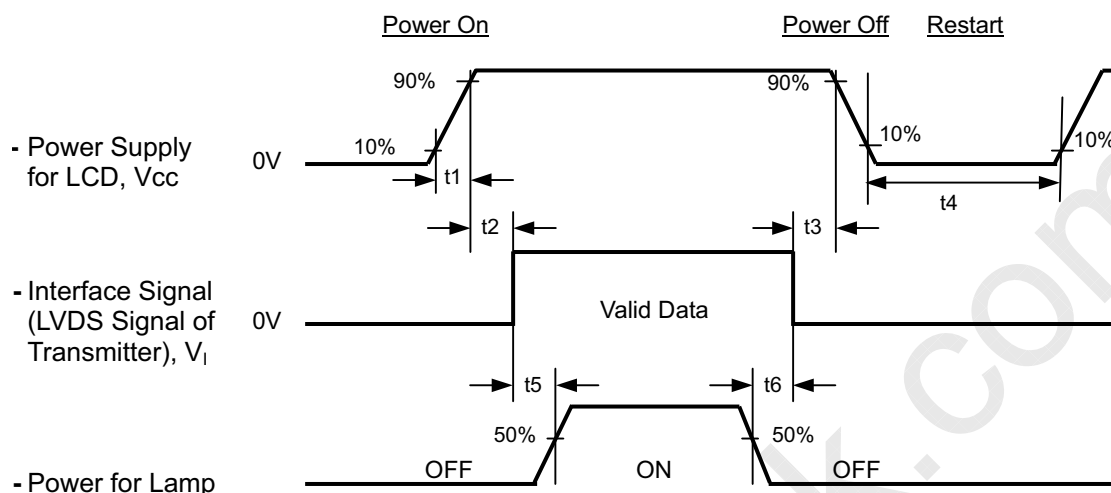

### Timing Specifications:

$$0.5 < t_1 \leq 10 \text{ msec}$$

$$0 < t_2 \leq 50 \text{ msec}$$

$$0 < t_3 \leq 50 \text{ msec}$$

$$t_4 \geq 500 \text{ msec}$$

$$t_5 \geq 450 \text{ msec}$$

$$t_6 \geq 90 \text{ msec}$$

### Note.

- (1) The supply voltage of the external system for the module input should be the same as the definition of V<sub>cc</sub>.
- (2) Apply the lamp voltage within the LCD operation range. When the backlight turns on before the LCD operation of the LCD turns off before the backlight turns off, the display may momentarily become abnormal screen.
- (3) In case of V<sub>cc</sub> = off level, please keep the level of input signals on the low or keep a high impedance.
- (4) T<sub>4</sub> should be measured after the module has been fully discharged between power off and on period.
- (5) Interface signal shall not be kept at high impedance when the power is on.



## 7. OPTICAL CHARACTERISTICS

### 7.1 TEST CONDITIONS

Item	Symbol	Value	Unit
Ambient Temperature	Ta	25±2	°C
Ambient Humidity	Ha	50±10	%RH
Supply Voltage	V <sub>CC</sub>	5.0	V
Input Signal	According to typical value in "3. ELECTRICAL CHARACTERISTICS"		
Lamp Current	I <sub>L</sub>	7.0	mA
Inverter Operating Frequency	F <sub>L</sub>	55	KHz
Inverter	Darfon VK.13165.101		

### 7.2 OPTICAL SPECIFICATIONS

The relative measurement methods of optical characteristics are shown in 7.2. The following items should be measured under the test conditions described in 7.1 and stable environment shown in Note (5).

Item	Symbol	Condition	Min.	Typ.	Max.	Unit	Note		
Color Chromaticity	Red	$\theta_x=0^\circ, \theta_y=0^\circ$ CS-1000T	Typ - 0.035	Typ + 0.035			(1), (5)		
								Rx	0.669
	Ry							0.319	
	Green							Gx	0.197
								Gy	0.684
	Blue							Bx	0.152
								By	0.079
	White							Wx	0.321
Wy		0.329							
Center Luminance of White	L <sub>C</sub>		220	280	---	cd/m <sup>2</sup>	(4), (5)		
Contrast Ratio	CR		630	1000	---	-	(2), (5)		
Response Time	T <sub>R</sub>	$\theta_x=0^\circ, \theta_y=0^\circ$	---	1.5	6.5	ms	(3)		
	T <sub>F</sub>							3.5	8.5
White Variation	δW	$\theta_x=0^\circ, \theta_y=0^\circ$	---	1.3	1.5	-	(5), (6)		
Viewing Angle	Horizontal	CR ≥ 10		75	85	---	Deg.	(1), (5)	
									θ <sub>x+</sub>
	θ <sub>x-</sub>								
	Vertical								θ <sub>y+</sub>
θ <sub>y-</sub>		70	80	---					

Note (1) Definition of Viewing Angle ( $\theta_x, \theta_y$ ):

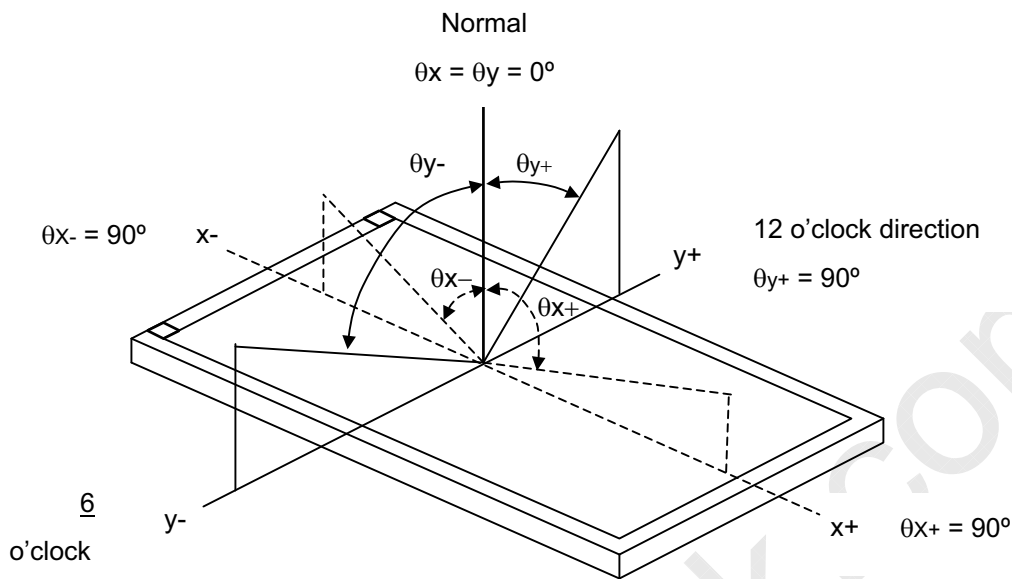

Note (2) Definition of Contrast Ratio (CR):

The contrast ratio can be calculated by the following expression.

$$\text{Contrast Ratio (CR)} = L_{255} / L_0$$

L255: Luminance of gray level 255

L 0: Luminance of gray level 0

$$\text{CR} = \text{CR} (1)$$

CR (X) is corresponding to the Contrast Ratio of the point X at Figure in Note (6).

Note (3) Definition of Response Time ( $T_R, T_F$ ):

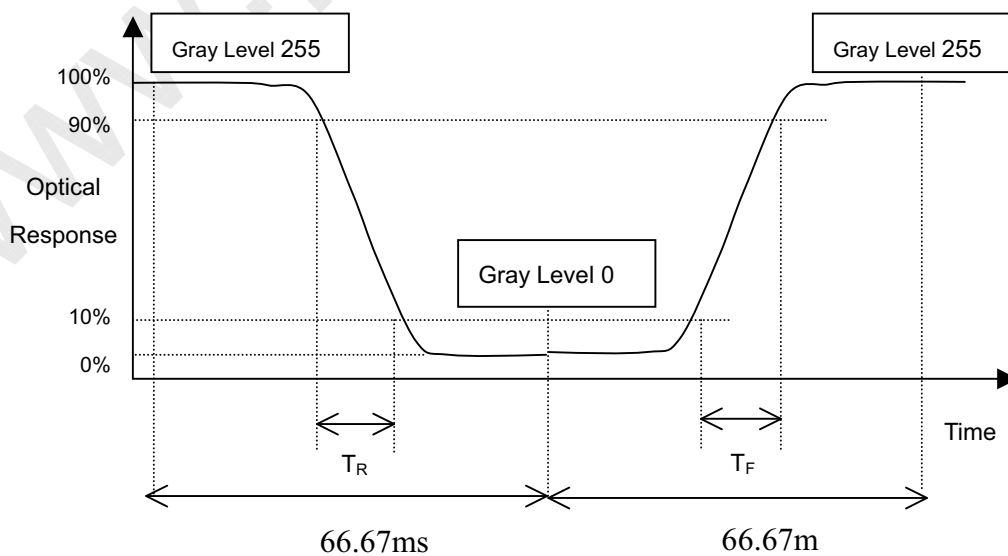

Note (4) Definition of Luminance of White ( $L_C$ ):

Measure the luminance of gray level 255 at center point

$$L_C = L(1)$$

$L(x)$  is corresponding to the luminance of the point X at Figure in Note (6).

Note (5) Measurement Setup:

The LCD module should be stabilized at given temperature for 40 minutes to avoid abrupt temperature change during measuring. In order to stabilize the luminance, the measurement should be executed after lighting Backlight for 40 minutes in a windless room.

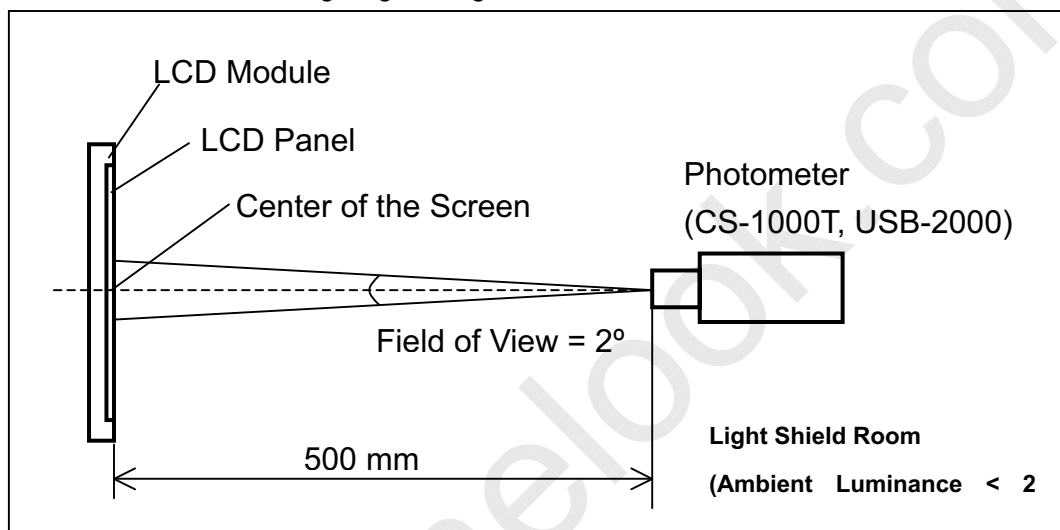

Note (6) Definition of White Variation ( $\delta W$ ):

Measure the luminance of gray level 255 at 9 points

$$\delta W = \text{Maximum} [L(1), L(2) \dots L(4), L(9)] / \text{Minimum} [L(1), L(2) \dots L(4), L(9)]$$

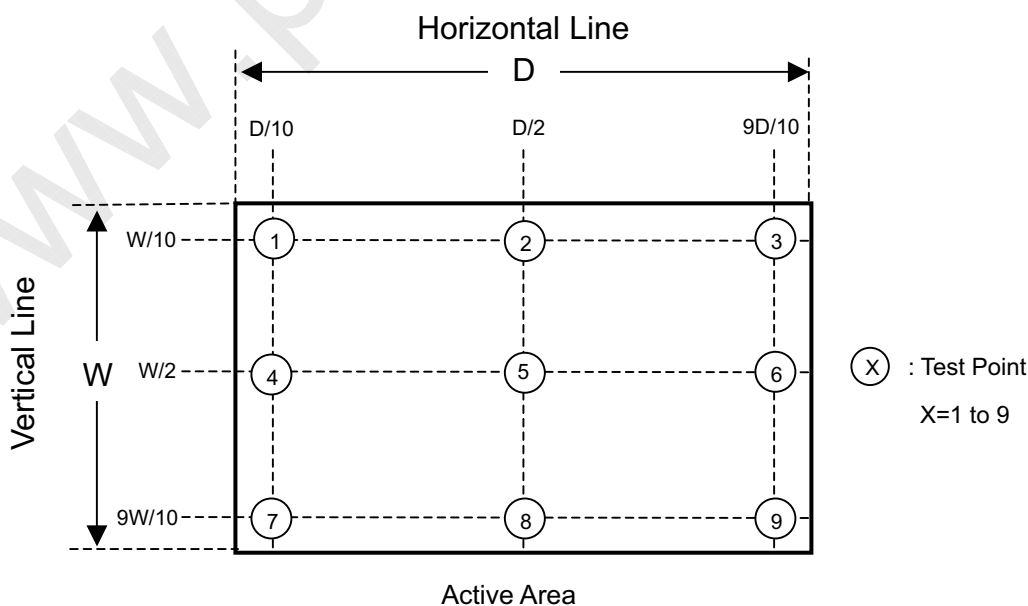

## 8. PACKAGING

### 8.1 PACKING SPECIFICATIONS

- (1) 7 LCD modules / 1 Box
- (2) Box dimensions: 525(L) X 300 (W) X 360 (H) mm
- (3) Weight: approximately 15.19 Kg (7 modules per box)

### 8.2 PACKING METHOD

- (1) Carton Packing should have no failure in the following reliability test items.

Test Item	Test Conditions	Note
Vibration	ISTA STANDARD Random, Frequency Range: 1 – 200 Hz Top & Bottom: 30 minutes (+Z), 10 min (-Z), Right & Left: 10 minutes (X) Back & Forth 10 minutes (Y)	Non Operation
Dropping Test	1 Corner, 3 Edge, 6 Face, 61cm	Non Operation

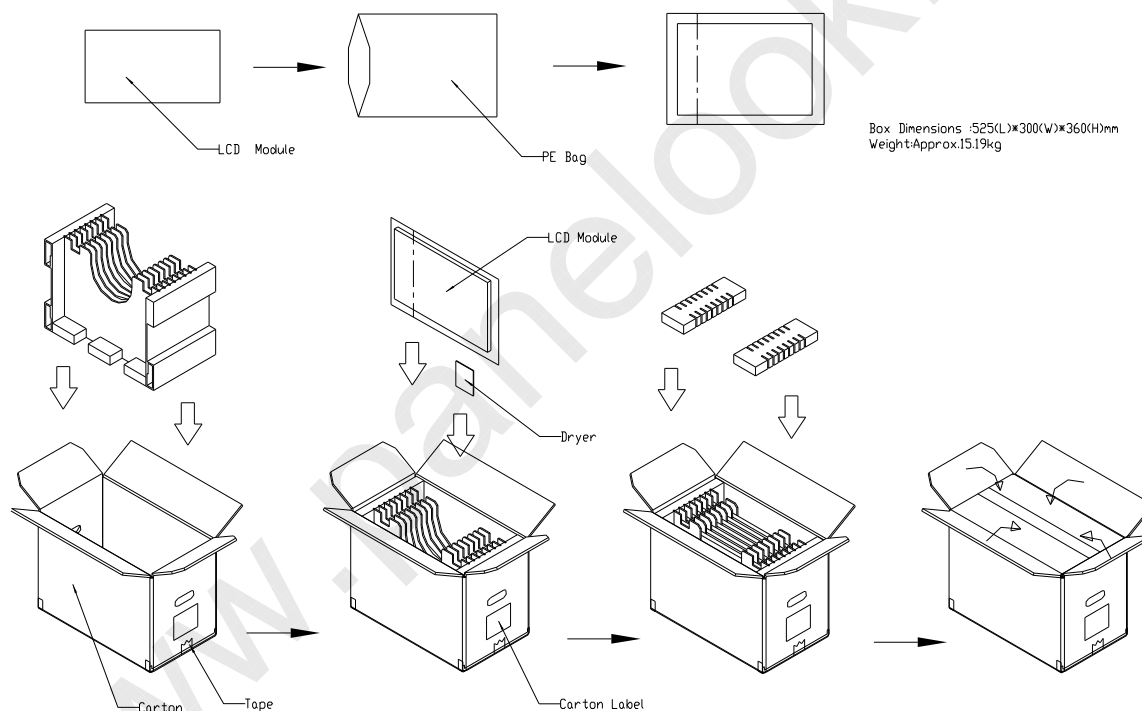

Figure. 8-1 Packing method



Approval

For ocean shipping

Sea / Land Transportation (40ft HQ Container)

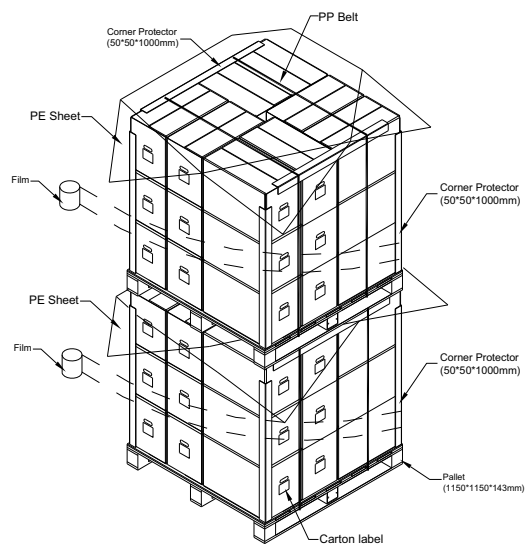

Sea / Land Transportation (40ft Container)

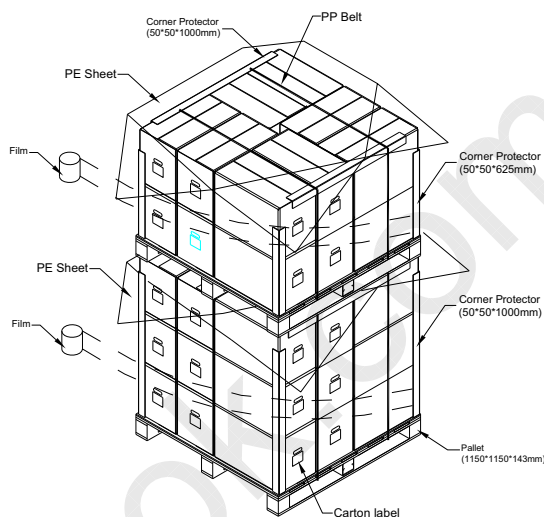

Figure. 8-2 Packing method

For air transport

Air Transportation

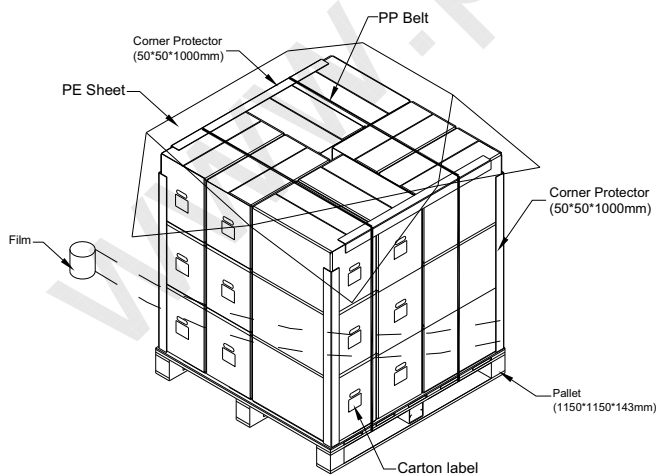
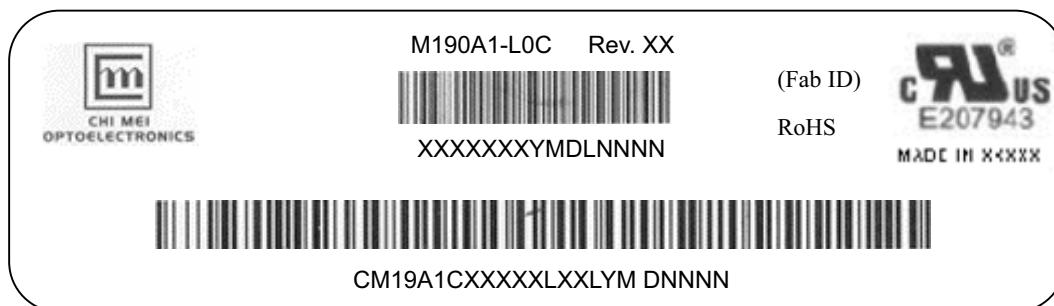

Figure. 8-3 Packing method

## 9. DEFINITION OF LABELS

### 9.1 CMO MODULE LABEL

The barcode nameplate is pasted on each module as illustration, and its definitions are as following explanation.



- (a) Model Name: M190A1-LOC  
 (b) Revision: Rev. XX, for example: A0, A1... B1, B2... or C1, C2...etc.  
 (c) CMO barcode definition:

Serial ID: XX-XX-X-XX-YMD-L-NNNN

Code	Meaning	Description
XX	CMO internal use	-
XX	Revision	Cover all the change
X	CMO internal use	-
YMD	Year, month, day	Year: 2001=1, 2002=2, 2003=3, 2004=4... Month: 1~12=1, 2, 3, ~, 9, A, B, C Day: 1~31=1, 2, 3, ~, 9, A, B, C, ~, W, X, Y, exclude I, O, and U.
L	Product line #	Line 1=1, Line 2=2, Line 3=3, ...
NNNN	Serial number	Manufacturing sequence of product

- (d) Customer's barcode definition:

Serial ID: CM-19A1C-X-X-X-XX-L-XX-L-YMD-NNNN

Code	Meaning	Description
CM	Supplier code	CMO=CM
19A1C	Model number	M190A1-L0C=19A1C
X	Revision code	Non ZBD: 1,2,~,8,9 / ZBD: A~Z
X	Source driver IC code	Century=1, CLL=2, Demos=3, Epson=4, Fujitsu=5, Himax=6, Hitachi=7, Hynix=8, LDI=9, Matsushita=A, NEC=B, Novatec=C, OKI=D, Philips=E, Renasas=F, Samsung=G, Sanyo=H, Sharp=I, TI=J, Topro=K, Toshiba=L, Windbond=M
X	Gate driver IC code	
XX	Cell location	Tainan, Taiwan=TN
L	Cell line #	1,2,~,9,A,B,~,Y,Z
XX	Module location	Tainan, Taiwan=TN ; Ningbo China=NP
L	Module line #	1,2,~,9,A,B,~,Y,Z
YMD	Year, month, day	Year: 2001=1, 2002=2, 2003=3, 2004=4... Month: 1~12=1, 2, 3, ~, 9, A, B, C Day: 1~31= 1, 2, 3, ~, 9, A, B, C, ~, T, U, V
NNNN	Serial number	Manufacturing sequence of product

- (e) UL Factory ID:

Region	Factory ID
TWCMO	GEMN
NBCMO	LEOO
NBCME	CANO

NHCMO | CAPG

## 10. PRECAUTIONS

### 10.1 ASSEMBLY AND HANDLING PRECAUTIONS

- (1) Do not apply rough force such as bending or twisting to the module during assembly.
- (2) To assemble or install module into user's system can be only in clean working areas. The dust and oil may cause electrical short or worsen the polarizer.
- (3) It's not permitted to have pressure or impulse on the module because the LCD panel and Backlight will be damaged.
- (4) Always follow the correct power sequence when LCD module is connecting and operating. This can prevent damage to the CMOS LSI chips during latch-up.
- (5) Do not pull the I/F connector in or out while the module is operating.
- (6) Do not disassemble the module.
- (7) Use a soft dry cloth without chemicals for cleaning, because the surface of polarizer is very soft and easily scratched.
- (8) It is dangerous that moisture come into or contacted the LCD module, because moisture may damage LCD module when it is operating.
- (9) High temperature or humidity may reduce the performance of module. Please store LCD module within the specified storage conditions.
- (10) When ambient temperature is lower than 10°C may reduce the display quality. For example, the response time will become slowly, and the starting voltage of CCFL will be higher than room temperature.

### 10.2 SAFETY PRECAUTIONS

- (1) The startup voltage of Backlight is approximately 1000 Volts. It may cause electrical shock while assembling with inverter. Do not disassemble the module or insert anything into the Backlight unit.
- (2) If the liquid crystal material leaks from the panel, it should be kept away from the eyes or mouth. In case of contact with hands, skin or clothes, it has to be washed away thoroughly with soap.
- (3) After the module's end of life, it is not harmful in case of normal operation and storage.

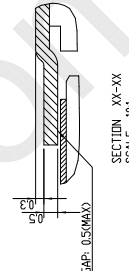
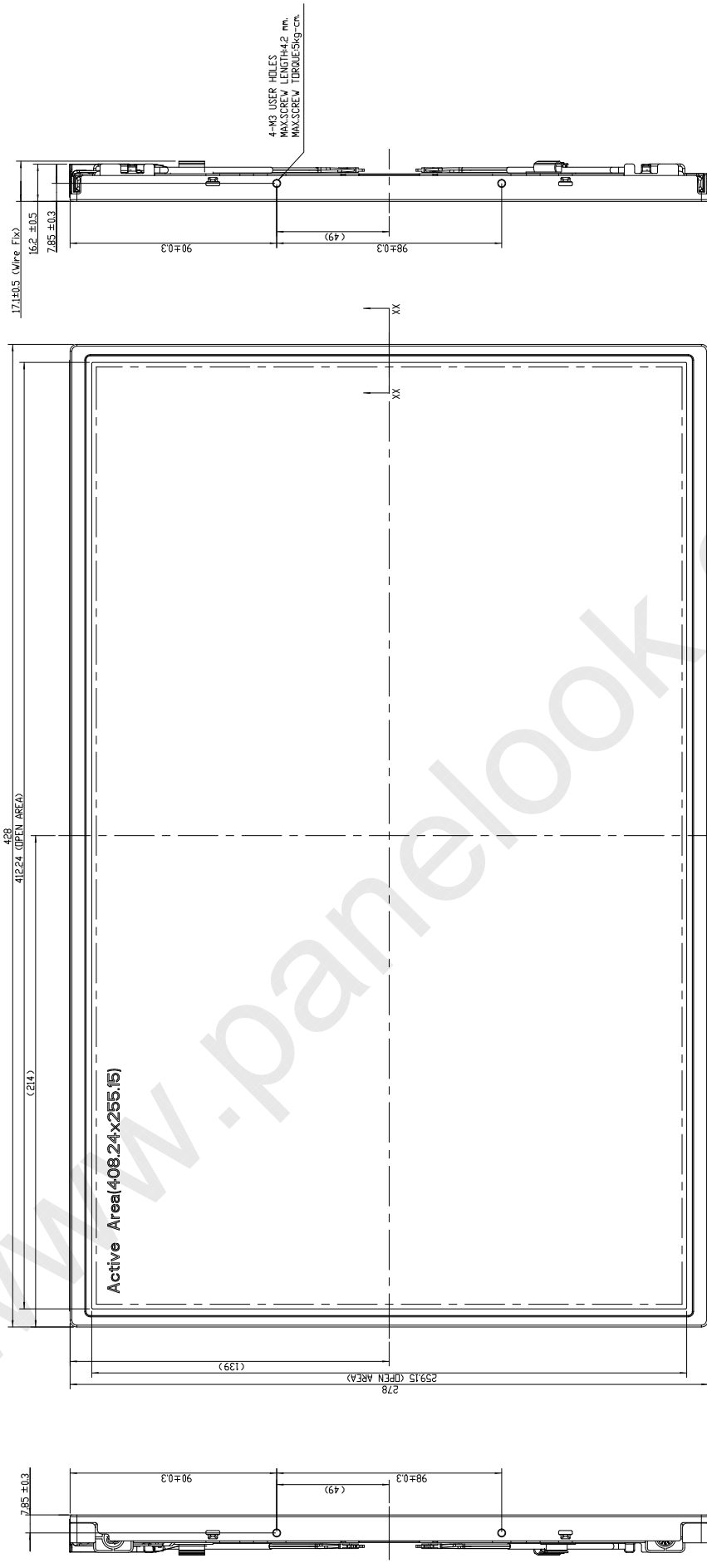

NOTES:  
 1. OUTLINE TOLERANCE: ±0.5mm  
 2. \* MARKS THE DESIGN CRITICAL DIMENSION.  
 3. @ MARKS THE PROCESS CRITICAL DIMENSION.  
 4. 1.7 CONECTOR SPEC: JE-FF-X30SL-HP on STY MSKAKT2407P30A  
 5. 1.7 CONECTOR SPEC: JE-FF-X30SL-HP on STY MSKAKT2407P30A  
 6. Fit and position disposition tolerance of display area  
 are as following:  
 (Y) Y-direction: IA-BI < 1mm  
 (X) X-direction: IC-DI < 1mm

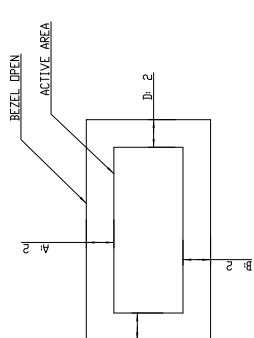

TITLE	ASSY MODULE_H99AL_10A	ED. REV./A	ED. REV./119
Approved	TIGER CHANG	Drawing No.	H99AE10A
Checked	AIDEN WAN	Part No.	TBD
Drawer	TIBBIAS WANG	Material	TBD
Designer	TIBBIAS WANG	Date	17-Jun-2006
		Scale	1:1
		Sheet	1 / 2
		Part	11
		Uprtime	0

Mark	Description	Date	Changed By/Approved By	ECN No.	Remark



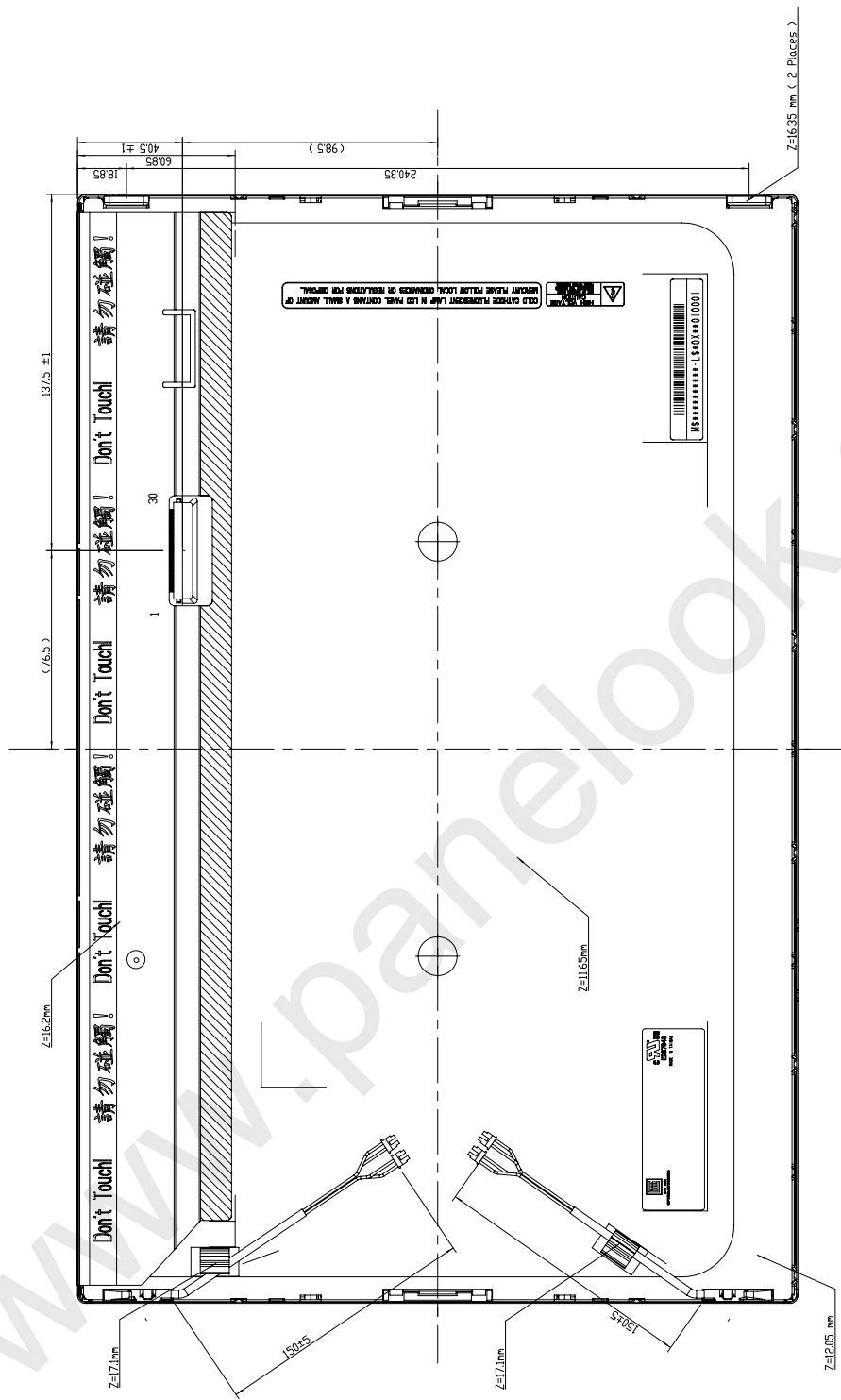

NOTES: 1. OUTLINE TOLERANCE: ±0.5mm.  
 2. \* MARKS THE DESIGN CRITICAL DIMENSION.  
 3. \* @ MARKS THE PROCESS CRITICAL DIMENSION.  
 4. I/F CONNECTOR SPEC: JAE-F1-X30SS-4F or STM-MSAKT2407P30A.  
 SLAMP CONNECTOR SPEC: FEDNHQ 3500HS-02L OR EQUIVALENT.

TITLE	W557_MIDDLE_MPANEL_L04	ED REV. 1/A
Approved	TIGER CHANG	ED REV. 1/B
Checked	AILEN WAN	MOCK-010A
Drawer	DOBAS WANG	Part No. EBD
Designer	DOBAS WANG	Sheet 12 / 21 AI
		Date 12-Nov-2006 Scale 1:1 Unit:mm

CHI MEI	
CHI MEI ELECTRONICS CORP.	
ALL RIGHTS RESERVED. COPYRIGHT FUBANDA.	

Mark	Description	Date	Changed By	Approved By	ECN No.	Remark