

TFT LCD Approval Specification

MODEL NO.: M190A1-P02

Customer : _____

Approved by : _____

Note :

記錄	工作	審核	角色	投票
2007-01-23 13:32:04 CST	Approve by Dept. Mgr.(QA RA)	ys_lai(賴育賢 /54881/52755/43154)	Department Manager(QA RA)	Accept
2007-01-18 19:29:53 CST	Approve by Director	teren_lin(林添仁 /56910/36064)	Director	Accept

- CONTENTS -

REVISION HISTORY	3
1. GENERAL DESCRIPTION	4
1.1 OVERVIEW	
1.2 FEATURES	
1.3 APPLICATION	
1.4 GENERAL SPECIFICATIONS	
1.5 MECHANICAL SPECIFICATIONS	
2. ABSOLUTE MAXIMUM RATINGS	5
2.1 ABSOLUTE RATINGS OF ENVIRONMENT (BASED ON CMO MODULE M190A1-L02)	
2.2 ABSOLUTE RATINGS OF ENVIRONMENT (OPEN CELL)	
2.3 ELECTRICAL ABSOLUTE RATINGS (OPEN CELL)	
3. ELECTRICAL CHARACTERISTICS	7
3.1 TFT LCD OPEN CELL	
4. BLOCK DIAGRAM	9
4.1 TFT LCD OPEN CELL	
5. INPUT TERMINAL PIN ASSIGNMENT	10
5.1 TFT LCD MODULE	
5.2 TIMING DIAGRAM OF LVDS INPUT SIGNAL	
5.3 COLOR DATA INPUT ASSIGNMENT	
6. INTERFACE TIMING	13
6.1 INPUT SIGNAL TIMING SPECIFICATIONS	
6.2 POWER ON/OFF SEQUENCE	
7. OPTICAL CHARACTERISTICS	15
7.1 TEST CONDITIONS	
7.2 OPTICAL SPECIFICATIONS	
7.3 FLICKER ADJUSTMENT	
8. PACKAGING	20
8.1 PACKING SPECIFICATIONS	
8.2 PACKING METHOD	
9. DEFINITION OF LABELS	22
9.1 OPEN CELL LABEL	
9.2 CARTON LABEL	
10. PRECAUTIONS	24
10.1 ASSEMBLY AND HANDLING PRECAUTIONS	
10.2 SAFETY PRECAUTIONS	
11. MECHANICAL DRAWING	25

REVISION HISTORY

Version	Date	Section	Description
Ver. 1.0	Mar, 24 '06	-	M190A1-P02 Preliminary Specifications was first issued.
Ver. 3.1	Aug, 29 '06	7.2	Color chromaticity: Typ, (Gcx,Gcy): (0.274,0.673) (0.274,0.589); (Bcx,Bcy): (0.164,0.101) (0.148,0.101); (Wcx,Wcy): (0.320,0.334) (0.320,0.356)
Ver. 3.2	Nov, 27 '06	9.1	Modified CMO OPEN CELL LABEL.
Ver. 3.3	Jan, 18 '07	1.4	Display Colors: 16.2M -> 16.7M

1. GENERAL DESCRIPTION

1.1 OVERVIEW

The M190A1-P02 is a 19-inch wide TFT LCD cell with driver ICs and a 30-pins-2ch-LVDS circuit board. The product supports 1440 x 900 WXGA+ mode and can display up to 16.2M colors. The backlight unit is not built in.

1.2 FEATURES

- Super wide viewing angle
- Super High contrast ratio
- Super Fast response time
- High color saturation
- WXGA+ (1440 x 900 pixels) resolution
- DE (Data Enable) only mode
- LVDS (Low Voltage Differential Signaling) interface
- RoHS Compliance

1.3 APPLICATION

- TFT LCD Monitor
- TFT LCD TV

1.4 GENERAL SPECIFICATIONS

Item	Specification	Unit	Note
Diagonal Size	19.05	inch	-
Active Area	410.40 (H) x 256.50 (V)	mm	(1)
Driver Element	a-si TFT active matrix	-	-
Pixel Number	1440 x R.G.B. x 900	pixel	-
Pixel Pitch	0.285 (H) x 0.285 (V)	mm	-
Pixel Arrangement	RGB vertical stripe	-	-
Display Colors	16.7M	color	-
Transmissive Mode	Normally White	-	-
Surface Treatment	Hard coating (3H), Anti-glare (Haze 25%)	-	-

1.5 MECHANICAL SPECIFICATIONS

Item	Min.	Typ.	Max.	Unit	Note
Weight	-	484	500	g	-
I/F connector mounting position	The mounting inclination of the connector makes the screen center within $\pm 0.5\text{mm}$ as the horizontal.				(2)

Note (1) Please refer to the attached drawings for more information of front and back outline dimensions.

(2) Connector mounting position

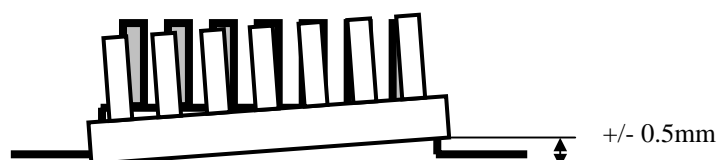

2. ABSOLUTE MAXIMUM RATINGS

2.1 ABSOLUTE RATINGS OF ENVIRONMENT (BASED ON CMO MODULE M190A1-L02)

Item	Symbol	Value		Unit	Note
		Min.	Max.		
Storage Temperature	T_{ST}	-20	+60	°C	(1)
Operating Ambient Temperature	T_{OP}	0	+50	°C	(1), (2)

Note (1) Temperature and relative humidity range is shown in the figure below.

- (a) 90 %RH Max. ($T_a \leq 40$ °C).
- (b) Wet-bulb temperature should be 39 °C Max. ($T_a > 40$ °C).
- (c) No condensation.

Note (2) The temperature of panel display surface area should be 0 °C Min. and 60 °C Max.

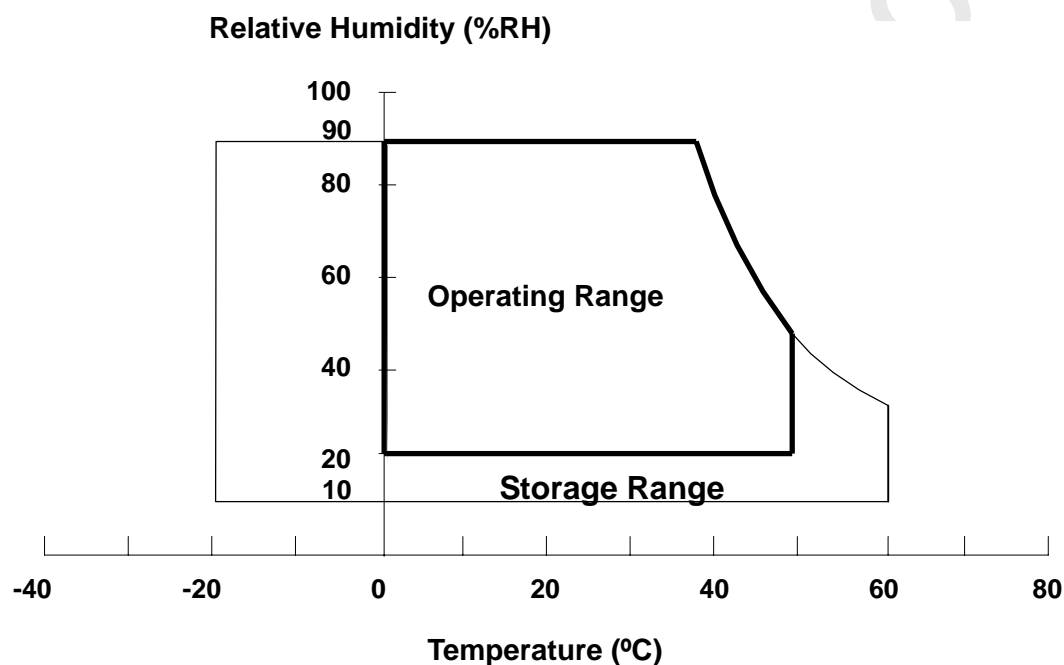

2.2 ABSOLUTE RATINGS OF ENVIRONMENT (OPEN CELL)

High temperature or humidity may reduce the performance of panel. Please store LCD panel within the specified storage conditions.

Storage Condition: With packing.

Storage temperature range: 25 ± 5 °C.

Storage humidity range: $50\pm 10\%$ RH.

Shelf life: 30days

2.3 ELECTRICAL ABSOLUTE RATINGS (OPEN CELL)

Item	Symbol	Value		Unit	Note
		Min	Max		
Power Supply Voltage	V_{CC}	-0.3	+6.0	V	(1)
Logic Input Voltage	V_{IN}	-0.3	4.3	V	

Note (1) Permanent damage might occur if the module is operated at conditions exceeding the maximum values.

3. ELECTRICAL CHARACTERISTICS

3.1 TFT LCD OPEN CELL

 $T_a = 25 \pm 2 \text{ }^\circ\text{C}$

Parameter	Symbol	Value			Unit	Note
		Min.	Typ.	Max.		
Power Supply Voltage	V _{CC}	4.5	5.0	5.5	V	-
Ripple Voltage	V _{RP}	-	-	100	mV	-
Rush Current	I _{RUSH}	-	1.6	3	A	(2)
Power Supply Current	White	-	0.5	0.7	A	(3)a
	Black	-	0.7	1.0	A	(3)b
	Vertical Stripe	-	0.7	1.0	A	(3)c
LVDS differential input voltage	V _{id}	100	-	600	mV	
LVDS common input voltage	V _{ic}	-	1.2	-	V	
Logic "L" input voltage	V _{il}	V _{SS}	-	0.8	V	

Note (1) The module should be always operated within above ranges.

Note (2) Measurement Conditions:

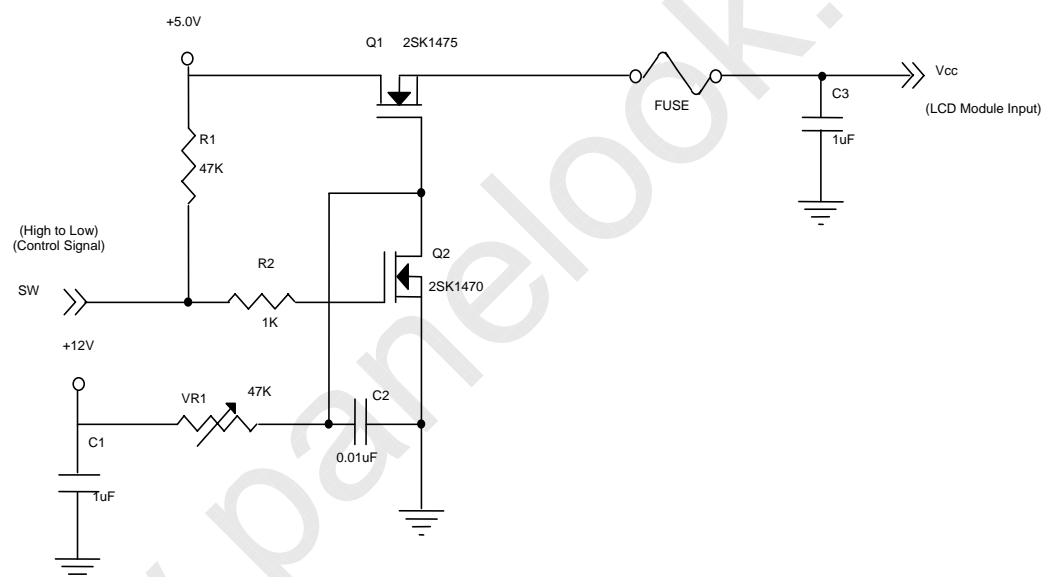

Vcc rising time is 470 μ s

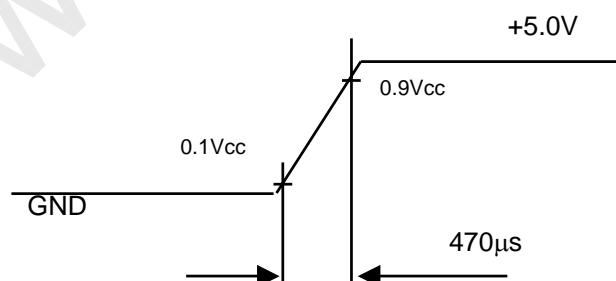

Note (3) The specified power supply current is under the conditions at $V_{cc} = 5.0\text{ V}$, $T_a = 25 \pm 2\text{ }^\circ\text{C}$, $f_v = 60\text{ Hz}$, whereas a power dissipation check pattern below is displayed.

a. White Pattern



Active Area

b. Black Pattern



Active Area

c. Vertical Stripe Pattern

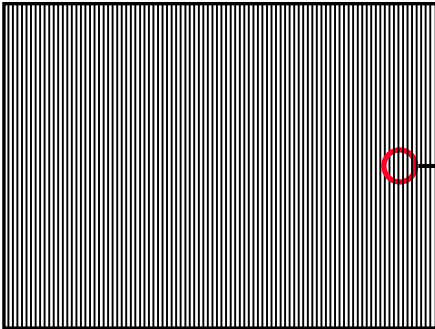

Active Area

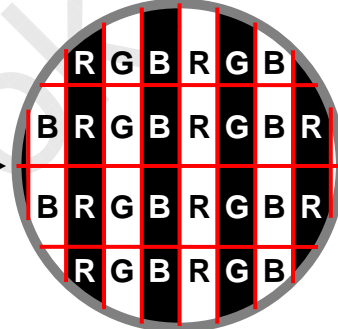

4. BLOCK DIAGRAM

4.1 TFT LCD OPEN CELL

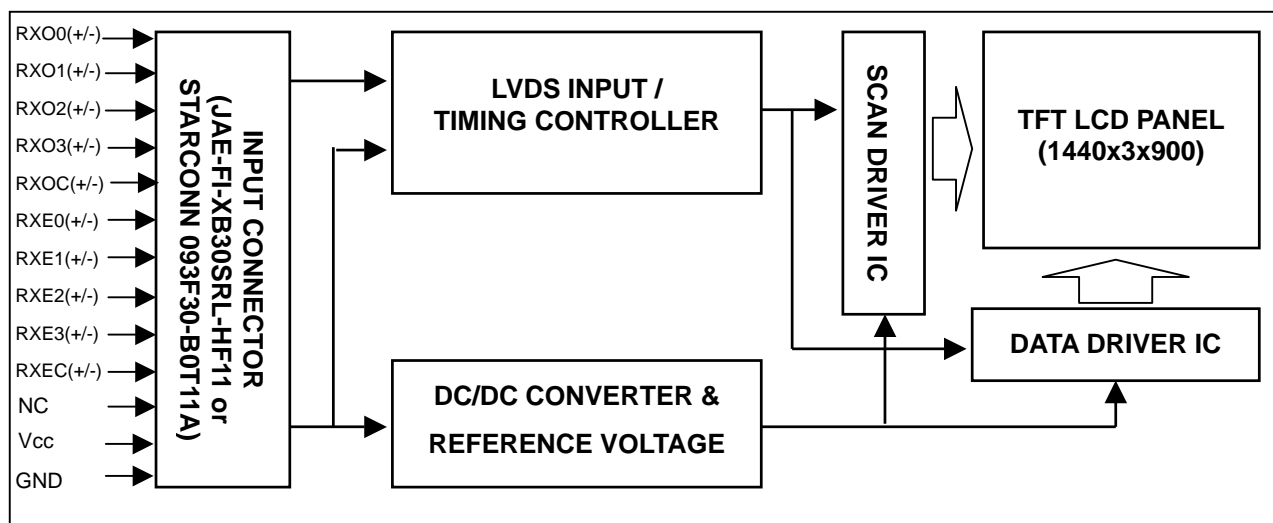

5. INPUT TERMINAL PIN ASSIGNMENT

5.1 TFT LCD MODULE

Pin	Name	Description
1	RXO0-	Negative LVDS differential data input. Channel O0 (odd)
2	RXO0+	Positive LVDS differential data input. Channel O0 (odd)
3	RXO1-	Negative LVDS differential data input. Channel O1 (odd)
4	RXO1+	Positive LVDS differential data input. Channel O1 (odd)
5	RXO2-	Negative LVDS differential data input. Channel O2 (odd)
6	RXO2+	Positive LVDS differential data input. Channel O2 (odd)
7	GND	Ground
8	RXOC-	Negative LVDS differential clock input. (odd)
9	RXOC+	Positive LVDS differential clock input. (odd)
10	RXO3-	Negative LVDS differential data input. Channel O3(odd)
11	RXO3+	Positive LVDS differential data input. Channel O3 (odd)
12	RXE0-	Negative LVDS differential data input. Channel E0 (even)
13	RXE0+	Positive LVDS differential data input. Channel E0 (even)
14	GND	Ground
15	RXE1-	Negative LVDS differential data input. Channel E1 (even)
16	RXE1+	Positive LVDS differential data input. Channel E1 (even)
17	GND	Ground
18	RXE2-	Negative LVDS differential data input. Channel E2 (even)
19	RXE2+	Positive LVDS differential data input. Channel E2 (even)
20	RXEC-	Negative LVDS differential clock input. (even)
21	RXEC+	Positive LVDS differential clock input. (even)
22	RXE3-	Negative LVDS differential data input. Channel E3 (even)
23	RXE3+	Positive LVDS differential data input. Channel E3 (even)
24	GND	Ground
25	NC	Not connection.
26	NC	Not connection.
27	NC	Not connection.
28	VCC	+5.0V power supply
29	VCC	+5.0V power supply
30	VCC	+5.0V power supply

Note (1) Connector Part No.: JAE-FI-XB30SRL-HF11 or STARCONN 093F30-B0T11A or equivalent.

Note (2) The first pixel is odd.

Note (3) Input signal of even and odd clock should be the same timing.

5.2 TIMING DIAGRAM OF LVDS INPUT SIGNAL

LVDS Channel E0	LVDS output	D7	D6	D4	D3	D2	D1	D0
	Data order	EG0	ER5	ER4	ER3	ER2	ER1	ER0
LVDS Channel E1	LVDS output	D18	D15	D14	D13	D12	D9	D8
	Data order	EB1	EB0	EG5	EG4	EG3	EG2	EG1
LVDS Channel E2	LVDS output	D26	D25	D24	D22	D21	D20	D19
	Data order	DE	NA	NA	EB5	EB4	EB3	EB2
LVDS Channel E3	LVDS output	D23	D17	D16	D11	D10	D5	D27
	Data order	NA	EB7	EB6	EG7	EG6	ER7	ER6
LVDS Channel O0	LVDS output	D7	D6	D4	D3	D2	D1	D0
	Data order	OG0	OR5	OR4	OR3	OR2	OR1	OR0
LVDS Channel O1	LVDS output	D18	D15	D14	D13	D12	D9	D8
	Data order	OB1	OB0	OG5	OG4	OG3	OG2	OG1
LVDS Channel O2	LVDS output	D26	D25	D24	D22	D21	D20	D19
	Data order	DE	NA	NA	OB5	OB4	OB3	OB2
LVDS Channel O3	LVDS output	D23	D17	D16	D11	D10	D5	D27
	Data order	NA	OB7	OB6	OG7	OG6	OR7	OR6



Approval

5.3 COLOR DATA INPUT ASSIGNMENT

The brightness of each primary color (red, green and blue) is based on the 8-bit gray scale data input for the color. The higher the binary input, the brighter the color. The table below provides the assignment of color versus data input.

Color		Data Signal																							
		Red								Green						Blue									
		R7	R6	R5	R4	R3	R2	R1	R0	R7	R6	G5	G4	G3	G2	G1	G0	R7	R6	B5	B4	B3	B2	B1	B0
Basic Colors	Black	0	0	0	0	0	0	0	0	0	0	0	0	0	0	0	0	0	0	0	0	0	0	0	0
	Red	1	1	1	1	1	1	1	1	0	0	0	0	0	0	0	0	0	0	0	0	0	0	0	0
	Green	0	0	0	0	0	0	0	0	1	1	1	1	1	1	1	1	0	0	0	0	0	0	0	0
	Blue	0	0	0	0	0	0	0	0	0	0	0	0	0	0	0	0	1	1	1	1	1	1	1	1
	Cyan	0	0	0	0	0	0	0	0	1	1	1	1	1	1	1	1	1	1	1	1	1	1	1	1
	Magenta	1	1	1	1	1	1	1	1	0	0	0	0	0	0	0	0	1	1	1	1	1	1	1	1
	Yellow	1	1	1	1	1	1	1	1	1	1	1	1	1	1	1	1	0	0	0	0	0	0	0	0
	White	1	1	1	1	1	1	1	1	1	1	1	1	1	1	1	1	1	1	1	1	1	1	1	1
Gray Scale Of Red	Red(0) / Dark	0	0	0	0	0	0	0	0	0	0	0	0	0	0	0	0	0	0	0	0	0	0	0	0
	Red(1)	0	0	0	0	0	0	0	1	0	0	0	0	0	0	0	0	0	0	0	0	0	0	0	0
	Red(2)	0	0	0	0	0	0	1	0	0	0	0	0	0	0	0	0	0	0	0	0	0	0	0	0
	⋮	⋮	⋮	⋮	⋮	⋮	⋮	⋮	⋮	⋮	⋮	⋮	⋮	⋮	⋮	⋮	⋮	⋮	⋮	⋮	⋮	⋮	⋮	⋮	⋮
	⋮	⋮	⋮	⋮	⋮	⋮	⋮	⋮	⋮	⋮	⋮	⋮	⋮	⋮	⋮	⋮	⋮	⋮	⋮	⋮	⋮	⋮	⋮	⋮	⋮
	⋮	⋮	⋮	⋮	⋮	⋮	⋮	⋮	⋮	⋮	⋮	⋮	⋮	⋮	⋮	⋮	⋮	⋮	⋮	⋮	⋮	⋮	⋮	⋮	⋮
	Red(253)	1	1	1	1	1	1	0	1	0	0	0	0	0	0	0	0	0	0	0	0	0	0	0	0
	Red(254)	1	1	1	1	1	1	1	0	0	0	0	0	0	0	0	0	0	0	0	0	0	0	0	0
Red(255)	1	1	1	1	1	1	1	1	0	0	0	0	0	0	0	0	0	0	0	0	0	0	0	0	
Gray Scale Of Green	Green(0) / Dark	0	0	0	0	0	0	0	0	0	0	0	0	0	0	0	0	0	0	0	0	0	0	0	0
	Green(1)	0	0	0	0	0	0	0	0	0	0	0	0	0	0	1	0	0	0	0	0	0	0	0	0
	Green(2)	0	0	0	0	0	0	0	0	0	0	0	0	0	1	0	0	0	0	0	0	0	0	0	0
	⋮	⋮	⋮	⋮	⋮	⋮	⋮	⋮	⋮	⋮	⋮	⋮	⋮	⋮	⋮	⋮	⋮	⋮	⋮	⋮	⋮	⋮	⋮	⋮	⋮
	⋮	⋮	⋮	⋮	⋮	⋮	⋮	⋮	⋮	⋮	⋮	⋮	⋮	⋮	⋮	⋮	⋮	⋮	⋮	⋮	⋮	⋮	⋮	⋮	⋮
	⋮	⋮	⋮	⋮	⋮	⋮	⋮	⋮	⋮	⋮	⋮	⋮	⋮	⋮	⋮	⋮	⋮	⋮	⋮	⋮	⋮	⋮	⋮	⋮	⋮
	Green(253)	0	0	0	0	0	0	0	1	1	1	1	1	1	1	0	1	0	0	0	0	0	0	0	0
	Green(254)	0	0	0	0	0	0	0	1	1	1	1	1	1	1	0	0	0	0	0	0	0	0	0	0
Green(255)	0	0	0	0	0	0	0	1	1	1	1	1	1	1	1	0	0	0	0	0	0	0	0	0	
Gray Scale Of Blue	Blue(0) / Dark	0	0	0	0	0	0	0	0	0	0	0	0	0	0	0	0	0	0	0	0	0	0	0	0
	Blue(1)	0	0	0	0	0	0	0	0	0	0	0	0	0	0	0	0	0	0	0	0	0	0	0	1
	Blue(2)	0	0	0	0	0	0	0	0	0	0	0	0	0	0	0	0	0	0	0	0	0	0	1	0
	⋮	⋮	⋮	⋮	⋮	⋮	⋮	⋮	⋮	⋮	⋮	⋮	⋮	⋮	⋮	⋮	⋮	⋮	⋮	⋮	⋮	⋮	⋮	⋮	⋮
	⋮	⋮	⋮	⋮	⋮	⋮	⋮	⋮	⋮	⋮	⋮	⋮	⋮	⋮	⋮	⋮	⋮	⋮	⋮	⋮	⋮	⋮	⋮	⋮	⋮
	⋮	⋮	⋮	⋮	⋮	⋮	⋮	⋮	⋮	⋮	⋮	⋮	⋮	⋮	⋮	⋮	⋮	⋮	⋮	⋮	⋮	⋮	⋮	⋮	⋮
	Blue(253)	0	0	0	0	0	0	0	0	0	0	0	0	0	0	0	1	1	1	1	1	1	1	0	1
	Blue(254)	0	0	0	0	0	0	0	0	0	0	0	0	0	0	0	1	1	1	1	1	1	1	1	0
Blue(255)	0	0	0	0	0	0	0	0	0	0	0	0	0	0	0	1	1	1	1	1	1	1	1	1	

Note (1) 0: Low Level Voltage, 1: High Level Voltage

6. INTERFACE TIMING

6.1 INPUT SIGNAL TIMING SPECIFICATIONS

The input signal timing specifications are shown as the following table and timing diagram.

Signal	Item	Symbol	Min.	Typ.	Max.	Unit	Note
LVDS Clock	Frequency	Fc	-	44.5	56	MHz	-
	Period	Tc	17.9	22.5	-	ns	-
	High Time	Tch	-	4/7	-	Tc	-
	Low Time	Tcl	-	3/7	-	Tc	-
LVDS Data	Setup Time	Tlvs	600	-	-	ps	-
	Hold Time	Tlvh	600	-	-	ps	-
Vertical Active Display Term	Frame Rate	Fr	56	60	75	Hz	Tv=Tvd+Tvb
	Total	Tv	905	926	1050	Th	-
	Display	Tvd	900	900	900	Th	-
	Blank	Tvb	Tv-Tvd	26	Tv-Tvd	Th	-
Horizontal Active Display Term	Total	Th	750	800	960	Tc	Th=Thd+Thb
	Display	Thd	720	720	720	Tc	-
	Blank	Thb	Th-Thd	80	Th-Thd	Tc	-

Note: Because this module is operated by DE only mode, Hsync and Vsync input signals should be set to low logic level or ground. Otherwise, this module would operate abnormally.

INPUT SIGNAL TIMING DIAGRAM

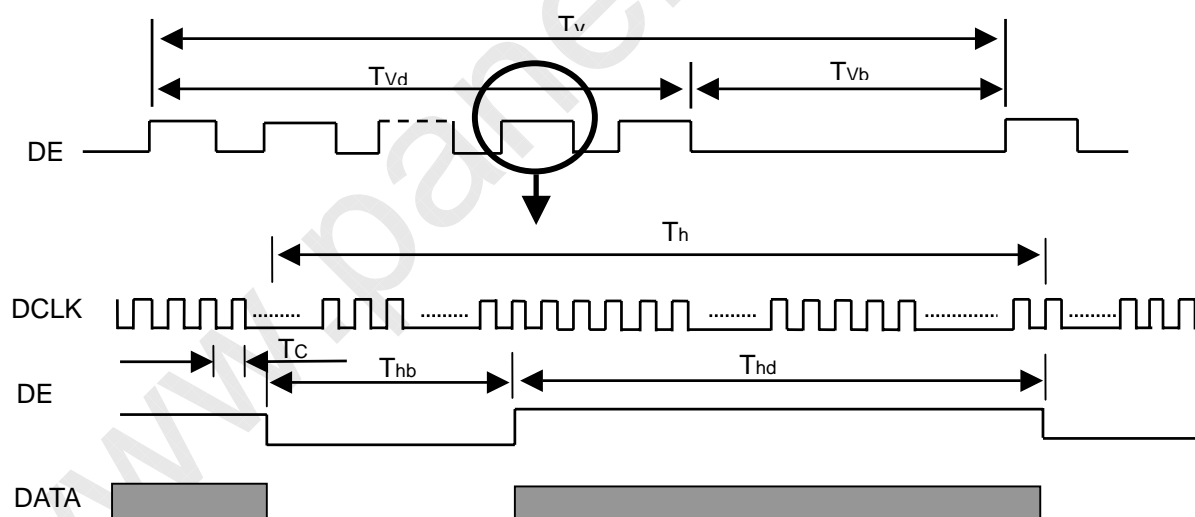

6.2 POWER ON/OFF SEQUENCE

To prevent a latch-up or DC operation of LCD module, the power on/off sequence should be as the diagram below.

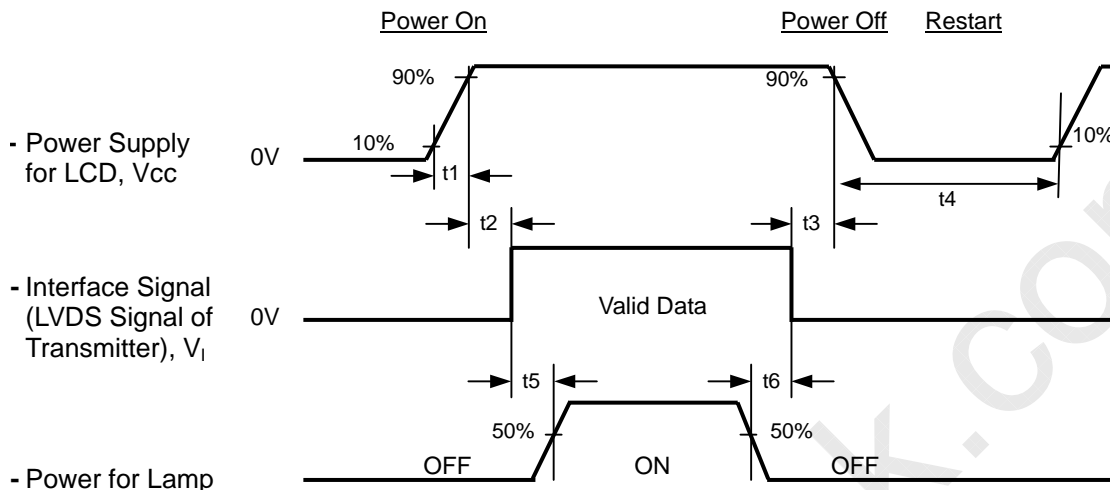

Timing Specifications:

$0.5 < t_1$	10 msec
$0 < t_2$	50 msec
$0 < t_3$	50 msec
t_4	500 msec
t_5	450 msec
t_6	90 msec

Note.

- (1) The supply voltage of the external system for the module input should be the same as the definition of V_{cc}.
- (2) Apply the lamp voltage within the LCD operation range. When the backlight turns on before the LCD operation of the LCD turns off, the display may momentarily become abnormal screen.
- (3) In case of V_{CC} = off level, please keep the level of input signals on the low or keep a high impedance.
- (4) T₄ should be measured after the module has been fully discharged between power off and on period.
- (5) Interface signal shall not be kept at high impedance when the power is on.

7. OPTICAL CHARACTERISTICS

7.1 TEST CONDITIONS

Item	Symbol	Value	Unit
Ambient Temperature	Ta	25±2	°C
Ambient Humidity	Ha	50±10	%RH
Supply Voltage	V _{CC}	5.0	V
Input Signal	According to typical value in "3. ELECTRICAL CHARACTERISTICS"		
Inverter Current	I _L	7.0	mA
Inverter Driving Frequency	F _L	61	KHz

7.2 OPTICAL SPECIFICATIONS

The relative measurement methods of optical characteristics are shown as below. The following items should be measured under the test conditions described in 7.1 and stable environment shown in Note (6).

Item		Symbol	Condition	Min.	Typ.	Max.	Unit	Note					
Color Chromaticity	Red	Rcx	$\theta_x=0^\circ, \theta_y=0^\circ$ CS-1000T Standard light source "C"	Typ - 0.03	0.649	Typ + 0.03	-	(0),(6)					
		Rcy			0.332		-						
	Green	Gcx			0.274		-						
		Gcy			0.589		-						
	Blue	Bcx			0.148		-						
		Bcy			0.101		-						
	White	Wcx			0.320		-						
		Wcy			0.356		-						
	Center Transmittance				T%		$\theta_x=0^\circ, \theta_y=0^\circ$		5.4	6.0	-	%	(1), (8)
	Contrast Ratio				CR		CS-1000T, CMO BLU		500	850	-	-	(1), (3)
Response Time		T _R	$\theta_x=0^\circ, \theta_y=0^\circ$	-	1.5	6.5	ms	(4)					
		T _F		-	3.5	8.5	ms						
Transmittance uniformity		$\delta T\%$	$\theta_x=0^\circ, \theta_y=0^\circ$ CA-210	-	1.25	1.4	-	(1), (7)					
Viewing Angle	Horizontal	θ_{x+}	CR≥10 CA-210	75	85	-	Deg.	(1), (2) (6)					
		θ_{x-}		75	85	-							
	Vertical	θ_{y+}		70	80	-							
		θ_{y-}		70	80	-							

7.3 Flicker Adjustment

(1) Adjustment Pattern: 2H1V checker pattern as follows.

R	G	B	R	G	B	R	G	B	R	G	B	R	G	B	R	G	B	R	G	B	R	G	B
R	G	B	R	G	B	R	G	B	R	G	B	R	G	B	R	G	B	R	G	B	R	G	B
R	G	B	R	G	B	R	G	B	R	G	B	R	G	B	R	G	B	R	G	B	R	G	B
R	G	B	R	G	B	R	G	B	R	G	B	R	G	B	R	G	B	R	G	B	R	G	B
R	G	B	R	G	B	R	G	B	R	G	B	R	G	B	R	G	B	R	G	B	R	G	B
R	G	B	R	G	B	R	G	B	R	G	B	R	G	B	R	G	B	R	G	B	R	G	B
R	G	B	R	G	B	R	G	B	R	G	B	R	G	B	R	G	B	R	G	B	R	G	B
R	G	B	R	G	B	R	G	B	R	G	B	R	G	B	R	G	B	R	G	B	R	G	B
R	G	B	R	G	B	R	G	B	R	G	B	R	G	B	R	G	B	R	G	B	R	G	B



(2) Adjustment Method:

Flicker should be adjusted by turning the volume for flicker adjustment by the ceramic driver. It is adjusted to the point with least flickering of the whole screen. After making it surely overrun at once, it should be adjusted to the optimum point.

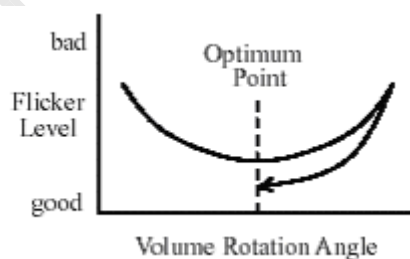

Note (0) Light source is the standard light source "C" which is defined by CIE and driving voltages are based on suitable gamma voltages. The calculating method is as following :

1. Measure Module's and BLU's spectrums. White is without signal input and R, G, B are with signal input. BLU(for M190A1-L02) is supplied by CMO.
2. Calculate cell's spectrum.
3. Calculate cell's chromaticity by using the spectrum of standard light source "C"

Note (1) Light source is the BLU which is supplied by CMO and driving voltages are based on suitable gamma voltages.

Note (2) Definition of Viewing Angle (θ_x , θ_y):

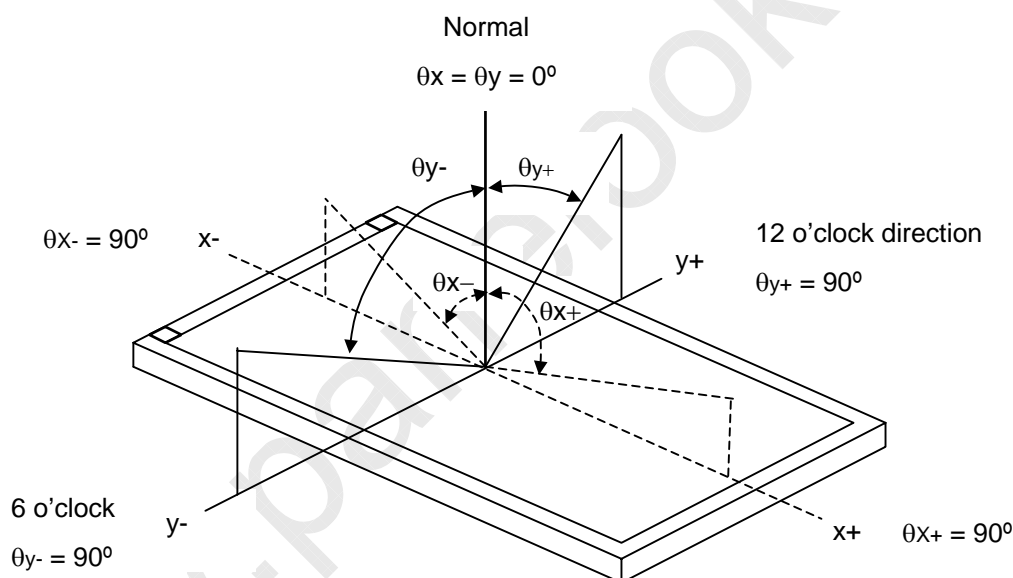

Note (3) Definition of Contrast Ratio (CR):

The contrast ratio can be calculated by the following expression.

$$\text{Contrast Ratio (CR)} = L_{255} / L_0$$

L₂₅₅: Luminance of gray level 255

L₀: Luminance of gray level 0

$$\text{CR} = \text{CR} (1)$$

CR (X) is corresponding to the Contrast Ratio of the point X at Figure in Note (7).

Note (4) Definition of Response Time (T_R , T_F):

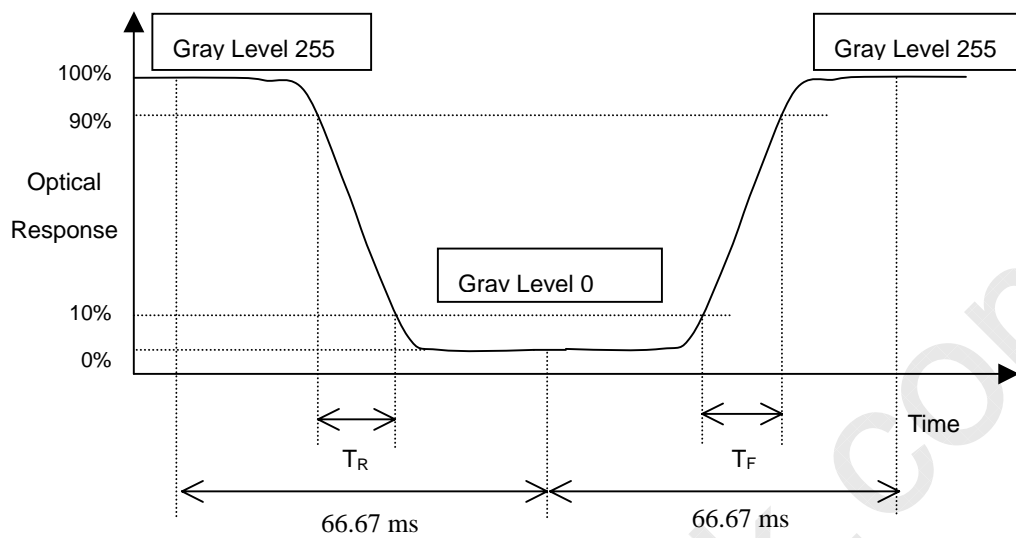

Note (5) Definition of Luminance of White (L_C):

Measure the luminance of gray level 255 at center point

$$L_C = L(1)$$

$L(x)$ is corresponding to the luminance of the point X at Figure in Note (7).

Note (6) Measurement Setup:

The LCD module should be stabilized at given temperature for 20 minutes to avoid abrupt temperature change during measuring. In order to stabilize the luminance, the measurement should be executed after lighting Backlight for 20 minutes in a windless room.

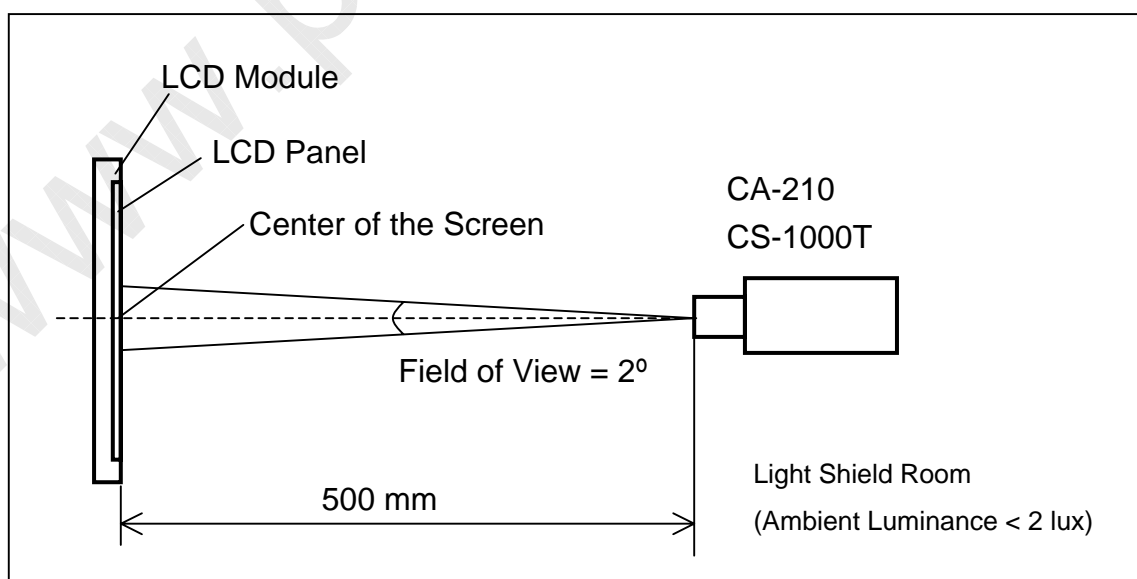

Note (7) Definition of Transmittance Variation ($\delta T\%$):

Measure the transmittance at 13 points

$$\delta T\% = \frac{\text{Maximum [L (1), L (2), \dots, L (12), L (13)]}}{\text{Minimum [L (1), L (2), \dots, L (12), L (13)]}}$$

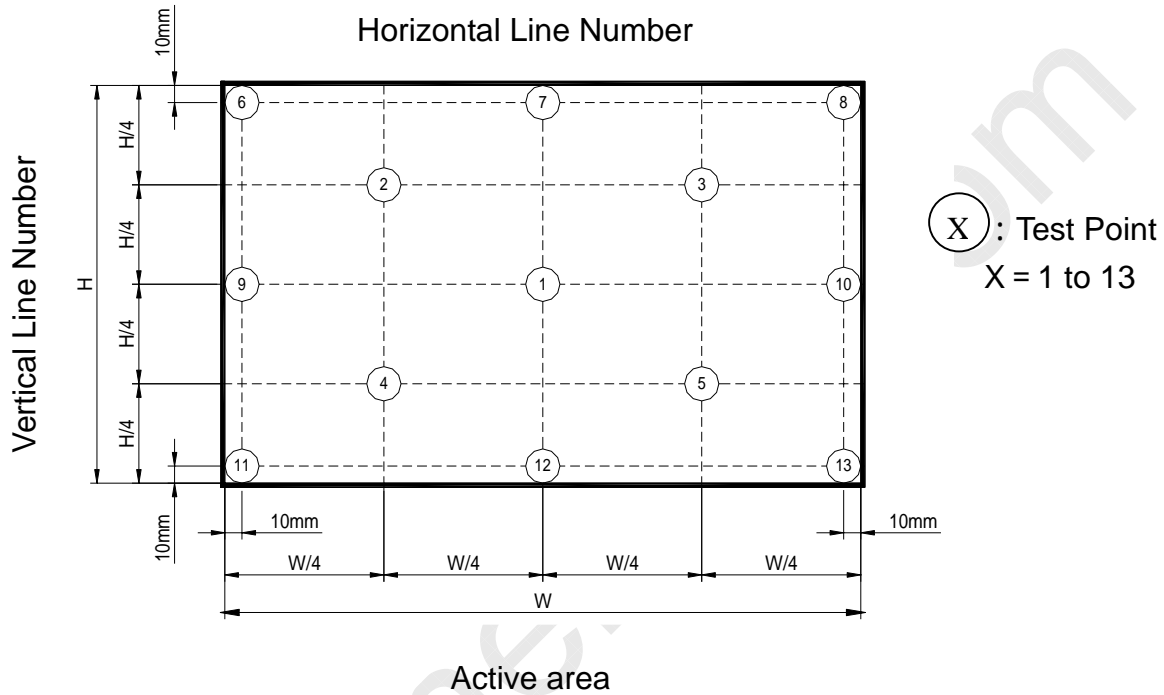

Note (8) Definition of Transmittance (T%):

Module is without signal input.

$$\text{Transmittance} = \frac{\text{Luminance of LCD module}}{\text{Luminance of backlight}} * 100\%$$

8. PACKAGING

8.1 PACKING SPECIFICATIONS

- (1) 15 open cells / 1 Box
- (2) Box dimensions: 615 (L) X 515 (W) X 385 (H) mm
- (3) Weight: approximately 14.6Kg (15 open cells per box)

8.2 PACKING METHOD

- (1) Carton Packing should have no failure in the following reliability test items

Test Item	Test Conditions	Note
Packing Vibration	ISTA STANDARD Random, Frequency Range: 1 – 200 Hz Top & Bottom: 30 minutes (+Z), 10 min (-Z), Right & Left: 10 minutes (X) Back & Forth 10 minutes (Y)	Non Operation

- (2) Packing method.

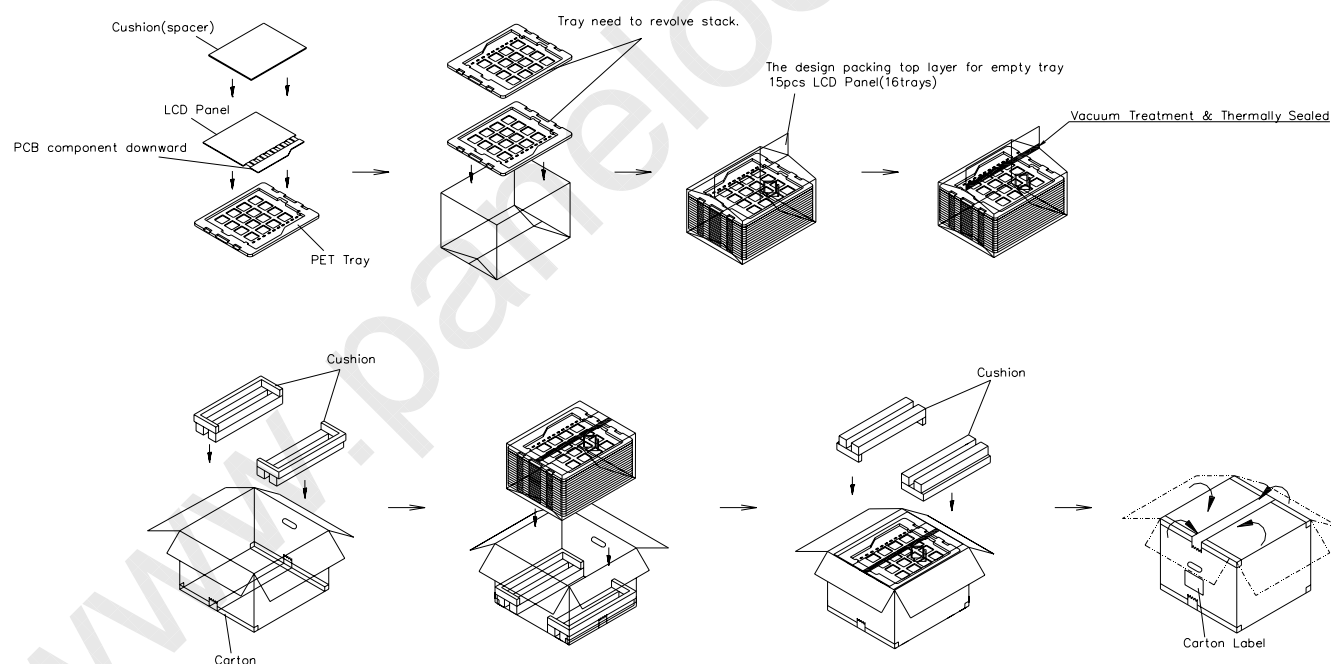

- (1) 15 LCD Cells+PCB/1 box
- (2) Carton dimensions : 615(L)x515(W)x385(H)mm
- (3) Weight : approximately 14.6kg(15 Cells per Carton).



Approval

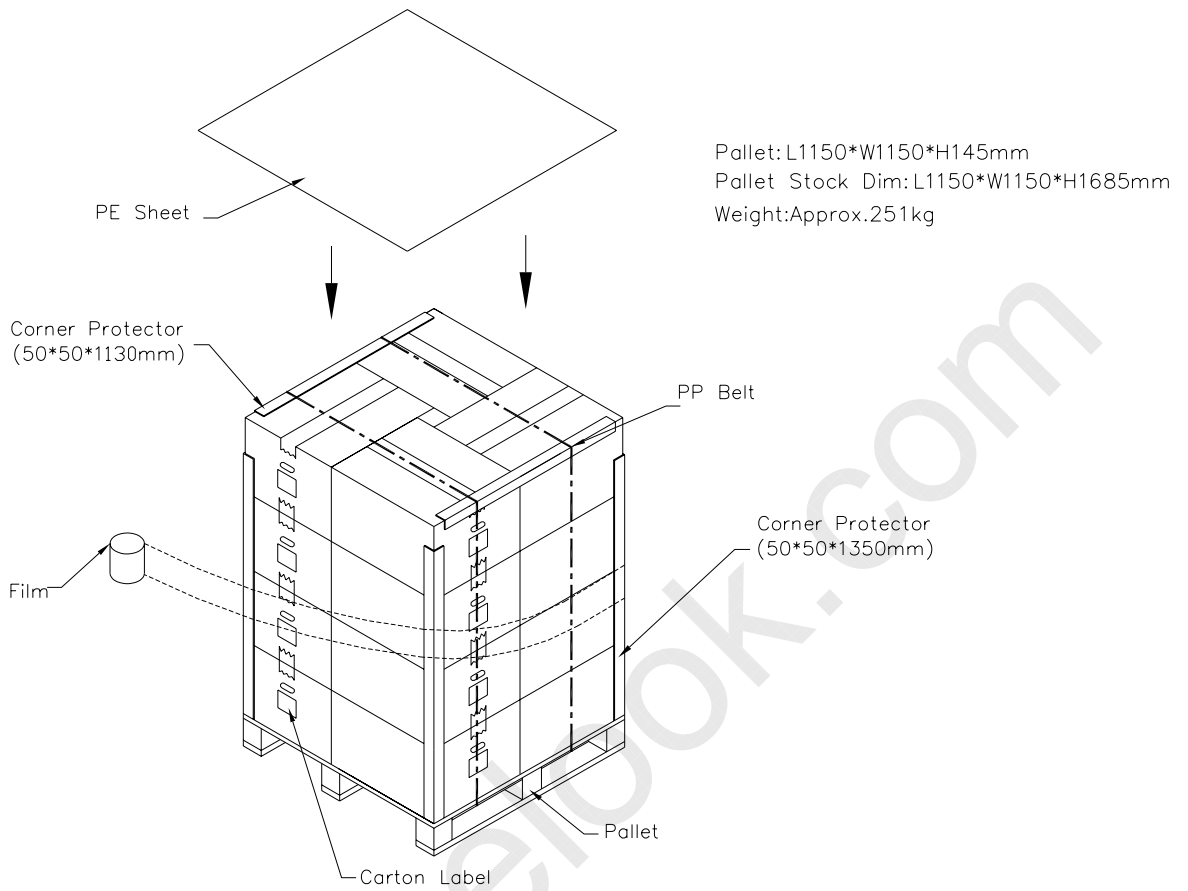

www.panelook.com

9. DEFINITION OF LABELS

9.1 CMO OPEN CELL LABEL

The barcode nameplate is pasted on each OPEN CELL as illustration for CMO internal control.



Barcode definition:

Serial ID: CM-19A12-X-X-X-XX-L-XX-L-YMD-NNNN

Code	Meaning	Description
CM	Supplier code	CMO=CM
19A12	Model number	M190A1-P02=19A12
X	Revision code	Non ZBD: 0~9, ZBD: A~Z
X	Source driver IC code	Century=1, CLL=2, Demos=3, Epson=4, Fujitsu=5, Himax=6, Hitachi=7, Hynix=8, LDI=9, Matsushita=A, NEC=B, Novatec=C, OKI=D, Philips=E, Renasas=F, Samsung=G, Sanyo=H, Sharp=I, TI=J, Topro=K, Toshiba=L, Windbond=M
X	Gate driver IC code	
XX	Cell location	Tainan, Taiwan=TN
L	Cell line #	0~12=1~C
XX	Module location	Tainan, Taiwan=TN
L	Module line #	0~12=1~C
YMD	Year, month, day	Year: 2001=1, 2002=2, 2003=3, 2004=4... Month: 1~12=1, 2, 3, ~, 9, A, B, C Day: 1~31= 1, 2, 3, ~, 9, A, B, C, ~, T, U, V
NNNN	Serial number	Manufacturing sequence of product

9.2 CARTON LABEL

The barcode nameplate is pasted on each box as illustration, and its definitions are as following explanation

PO.NO.	_____
Part ID.	_____
Model Name	<u> M190A1-P02 </u>
Carton ID.	 Quantities <u> 15 </u>
	QEA11015AJ3001

- (a) Model Name: M190A1 –P02
- (b) Carton ID: CMO internal control
- (c) Quantities: 15 pcs

10. PRECAUTIONS

10.1 ASSEMBLY AND HANDLING PRECAUTIONS

- (1) Do not apply rough force such as bending or twisting to the product during assembly.
- (2) To assemble backlight or install module into user's system can be only in clean working areas. The dust and oil may cause electrical short or worsen the polarizer.
- (3) It is not permitted to have pressure or impulse on the module because the LCD panel will be damaged.
- (4) Always follow the correct power sequence when the product is connecting and operating. This can prevent damage to the CMOS LSI chips during latch-up.
- (5) Do not pull the I/F connector in or out while the module is operating.
- (6) Use a soft dry cloth without chemicals for cleaning, because the surface of polarizer is very soft and easily scratched.
- (7) It is dangerous that moisture come into or contacted the product, because moisture may damage the product when it is operating.
- (8) High temperature or humidity may reduce the performance of module. Please store this product within the specified storage conditions.
- (9) When ambient temperature is lower than 10°C may reduce the display quality. For example, the response time will become slowly.

10.2 SAFETY PRECAUTIONS

- (1) If the liquid crystal material leaks from the panel, it should be kept away from the eyes or mouth. In case of contact with hands, skin or clothes, it has to be washed away thoroughly with soap.
- (2) After the product's end of life, it is not harmful in case of normal operation and storage.

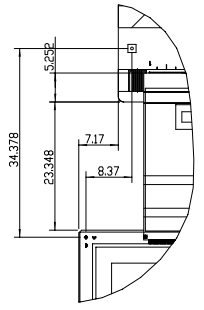
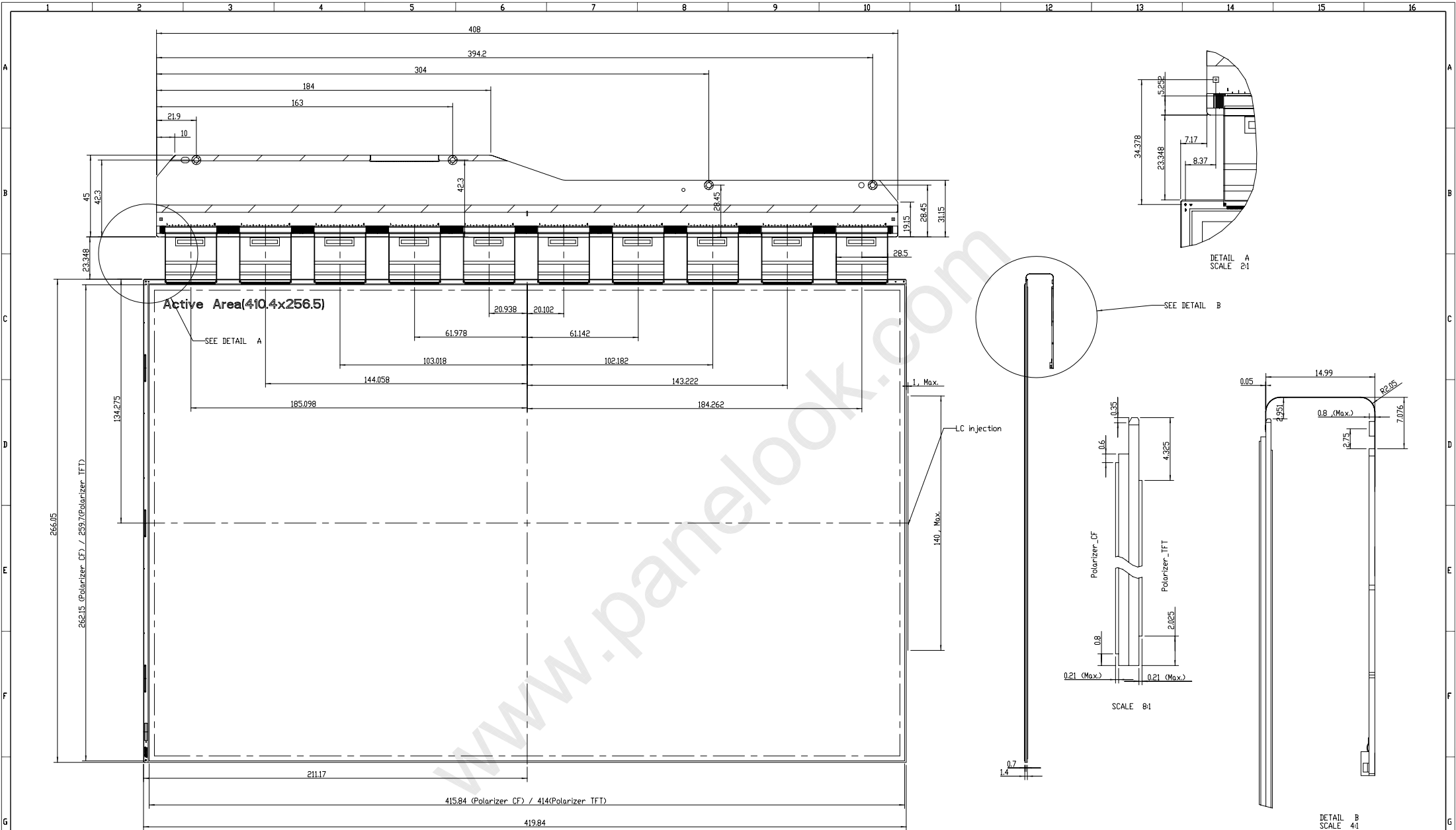

DETAIL A
SCALE 2:1

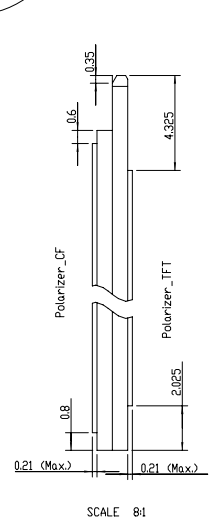
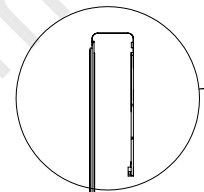

SCALE 8:1

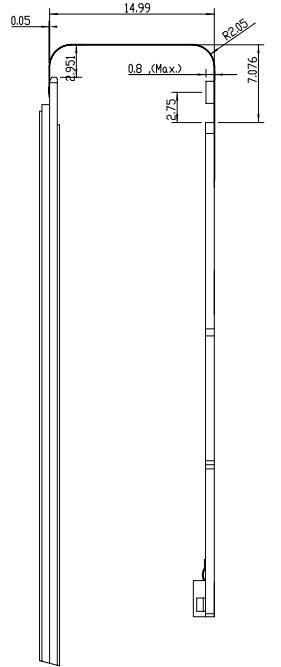

DETAIL B
SCALE 4:1

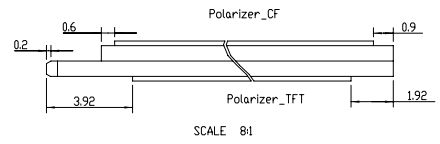

SCALE 8:1

Mark	Description	Date	Changed_By	Approved_By	ECN No.	Remark

TITLE	PANEL_CF_PCB_M190A1-P01/M190A1-P02	PD REV. 11
Approved	JEMMY CHANG	Drawing No. M190941031
Checked	TAURUS HESIEH	Part No. TBD
Drawer	TOBIAS WANG	Material TBD
Designer	TIGER CHANG	Date 22-Dec-2004 Scale 1:1 Unit mm
		ALL RIGHTS RESERVED, COPYING FORBIDDEN.