

TFT LCD Approval Specification

Model No : M190A1-PS1

Customer : _____

Approved by : _____

Note :

記錄	工作	審核	角色	投票
2007-10-16 12:58:28 CST	PMMD Director	cs_lee(李志聖 /56510/44926)	Director	Accept

- CONTENTS -

REVISION HISTORY	3
1. GENERAL DESCRIPTION	4
1.1 OVERVIEW	
1.2 FEATURES	
1.3 APPLICATION	
1.4 GENERAL SPECIFICATIONS	
1.5 MECHANICAL SPECIFICATIONS	
2. ABSOLUTE MAXIMUM RATINGS	5
2.1 ABSOLUTE RATINGS OF ENVIRONMENT (BASE ON CMO MODULE S190A2-M01)	
2.2 ABSOLUTE RATINGS OF ENVIRONMENT (OPEN CELL)	
2.3 ELECTRICAL ABSOLUTE RATINGS (OPEN CELL)	
3. ELECTRICAL CHARACTERISTICS	7
3.1 TFT LCD MODULE	
4. BLOCK DIAGRAM	8
4.1 TFT LCD MODULE	
5. INPUT TERMINAL PIN ASSIGNMENT	9
5.1 TFT LCD MODULE	
5.2 TIMING DIAGRAM OF LVDS INPUT SIGNAL	
5.3 COLOR DATA INPUT ASSIGNMENT	
6. INTERFACE TIMING	12
6.1 INPUT SIGNAL TIMING SPECIFICATIONS	
6.2 POWER ON/OFF SEQUENCE	
7. DRIVER DC CHARACTERISTICS	14
7.1 RSDS CHARACTERISTICS	
7.2 ELECTRICAL CHARACTERISTICS (VSSD=VSSA=0V)	
8. DRIVER AC CHARACTERISTICS	16
9. VERTICAL TIMING	17
10. OPTICAL CHARACTERISTICS	18
10.1 TEST CONDITIONS	
10.2 OPTICAL SPECIFICATIONS	
10.3 FLICKER ADJUSTMENT	
11. PACKAGING	23
11.1 PACKING SPECIFICATIONS	
11.2 PACKING METHOD	
12. DEFINITION OF LABELS	25
12.1 OPEN CELL LABEL	
12.2 CARTON LABEL	
13. PRECAUTIONS	27
13.1 ASSEMBLY AND HANDLING PRECAUTIONS	
13.2 SAFETY PRECAUTIONS	
14. PANEL DRAWING	28

REVISION HISTORY

Version	Date	Section	Description
Ver. 2.0	Feb., 01 '07	-	M190A1- PS1 Approval Specifications was first issued °
Ver. 2.1	Apr., 12 '07	10.3	Modify (1)Adjustment Pattern (2)Adjustment Method for RSDS interface
		12.1	Modify CMO OPEN CELL LABEL.
		12.2	Modify CMO CARTON LABEL.
Ver. 2.2	Sep, 17 '07	11.2	Modify Packing Method

1. GENERAL DESCRIPTION

1.1 OVERVIEW

The M190A1-PS1 is a 19-inch wide TFT LCD cell with driver ICs and a RSDS circuit board. The product supports 1440 x 900 WXGA+ mode. The backlight unit is not built in.

1.2 FEATURES

- Super wide viewing angle
- Super High contrast ratio
- Super Fast response time
- High color saturation
- WXGA+ (1440 x 900 pixels) resolution
- RSDS (Reduced Swing Differential Signaling) interface
- RoHS Compliance

1.3 APPLICATION

- TFT LCD Monitor
- TFT LCD TV

1.4 GENERAL SPECIFICATIONS

Item	Specification	Unit	Note
Diagonal Size	19.05	inch	
Active Area	410.4 (H) x 256.5 (V)	mm	(1)
Driver Element	a-si TFT active matrix	-	-
Pixel Number	1440 x R.G.B. x 900	pixel	-
Pixel Pitch	0.285 (H) x 0.285 (V)	mm	-
Pixel Arrangement	RGB vertical stripe	-	-
Transmissive Mode	Normally white	-	-
Surface Treatment	Hard coating (3H), Anti-glare (Haze 25%)	-	-

1.5 MECHANICAL SPECIFICATIONS

Item	Min.	Typ.	Max.	Unit	Note
Weight	-	490	-	g	-
I/F connector mounting position	The mounting inclination of the connector makes the screen center within $\pm 0.5\text{mm}$ as the horizontal.				(2)

Note (1) Please refer to the attached drawings for more information of front and back outline dimensions.

(2) Connector mounting position

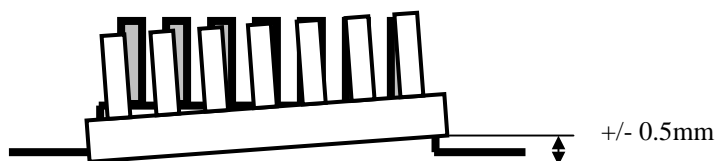

2. ABSOLUTE MAXIMUM RATINGS

2.1 ABSOLUTE RATINGS OF ENVIRONMENT (BASE ON CMO MODULE S190A2-M01)

Item	Symbol	Value		Unit	Note
		Min.	Max.		
Storage Temperature	T _{ST}	-20	+60	°C	(1)
Operating Ambient Temperature	T _{OP}	0	+50	°C	(1), (2)

Note (1) Temperature and relative humidity range is shown in the figure below.

- (a) 90 %RH Max. ($T_a \leq 40$ °C).
- (b) Wet-bulb temperature should be 39 °C Max. ($T_a > 40$ °C).
- (c) No condensation.

Note (2) The temperature of panel display surface area should be 0 °C Min. and 60 °C Max.

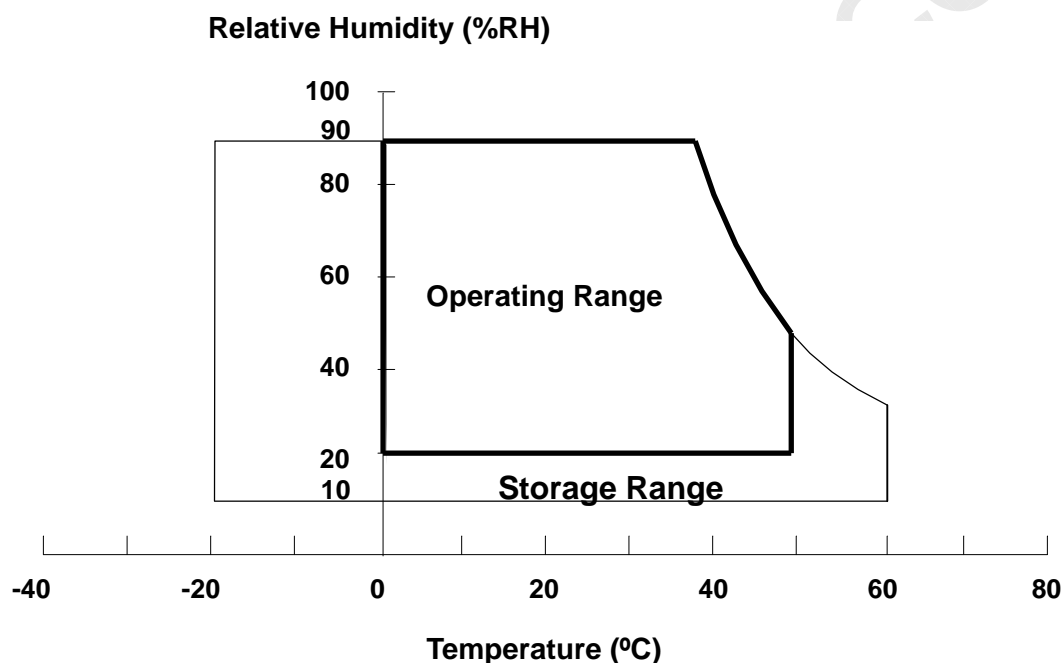

2.2 ABSOLUTE RATINGS OF ENVIRONMENT (OPEN CELL)

High temperature or humidity may reduce the performance of panel. Please store LCD panel within the specified storage conditions.

Storage Condition: With packing.

Storage temperature range: 25±5 °C.

Storage humidity range: 50±10%RH.

Shelf life: 30days

2.3 ELECTRICAL ABSOLUTE RATINGS (OPEN CELL)

Item	Symbol	Value		Unit	Note
		Min.	Max.		
Power Supply Voltage for LCD	V _{in}	13.2	14.4	V	
Logic Input Voltage	V _{5A}	-0.3	6.0	V	(1)
Logic Input Voltage	V _{DD}	-0.3	4.3	V	

Note (1) Permanent damage might occur if the module is operated at conditions exceeding the maximum values.

3. ELECTRICAL CHARACTERISTICS (OPEN CELL)

3.1 TFT LCD OPEN CELL

 $T_a = 25 \pm 2 \text{ }^\circ\text{C}$

Parameter	SYMBOL	Value			UNIT	Note	
		MIN	TYP	MAX			
Power Supply Voltage for LCD	Vin	13.2	13.8	14.4	V	-	
Power Supply Current for LCD	Iin	-	300	-	mA	-	
Logic Input Voltage	V5A	4.75	5	5.25	V	Reserve	
Logic Input Current	I5A	-	25	-	mA	Reserve	
Driver Logic Input Voltage	VDD	-	3.3	-	V	-	
Driver Logic Input Current	IDD	-	55	-	mA	-	
Differential Impedence	Zm	-	100	-	Ω	-	
LCD Inrush Current	Irush	-	3	-	A	-	
PANEL On	High	PANEL_ON	2.5	3.3	-	V	-
	Low		-	-	0.6	V	-
DCDC On	High	DCDC_ON	2.5	3.3	-	V	-
	Low		-	-	0.6	V	-
VCOM PWM	High	VCOM_PWM	2.5	-	-	V	-
	Low		-	-	0.6	V	-
VCOM PWM Frequency	VCOM_PWM	-	27	-	KHz	Adjustable Duty Cycle	

Note (1) The module is recommended to operate within specification ranges listed above for normal function.

4. BLOCK DIAGRAM

4.1 TFT LCD MODULE

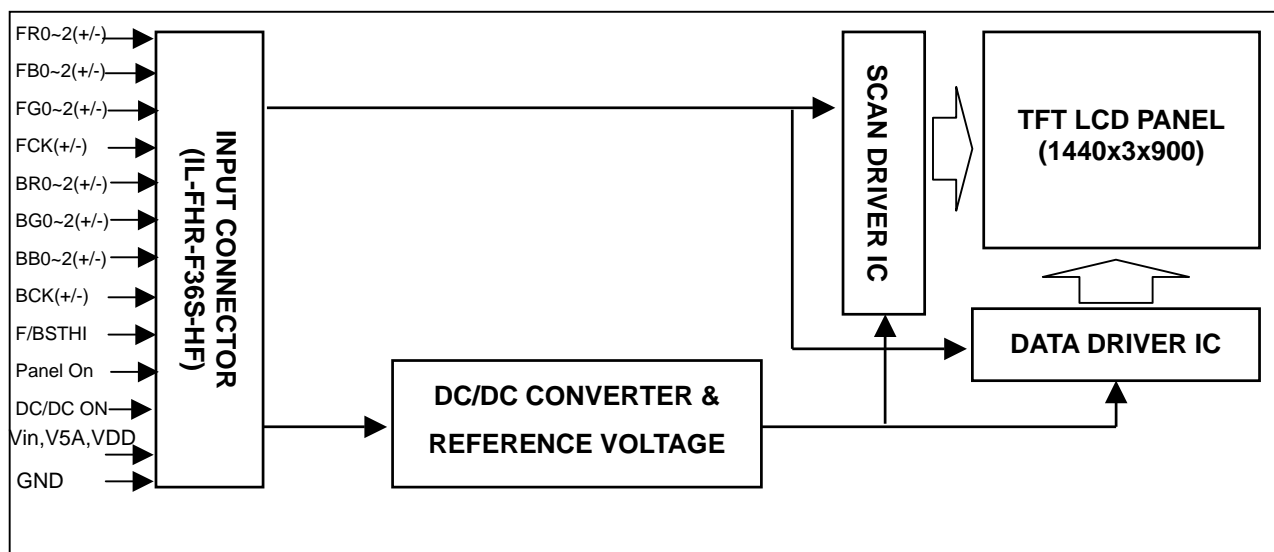

5. INPUT TERMINAL PIN ASSIGNMENT

5.1 TFT LCD MODULE

(1)CN1 (Panel Interface)

Pin	Name	Description
1	Vin	Driver Power Input Voltage
2	Vin	Driver Power Input Voltage
3	V5A	Logic Input Voltage +5V
4	PANEL_ON	This pin is used to control the driver Logic Input Voltage VDD. When PANEL_ON input is "H", VDD will be to driver.
5	DCDC_ON	This pin is used to control the PWM IC. When DCDC_ON input is "H", it enable PWM IC.
6	VCM_PWM	This pin is used to generate common voltage for panel. Adjust pulse width could be changed common voltage.
7	GVOFF	Gate driver high voltage switch timing control.
8	NC	No connect
9	GND	Ground
10	BSTHI	Data driver start pulse input(Back)
11	GND	Ground
12	BR0N	Negative RSDS differential data input. Channel R0(Back)
13	BR0P	Positive RSDS differential data input. Channel R0(Back)
14	BR1N	Negative RSDS differential data input. Channel R1(Back)
15	BR1P	Positive RSDS differential data input. Channel R1(Back)
16	BR2N	Negative RSDS differential data input. Channel R2(Back)
17	BR2P	Positive RSDS differential data input. Channel R2(Back)
18	GND	Ground
19	BCKN	Negative RSDS differential clock input. (Back)
20	BCKP	Positive RSDS differential clock input. (Back)
21	GND	Ground
22	BG0N	Negative RSDS differential data input. Channel G0(Back)
23	BG0P	Positive RSDS differential data input. Channel G0(Back)
24	BG1N	Negative RSDS differential data input. Channel G1(Back)
25	BG1P	Positive RSDS differential data input. Channel G1(Back)
26	BG2N	Negative RSDS differential data input. Channel G2(Back)
27	BG2P	Positive RSDS differential data input. Channel G2(Back)
28	GND	Ground
29	BB0N	Negative RSDS differential data input. Channel B0(Back)
30	BB0P	Positive RSDS differential data input. Channel B0(Back)
31	BB1N	Negative RSDS differential data input. Channel B1(Back)
32	BB1P	Positive RSDS differential data input. Channel B1(Back)
33	BB2N	Negative RSDS differential data input. Channel B2(Back)
34	BB2P	Positive RSDS differential data input. Channel B2(Back)
35	GND	Ground
36	GND	Ground

(2)CN2 (Panel Interface)

Pin	Name	Description
1	VDD	Driver Logic Input Voltage
2	VDD	Driver Logic Input Voltage
3	XAO	When /XAO input pin is low, all the Gate driver output pins are forced to VGH level. Note that this pin has higher priority than OE.
4	STV	Gate driver start pulse is read at the rising edge of CKV and a scan signal is output from the gate driver output pin.
5	CKV	Gate driver shift clock
6	OE	This pin is used to control the Gate driver output. When OE input is "H", gate driver output is fixed to VGL level regardless CKV.
7	GND	Ground
8	FR0N	Negative RSDS differential data input. Channel R0(Front)
9	FR0P	Positive RSDS differential data input. Channel R0(Front)
10	FR1N	Negative RSDS differential data input. Channel R1(Front)
11	FR1P	Positive RSDS differential data input. Channel R1(Front)
12	FR2N	Negative RSDS differential data input. Channel R2(Front)
13	FR2P	Positive RSDS differential data input. Channel R2(Front)
14	GND	Ground
15	POL	Data driver polarity inverting input
16	STB	The contents of the data driver register are transferred to the latch circuit at the rising edge of STB. Then the gray scale voltage is output from the device at the falling edge of STB.
17	GND	Ground
18	FCKN	Negative RSDS differential clock input. (Front)
19	FCKP	Positive RSDS differential clock input. (Front)
20	GND	Ground
21	FG0N	Negative RSDS differential data input. Channel G0(Front)
22	FG0P	Positive RSDS differential data input. Channel G0(Front)
23	FG1N	Negative RSDS differential data input. Channel G1(Front)
24	FG1P	Positive RSDS differential data input. Channel G1(Front)
25	FG2N	Negative RSDS differential data input. Channel G2(Front)
26	FG2P	Positive RSDS differential data input. Channel G2(Front)
27	GND	Ground
28	FB0N	Negative RSDS differential data input. Channel B0(Front)
29	FB0P	Positive RSDS differential data input. Channel B0(Front)
30	FB1N	Negative RSDS differential data input. Channel B1(Front)
31	FB1P	Positive RSDS differential data input. Channel B1(Front)
32	FB2N	Negative RSDS differential data input. Channel B2(Front)
33	FB2P	Positive RSDS differential data input. Channel B2(Front)
34	FSTHI	Data driver start pulse input(Front)
35	GND	Ground
36	GND	Ground

Note (1) Connector Part No.: IL-FHR-F36S-HF.



Approval

5.2 COLOR DATA INPUT ASSIGNMENT

The brightness of each primary color (red, green and blue) is based on the 6-bit gray scale data input for the color. The higher the binary input, the brighter the color. The table below provides the assignment of color versus data input.

Color		Data Signal																	
		Red						Green						Blue					
		R5	R4	R3	R2	R1	R0	G5	G4	G3	G2	G1	G0	B5	B4	B3	B2	B1	B0
Basic Colors	Black	0	0	0	0	0	0	0	0	0	0	0	0	0	0	0	0	0	0
	Red	1	1	1	1	1	1	0	0	0	0	0	0	0	0	0	0	0	0
	Green	0	0	0	0	0	0	1	1	1	1	1	1	0	0	0	0	0	0
	Blue	0	0	0	0	0	0	0	0	0	0	0	0	1	1	1	1	1	1
	Cyan	0	0	0	0	0	0	1	1	1	1	1	1	1	1	1	1	1	1
	Magenta	1	1	1	1	1	1	0	0	0	0	0	0	1	1	1	1	1	1
	Yellow	1	1	1	1	1	1	1	1	1	1	1	1	0	0	0	0	0	0
	White	1	1	1	1	1	1	1	1	1	1	1	1	1	1	1	1	1	1
Gray Scale Of Red	Red(0) / Dark	0	0	0	0	0	0	0	0	0	0	0	0	0	0	0	0	0	0
	Red(1)	0	0	0	0	0	1	0	0	0	0	0	0	0	0	0	0	0	0
	Red(2)	0	0	0	0	1	0	0	0	0	0	0	0	0	0	0	0	0	0
	:	:	:	:	:	:	:	:	:	:	:	:	:	:	:	:	:	:	:
	:	:	:	:	:	:	:	:	:	:	:	:	:	:	:	:	:	:	:
	Red(61)	1	1	1	1	0	1	0	0	0	0	0	0	0	0	0	0	0	0
	Red(62)	1	1	1	1	1	0	0	0	0	0	0	0	0	0	0	0	0	0
Red(63)	1	1	1	1	1	1	0	0	0	0	0	0	0	0	0	0	0	0	
Gray Scale Of Green	Green(0) / Dark	0	0	0	0	0	0	0	0	0	0	0	0	0	0	0	0	0	0
	Green(1)	0	0	0	0	0	0	0	0	0	0	0	1	0	0	0	0	0	0
	Green(2)	0	0	0	0	0	0	0	0	0	0	1	0	0	0	0	0	0	0
	:	:	:	:	:	:	:	:	:	:	:	:	:	:	:	:	:	:	:
	:	:	:	:	:	:	:	:	:	:	:	:	:	:	:	:	:	:	:
	Green(61)	0	0	0	0	0	0	1	1	1	1	0	1	0	0	0	0	0	0
	Green(62)	0	0	0	0	0	0	1	1	1	1	1	0	0	0	0	0	0	0
Green(63)	0	0	0	0	0	0	1	1	1	1	1	1	0	0	0	0	0	0	
Gray Scale Of Blue	Blue(0) / Dark	0	0	0	0	0	0	0	0	0	0	0	0	0	0	0	0	0	0
	Blue(1)	0	0	0	0	0	0	0	0	0	0	0	0	0	0	0	0	0	1
	Blue(2)	0	0	0	0	0	0	0	0	0	0	0	0	0	0	0	0	1	0
	:	:	:	:	:	:	:	:	:	:	:	:	:	:	:	:	:	:	:
	:	:	:	:	:	:	:	:	:	:	:	:	:	:	:	:	:	:	:
	Blue(61)	0	0	0	0	0	0	0	0	0	0	0	0	1	1	1	1	0	1
	Blue(62)	0	0	0	0	0	0	0	0	0	0	0	0	1	1	1	1	1	0
Blue(63)	0	0	0	0	0	0	0	0	0	0	0	0	1	1	1	1	1	1	

Note (1) 0: Low Level Voltage, 1: High Level Voltage

6. INTERFACE TIMING

6.1 INPUT SIGNAL TIMING SPECIFICATIONS

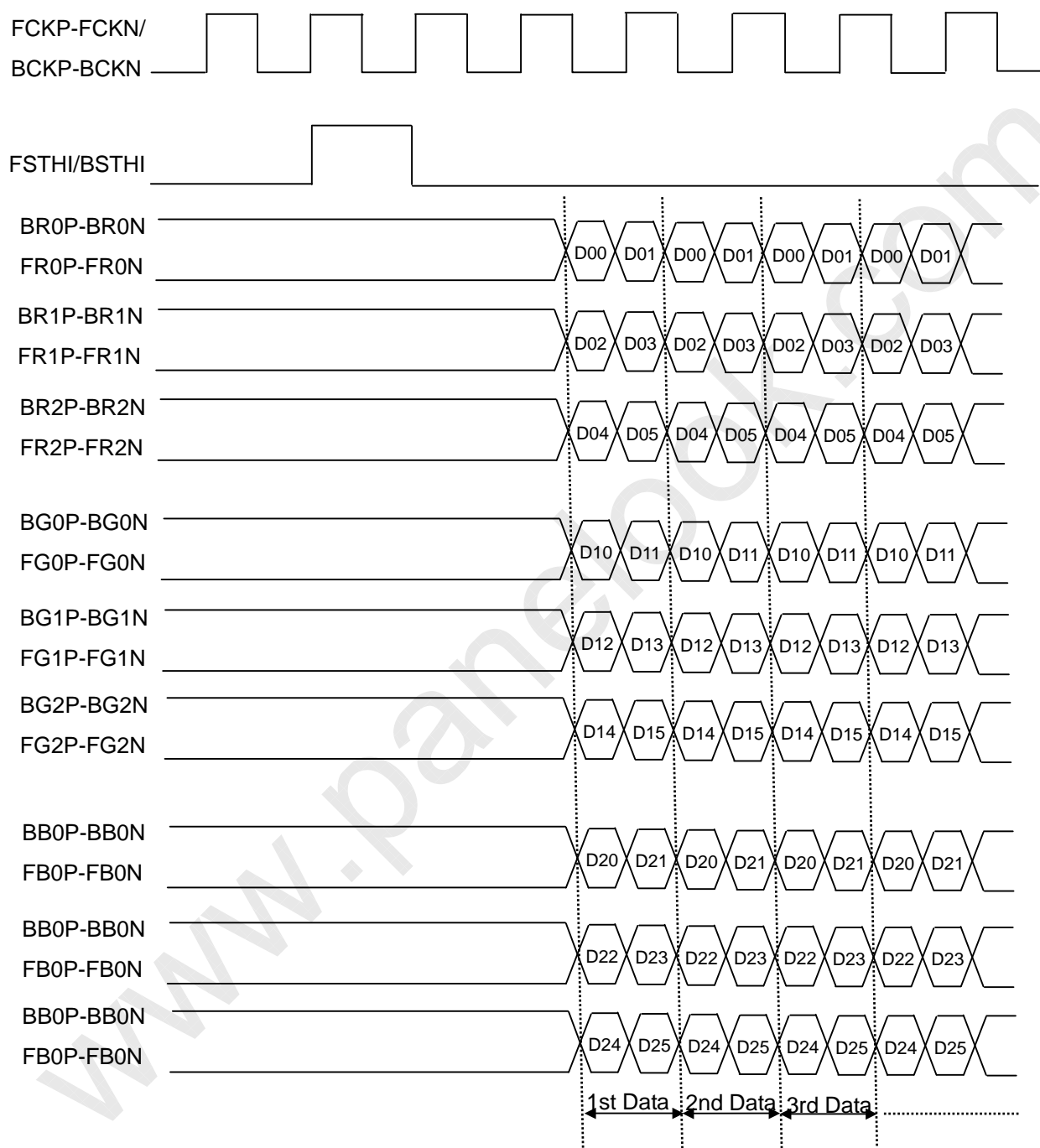

6.2 POWER ON/OFF SEQUENCE

To prevent a latch-up or DC operation of LCD module, the power on/off sequence should be as the diagram below.

Parameter	Symbol	Condition	Spec			Unit
			Min.	Typ.	Max.	
Panel On to DC/DC On	t_1	-	10	-	-	mS
DC/DC On to RSDS Data	t_2	-	-	50	-	
RSDS Data to BL_On	t_3	-	-	200	-	
RSDS Data Off to Panel Off	t_4	-	-	100	-	

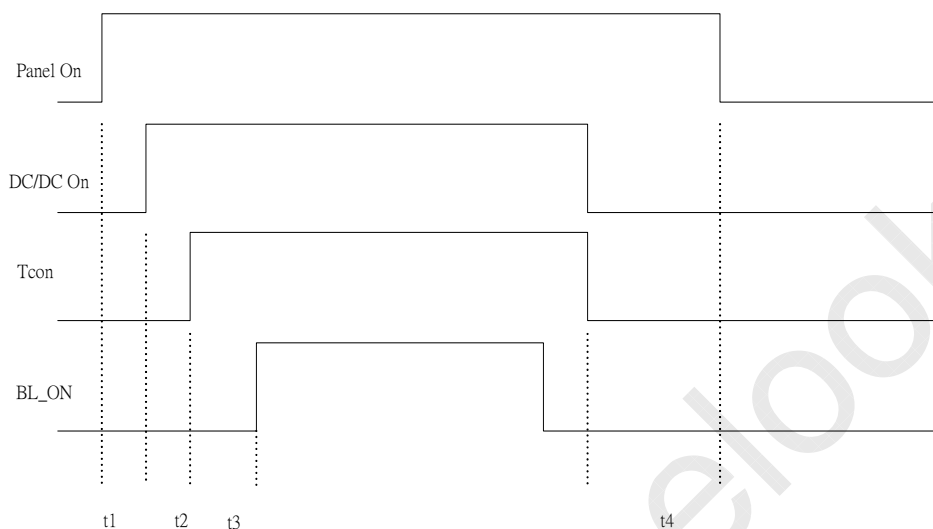

7. Driver DC CHARACTERISTICS

7.1 RSDS CHARACTERISTICS

(VDD = 2.3 to 3.6 V, VDDA = 8.0 to 13.5 V, VSSD = VSSA = 0V)

Parameter	Symbol	Condition	Min.	Typ.	Max.	Unit
RSDS high input voltage	$V_{DIFFRSDS}$	$V_{CMRSDS} = +1.2\text{ V}^{(1)}$	100	200	-	mV
RSDS low input voltage	$V_{DIFFRSDS}$	$V_{CMRSDS} = +1.2\text{ V}^{(1)}$	-	-200	-100	
RSDS common mode input voltage range	V_{CMRSDS}	$V_{DIFFRSDS} = +200\text{ mV}^{(2)}$	$V_{SSD} + 0.1$	-	$V_{DDD} - 1.2$	V
RSDS input leakage current	IDL	DxxP, DxxN, CLKP, CLKN	-10	-	10	μA

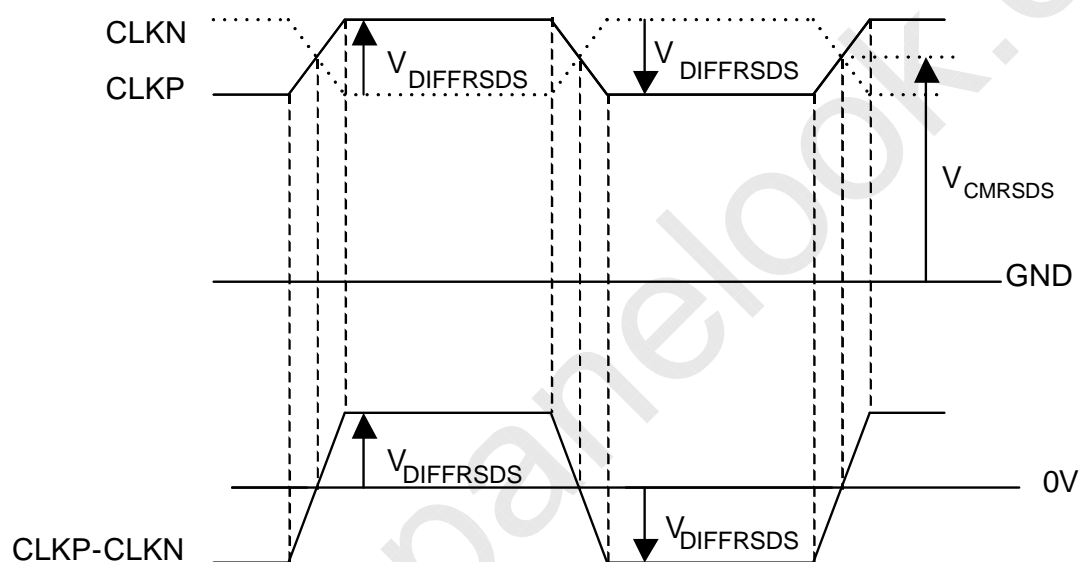
Note: (1) $V_{CMRSDS} = (V_{CLKP} + V_{CLKN}) / 2$ or $V_{CMRSDS} = (V_{DxxP} + V_{DxxN}) / 2$ (2) $V_{DIFFRSDS} = V_{CLKP} - V_{CLKN}$ or $V_{DIFFRSDS} = V_{DxxP} - V_{DxxN}$ 

7.2 ELECTRICAL CHARACTERISTICS (VSSD=VSSA=0V)

Parameter	Symbol	Condition	Spec			Unit
			Min.	Typ.	Max.	
RSDS input "Low" Voltage	$V_{DIFFRSDS}$	DX[2:0]P,DX[2:0]N, CLKP,CLKN	-	-200	-	mV
RSDS input "High" Voltage	$V_{DIFFRSDS}$		-	200	-	mV
RSDS reference voltage	V_{CMRSDS}		VSSD+0.1	1.2	VDDD-1.2	V
Input "Low" voltage	V_{IL}	EIO1,EIO2,DIR,TP1, POL	0	-	0.2VDDD	μ A
Input "High" voltage	V_{IH}		0.8VDDD	-	VDDD	μ A
Input leak current	IL		-1	-	1	μ A
Supply current (In operation mode)	I_{CCD1}	VDDD=3.6V	-	-	Note(1)	mA
Supply current (In stand-by mode)	I_{CCD2}	VDDD=3.6V	-	-	Note(2)	mA
Pull high resistance	Rpu	/POLINV,RS, ENREOP,VC	0.9Typ	800	1.1Typ	k Ω
Pull low resistance	Rpd	POL20,/LP	0.9Typ	190	1.1Typ	k Ω

Note: (1) Test condition: TP1= 20 μ s, CLK =54MHz, data pattern =1010....checkerboard pattern, Ta=25 $^{\circ}$ C

(2) No load condition

8. Driver AC CHARACTERISTICS

Parameter	Symbol	Condition	Spec			Unit
			Min.	Typ.	Max.	
Clock pulse width	t_{CLK}	-	11	-	-	ns
Clock pulse low period	$t_{CLK(L)}$	-	5	-	-	ns
Clock pulse high period	$t_{CLK(H)}$	-	5	-	-	ns
Data setup time	t_{SETUP1}	-	2	-	-	ns
Data hold time	t_{HOLD1}	-	0	-	-	ns
Start pulse setup time	t_{SETUP2}	-	1	-	-	ns
Start pulse hold time	t_{HOLD2}	-	2	-	-	ns
TP1 high period	$t_{TP1(H)}$	-	15	-	-	CLKP
Last data CLK to TP1 high	t_{LAST}	-	0	-	-	CLKP
TP1 high to EIO high	t_{NEXT}	-	6	-	-	CLKP
POL to TP1 setup time	$t_{POL-TP1}$	POL toggle to TP1 rising	3	-	-	ns
TP1 to POL hold time	$t_{TP1-POL}$	TP1 falling to POL toggle	2	-	-	ns

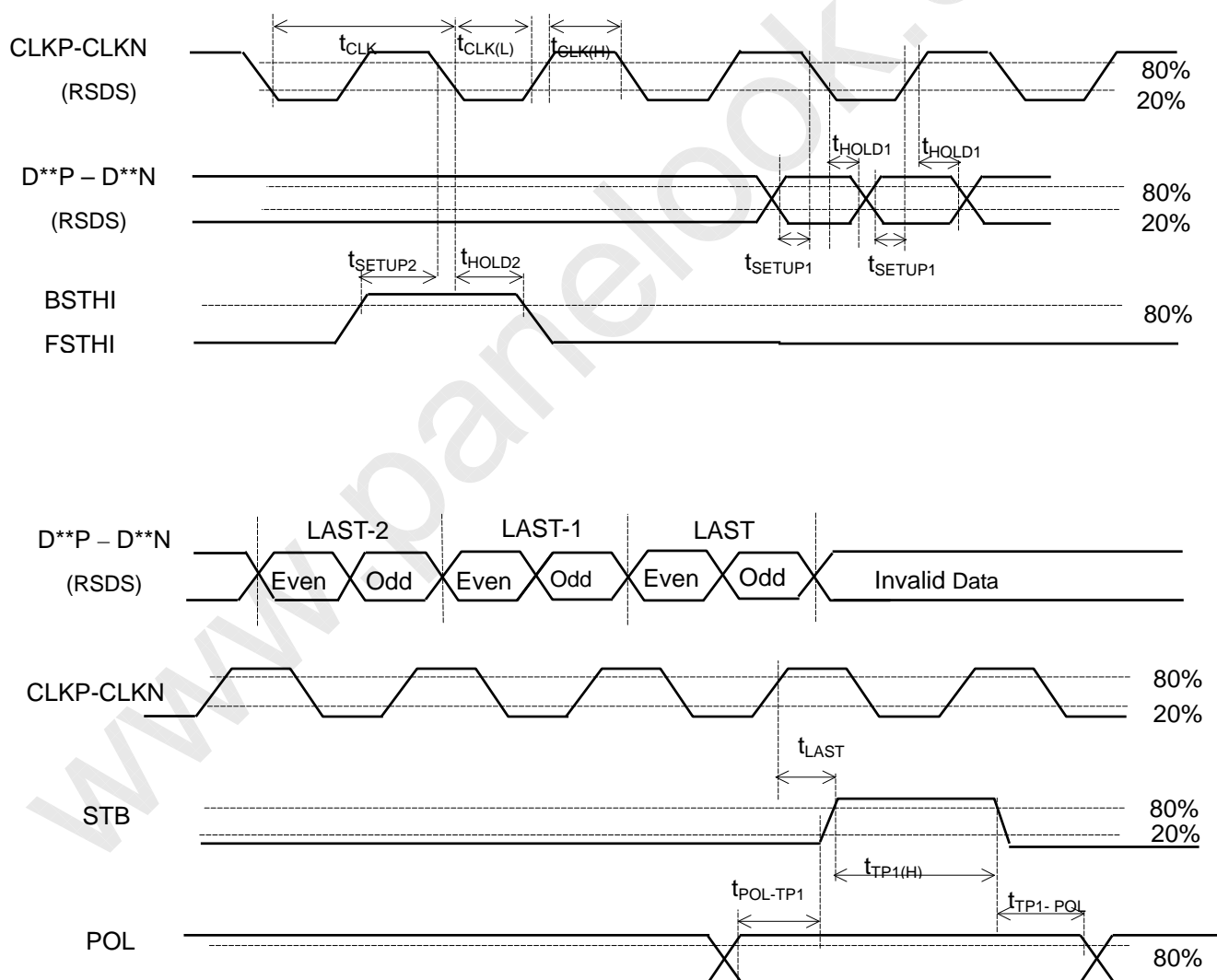

9. VERTICAL TIMING

Parameter	Symbol	Condition	Spec			Unit
			Min.	Typ.	Max.	
CKV period	t_{CKV}	-	5	-	-	μs
CKV pulse width	t_{CKVH}, t_{CKVL}	50% duty cycle	2.5	-	-	
OE pulse width	t_{OE}	-	1	-	-	
/XAO pulse width	t_{WXAO}	-	6	-	-	
Data setup time	t_{SU}	-	700	-	-	ns
Data hold time	t_{HD}	-	700	-	-	ns
OE to CKV time	t_{OE-CKV}	-	-	0.5	-	μs
STB to CKV	$t_{STB-CKV}$	-	0	0	0	μs
STB Pulse Width	t_{STB}	-	-	0.5	-	μs
GVOFF to CKV	$t_{GVOFF-CKV}$	-	-	-0.5	-	μs
GVOFF Pulse width(Note1)	t_{GVOFF}	-	-	9.0	-	μs

Note 1:GVOFF, OE, STB frequency same as CKV

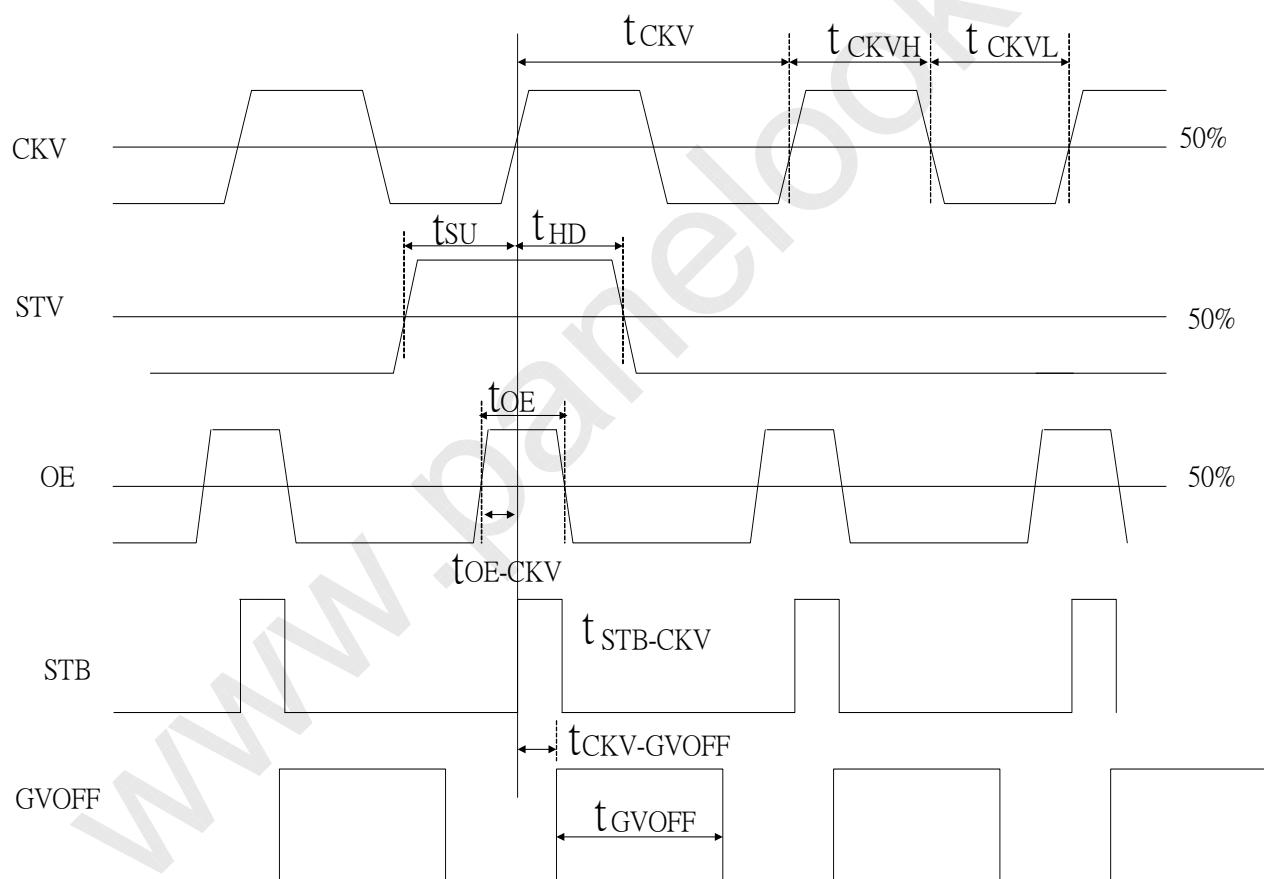

10. OPTICAL CHARACTERISTICS

10.1 TEST CONDITIONS

Item	Symbol	Value	Unit
Ambient Temperature	Ta	25±2	°C
Ambient Humidity	Ha	50±10	%RH
Supply Voltage	V _{CC}	5.0	V
Input Signal	According to typical value in "3. ELECTRICAL CHARACTERISTICS"		
Lamp Current	I _L	7.0	mA
Inverter Operating Frequency	F _L	61	KHz

10.2 OPTICAL SPECIFICATIONS

The relative measurement methods of optical characteristics are shown as below. The following items should be measured under the test conditions described in 9.1 and stable environment shown in Note (6).

Item	Symbol	Condition	Min.	Typ.	Max.	Unit	Note	
Color Chromaticity	Red	$\theta_x=0^\circ, \theta_y=0^\circ$ CS-1000T Standard light source "C"	Typ - 0.03	0.649	Typ + 0.03	-	(0),(6)	
				0.332		-		
	Green			0.274		-		
				0.589		-		
	Blue			0.148		-		
				0.101		-		
	White			0.320		-		
				0.356		-		
Center Transmittance	T%	$\theta_x=0^\circ, \theta_y=0^\circ$ CS-1000T, CMO BLU	5.4	6.0	-	%	(1), (8)	
Contrast Ratio	CR		500	700	-	-	(1), (3)	
Response Time	T _R	$\theta_x=0^\circ, \theta_y=0^\circ$	-	1.5	6.5	ms	(4)	
	T _F			3.5	8.5	ms		
Transmittance uniformity	$\delta T\%$	$\theta_x=0^\circ, \theta_y=0^\circ$ CA-210	-	1.25	1.4	-	(1), (7)	
Viewing Angle	Horizontal	CR≥10 CA-210	75	85	-	Deg.	(1), (2) (6)	
				75	85			-
	Vertical			70	80			-
				70	80			-

10.3 FLICKER ADJUSTMENT

(1) Adjustment Pattern:

Depend on User's Timing Controller Selection

(2) Adjustment Method:

Flicker should be adjusted by turning the duty of VCM_PWM (refer to 5.1). It is adjusted to the point with least flickering of the whole screen. After making it surely overrun at once, it should be adjusted to the optimum point.

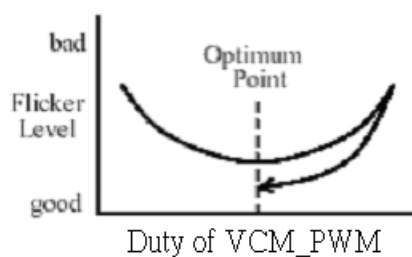

Note (0) Light source is the standard light source "C" which is defined by CIE and driving voltages are based on suitable gamma voltages. The calculating method is as following :

Measure Module's and BLU's spectrums. White is without signal input and R, G, B are with signal input.

BLU(for A190A2 BLU) is supplied by CMO.

Calculate cell's spectrum.

Calculate cell's chromaticity by using the spectrum of standard light source "C"

Note (1) Light source is the BLU which is supplied by CMO and driving voltages are based on suitable gamma voltages.

Note (2) Definition of Viewing Angle (θ_x, θ_y):

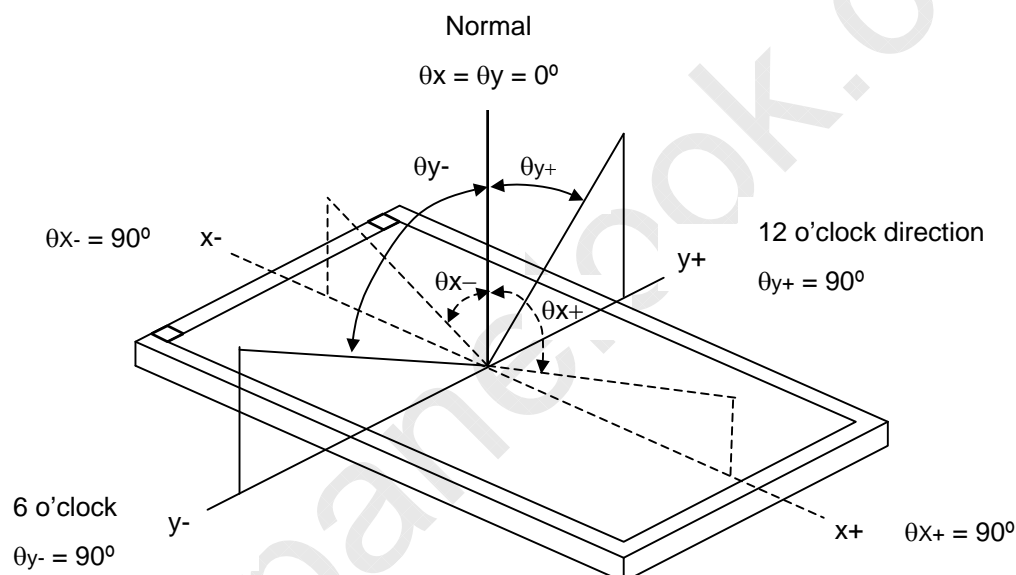

Note (3) Definition of Contrast Ratio (CR):

The contrast ratio can be calculated by the following expression.

$$\text{Contrast Ratio (CR)} = L_{255} / L_0$$

L255: Luminance of gray level 255

L 0: Luminance of gray level 0

$$\text{CR} = \text{CR} (1)$$

CR (X) is corresponding to the Contrast Ratio of the point X at Figure in Note (7).

Note (4) Definition of Response Time (T_R , T_F):

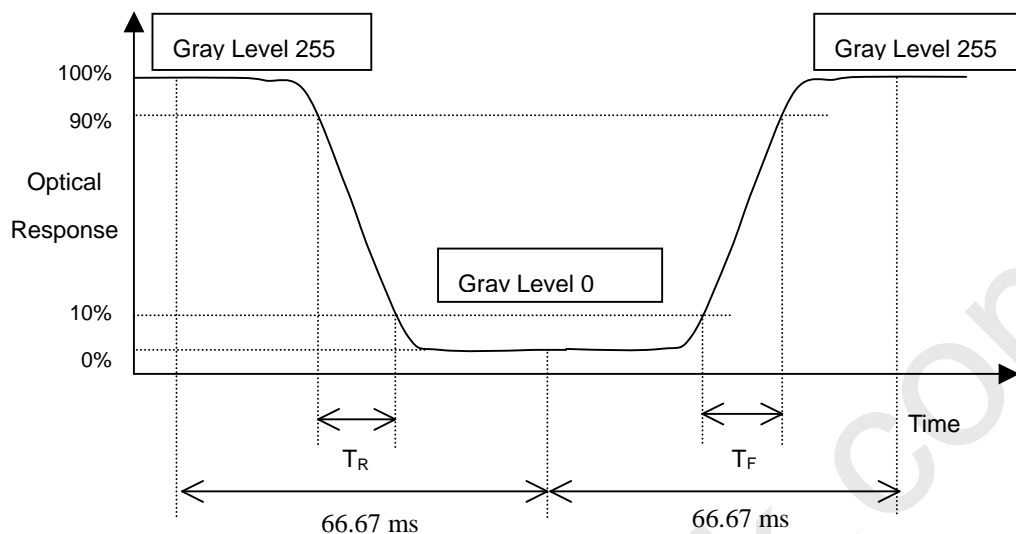

Note (5) Definition of Luminance of White (L_C):

Measure the luminance of gray level 255 at center point

$$L_C = L(1)$$

$L(x)$ is corresponding to the luminance of the point X at Figure in Note (7).

Note (6) Measurement Setup:

The LCD module should be stabilized at given temperature for 20 minutes to avoid abrupt temperature change during measuring. In order to stabilize the luminance, the measurement should be executed after lighting Backlight for 20 minutes in a windless room.

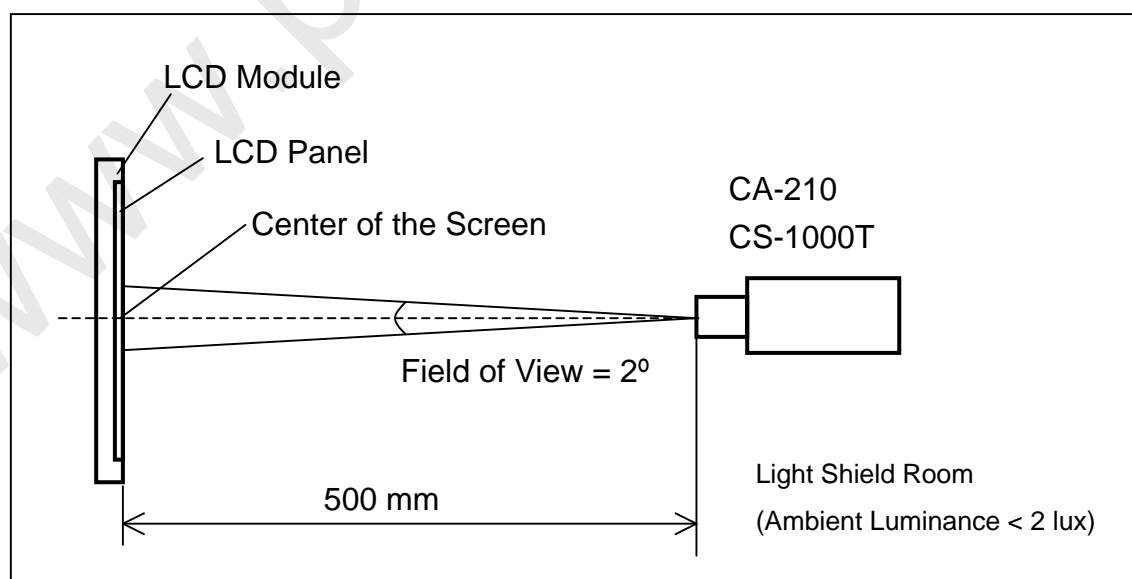

Note (7) Definition of Transmittance Variation ($\delta T\%$):

Measure the transmittance at 13 points

$$\delta T\% = \frac{\text{Maximum [L (1), L (2), \dots, L (12), L (13)]}}{\text{Minimum [L (1), L (2), \dots, L (12), L (13)]}}$$

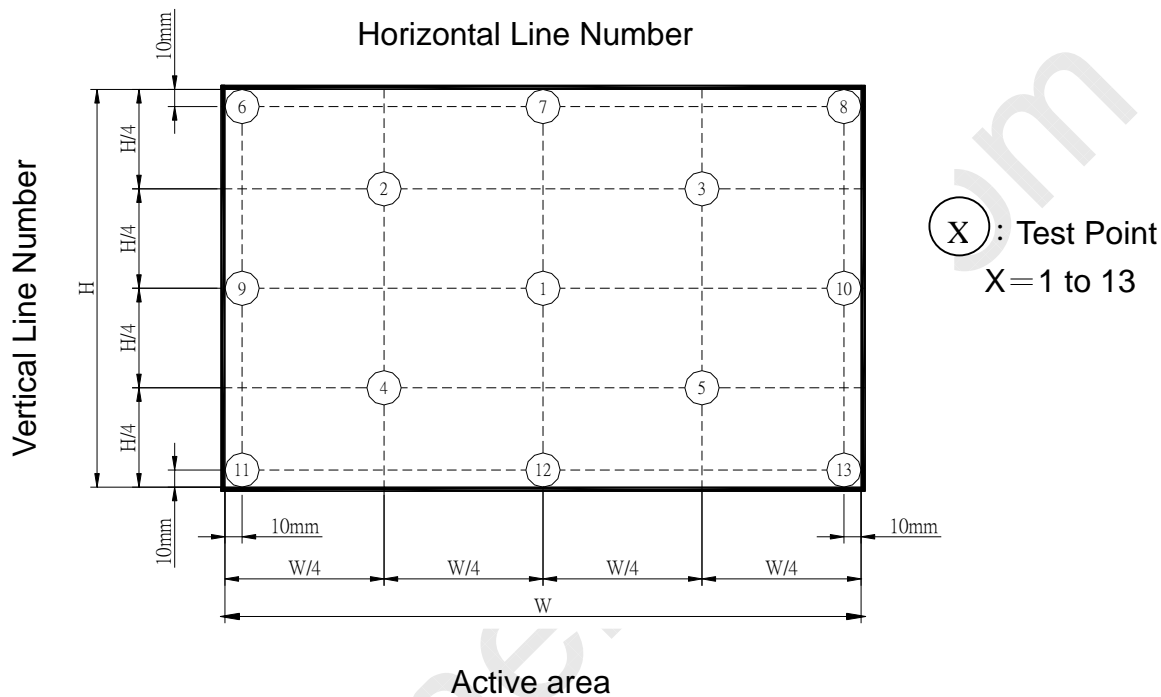

Note (8) Definition of Transmittance ($T\%$):

Module is without signal input.

$$\text{Transmittance} = \frac{\text{Luminance of LCD module}}{\text{Luminance of backlight}} * 100\%$$

11. PACKAGING

11.1 PACKING SPECIFICATIONS

- (1) 15 open cells / 1 Box
- (2) Box dimensions: 615 (L) X 515 (W) X 385 (H) mm
- (3) Weight: approximately 14.8Kg (15 open cells per box)

11.2 PACKING METHOD

- (1) Carton Packing should have no failure in the following reliability test items-

Test Item	Test Conditions	Note
Packing Vibration	ISTA STANDARD Random, Frequency Range: 1 – 200 Hz Top & Bottom: 30 minutes (+Z), 10 min (-Z), Right & Left: 10 minutes (X) Back & Forth 10 minutes (Y)	Non Operation

- (2) Packing method.

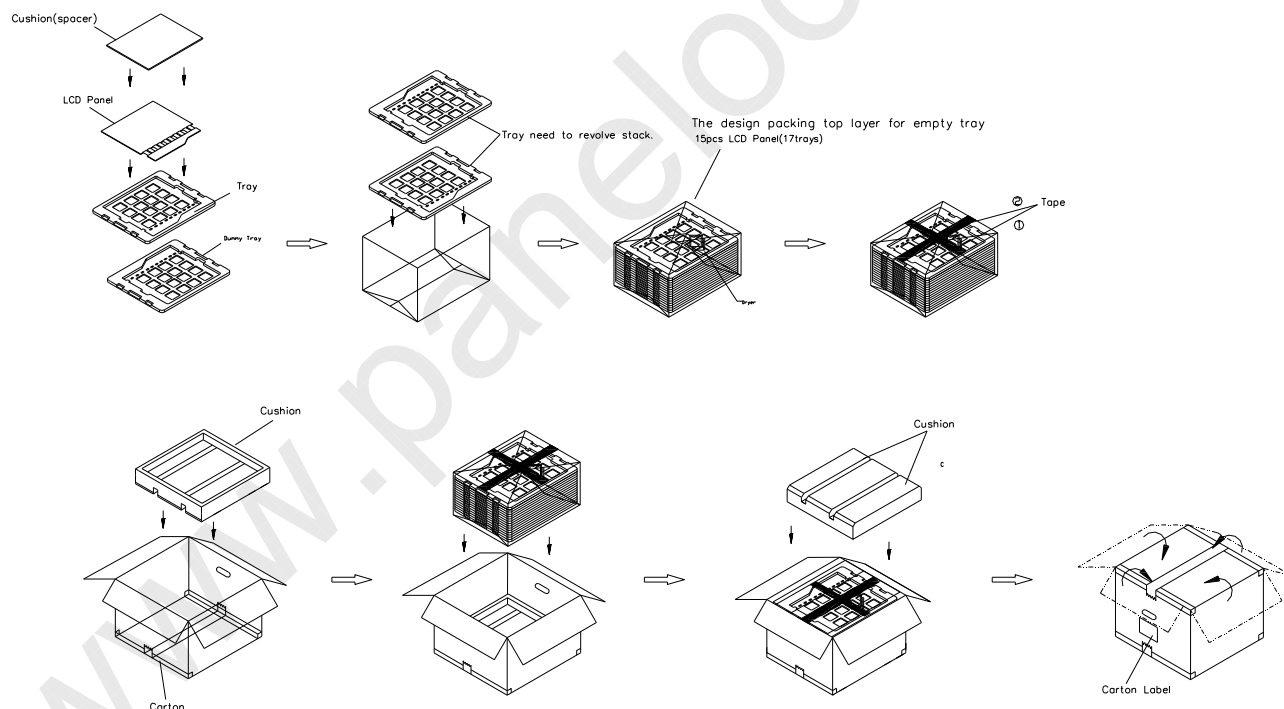

- (1) 15 LCD Cells+PCB/1 box
- (2) Carton dimensions : 615(L)x515(W)x385(H)mm
- (3) Weight : approximately 14.8kg(15 Cells per Carton).

Sea and Land Transportation

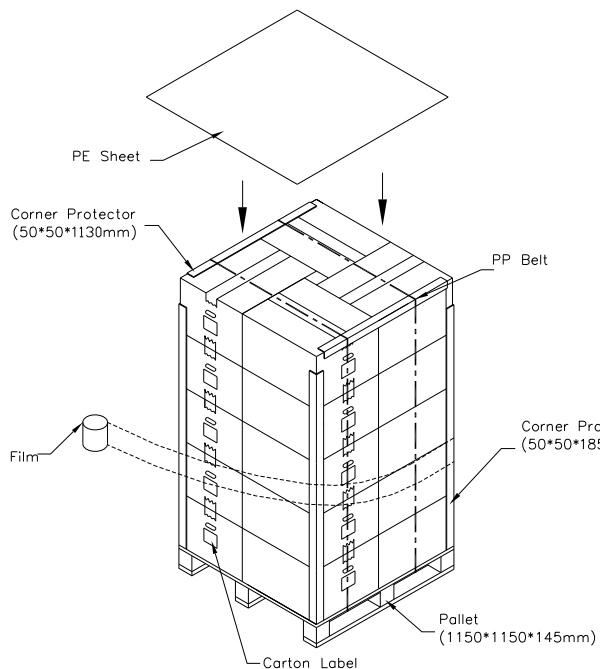

Air Transportation

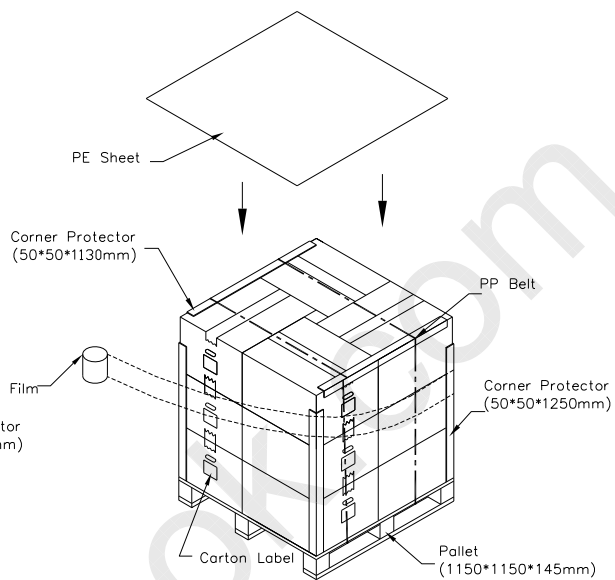

12. DEFINITION OF LABELS

12.1 CMO OPEN CELL LABEL

The barcode nameplate is pasted on each OPEN CELL as illustration for CMO internal control.



Barcode definition:

Serial ID: CM-19A11-X-X-X-XX-L-XX-L-YMD-NNNN

Code	Meaning	Description
CM	Supplier code	CMO=CM
19A11	Model number	M19A1-PS1=19A11
X	Revision code	C1:1, C2:2,...
X	Source driver IC code	Century=1, CLL=2, Demos=3, Epson=4, Fujitsu=5, Himax=6, Hitachi=7, Hynix=8, LDI=9, Matsushita=A, NEC=B, Novatec=C, OKI=D, Philips=E, Renasas=F, Samsung=G, Sanyo=H, Sharp=I, TI=J, Topro=K, Toshiba=L, Windbond=M
X	Gate driver IC code	
XX	Cell location	Tainan, Taiwan=TN
L	Cell line #	0~12=1~C
XX	Module location	Tainan, Taiwan=TN
L	Module line #	0~12=1~C
YMD	Year, month, day	Year: 2001=1, 2002=2, 2003=3, 2004=4... Month: 1~12=1, 2, 3, ~, 9, A, B, C Day: 1~31= 1, 2, 3, ~, 9, A, B, C, ~, T, U, V
NNNN	Serial number	Manufacturing sequence of product

12.2 CARTON LABEL

The barcode nameplate is pasted on each box as illustration, and its definitions are as following explanation

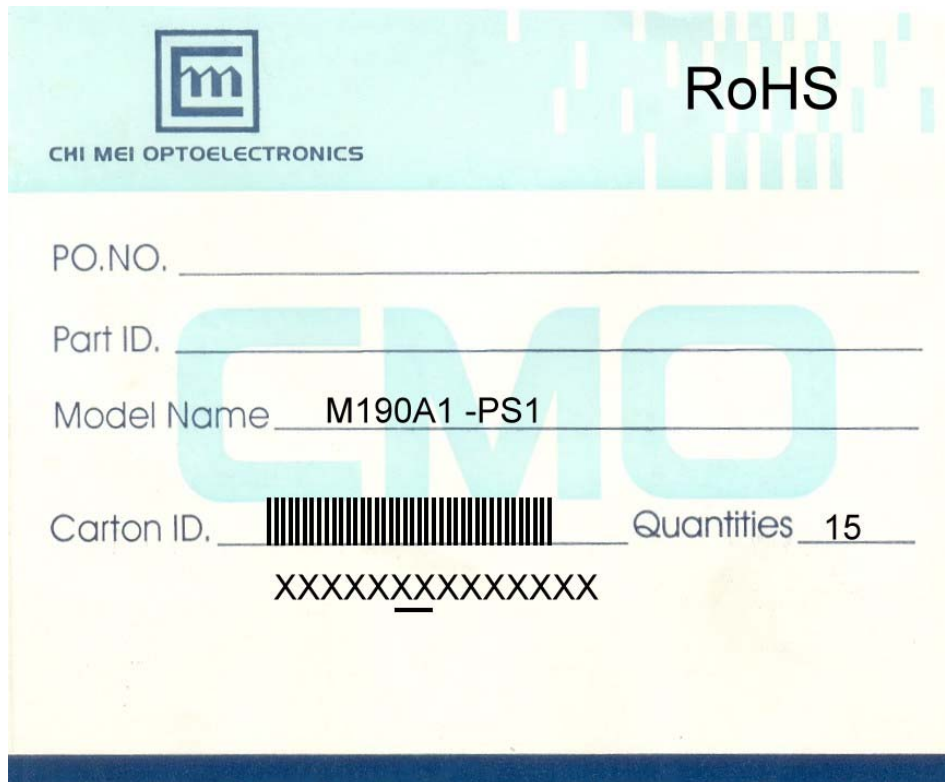

CHI MEI OPTOELECTRONICS

RoHS

PO.NO. _____

Part ID. _____

Model Name M190A1-PS1

Carton ID.  Quantities 15

XXXXXXXXXXXXXXXX

Model Name: M190A1-PS1

Carton ID: CMO internal control

Quantities: 15 pcs

13. PRECAUTIONS

13.1 ASSEMBLY AND HANDLING PRECAUTIONS

- (1) Do not apply rough force such as bending or twisting to the product during assembly.
- (2) To assemble backlight or install module into user's system can be only in clean working areas. The dust and oil may cause electrical short or worsen the polarizer.
- (3) It's not permitted to have pressure or impulse on the module because the LCD panel will be damaged.
- (4) Always follow the correct power sequence when the product is connecting and operating. This can prevent damage to the CMOS LSI chips during latch-up.
- (5) Do not pull the I/F connector in or out while the module is operating.
- (6) Use a soft dry cloth without chemicals for cleaning, because the surface of polarizer is very soft and easily scratched.
- (7) It is dangerous that moisture come into or contacted the product, because moisture may damage the product when it is operating.
- (8) High temperature or humidity may reduce the performance of module. Please store this product within the specified storage conditions.
- (9) When ambient temperature is lower than 10°C may reduce the display quality. For example, the response time will become slowly.

13.2 SAFETY PRECAUTIONS

- (1) If the liquid crystal material leaks from the panel, it should be kept away from the eyes or mouth. In case of contact with hands, skin or clothes, it has to be washed away thoroughly with soap.
- (2) After the product's end of life, it is not harmful in case of normal operation and storage.

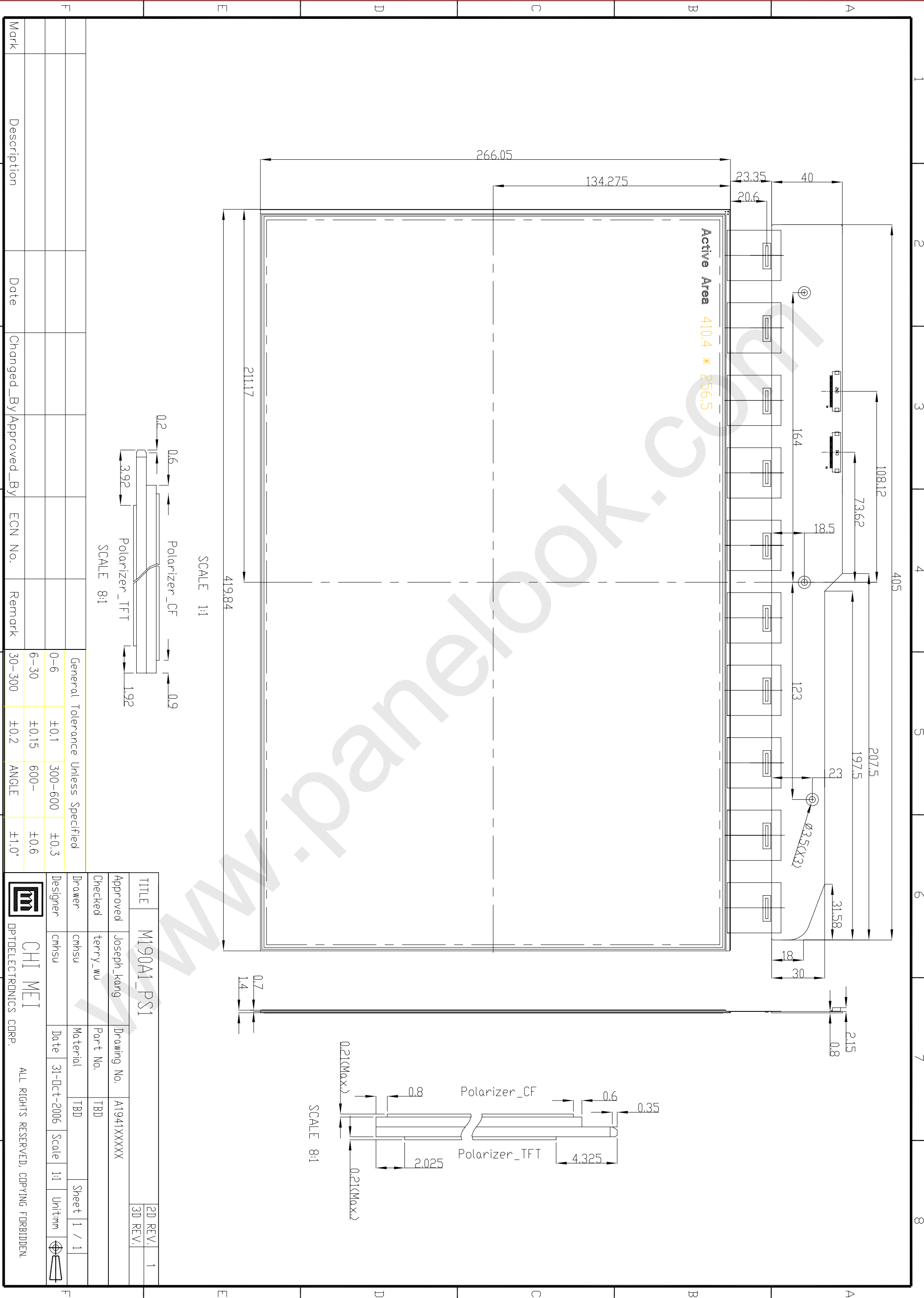

SCALE 8:1

SCALE 1:1

SCALE 8:1

Mark	1	2	3	4	5	6	7	8
Description								
Date								
Changed_By/Approved_By								
ECN No.								
Remark								
General Tolerance Unless Specified	0-6	±0.1	300-600	±0.3	6-30	±0.15	600-	±0.6
	30-300	±0.2	ANGLE	±1.0°				

TITLE	M190A1_PS1		2D REV.	1
Approved	Joseph_kang	Drawing No.	A1941XXXXX	3D REV.
Checked	terry_wu	Part No.	TBD	
Designer	cmhsu	Material	TBD	Sheet 1 / 1
Date	31-Oct-2006	Scale	1:1	Unit:mm

CHI MEI
OPTOELECTRONICS CORP.
ALL RIGHTS RESERVED, COPYING FORBIDDEN.