



# Product Specification

M190EG02 V9

AU OPTRONICS CORPORATION

(V) Preliminary Specification

( ) Final Specification

<b>Module</b>	19.0" SXGA Color TFT-LCD
<b>Model Name</b>	M190EG02 V9

<b>Customer</b>	<b>Date</b>
_____	_____
<b>Approved by</b>	
_____	_____
<p>Note: This Specification is subject to change without notice.</p>	

<b>Checked &amp; Approved by</b>	<b>Date</b>
<b>Prepared by</b>	
<p>Desktop Display Business Group / AU Optronics corporation</p>	

AUO Confidential For STAR Internal Use Only / 2011/12/30

## Contents

<b>1. Handling Precautions .....</b>	<b>4</b>
<b>2. General Description .....</b>	<b>5</b>
2.1 Display Characteristics .....	5
2.2 Optical Characteristics .....	6
<b>3. Functional Block Diagram.....</b>	<b>10</b>
<b>4. Absolute Maximum Ratings.....</b>	<b>11</b>
4.1 TFT LCD Module .....	11
4.2 Backlight Unit .....	11
4.3 Absolute Ratings of Environment.....	11
<b>5. Electrical characteristics .....</b>	<b>12</b>
5.1 TFT LCD Module .....	12
5.2 Backlight Unit .....	15
<b>6. Signal Characteristic .....</b>	<b>16</b>
6.1 Pixel Format Image .....	16
6.2 The input data format.....	16
6.3 Signal Description .....	17
6.4 Interface Timing.....	19
6.5 Power ON/OFF Sequence.....	21
<b>7. Connector &amp; Pin Assignment .....</b>	<b>22</b>
7.1 TFT LCD Module .....	22
7.2 Connector on Backlight Unit.....	23
<b>8. Reliability Test.....</b>	<b>24</b>
<b>9. Shipping Label .....</b>	<b>25</b>
<b>10. Mechanical Characteristic.....</b>	<b>26</b>

AUO Confidential For STAR Internal Use Only / 2017/12/30



## Record of Revision

Version & Date	Page	Old Description	New Description	Remark
0.1 2011/11/04	All	Frist Edition for Customer		
0.2 2011/11/23	23/26	Backlight connector type no. 3707K-Q06N-01R	Backlight connector type no. 3707K-S06N-01R	
	15/26	LT <sub>LED</sub> : LED life Time (Typical) : Min 25000 , Typical 30000	LT <sub>LED</sub> : LED life Time (Typical) : Min 30000 , Typical -	
0.3 2011/11/28	21/26	Parameter T5 : Typ. 1500msec	Parameter T5 : Typ. --msec	
0.4 2011/12/09	19/26	Interface Timing Characteristics : Vertical Section / Period / Tv / Max : 1150 Horizontal Section / Blanking / Tbp(h)+Tfp(h)+PWhs / Max : - Clock / Period / Tclk / Min : 22.2 Clock / Frequency / Freq / Min : 45 Frame Rate / Frequency / 1/Tv / Max : 75	Interface Timing Characteristics : Vertical Section / Period / Tv / Max: 1186 Horizontal Section / Blanking / Tbp(h)+Tfp(h)+PWhs / Max : 1407 Clock / Period / Tclk / Min : 25.0 Clock / Frequency / Freq / Min: 40 Frame Rate / Frequency / 1/Tv / Max: 76	

AUO Confidential For STAR Internal Use Only / 2011/12/30

## 1. Handling Precautions

- 1) Since front polarizer is easily damaged, pay attention not to scratch it.
- 2) Be sure to turn off power supply when inserting or disconnecting from input connector.
- 3) Wipe off water drop immediately. Long contact with water may cause discoloration or spots.
- 4) When the panel surface is soiled, wipe it with absorbent cotton or other soft cloth.
- 5) Since the panel is made of glass, it may break or crack if dropped or bumped on hard surface.
- 6) Since CMOS LSI is used in this module, take care of static electricity and insure human earth when handling.
- 7) Do not open or modify the Module Assembly.
- 8) Do not press the reflector sheet at the back of the module to any directions.
- 9) In case if a Module has to be put back into the packing container slot after once it was taken out from the container, do not press the center of the LED lightbar edge. Instead, press at the far ends of the LED light bar edge softly. Otherwise the TFT Module may be damaged.
- 10) At the insertion or removal of the Signal Interface Connector, be sure not to rotate nor tilt the Interface Connector of the TFT Module.
- 11) After installation of the TFT Module into an enclosure, do not twist nor bend the TFT Module even momentary. At designing the enclosure, it should be taken into consideration that no bending/twisting forces are applied to the TFT Module from outside. Otherwise the TFT Module may be damaged.
- 12) Small amount of materials having no flammability grade is used in the LCD module. The LCD module should be supplied by power complied with requirements of Limited Power Source (IEC60950 or UL1950), or be applied exemption.
- 13) Pls avoid touching COF position while you are doing mechanical design
- 14) When storing modules as spares for a long time, the following precaution is necessary:  
Store them in a dark place. Do not expose the module to sunlight or fluorescent light. Keep the temperature between 5°C and 35°C at normal humidity.

## 2. General Description

M190EG02 V9 is a Color Active Matrix Liquid Crystal Display composed of a TFT-LCD panel, a driver circuit, and a backlight system. The screen format is intended to support the SXGA (1280(H) x 1024(V)) screen and 16.7M colors (RGB 6-bits + HiFRC data). All input signals are 2-channel LVDS interface compatible. Inverter card of backlight is not included. M190EG02 V9 is designed for a display unit of personal computer.

### 2.1 Display Characteristics

The following items are characteristics summary on the table under 25 °C condition:

Items	Unit	Specifications
Screen Diagonal	[mm]	482.6 (19.0" )
Active Area	[mm]	376.32 (H) x 301.06 (V)
Pixels H x V		1280(x3) x 1024
Pixel Pitch	[mm]	0.294 (per one triad) x 0.294
Pixel Arrangement		R.G.B. Vertical Stripe
Display Mode		Normally White
White Luminance	[cd/m <sup>2</sup> ]	250 (center, Typ) @60.0mA
Contrast Ratio		1000 : 1 (Typ)
Optical ResponseTime	[msec]	5 ms(Typ, on/off)
Nominal Input Voltage VDD	[Volt]	+5.0 V
Power Consumption	[Watt]	15.1 W (Typ) (PDD= 4.5 W, PLED=10.6 W )
Weight	[Grams]	1800 (Typ)
Physical Size (H x V x D)	[mm]	396 (H) x 324 (V) x 10.9(D) (Typ)
Electrical Interface		Dual channel LVDS
Surface Treatment		Hard-coating (3H), Non-Glare treatment
Support Color		16.7M colors (RGB 6-bit + Hi_FRC)
Temperature Range		
Operating	[°C]	0 to +50
Storage (Non-Operating)	[°C]	-20 to +60
RoHS Compliance		RoHS Compliance
TCO Compliance		TCO 5.1 Compliance

## 2.2 Optical Characteristics

The optical characteristics are measured under stable conditions at 25°C (Room Temperature):

Item	Unit	Conditions	Min.	Typ.	Max.	Note
Viewing Angle	[degree]	Horizontal (Right) CR = 10 (Left)	75 75	85 85	-	2
		Vertical (Up) CR = 10 (Down)	70 70	80 80	-	
Contrast Ratio		Normal Direction	600	1000	-	3
Optical Response Time	[msec]	Raising Time (TrR)	-	3.6	5.7	4
		Falling Time (TrF)	-	1.4	2.3	
		Rising + Falling	-	5	8	
Color / Chromaticity Coordinates (CIE)		Red x	0.609	0.639	0.669	5
		Red y	0.316	0.346	0.376	
		Green x	0.294	0.324	0.354	
		Green y	0.597	0.627	0.657	
		Blue x	0.124	0.154	0.184	
		Blue y	0.024	0.054	0.084	
		White x	0.283	0.313	0.343	
White y	0.299	0.329	0.359			
Central Luminance	[cd/m <sup>2</sup> ]		200	250	-	6
Luminance Uniformity	[%]	9 Points	75	80	-	7
Cross Talk (At 60Hz)	[%]		-	-	1.5	8
Flicker	[dB]		-	-	-20	9

**Note 1: Measurement method**

The LCD module should be stabilized at given temperature for 30 minutes to avoid abrupt temperature change during measuring (at surface 35°C). In order to stabilize the luminance, the measurement should be executed after lighting Backlight for 30 minutes in a stable, windless and dark room.

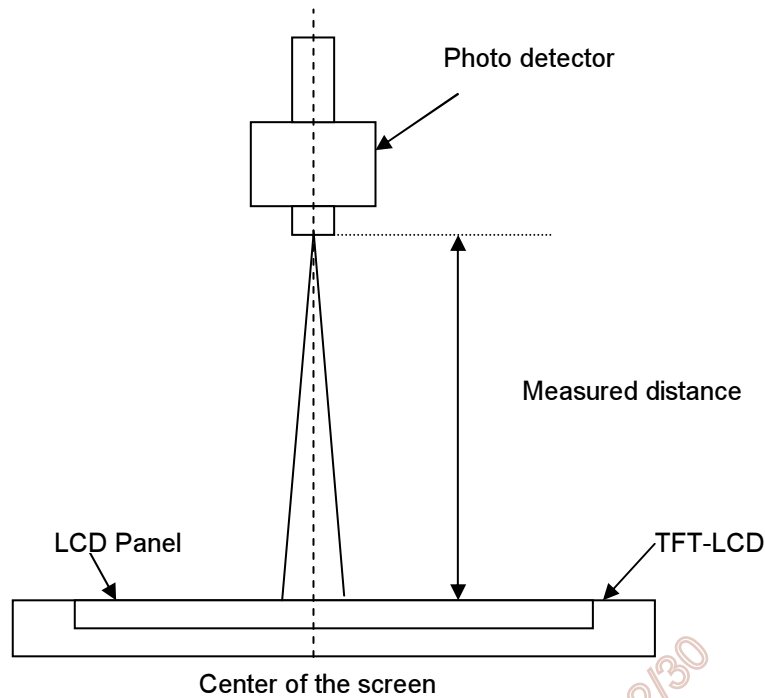

**Note 2: Definition of viewing angle measured by ELDIM (EZContrast 88)**

Viewing angle is the measurement of contrast ratio  $\geq 10$ , at the screen center, over a 180° horizontal and 180° vertical range (off-normal viewing angles). The 180° viewing angle range is broken down as follows; 90° ( $\theta$ ) horizontal left and right and 90° ( $\phi$ ) vertical, high (up) and low (down). The measurement direction is typically perpendicular to the display surface with the screen rotated about its center to develop the desired measurement viewing angle.

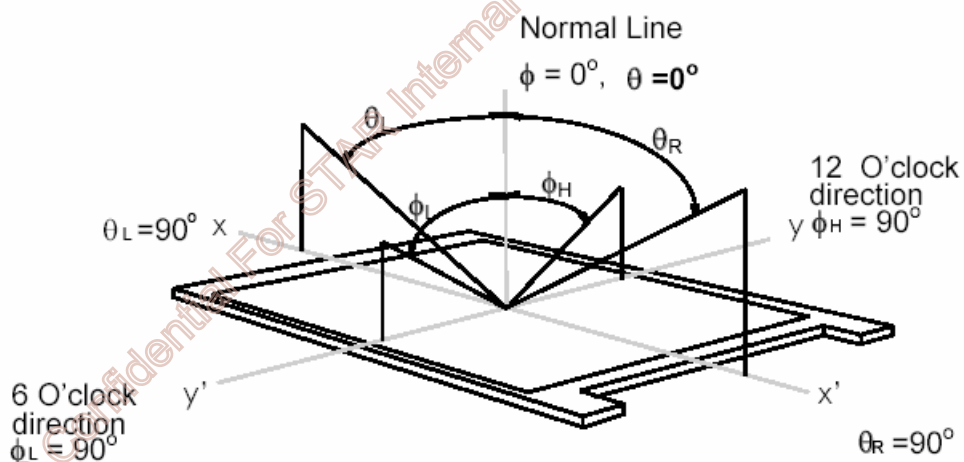

**Note 3: Contrast ratio is** measured by TOPCON SR-3

**Note 4: Definition of Response time** measured by Westar TRD-100A

The output signals of photo detector are measured when the input signals are changed from “Full Black” to “Full White” (rising time,  $T_{rR}$ ), and from “Full White” to “Full Black” (falling time,  $T_{rF}$ ), respectively. The response time is interval between the 10% and 90% (1 frame at 60 Hz) of amplitudes.

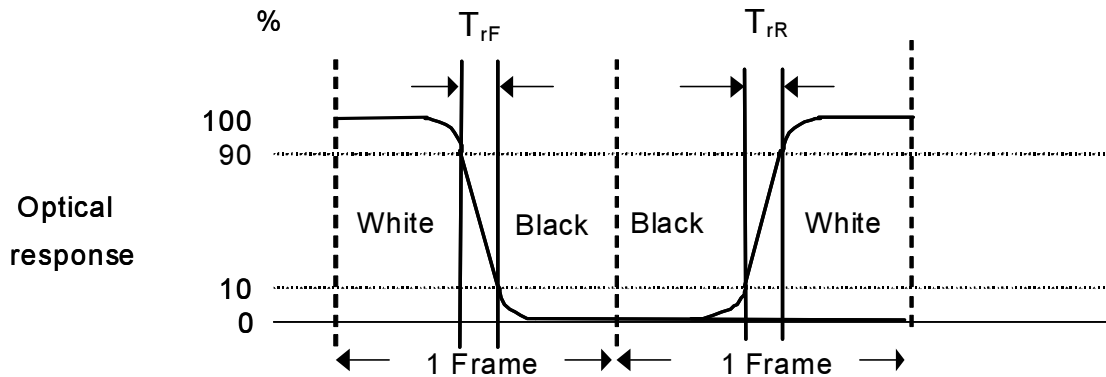

$$T_{rR} + T_{rF} = 5 \text{ msec (typ.)}$$

**Note 5: Color chromaticity and coordinates (CIE)** is measured by TOPCON SR-3

**Note 6: Central luminance** is measured by TOPCON SR-3

**Note 7: Luminance uniformity of these 9 points** is defined as below and measured by TOPCON SR-3

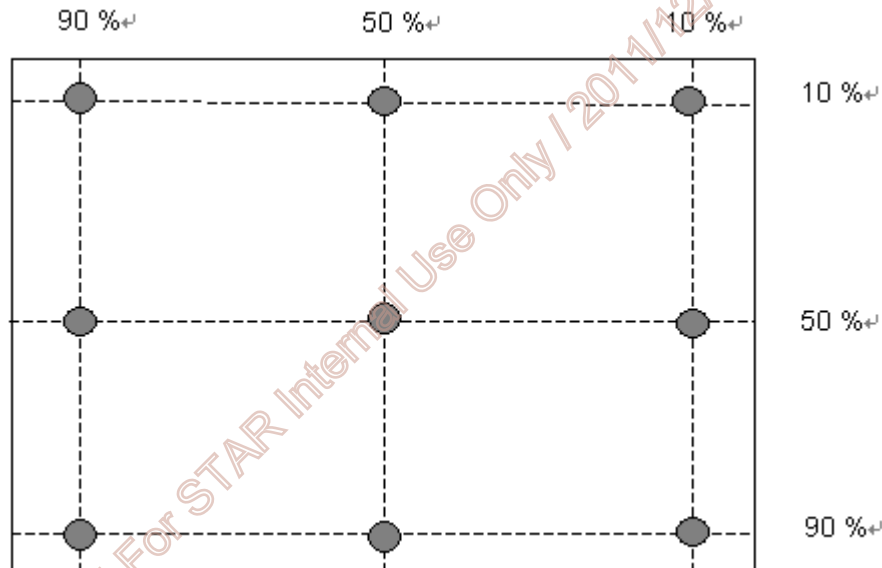

$$\text{Uniformity} = \frac{\text{Minimum Luminance in 9 points (1-9)}}{\text{Maximum Luminance in 9 Points (1-9)}}$$

**Note 8: Crosstalk** is defined as below and measured by TOPCON SR-3



$$CT = |YB - YA| / YA \times 100 (\%)$$

Where

YA = Luminance of measured location without gray level 0 pattern (cd/m<sup>2</sup>)

YB = Luminance of measured location with gray level 0 pattern (cd/m<sup>2</sup>)

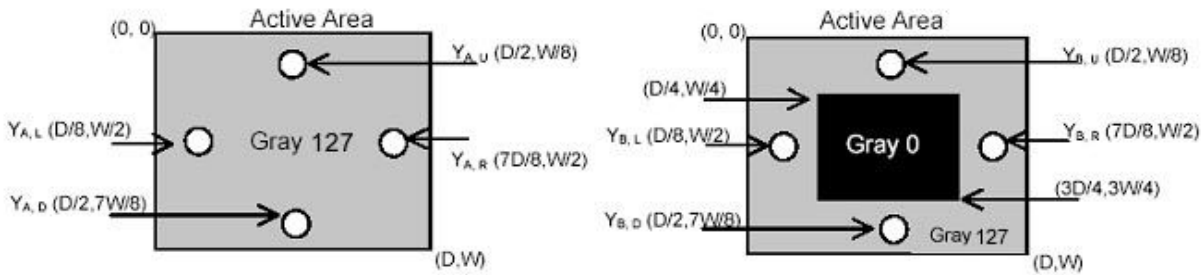

**Note 9: Test Pattern: Subchecker Pattern** measured by TOPCON SR-3

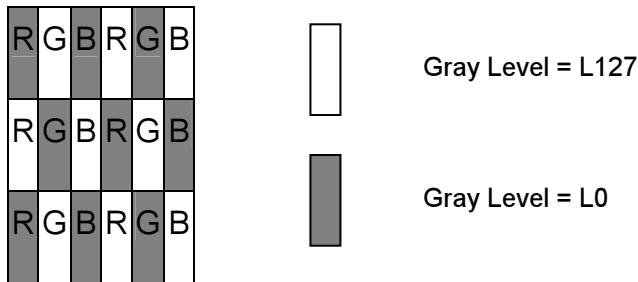

Method: Record dBV & DC value with TRD-100

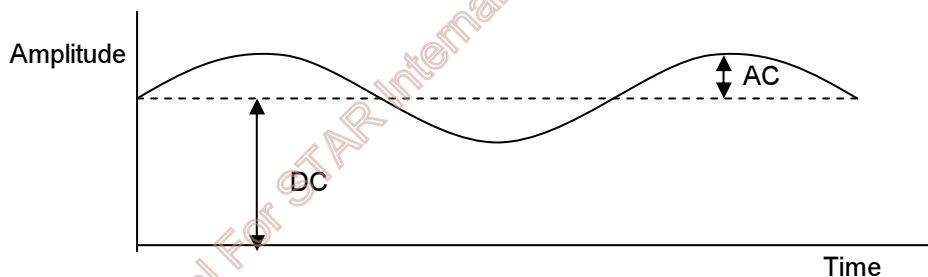

$$\text{Flicker (dB)} = 20 \log \frac{\text{AC Level (at 30 Hz)}}{\text{DC Level}}$$

## 3. Functional Block Diagram

The following diagram shows the functional block of the 19.0 inch Color TFT-LCD Module:

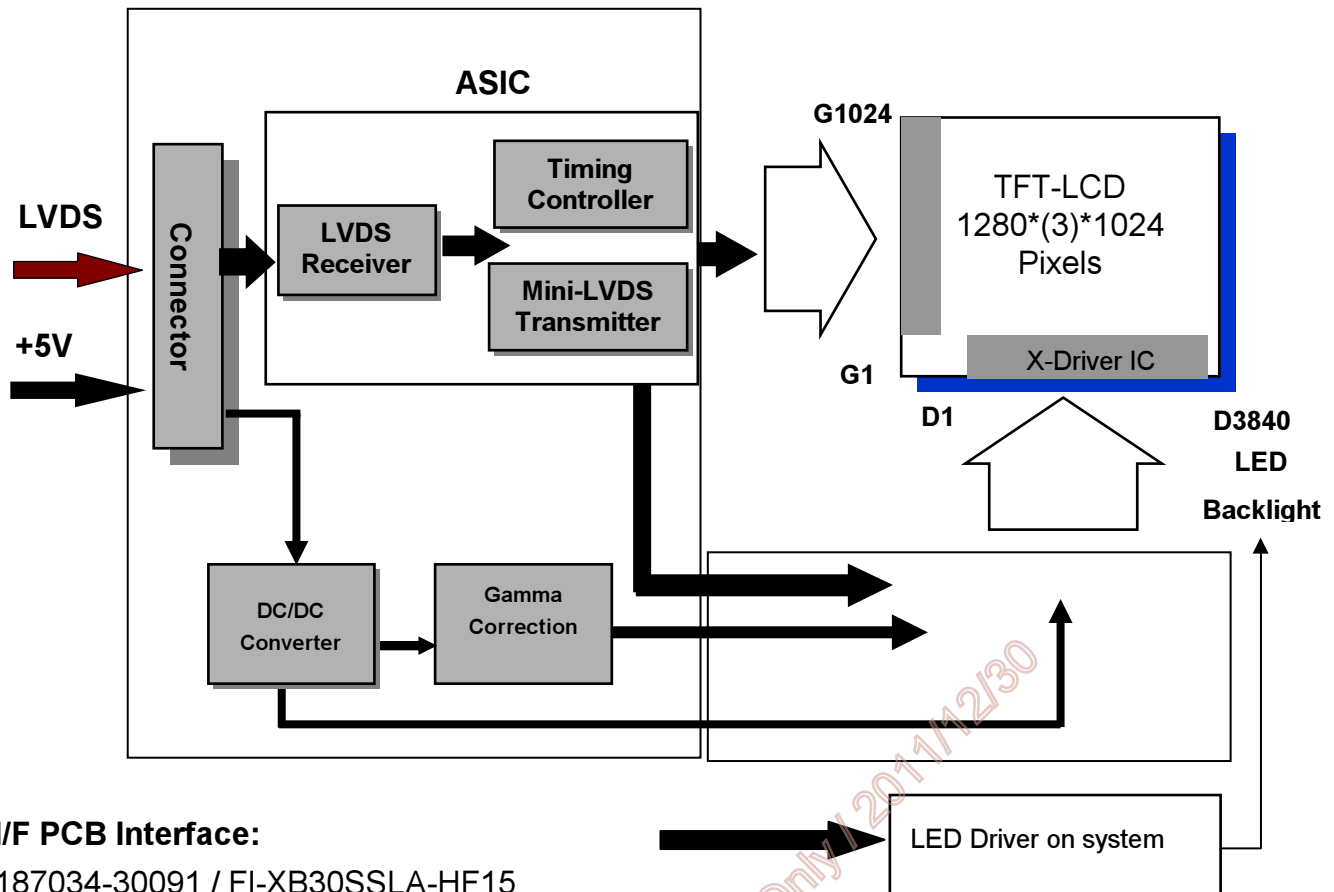

### I/F PCB Interface:

187034-30091 / FI-XB30SSLA-HF15

### Mating Type:

FI-X30HL (Locked Type)

FI-X30H (Unlocked Type)

## 4. Absolute Maximum Ratings

Absolute maximum ratings of the module are as following:

### 4.1 TFT LCD Module

Item	Symbol	Min	Max	Unit	Conditions
Logic/LCD Drive Voltage	VDD	-0.3	+6.0	[Volt]	<b>Note 1,2</b>

### 4.2 Backlight Unit

Item	Symbol	Min	Max	Unit	Conditions
LED Current	ILED	-	90	[mA]	<b>Note 1,2</b>

### 4.3 Absolute Ratings of Environment

Item	Symbol	Min.	Max.	Unit	Conditions
Operating Temperature	TOP	0	+50	[°C]	<b>Note 3</b>
Glass surface temperature (operation)	TGS	0	+65	[°C]	<b>Note 3, Note 4</b>
Operation Humidity	HOP	5	90	[%RH]	<b>Note 3</b>
Storage Temperature	TST	-20	+60	[°C]	
Storage Humidity	HST	5	90	[%RH]	

**Note 1:** With in Ta (25□)

**Note 2:** Permanent damage to the device may occur if exceeding maximum values

**Note 3:** Temperature and relative humidity range are shown as the below figure.

1. 90% RH Max ( Ta ≤ 39°C )
2. Max wet-bulb temperature at 39°C or less. ( Ta ≤ 39°C )
3. No condensation

**Note 4:** Function Judged only

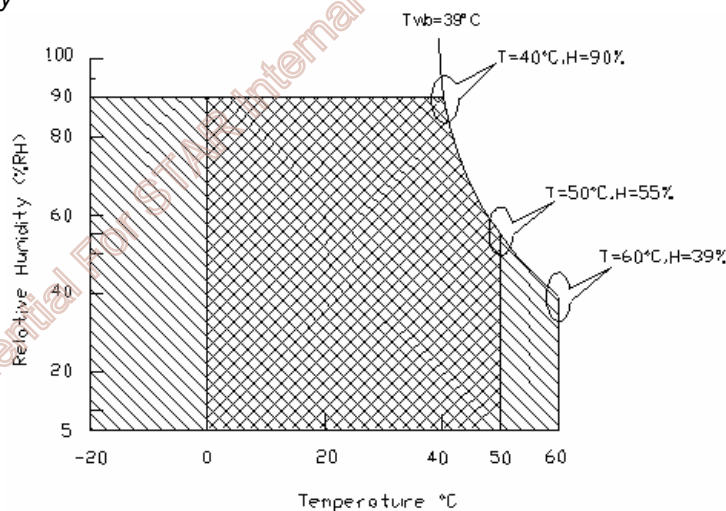

Operating Range



Storage Range



## 5. Electrical characteristics

### 5.1 TFT LCD Module

#### 5.1.1 Power Specification

Input power specifications are as following:

Symbol	Parameter	Min	Typ	Max	Unit	Conditions
VDD	Logic/LCD Drive Voltage	4.5	5.0	5.5	[Volt]	+/-10%
IDD	Input Current	-	0.75	0.90	[A]	VDD= 5.0V, All Black Pattern At 60Hz,
		-	0.91	1.10		VDD= 5.0V, All Black Pattern At 75Hz,
PDD	VDD Power	-	3.8	4.5	[Watt]	VDD= 5.0V, All Black Pattern At 60Hz
		-	4.5	5.5		VDD= 5.0V, All Black Pattern At 75Hz
IRush	Inrush Current	-	-	3.0	[A]	Note 1
VDDrp	Allowable Logic/LCD Drive Ripple Voltage	-	-	500	[mV] p-p	VDD= 5.0V, All Black Pattern At 75Hz

**Note 1:** Measurement conditions:

The duration of rising time of power input is 470us.

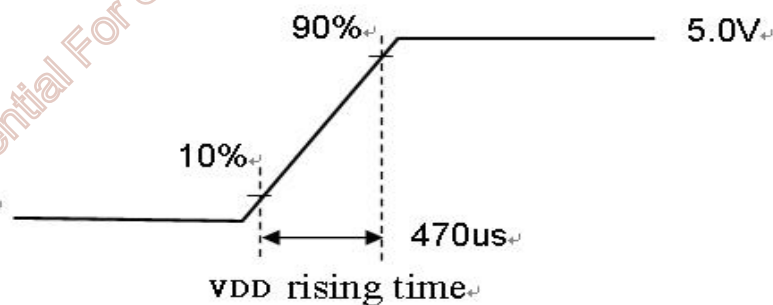
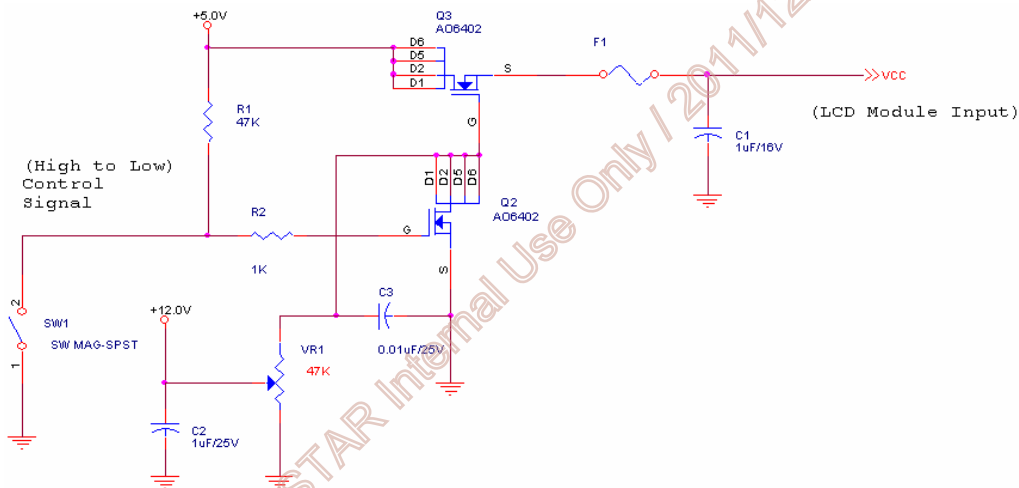

## 5.1.2 Signal Electrical Characteristics

Input signals shall be low or Hi-Z state when VDD is off. Please refer to specifications of SN75LVDS82DGG (Texas Instruments) in detail.

### 1. DC Characteristics of each signal are as following:

Symbol	Parameter	Min	Typ	Max	Units	Condition
$V_{TH}$	Differential Input High Threshold	-	-	+100	[mV]	$V_{CM} = 1.2V$ <b>Note 1</b>
$V_{TL}$	Differential Input Low Threshold	-100	-	-	[mV]	$V_{CM} = 1.2V$ <b>Note 1</b>
$ V_{ID} $	Input Differential Voltage	100	400	600	[mV]	<b>Note 1</b>
$V_{CM}$	Differential Input Common Mode Voltage	+1.0	+1.2	+1.5	[V]	$V_{TH}-V_{TL} = 200mV$ (max) <b>Note 1</b>

#### Note 1: LVDS Signal Waveform

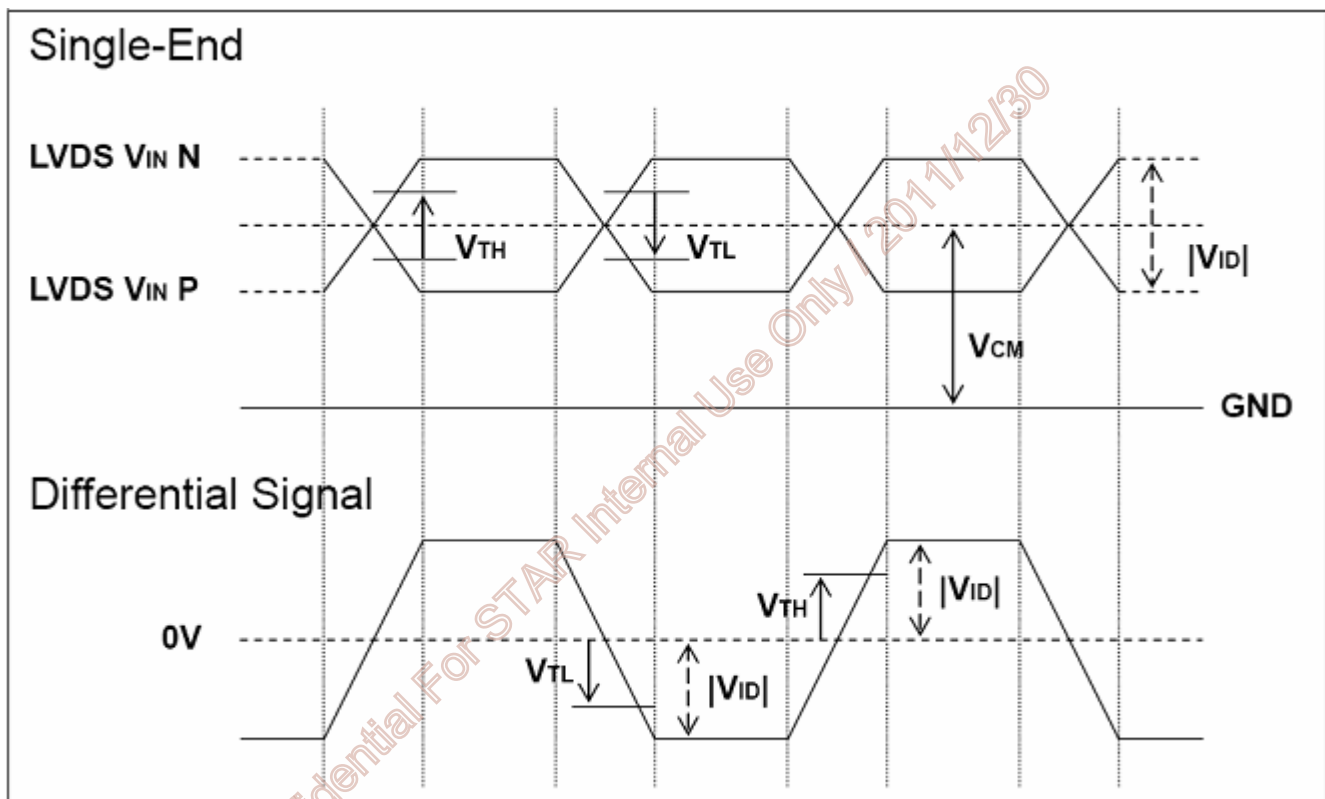

## 2. AC characteristic

Description	Symbol	Min	Max	Unit	Note
Maximum deviation of input clock frequency during SSC	$F_{DEV}$	-	$\pm 3$	%	
Maximum modulation frequency of input clock during SSC	$F_{MOD}$	-	200	KHz	

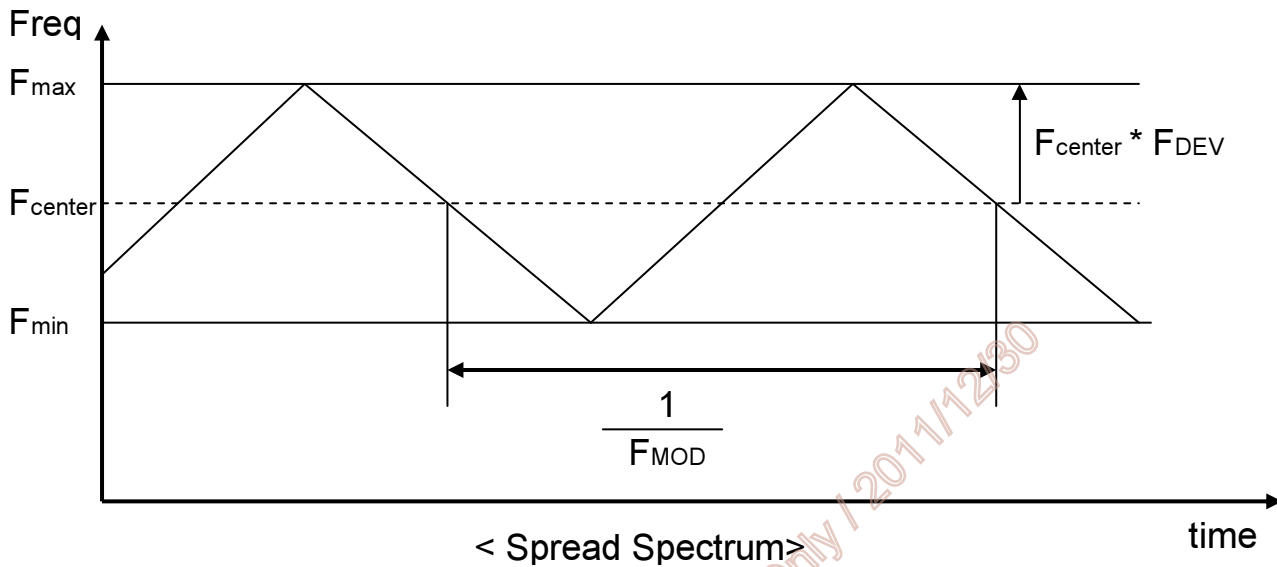

AUO Confidential For STAR Internal Use Only / 2011/12/30

## 5.2 Backlight Unit

Parameter guideline for LED driving is under stable conditions at 25°C (Room Temperature):

Symbol	Parameter	Min.□	Typ.	Max.	Unit	Note
$I_{R_{LED}}$	LED Operation Current	-	60		[mA] Note 1	<b>Operating with fixed driving current</b>
$V_{LB}$	Light Bar Operation Voltage (for reference)	-	41.6	46.8	[Volt] Note 2	
$P_{BLU}$	BLU Power consumption (for reference)	-	9.98	11.2	[Watt]	
$LT_{LED}$	LED life Time (Typical)	30,000	-		[Hour] Note 3	

Note 1 :The specified current is input LED chip 100% duty current.

Note 2 : The value showed in the table is one light bar's operation voltage.

Note 3 : Definition of life time : brightness becomes 50% of its original value. The minimum life time of LED unit is on the condition of  $I_{R_{LED}} = 60\text{mA}$  and  $25\pm 2^\circ\text{C}$  (Room temperature).

Note 4: Each LED light bar consists of 52 pcs LED package ( 4 strings x 13 pcs / string ).

AUO Confidential For STAR Internal Use Only / 2011/12/30



## 6. Signal Characteristic

### 6.1 Pixel Format Image

Following figure shows the relationship of the input signals and LCD pixel format.

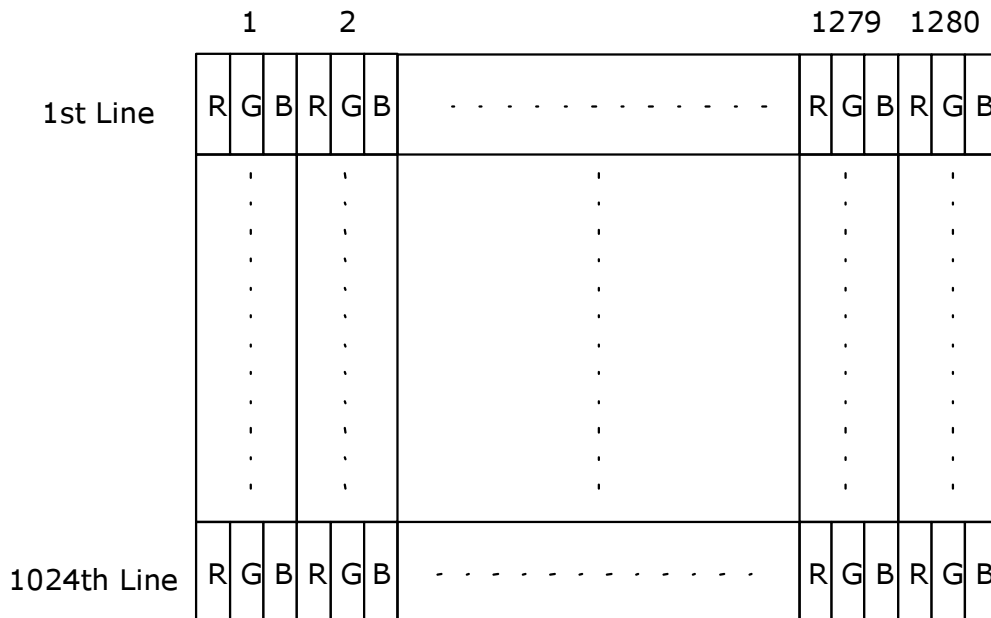

### 6.2 The input data format

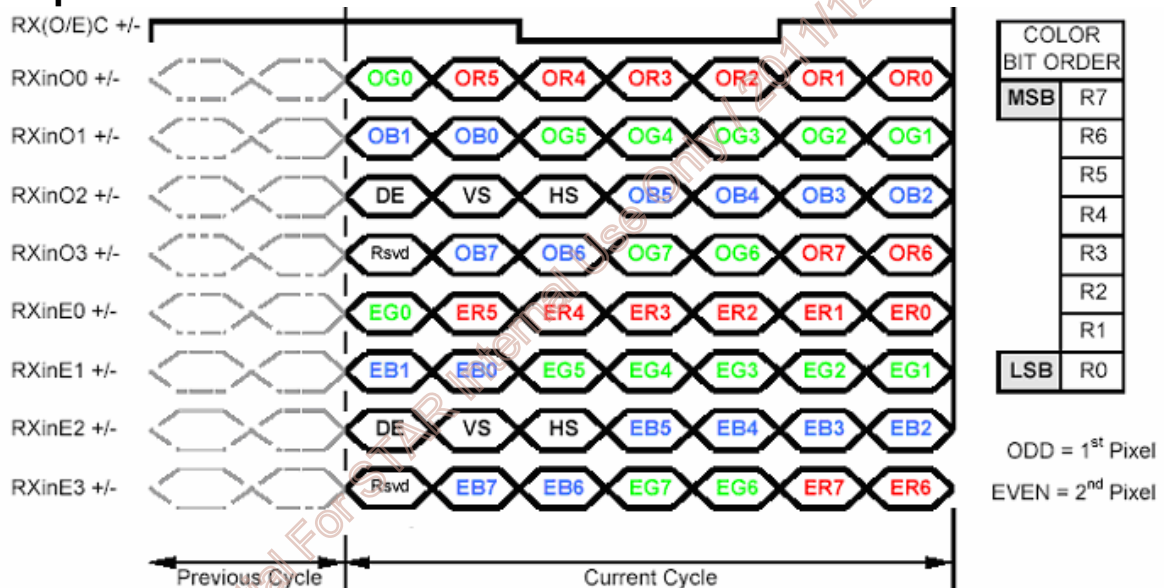

Note1: Normally, DE, VS, HS on EVEN channel are not used.

Note2: Please follow PSWG.

Note3: 8-bit in



## 6.3 Signal Description

The module using one LVDS receiver SN75LVDS82(Texas Instruments). LVDS is a differential signal technology for LCD interface and high speed data transfer device. LVDS transmitters shall be SN75LVDS83(negative edge sampling). The first LVDS port(RxOxxx) transmits odd pixels while the second LVDS port(RxExxx) transmits even pixels.

PIN #	SIGNAL NAME	DESCRIPTION
1	RxOIN0-	Negative LVDS differential data input (Odd data)
2	RxOIN0+	Positive LVDS differential data input (Odd data)
3	RxOIN1-	Negative LVDS differential data input (Odd data)
4	RxOIN1+	Positive LVDS differential data input (Odd data)
5	RxOIN2-	Negative LVDS differential data input (Odd data, DSPTMG)
6	RxOIN2+	Positive LVDS differential data input (Odd data, DSPTMG)
7	GND	Power Ground
8	RxOCLKIN-	Negative LVDS differential clock input (Odd clock)
9	RxOCLKIN+	Positive LVDS differential clock input (Odd clock)
10	RxOIN3-	Negative LVDS differential data input (Odd data)
11	RxOIN3+	Positive LVDS differential data input (Odd data)
12	RxEIN0-	Negative LVDS differential data input (Even data)
13	RxEIN0+	Positive LVDS differential data input (Even data)
14	GND	Power Ground
15	RxEIN1-	Positive LVDS differential data input (Even data)
16	RxEIN1+	Negative LVDS differential data input (Even data)
17	GND	Power Ground
18	RxEIN2-	Negative LVDS differential data input (Even data)
19	RxEIN2+	Positive LVDS differential data input (Even data)
20	RxECLKIN-	Negative LVDS differential clock input (Even clock)
21	RxECLKIN+	Positive LVDS differential clock input (Even clock)
22	RxEIN3-	Negative LVDS differential data input (Even data)
23	RxEIN3+	Positive LVDS differential data input (Even data)
24	GND	Power Ground
25	GND	Power Ground
26	NC	No connection (for AUO test)
27	NC	No connection (for AUO test)
28	POWER	Power +5V
29	POWER	Power +5V
30	POWER	Power +5V

Note1: Start from left side

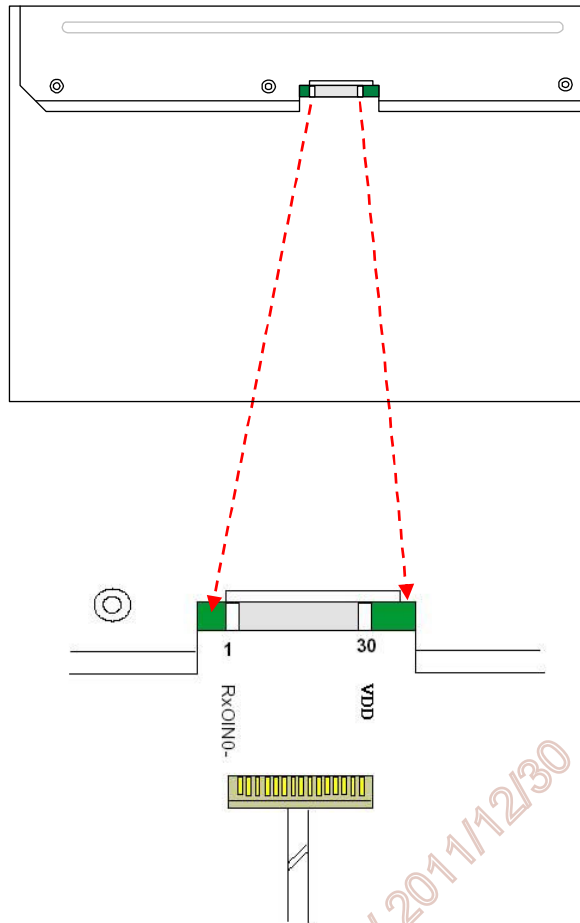

Note2: Input signals of odd and even clock shall be the same timing.

AUO Confidential For STAR Internal Use Only / 2011/12/30



## 6.4 Interface Timing

### 6.4.1 Timing Characteristics

Signal	Item	Symbol	Min	Typ	Max	Unit
Vertical Section	Period	$T_v$	1032	1066	1186	Th
	Active	$T_{disp(v)}$	1024	1024	1024	Th
	Blanking	$T_{bp(v)}+T_{fp(v)}+PW_{vs}$	8	42	126	Th
Horizontal Section	Period	$T_h$	780	844	2047	Tclk
	Active	$T_{disp(h)}$	640	640	640	Tclk
	Blanking	$T_{bp(h)}+T_{fp(h)}+PW_{hs}$	140	204	1407	Tclk
Clock	Period	Tclk	25.0	18.52	14.81	ns
	Frequency	Freq.	40	54	67.5	MHz
Frame Rate	Frequency	$1/T_v$	50	60	76	Hz

Note : DE mode only

AUO Confidential For STAR Internal Use Only / 2011/12/30

## 6.4.2 Timing Diagram

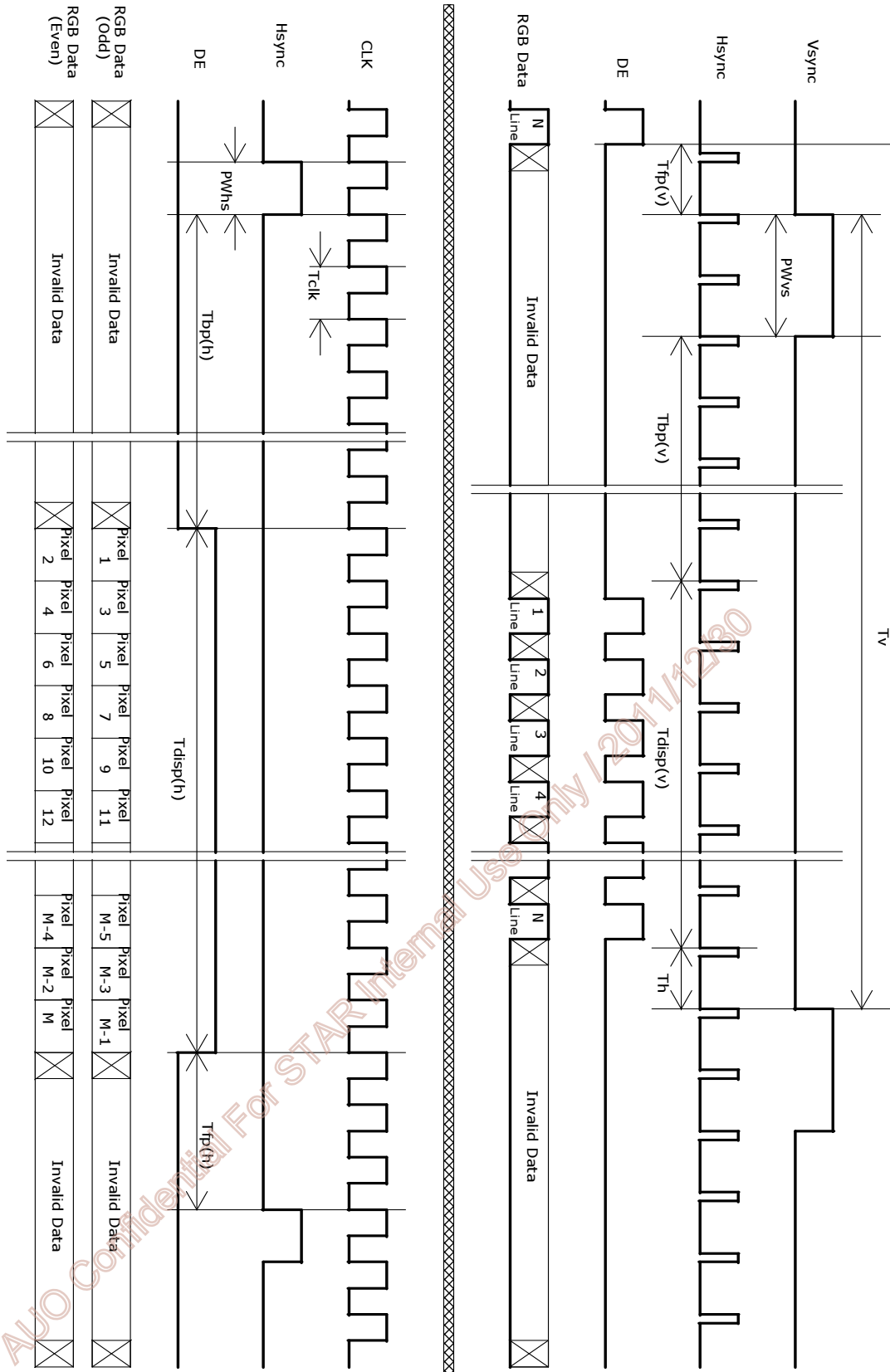

## 6.5 Power ON/OFF Sequence

VDD power and lamp on/off sequence are as follows. Interface signals are also shown in the chart. Signals from any system shall be Hi-Z state or low level when VDD is off.

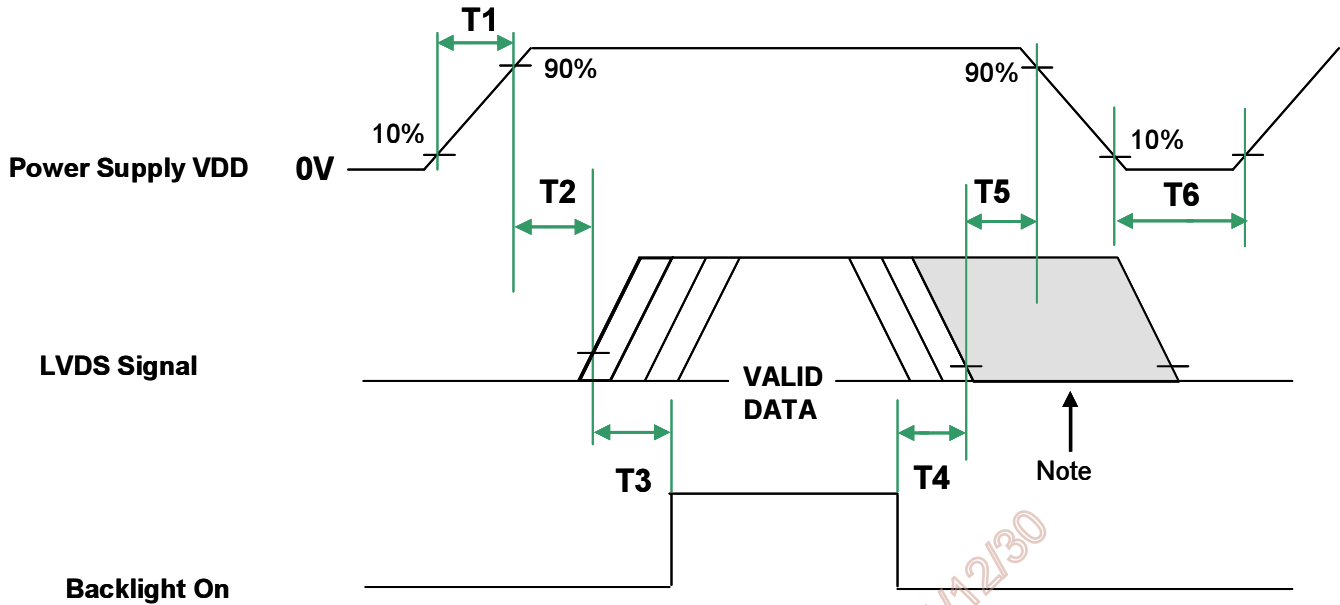

Note : Insert a white pattern after valid data and last until VDD falls to 10%

Parameter	Value		Unit
	Min.	Max.	
T1	0.5	10	[msec]
T2	0	50	[msec]
T3	500	-	[msec]
T4	200	-	[msec]
T5	40	-	[msec]
T6	1000	-	[msec]

## 7. Connector & Pin Assignment

Physical interface is described as for the connector on module. These connectors are capable of accommodating the following signals and will be following components.

### 7.1 TFT LCD Module

#### 7.1.1 Connector

Connector Name / Designation	Interface Connector / Interface card
Manufacturer	P-TWO / JAE
Type Part Number	187034-30091 / FI-XB30SSLA-HF15
Mating Housing Part Number	FI-X30HL FI-X30H (Unlocked Type)

#### 7.1.2 Pin Assignment

Pin#	Signal Name	Pin#	Signal Name
1	RxOIN0-	2	RxOIN0+
3	RxOIN1-	4	RxOIN1+
5	RxOIN2-	6	RxOIN2+
7	GND	8	RxOCLKIN-
9	RxOCLKIN+	10	RxOIN3-
11	RxOIN3+	12	RxEIN0-
13	RxEIN0+	14	GND
15	RxEIN1-	16	RxEIN1+
17	GND	18	RxEIN2-
19	RxEIN2+	20	RxECLKIN-
21	RxECLKIN+	22	RxEIN3-
23	RxEIN3+	24	GND
25	GND	26	NC
27	NC	28	POWER
29	POWER	30	POWER

## 7.2 Connector on Backlight Unit.

This connector is mounted on LED light-bar.

Connector Name / Designation	Light Bar Connector
Manufacturer	ENTERY INDUSTRIAL CO., LTD
Type Part Number	3707K-S06N-01R

### 7.2.1 Pin assignment

Pin no.	Signal name
1	IRLED (current out)
2	IRLED (current out)
3	VLED (voltage in)
4	VLED (voltage in)
5	IRLED (current out)
6	IRLED (current out)

AUO Confidential For STAR Internal Use Only / 2011/12/25

## 8. Reliability Test

Environment test conditions are listed as following table.

Items	Required Condition	Note
Temperature Humidity Bias (THB)	Ta= 50□, 80%RH, 300hours	
High Temperature Operation (HTO)	Ta= 50□, 50%RH, 300hours	
Low Temperature Operation (LTO)	Ta= 0□, 300hours	
High Temperature Storage (HTS)	Ta= 60□, 300hours	
Low Temperature Storage (LTS)	Ta= -20□, 300hours	
Vibration Test (Non-operation)	Acceleration: 1.5 G Wave: Random Frequency: 10 - 200 - 10 Hz Sweep: 30 Minutes each Axis (X, Y, Z)	
Shock Test (Non-operation)	Acceleration: 50 G Wave: Half-sine Active Time: 20 ms Direction: ±X, ±Y, ±Z (one time for each Axis)	
Drop Test	Height: 60 cm, package test	
Thermal Shock Test (TST)	-20□/30min, 60□/30min, 100 cycles	1
On/Off Test	On/10sec, Off/10sec, 30,000 cycles	
ESD (ElectroStatic Discharge)	Contact Discharge: ± 8KV, 150pF(330Ω ) 1sec, 9 points, 25 times/ point.	2
	Air Discharge: ± 15KV, 150pF(330Ω ) 1sec 9 points, 25 times/ point.	
Altitude Test	Operation:10,000 ft Non-Operation:30,000 ft	

Note 1: The TFT-LCD module will not sustain damage after being subjected to 100 cycles of rapid temperature change. A cycle of rapid temperature change consists of varying the temperature from -20□ to 60□, and back again. Power is not applied during the test. After temperature cycling, the unit is placed in normal room ambient for at least 4 hours before power on.

Note 2: According to EN61000-4-2 , ESD class B:

Some performance degradation allowed.

No data lost.

Self-recoverable.

No hardware failures.



## 9. Shipping Label

The shipping label format is shown as below.

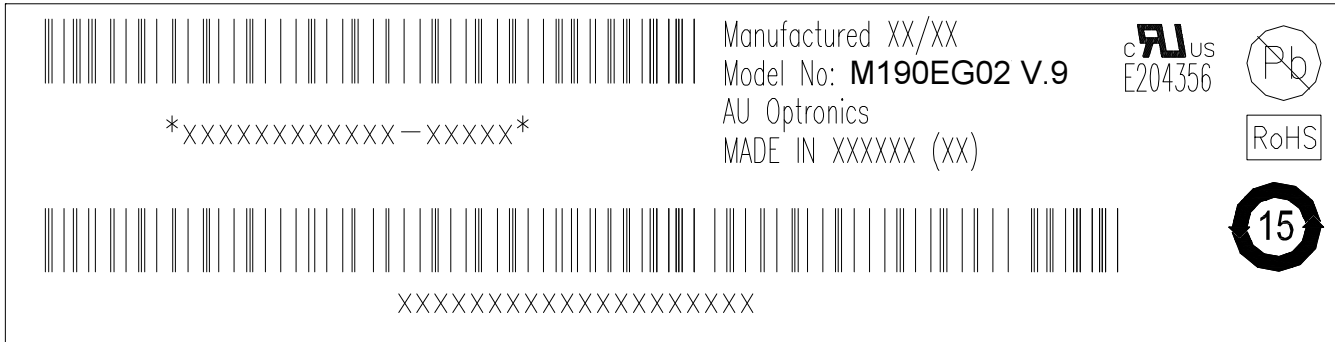

**Note 1:** For Pb Free products, AUO will add  for identification.

**Note 2:** For RoHS compatible products, AUO will add  for identification.

**Note 3:** For China RoHS compatible products, AUO will add  for identification.

**Note 4:** The Green Mark will be presented only when the green documents have been ready by AUO Internal Green Team.

AUO Confidential For STAR Internal Use Only / 2011/12/30

### 10. Mechanical Characteristic

