



## InfoVision Optoelectronics (Kunshan)Co., Ltd.

Document Title	M190MWW4 R1 Module Product Specification		Page No.	1/30	
Document No.		Issue date	2010/10/09	Revision	V00

### Product Information(Tentative)

To:

**Product Name: M190MWW4**

R1

**Document Issue Date: 2010/10/09**

Customer	InfoVision Optoelectronics
<u>SIGNATURE</u>	<u>SIGNATURE</u>
_____	REVIEWED BY
_____	QA
_____	_____
-	PREPARED BY
Please return 1 copy for your confirmation with your signature and comments.	FAE
	_____

Note: 1. Please contact InfoVision Company. Before designing your product based on this product.

2. The information contained herein is presented merely to indicate the characteristics and performance of our products. No responsibility is assumed by IVO for any intellectual property claims or other problems that may result from application based on the module described herein.

FQ-7-30-0-009-03D





## InfoVision Optoelectronics (Kunshan)Co., Ltd.

Document Title	M190MWW4 R1 Module Product Specification		Page No.	3/30	
Document No.		Issue date	2010/10/09	Revision	V00

### Contents

1.0	General Descriptions .....	p.4
2.0	Absolute Maximum Ratings .....	p.6
3.0	Pixel Format Image .....	p.7
4.0	Optical Characteristics .....	p.8
5.0	Backlight Characteristics.....	p.11
6.0	Electrical Characteristics .....	p.13
7.0	Interface Timings.....	p.20
8.0	Power Consumption .....	p.21
9.0	Power ON/OFF sequence .....	p.22
10.0	Mechanical Characteristic.....	p.23
11.0	Package Specification .....	p.26
12.0	Lot Mark.....	p.27
13.0	General Precaution .....	p.28



## InfoVision Optoelectronics (Kunshan)Co., Ltd.

Document Title	M190MWW4 R1 Module Product Specification			Page No.	4/30
Document No.		Issue date	2010/10/09	Revision	V00

### 1.0 GENERAL DESCRIPTIONS

#### 1.1 Introduction

The **M190MWW4** is a color active matrix thin film transistor (TFT) liquid crystal display (LCD) that uses amorphous silicon TFT as a switching device. It is composed of a TFT LCD panel, a timing controller, voltage reference, common voltage, driver DC-DC converter, column driver, and row driver circuit. This TFT LCD has a 19-inch diagonally measured active display area with WXGA+ resolution (1440 vertical by 900 horizontal pixel array).

#### 1.2 Features

- 19" WXGA+ TFT LCD Panel
- 2 CCFLs Backlight System
- Supported WXGA+ (V:1440 lines, H:900 pixels) resolution
- Compatible with RoHS Standard

#### 1.3 Product Summary

Items	Specifications	Unit	Remark
Screen Diagonal	18.95	inch	
Active Area	408.24 (H) x 255.15 (V) (Typ.)	mm	
Pixels H x V	1,440(x3) x900	-	
Pixel Pitch	0.2835(H)x0.2835(V)	mm	
Pixel Arrangement	R.G.B. Vertical Stripe	-	
Display Mode	TN Mode, Normally White	-	
White Luminance	200 (Typ.)	cd/ m <sup>2</sup>	(CCFL@7.5mA)
Contrast Ratio	700 : 1 typical	-	
Response Time	5 (Typ.)	ms	
View Angle(L/R/U/D)	(45/45/20/40) Typ.	-	
Input Voltage	+5 (Typ.)	V	
Power Consumption	(15.5W )	Watt	Black pattern
Module Weight	(2260) Max	g	
Outline Dimension	428.0(W)X278.0(H)X10.3(D) (Typ.)	mm	
Electrical Interface (Logic)	LVDS	-	
Support Color	16.7M	-	
NTSC	72 (Typ.)	%	
Optimum Viewing Direction	6 o'clock	-	
Surface Treatment	AG-3H	-	



## InfoVision Optoelectronics (Kunshan)Co., Ltd.

Document Title	M190MWW4 R1 Module Product Specification			Page No.	5/30
Document No.		Issue date	2010/10/09	Revision	V00

### 1.4 Functional Block Diagram

Figure 1 shows the functional block diagram of the LCD module.

Figure 1 Block Diagram

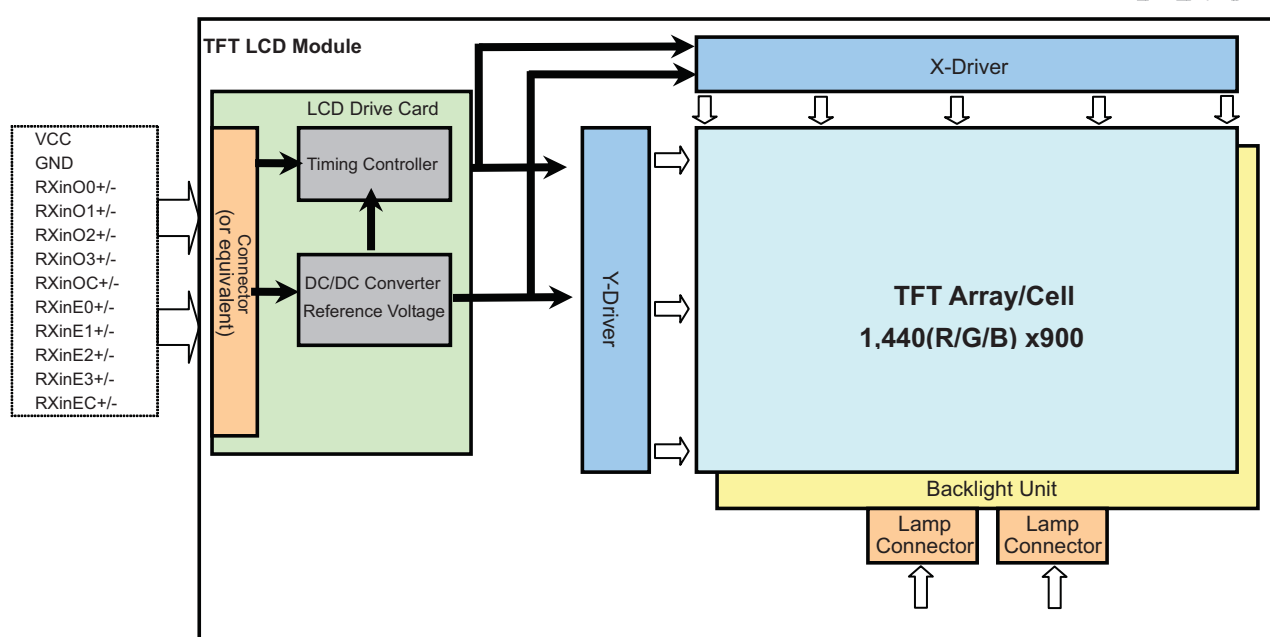



## InfoVision Optoelectronics (Kunshan)Co., Ltd.

Document Title	M190MWW4 R1 Module Product Specification			Page No.	6/30
Document No.		Issue date	2010/10/09	Revision	V00

### 2.0 Absolute Maximum Ratings

Item	Symbol	Min	Max	Unit	Conditions
Supply Voltage	VDD	-0.3	+6.0	V	
Input Signal		-0.3	+2.7	V	LVDS signals
Operating Temperature	TOP	0	+50	Deg. C	(Note)
Operating Humidity	HOP	10	80	%RH	(Note)
Storage Temperature	TST	-20	+60	Deg. C	(Note)
Storage Humidity	HST	10	90	%RH	(Note)
Vibration			1.5 10~500Hz	G Hz	30min for X, Y, Z axis
Shock			50 11	G Ms	Half sign wave
CCFL Current	I <sub>CCFL</sub>	-	(7.5)	mA	Per CCFL

Note (1)Storage /Operating temperature. Maximum Wet-Bulb should be 39 degree C.  
No condensation.

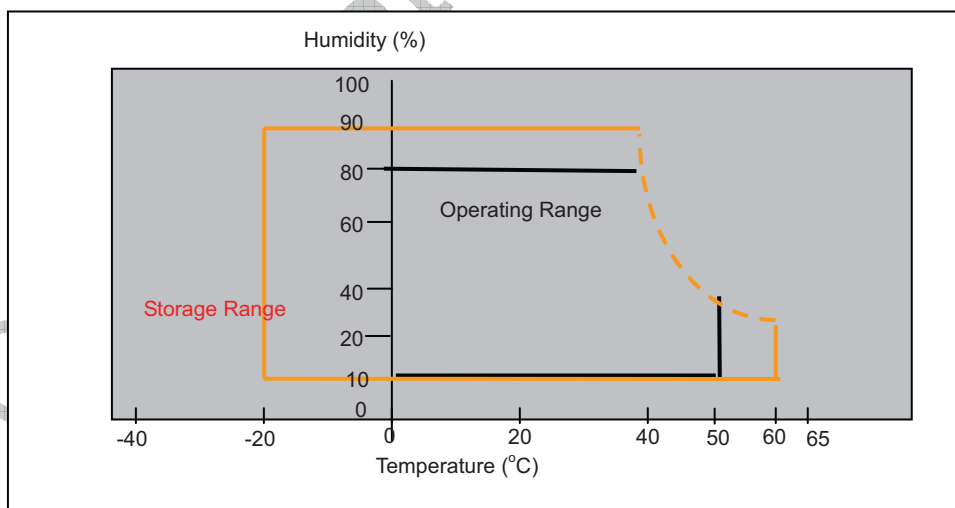



**InfoVision Optoelectronics (Kunshan)Co., Ltd.**

Document Title	M190MWW4 R1 Module Product Specification			Page No.	7/30
Document No.		Issue date	2010/10/09	Revision	V00

**3.0 Pixel Format Image**

Figure 2 shows the relationship of the input signals and LCD pixel format image.

Figure 2 Pixel Format

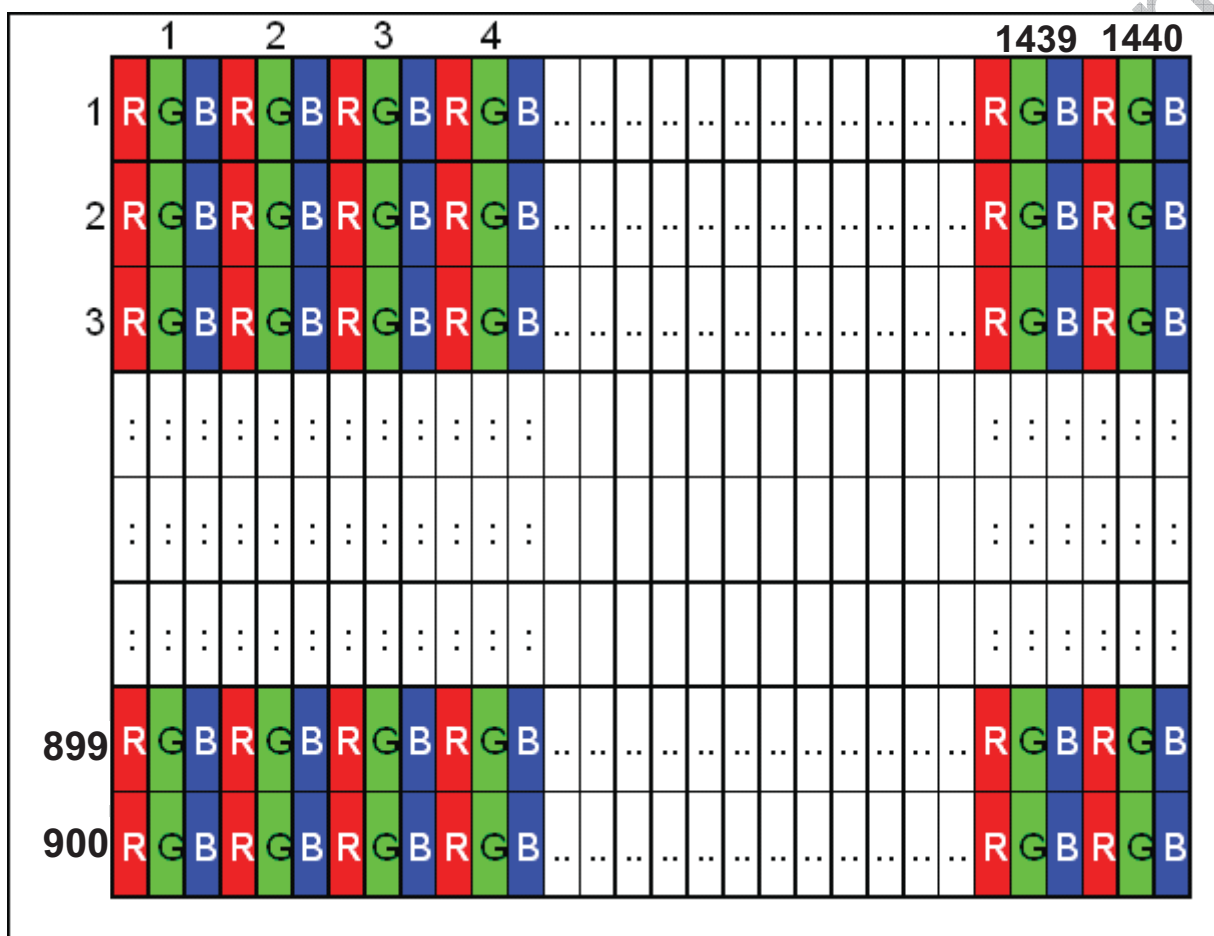



## InfoVision Optoelectronics (Kunshan)Co., Ltd.

Document Title	M190MWW4 R1 Module Product Specification			Page No.	8/30
Document No.		Issue date	2010/10/09	Revision	V00

### 4.0 Optical Characteristics

The optical characteristics are measured under stable conditions as following notes

**Table 1 Optical characteristics**

Item	Conditions	Specification			
		Min	Typ.	Max	Note
Viewing Angle [degrees] K=Contrast Ratio>10	Horizontal (Right + Left)	(80)	(90)	--	A, B
	Vertical (Up + Down)	(50)	(60)	--	
Contrast ratio		TBD	700	--	A, C
Response Time [ms]	Rising + Falling	--	5	10	A, D
Color Chromaticity (CIE1931)	Red x	-0.03	TBD	+0.03	A,
	Red y		TBD		A,
	Green x		TBD		A,
	Green y		TBD		A,
	Blue x		TBD		A,
	Blue y		TBD		A,
	White x		0.313		A,
	White y		0.329		A,
White Luminance [cd/m <sup>2</sup> ]	ICCFL=7.5mA	(170)	200	--	Center A, E
Luminance Uniformity[%]	ICCFL=7.5mA, 9points	75	80	--	A, F

Note:

#### A. Measurement Setup:

The LCD module should be stabilized at given temperature for 20 minutes to avoid abrupt temperature change during measuring. In order to stabilize the luminance, the measurement should be executed after lighting backlight for 20 minutes in a windless room.

**Figure 3 Measurement Setup**

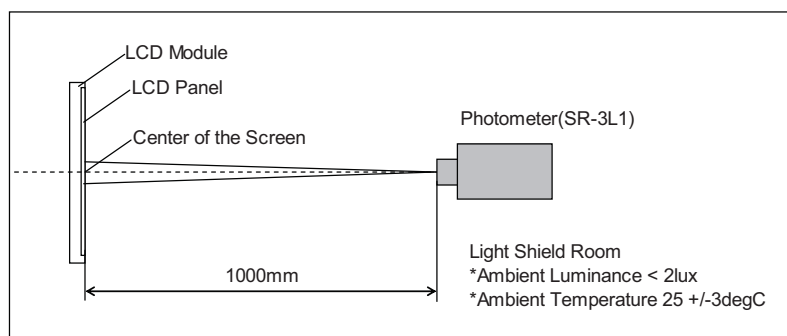





## InfoVision Optoelectronics (Kunshan)Co., Ltd.

Document Title	M190MWW4 R1 Module Product Specification			Page No.	9/30
Document No.		Issue date	2010/10/09	Revision	V00

### B. Definition of Viewing Angle

**Figure 4 Definition of Viewing Angle**

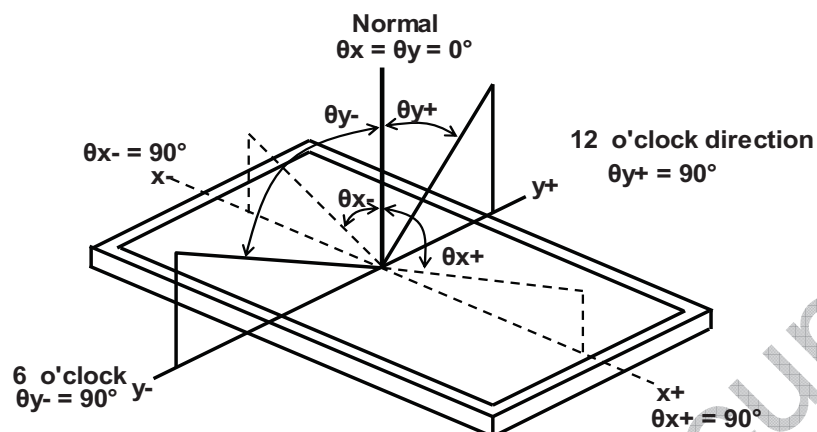

### C. Definition of Contrast Ratio (CR)

The contrast ratio can be calculated by the following expression

$$\text{Contrast Ratio (CR)} = L_{255} / L_0$$

L255: Luminance of gray level 255, L0: Luminance of gray level 0

### D. Definition of Response Time ( $T_R$ , $T_F$ )

**Figure 5 Definition of Response Time**

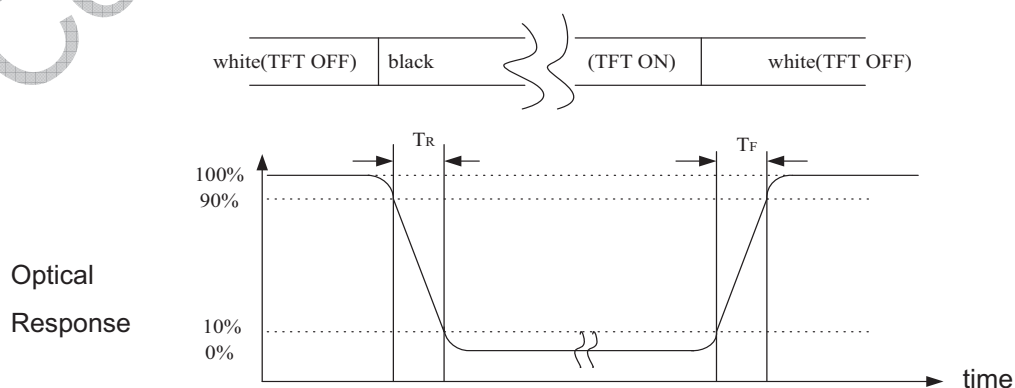



## InfoVision Optoelectronics (Kunshan)Co., Ltd.

Document Title	M190MWW4 R1 Module Product Specification			Page No.	10/30
Document No.		Issue date	2010/10/09	Revision	V00

### E. Definition of Luminance White

Measure the luminance of gray level 255 at center point

### F. Definition of Luminance Uniformity(Variation)

Measure the luminance of gray level 255 at 9 points.

$$UNF(9pts) = \frac{\min(L1, L2, \dots L9)}{\max(L1, L2, \dots L9)} \times 100\%$$

**Figure 6 Measurement Locations of 9 Points**

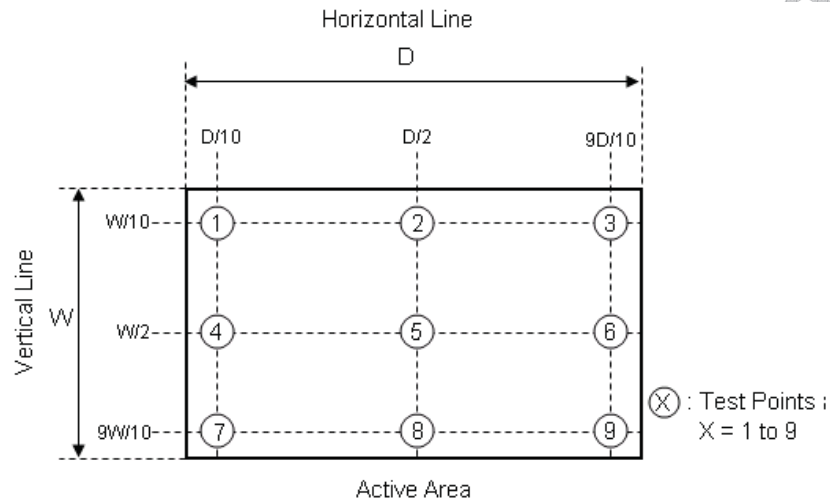

IVO Conflic



## InfoVision Optoelectronics (Kunshan)Co., Ltd.

Document Title	M190MWW4 R1 Module Product Specification			Page No.	11/30
Document No.		Issue date	2010/10/09	Revision	V00

### 5.0 Backlight Characteristics

#### 5.1 CCFL Connector

**Table 2 Connector Name / Designation**

Manufacturer	Yeonho
Type / Part Number	35001HS-02L

**Table 3 Signal assignment**

Pin #	Signal Name
1	Lamp High Voltage
2	Lamp Low Voltage

#### 5.2 Parameter Guideline for CCFL Inverter

**Table 4 Parameter guideline for CCFL Inverter**

Symbol	Parameter	Min.	Typ.	Max.	Units	Condition
$I_{CCFL}$	CCFL current	(3)	(7.5)	(8)	V	Note (1)
$F_{CCFL}$	CCFL Frequency	40	---	80	[kHz]	Ta=25[deg C] (Note 2)
$V_{CCFLi}$	Inverter Ignition Voltage	--	--	(1,700)	[Vrms]	Ta=0[deg C] (Note 3)
		--	--	(1,400)		Ta=25[deg C] (Note 3)
$V_{CCFL}$	CCFL Forward Voltage	(630)	(700)	(770)	V	ICCFL=7.5mA Ta=25[deg C]
$P_{CCFL}$	CCFL Power Consumption	-	-	(11.5)	W	-
Lamp life	CCFL	-	50,000	-	Hours	Note (4)

**Note:**

(1) If it exceeds MIN/MAX values, then "ON/OFF Cycle", and "SAFETY" will not be guaranteed.

(2) CCFL Frequency should be carefully determined to avoid interference between inverter and TFT LCD.

(3) The voltage over specified value ( $V_{CCFLi}$ ) should be applied to the lamp more than 1 second after startup. Otherwise, the lamp may not be turned on. The used lamp current is



## InfoVision Optoelectronics (Kunshan)Co., Ltd.

Document Title	M190MWW4 R1 Module Product Specification			Page No.	12/30
Document No.		Issue date	2010/10/09	Revision	V00

the lamp Typ current. The inverter should be able to give out a power that has a generating capacity of over(1,700) voltage. Lamp units need to over (1,700) voltage for ignition.

(4)  $T_a=25\pm 3\text{degC}$  and  $ICCFL=7.5\text{ mA}$ , brightness becomes lower than 50% of initial value the lamp typical current. The inverter should be able to give out a power that has a generating capacity of over 1770 voltage. Lamp units need to over 1700 voltage for ignition.

(5)The distortion tae of the waveform should be within  $\sqrt{2}\pm 10\%$

The inverter output waveform should be better similar to the ideal sine wave.

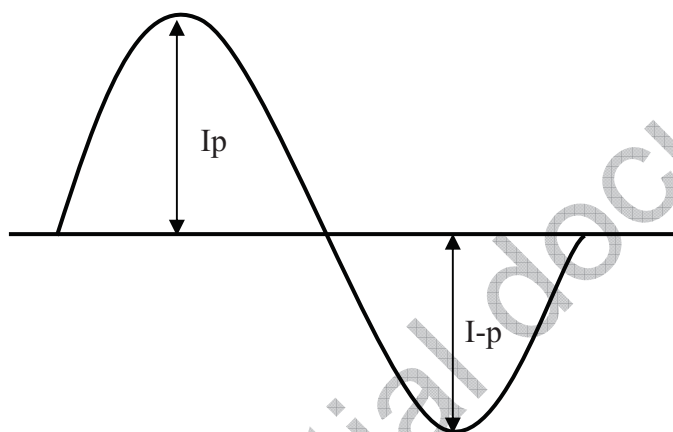

$$\text{Asymmetry rate} = |I_p - I_{-p}| / I_{rms} \times 100\%$$

$$\text{Distortion rate} = I_p \text{ (or } I_{-p}) / I_{rms}$$

**Figure 7 Recommendation of Lighting Waveform**



## InfoVision Optoelectronics (Kunshan)Co., Ltd.

Document Title	M190MWW4 R1 Module Product Specification		Page No.	13/30	
Document No.		Issue date	2010/10/09	Revision	V00

### 6.0 Electrical Characteristics

#### 6.1 Interface Connector

**Table 5 Connector Name / Designation**

Manufacturer	JAE (or equivalent)
Type / Part Number	UJU IS100-L30B-C23
Mating Receptacle/Part Number	JAE FI-X30H(L), JAE FI-X30C*(L), JAE FI-X30M*

**Table 6 Signal pin assignment**

Pin #	Signal Name	Description	Remarks
1	RXinO0-	LVDS differential data input	
2	RXinO0+	LVDS differential data input	
3	RXinO1-	LVDS differential data input	
4	RXinO1+	LVDS differential data input	
5	RXinO2-	LVDS differential data input	
6	RXinO2+	LVDS differential data input	
7	GND	Ground	
8	RXOC-	LVDS differential data input	
9	RXOC+	LVDS differential data input	
10	RXinO3-	LVDS differential data input	
11	RXinO3+	LVDS differential data input	
12	RXinE0-	LVDS differential data input	
13	RXinE0+	LVDS differential data input	
14	GND	Ground	
15	RXinE1-	LVDS differential data input	
16	RXinE1+	LVDS differential data input	
17	GND	Ground	
18	RXinE2-	LVDS differential data input	
19	RXinE2+	LVDS differential data input	
20	RXEC-	LVDS differential data input	
21	RXEC+	LVDS differential data input	
22	RXinE3-	LVDS differential data input	
23	RXinE3+	LVDS differential data input	
24	GND	Ground	
25	GND	Ground	
26	NC	Reserved for LCD manufacturer.	



## InfoVision Optoelectronics (Kunshan)Co., Ltd.

Document Title	M190MWW4 R1 Module Product Specification			Page No.	14/30
Document No.		Issue date	2010/10/09	Revision	V00

27	GND	Ground	
28	VCC	Power Supply	
29	VCC	Power Supply	
30	VCC	Power Supply	

All input signals shall be low or Hi-Z state when VDD is off.

NO Confidential document



## InfoVision Optoelectronics (Kunshan)Co., Ltd.

Document Title	M190MWW4 R1 Module Product Specification			Page No.	15/30
Document No.		Issue date	2010/10/09	Revision	V00

### 6.2 LVDS Receiver

#### 6.2.1 Signal Electrical Characteristics for LVDS Receiver

The built-in LVDS receiver is compatible with ANSI/TIA/TIA-644 standard.

**Table 7 LVDS Receiver Electrical Characteristics**

Parameter	Symbol	Min	Typ	Max	Unit	Conditions
Differential Input High Threshold	V <sub>th</sub>	--	--	+100	mV	V <sub>cm</sub> =+1.2V
Differential Input Low Threshold	V <sub>tl</sub>	-100	--	--	mV	V <sub>cm</sub> =+1.2V
Magnitude Differential Input Voltage	V <sub>id</sub>	100	--	600	mV	
Common Mode Voltage	V <sub>cm</sub>	TBD	TBD	TBD	V	
Common Mode Voltage Offset	ΔV <sub>cm</sub>	--	--	+50	mV	V <sub>cm</sub> =+1.2V

Note:

- A. Input signals shall be low or Hi-Z state when VDD is off.
- B. All electrical characteristics for LVDS signal are defined and shall be measured at the interface connector of LCD.

**Table 8 Timing Requirements**

Parameter	Symbol	Min	Typ	Max	Unit	Conditions	Note
Clock Frequency	F <sub>c</sub>	41.5	44.5	65.7	MHz		
Input Data Skew Margin	Tr <sub>skm</sub>	-850		+850	ps	F <sub>c</sub> =44.5MHz,  V <sub>th</sub> -V <sub>tl</sub>   = 400mV V <sub>cm</sub> = 1.2V, ΔV <sub>cm</sub> = 0	(Figure 11)

Note: All values are at VDD=5.0V, T<sub>a</sub>=25 degree C.



InfoVision Optoelectronics (Kunshan)Co., Ltd.

Document Title	M190MWW4 R1 Module Product Specification	Page No.	16/30
Document No.		Issue date	2010/10/09
		Revision	V00

Figure 8 Voltage Definitions

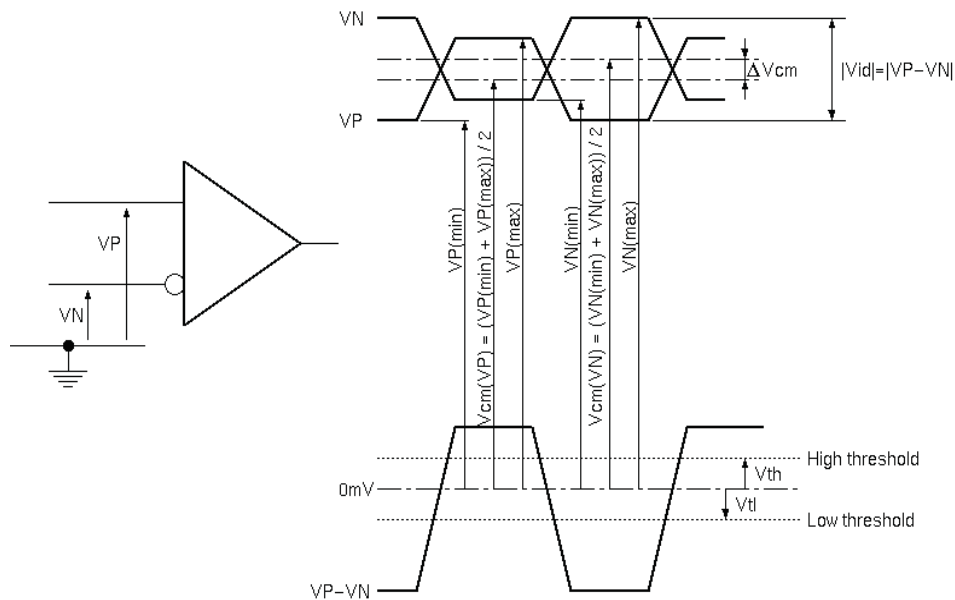
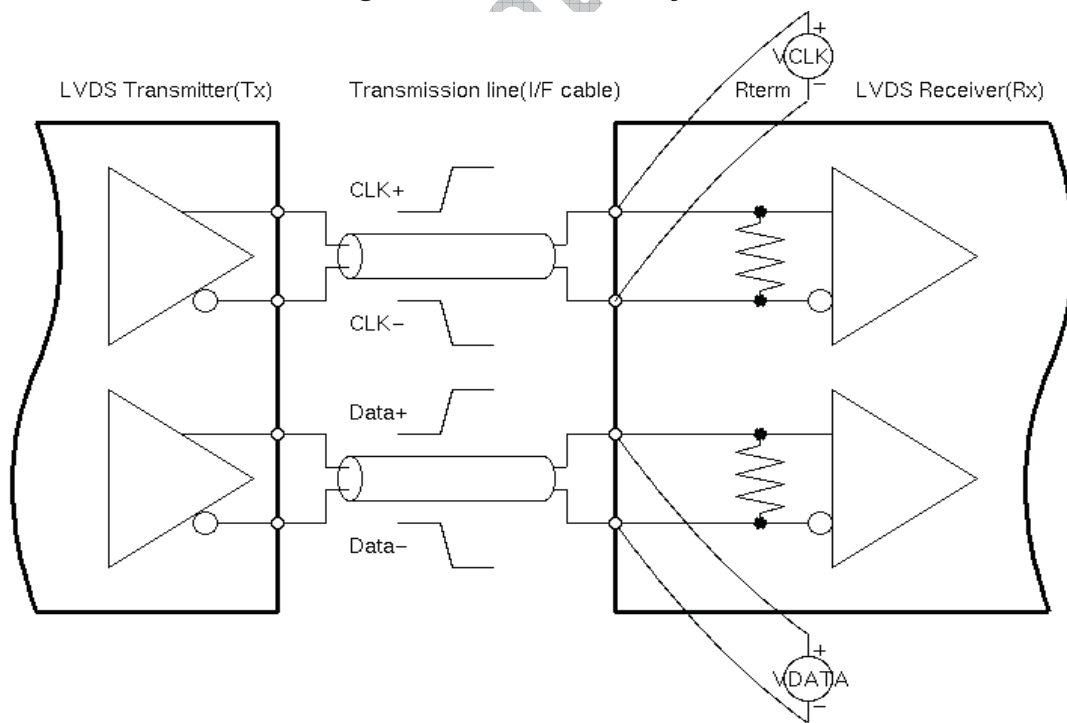

Figure 9 Measurement System







# InfoVision Optoelectronics (Kunshan)Co., Ltd.

Document Title	M190MWW4 R1 Module Product Specification			Page No.	17/30
Document No.		Issue date	2010/10/09	Revision	V00

Figure 10 Data mapping

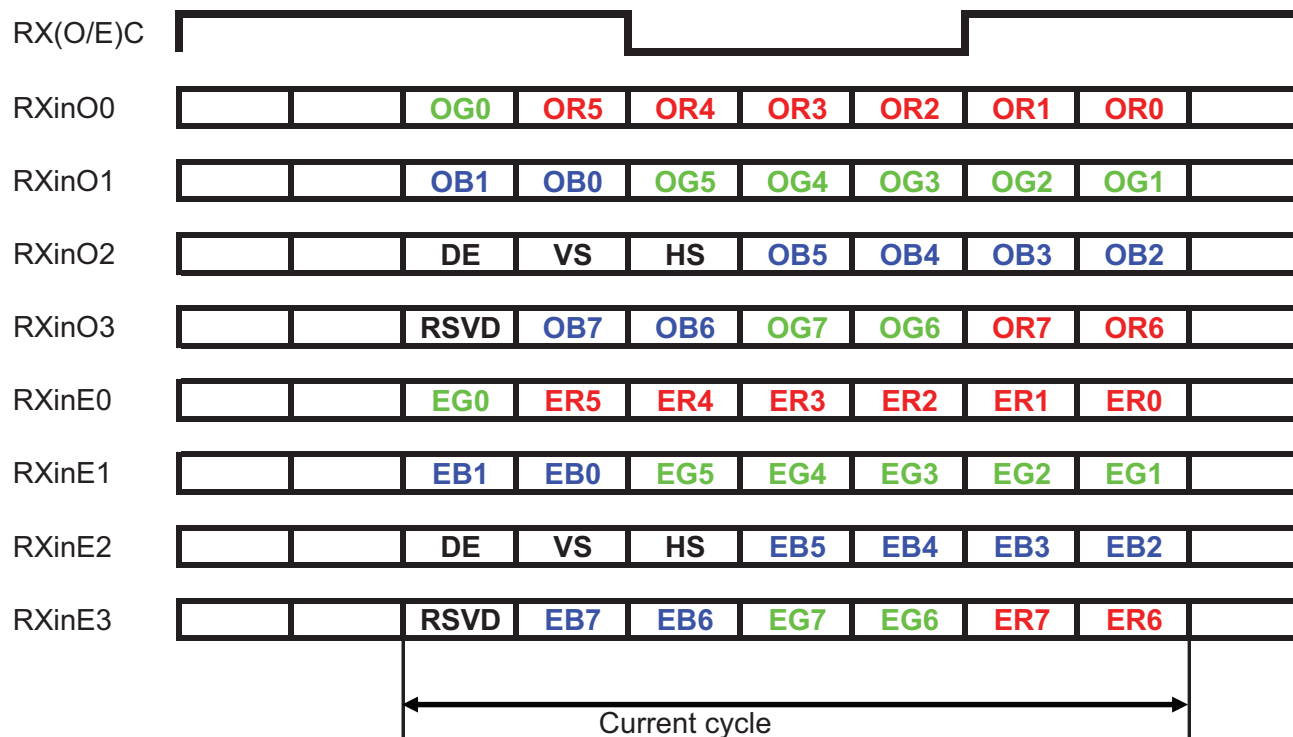



# InfoVision Optoelectronics (Kunshan)Co., Ltd.

Document Title	M190MWW4 R1 Module Product Specification	Page No.	18/30
Document No.		Issue date	2010/10/09
		Revision	V00

### Figure 11 Timing Definition

Detail A

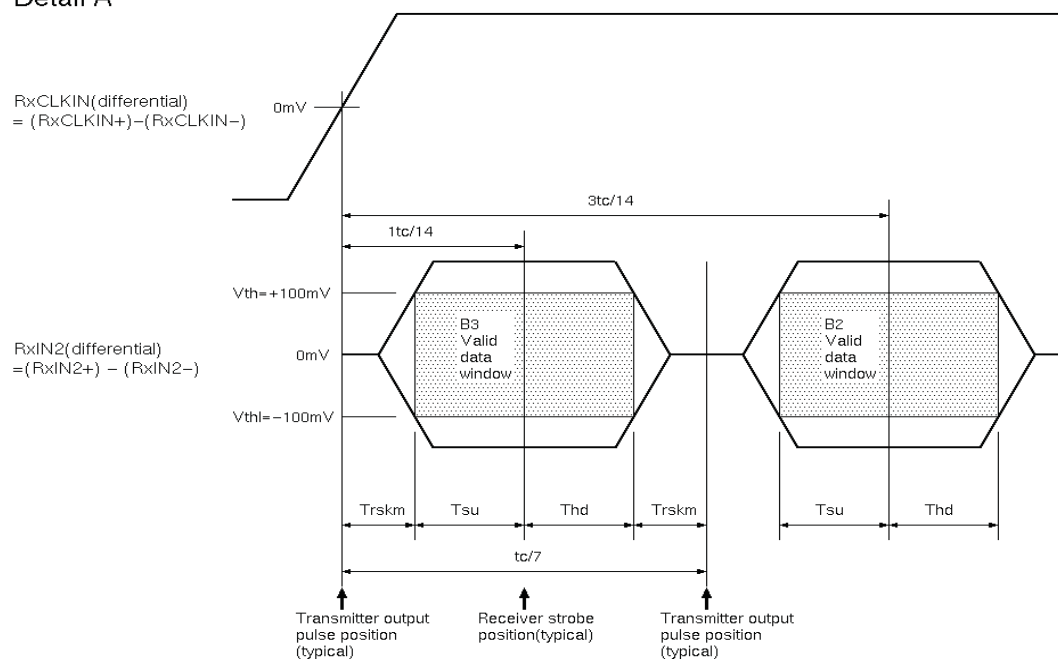

Note: Tsu and Thd is internal data sampling window of receiver. Trskm is the system skew margin; i.e., the sum of cable skew, source clock jitter, and other inter-symbol interference, shall be less than Trskm.



## InfoVision Optoelectronics (Kunshan)Co., Ltd.

Document Title	M190MWW4 R1 Module Product Specification			Page No.	19/30
Document No.		Issue date	2010/10/09	Revision	V00

### 6.2.2 LVDS Receiver Internal Circuit

Figure 12 LVDS Receiver Internal **Circuit** shows the internal block diagram of the LVDS receiver. This LCD module equips termination resistors for LVDS link.

Figure 12 LVDS Receiver Internal Circuit

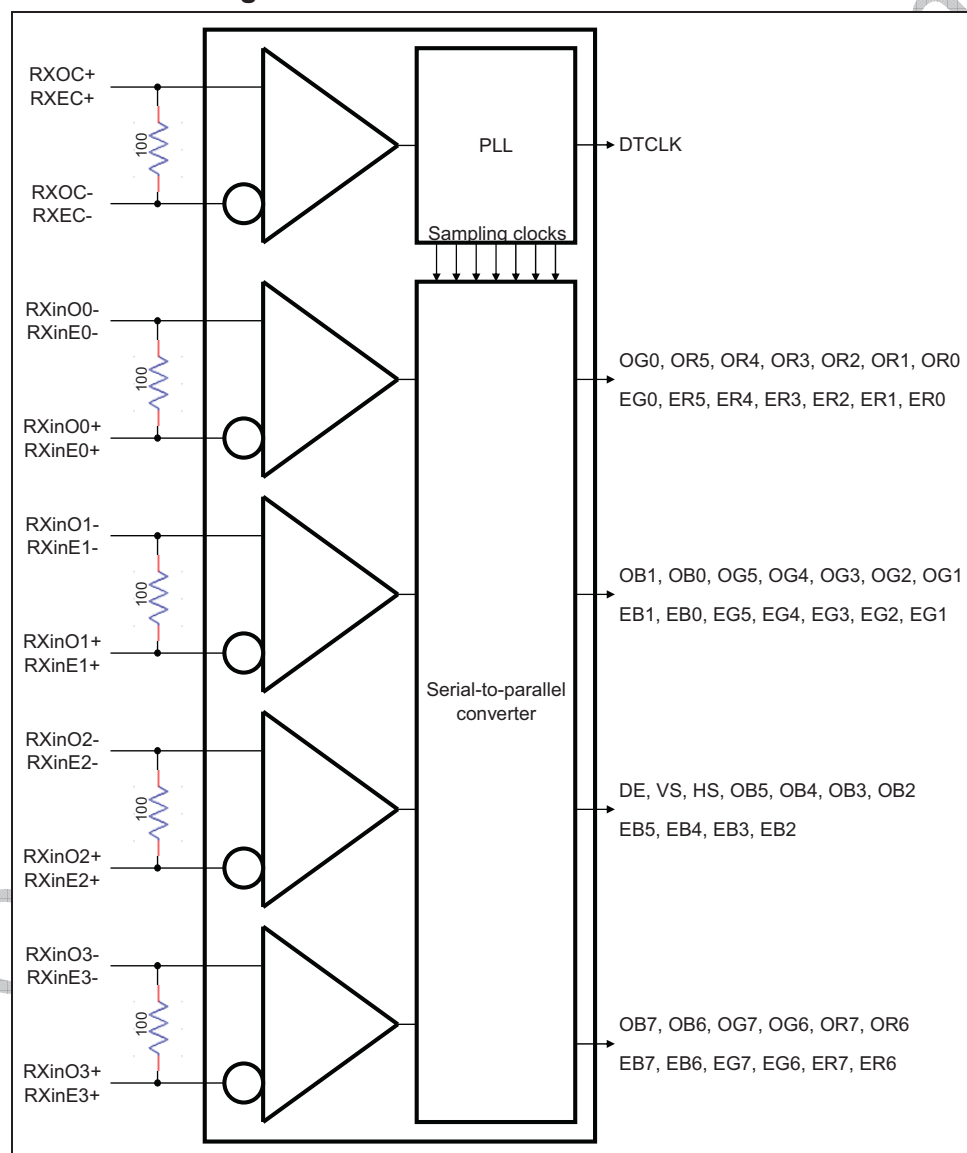



## InfoVision Optoelectronics (Kunshan)Co., Ltd.

Document Title	M190MWW4 R1 Module Product Specification			Page No.	20/30
Document No.		Issue date	2010/10/09	Revision	V00

### 7.0 Interface Timings

#### 7.1 Timing Characteristics

Table 9 Interface timings

Parameter	Symbol	Unit	Min	Typ	Max
LVDS Clock Frequency(dual)	Fdck	MHz	(41.5)	(44.5)	(65.7)
H Total Time	Htotal	clocks	(784)	(800)	(1023)
H Active Time	Hac	clocks	(720)	(720)	(720)
V Total Time	Vtotal	lines	(918)	(926)	(1400)
V Active Time	Vac	lines	(900)	(900)	(900)
Frame Rate	Vsync	Hz	(55.0)	(60.0)	(75.0)

Note (1) This product is DE only mode.

(2) Internal Vcc= 3.3V.

IVO Confidential document



# InfoVision Optoelectronics (Kunshan)Co., Ltd.

Document Title	M190MWW4 R1 Module Product Specification			Page No.	21/30
Document No.		Issue date	2010/10/09	Revision	V00

### Figure 13 Timing Characteristics

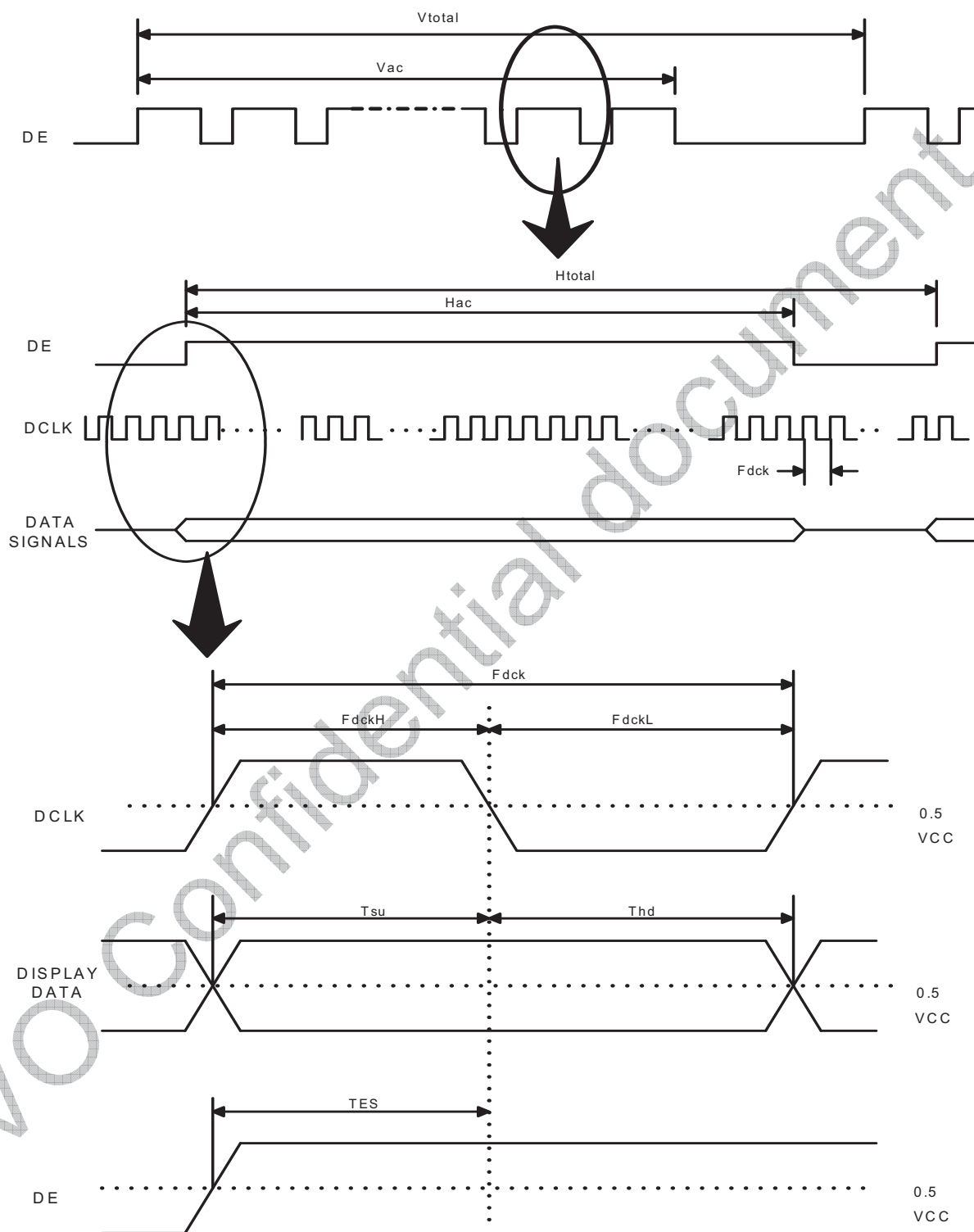

Note: TES is data enable signal setup time.



## InfoVision Optoelectronics (Kunshan)Co., Ltd.

Document Title	M190MWW4 R1 Module Product Specification			Page No.	22/30
Document No.		Issue date	2010/10/09	Revision	V00

### 8.0 Power Consumption

Input power specifications are as follows.

**Table 10 Power consumption**

SYMBOL	PARAMETER	Min	Typ	Max	UNITS	CONDITION
$V_{DD}$	Logic/LCD Drive Voltage	4.5	5.0	5.5	V	
$I_{DD}$	$V_{DD}$ Current	-	(0.6)	TBD	mA	Black Pattern, 60Hz
$P_{DD}$	$V_{DD}$ Power	-	-	(4.0)	W	Black Pattern, 60Hz
$I_{rush}$	Rush Current	-	-	3.0	A	Vdd rising time over 0.5ms. Oscilloscope Sampling over 2ms
$V_{DDrp}$	Allowable Logic/LCD Drive Ripple Voltage	-	-	300	mVp-p	-



## InfoVision Optoelectronics (Kunshan)Co., Ltd.

Document Title	M190MWW4 R1 Module Product Specification			Page No.	23/30
Document No.		Issue date	2010/10/09	Revision	V00

### 9.0 Power ON/OFF sequence

VDD power, interface signals, and lamp on/off sequence are shown in Figure 14. Signals shall be Hi-Z state or low level when VDD is off.

**Figure 14 Power sequence**

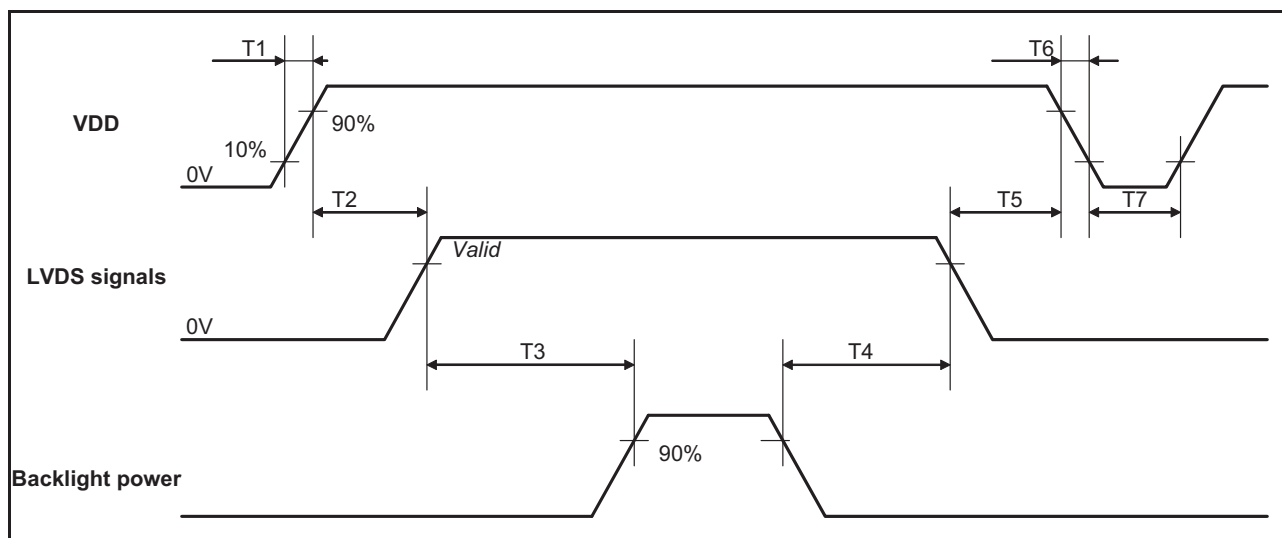

**Table 11 Power Sequencing Requirements**

Parameter	Symbol	Unit	Min	Typ	Max	Note
VDD Rise Time	T1	ms	0.5	-	10	
VDD Good to Signal Valid	T2	ms	0	-	50	
Signal Valid to Backlight On	T3	ms	200	-	-	
Backlight Off to Signal Disable	T4	ms	100	-	-	
Signal Disable to Power Down	T5	ms	0	-	50	
VDD Fall Time	T6	ms	-	-	10	
Power Off	T7	ms	TBD	-	-	

Note1: The system designed should decrease the Vdd under 2.2V within 10ms during T6 period.



InfoVision Optoelectronics (Kunshan)Co., Ltd.

Document Title	M190MWW4 R1 Module Product Specification		Page No.	24/30	
Document No.		Issue date	2010/10/09	Revision	V00

10.0 Mechanical Characteristics

Figure 15 Reference outline drawing (Front side)

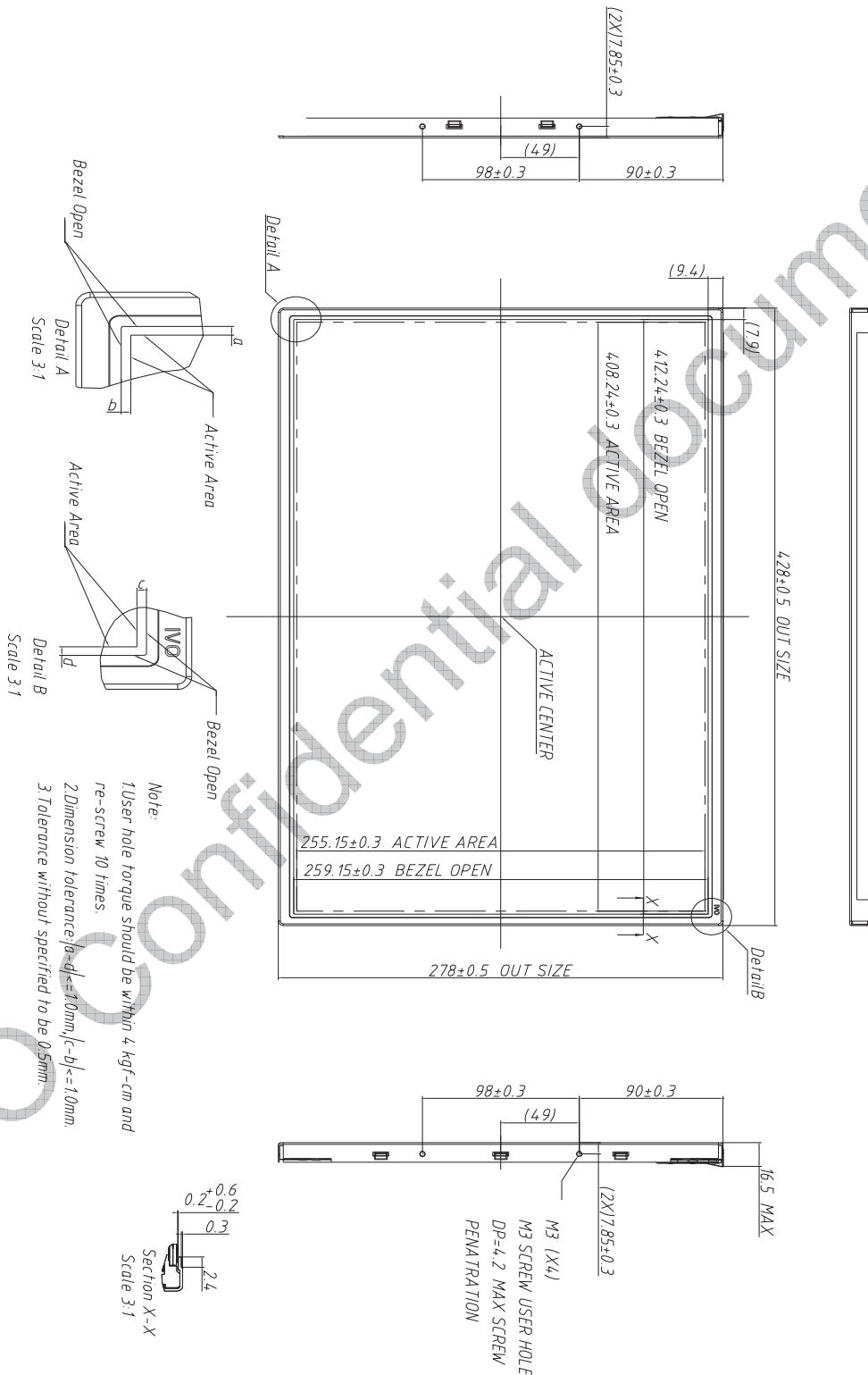





# InfoVision Optoelectronics (Kunshan)Co., Ltd.

Document Title	M190MWW4 R1 Module Product Specification		Page No.	25/30	
Document No.		Issue date	2010/10/09	Revision	V00

Figure 16 Reference outline drawing (Back side)

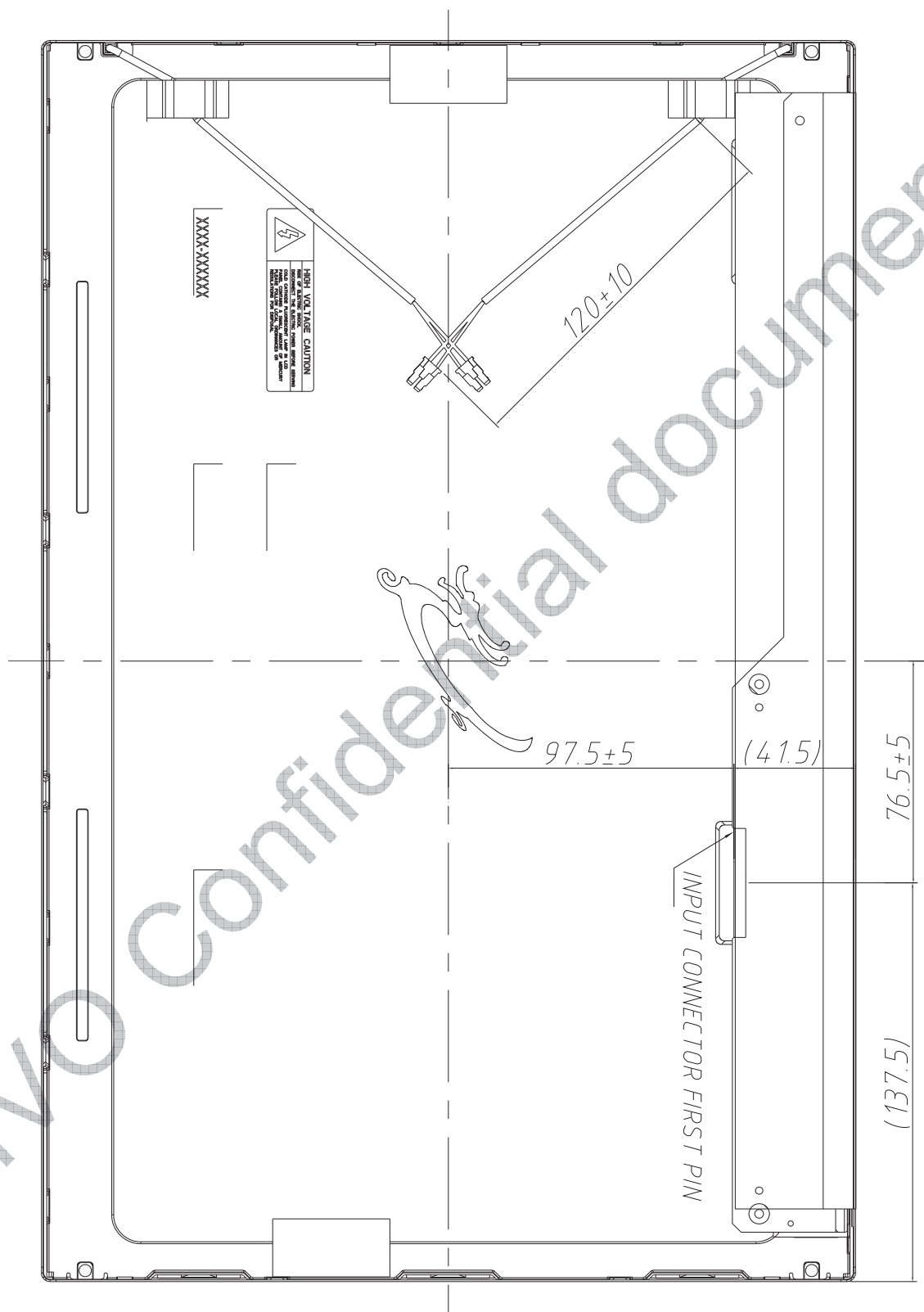



## InfoVision Optoelectronics (Kunshan)Co., Ltd.

Document Title	M190MWW4 R1 Module Product Specification			Page No.	26/30
Document No.		Issue date	2010/10/09	Revision	V00

### 10.1 Dimension Specifications

Table 12 Module Dimension Specifications

Width [mm]		428 ± 0.5
Height [mm]		278 ± 0.5
Thickness [mm]		Max 16.5
Bezel Opening [mm]	X	412.24 ± 0.3
	Y	259.15 ± 0.3
Weight [g]		2260(max)
BM :   a-b   &   c-d		≤ 1.0mm

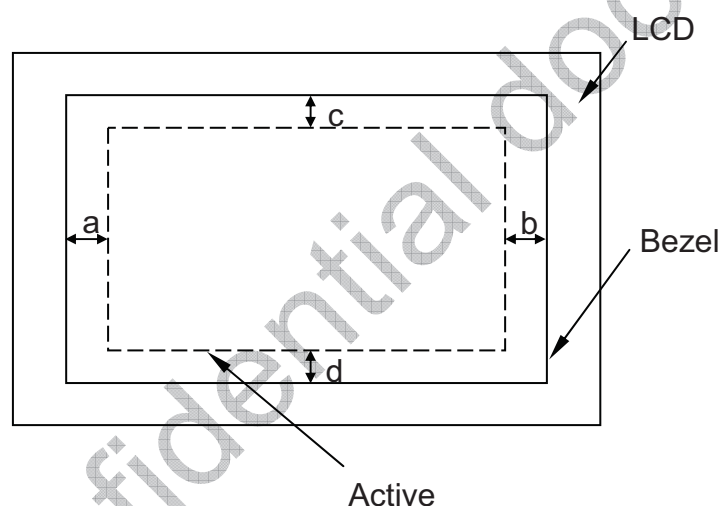



## InfoVision Optoelectronics (Kunshan)Co., Ltd.

Document Title	M190MWW4 R1 Module Product Specification		Page No.	27/30	
Document No.		Issue date	2010/10/09	Revision	V00

### 11.0 PACKAGE SPECIFICATION

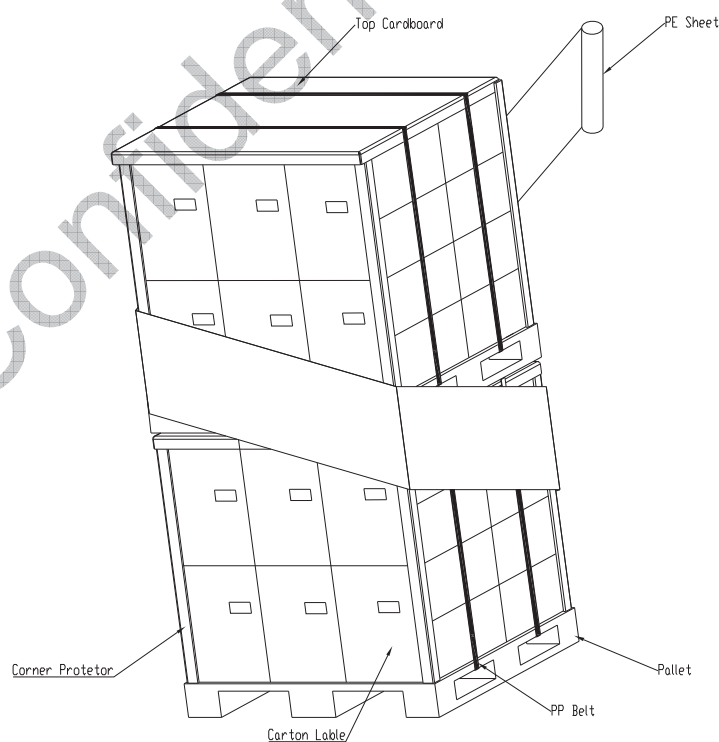
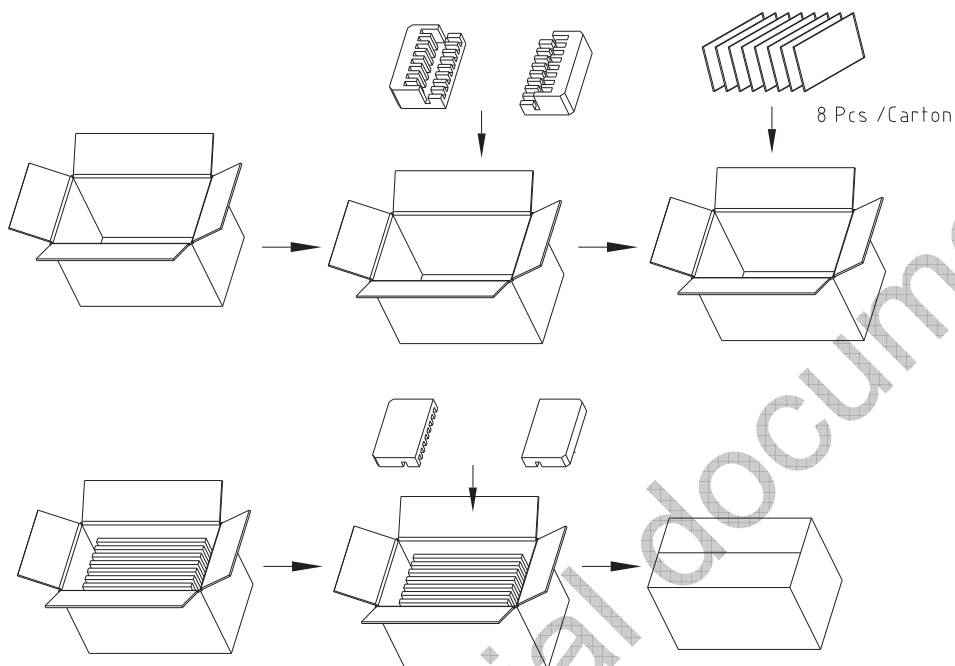



# InfoVision Optoelectronics (Kunshan)Co., Ltd.

Document Title	M190MWW4 R1 Module Product Specification			Page No.	28/30
Document No.		Issue date	2010/10/09	Revision	V00

## 12.0 LOT MARK

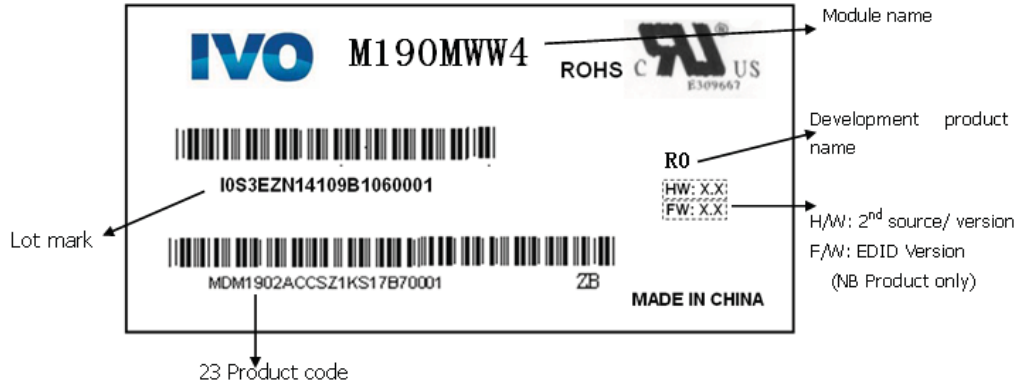

### 12.1 Lot Mark

1	2	3	4	5	6	7	8	9	10	11	12	13	14	15	16	17	18	19	20
---	---	---	---	---	---	---	---	---	----	----	----	----	----	----	----	----	----	----	----

- code 1,2,4,5,6,7,8,9,10,11,16: IVO internal flow control code.
- code 3: production location.
- code 12: production year.
- code 13: production month.
- code 14,15: production date.
- code 17,18,19,20: serial number.

#### Note (1) Production Year

Year	2006	2007	2008	2009	2010	2011	2012	2013	2014	2015
Mark	6	7	8	9	A	B	C	D	F	G

#### Note (2) Production Month

Month	Jan.	Feb.	Mar.	Apr.	May.	Jun.	Jul.	Aug.	Sep.	Oct	Nov.	Dec.
Mark	1	2	3	4	5	6	7	8	9	A	B	C

### 12.3 23 product barcode

1	2	3	4	5	6	7	8	9	10	11	12	13	14	15	16	17	18	19	20	21	22	23
---	---	---	---	---	---	---	---	---	----	----	----	----	----	----	----	----	----	----	----	----	----	----

- code 1,2: MD Mindtech Display.
- code 3,4,5,6,7: MTDIs internal module name.
- code 8,9,10,13,16: MTDIs internal flow control code.
- code 11,12: Cell location Suzhou defined as "SZ".
- code 14,15: Module line kunshan defined as "KS".
- code 17,18,19: Year, Month, Day Refer to MTDIs barcode Note(1),Note(2).
- code 20~23: Serial Number.



## InfoVision Optoelectronics (Kunshan)Co., Ltd.

Document Title	M190MWW4 R1 Module Product Specification			Page No.	29/30
Document No.		Issue date	2010/10/09	Revision	V00

### 13.0 GENERAL PRECAUTION

#### 13.1 Use Restriction

This product is not authorized for use in life supporting systems, aircraft navigation control systems, military systems and any other application where performance failure could be life-threatening or otherwise catastrophic.

#### 13.2 Disassembling or Modification

Do not disassemble or modify the module. It may damage sensitive parts inside LCD module, and may cause scratches or dust on the display. MTD does not warrant the module, if customers disassemble or modify the module.

#### 13.3 Breakage of LCD Panel

13.3.1 If LCD panel is broken and liquid crystal spills out, do not ingest or inhale liquid crystal, and do not contact liquid crystal with skin.

13.3.2 If liquid crystal contacts mouth or eyes, rinse out with water immediately.

13.3.3 If liquid crystal contacts skin or cloths, wash it off immediately with alcohol and rinse thoroughly with water.

13.3.4 Handle carefully with chips of glass that may cause injury, when the glass is broken

#### 13.4 Electric Shock

13.4.1 Disconnect power supply before handling LCD module.

13.4.2 Do not pull or fold the CCFL cable.

13.4.3 Do not touch the parts inside LCD modules and the fluorescent lamp's connector Or cables in order to prevent electric shock

#### 13.5 Absolute Maximum Ratings and Power Protection Circuit

13.5.1 Do not exceed the absolute maximum rating values, such as the supply voltage variation, input voltage variation, variation in parts' parameters, environmental temperature; etc otherwise LCD module may be damaged.

13.5.2 Please do not leave LCD module in the environment of high humidity and high temperature for a long time.

13.5.3 It's recommended employing protection circuit for power supply.

#### 13.6 Operation

13.6.1 Do not touch, push or rub the polarizer with anything harder than HB pencil lead. Use fingerstalls of soft gloves in order to keep clean display quality, when persons handle the LCD module for incoming inspection or assembly.

13.6.2 When the surface is dusty, please wipe gently with absorbent cotton or other soft material

13.6.3 Wipe off saliva or water drops as soon as possible. If saliva or water drops contact with polarizer for a long time, they may causes deformation or color fading

13.6.4 When cleaning the adhesives, please use absorbent cotton wetted with a little petroleum benzene or other adequate solvent

#### 13.7 Mechanism

Please mount LCD module by using mounting holes arranged in four corners tightly.

#### 13.8 Static Electricity

13.8.1 Protection film must remove very slowly from the surface of LCD module to



## InfoVision Optoelectronics (Kunshan)Co., Ltd.

Document Title	M190MWW4 R1 Module Product Specification		Page No.	30/30
Document No.		Issue date	2010/10/09	Revision V00

prevent from electrostatic occurrence.

13.8.2 Because LCD module uses CMOS-IC on circuit board and TFT-LCD panel, it is very weak to electrostatic discharge, Please be careful with electrostatic discharge

13.8.3 Persons who handle the module should be grounded through adequate methods.

### 13.9 Strong Light Exposure

The module shall not be exposed under strong light such as direct sunlight. Otherwise, display characteristics may be changed.

### 13.10 Disposal

When disposing LCD module, obey the local environmental regulations.

IVO Confidential document