



() Preliminary Specification
(V) Final Specification

Module	19"W Color TFT-LCD
Model Name	M190PW01 V8 (ES7.0 from V80K)

Customer	Date
_____	_____
Approved by	
_____	_____

Approved by	Date
<u>Howard Lee</u>	<u>Jan.21, 2016</u>
Prepared by	Date
<u>Amy Wu</u>	<u>Jan. 21, 2016</u>

Note: This Specification is subject to change without notice.

AU Optronics corporation

Contents

1 Handling Precautions.....	5
2 General Description	6
2.1 Display Characteristics.....	6
2.2 Absolute Maximum Rating of Environment	7
2.3 Optical Characteristics	8
2.4 Mechanical Characteristics (For TPV ONLY).....	12
3 TFT-LCD Module.....	13
3.1 Block Diagram.....	13
3.2 Interface Connection.....	14
3.2.1 Connector Type.....	14
3.2.2 Connector Pin Assignment.....	14
3.3 Electrical Characteristics.....	16
3.3.1 Absolute Maximum Rating	16
3.3.2 Recommended Operating Condition.....	16
3.4 Signal Characteristics	17
3.4.1 LCD Pixel Format.....	17
3.4.2 LVDS Data Format.....	17
3.4.3 Color versus Input Data	18
3.4.4 LVDS Specification.....	19
3.4.5 Input Timing Specification	21
3.4.6 Input Timing Diagram.....	22
3.5 Power ON/OFF Sequence	23
4 Backlight Unit.....	24
4.1 Block Diagram.....	24
4.2 Interface Connection.....	25
4.2.1 Connector Type.....	25
4.2.2 Connector Pin Assignment.....	27
4.3 Electrical Characteristics.....	28
4.3.1 Absolute Maximum Rating	28
4.3.2 Recommended Operating Condition.....	28
5 Reliability Test.....	30
6 Shipping Label	31
7 Mechanical Characteristics.....	32
8 Packing Specification.....	33
8.1 Packing Flow.....	33
8.2 Pallet and shipment information.....	34

Record of Revision

Version	Date	Page	Old description	New Description	Remark																																																																																																																																																																																																				
1.0	2014/3/3	All	First version release	-																																																																																																																																																																																																					
1.1	2014/3/13	20	3.4.5 Input Timing specification <table border="1"> <thead> <tr> <th>Symbol</th> <th>Description</th> <th>Min.</th> <th>Typ.</th> <th>Max.</th> <th>Unit</th> <th>Remark</th> </tr> </thead> <tbody> <tr> <td>I_{V+}</td> <td rowspan="3">Vertical Section</td> <td>Period</td> <td>912</td> <td>916</td> <td>1661</td> <td>11μs</td> </tr> <tr> <td>$I_{d52}(V+)$</td> <td>Active</td> <td>900</td> <td>900</td> <td>900</td> <td>11μs</td> </tr> <tr> <td>$T_{blk}(V+)$</td> <td>Blanking</td> <td>12</td> <td>16</td> <td>781</td> <td>11μs</td> </tr> <tr> <td>F_{V+}</td> <td rowspan="3">Horizontal Section</td> <td>Frequency</td> <td>813</td> <td>964</td> <td>1472</td> <td>Hz</td> </tr> <tr> <td>T_{H+}</td> <td>Period</td> <td>720</td> <td>720</td> <td>720</td> <td>10μs</td> </tr> <tr> <td>$I_{d52}(H+)$</td> <td>Active</td> <td>35</td> <td>244</td> <td>762</td> <td>10μs</td> </tr> <tr> <td>$T_{blk}(H+)$</td> <td rowspan="3">LVDS Clock</td> <td>Blanking</td> <td>11.9</td> <td>18.9</td> <td>27.0</td> <td>10μs</td> </tr> <tr> <td>F_{H+}</td> <td>Frequency</td> <td>37.1</td> <td>53.0</td> <td>87.1</td> <td>KHz</td> </tr> <tr> <td>T_{clk}</td> <td>Period</td> <td>40</td> <td>m</td> <td>76</td> <td>nS</td> </tr> <tr> <td>E_{clk}</td> <td>Frequency</td> <td>45.6</td> <td>55.0</td> <td>82.5</td> <td>MHz</td> </tr> </tbody> </table>	Symbol	Description	Min.	Typ.	Max.	Unit	Remark	I_{V+}	Vertical Section	Period	912	916	1661	11 μ s	$I_{d52}(V+)$	Active	900	900	900	11 μ s	$T_{blk}(V+)$	Blanking	12	16	781	11 μ s	F_{V+}	Horizontal Section	Frequency	813	964	1472	Hz	T_{H+}	Period	720	720	720	10 μ s	$I_{d52}(H+)$	Active	35	244	762	10 μ s	$T_{blk}(H+)$	LVDS Clock	Blanking	11.9	18.9	27.0	10 μ s	F_{H+}	Frequency	37.1	53.0	87.1	KHz	T_{clk}	Period	40	m	76	nS	E_{clk}	Frequency	45.6	55.0	82.5	MHz	3.4.5 Input Timing specification <table border="1"> <thead> <tr> <th>Symbol</th> <th>Description</th> <th>Min.</th> <th>Typ.</th> <th>Max.</th> <th>Unit</th> <th>Remark</th> </tr> </thead> <tbody> <tr> <td>I_{V+}</td> <td rowspan="3">Vertical Section</td> <td>Period</td> <td>914</td> <td>916</td> <td>1801</td> <td>11μs</td> </tr> <tr> <td>$I_{d52}(V+)$</td> <td>Active</td> <td>900</td> <td>900</td> <td>900</td> <td>11μs</td> </tr> <tr> <td>$T_{blk}(V+)$</td> <td>Blanking</td> <td>14</td> <td>6</td> <td>501</td> <td>11μs</td> </tr> <tr> <td>F_{V+}</td> <td rowspan="3">Horizontal Section</td> <td>Frequency</td> <td>49</td> <td>60</td> <td>76</td> <td>Hz</td> </tr> <tr> <td>T_{H+}</td> <td>Period</td> <td>780</td> <td>904</td> <td>1408</td> <td>10μs</td> </tr> <tr> <td>$I_{d52}(H+)$</td> <td>Active</td> <td>720</td> <td>720</td> <td>720</td> <td>10μs</td> </tr> <tr> <td>$T_{blk}(H+)$</td> <td rowspan="3">LVDS Clock</td> <td>Blanking</td> <td>40</td> <td>244</td> <td>778</td> <td>10μs</td> </tr> <tr> <td>F_{H+}</td> <td>Frequency</td> <td>44.9</td> <td>56.3</td> <td>88.2</td> <td>KHz</td> </tr> <tr> <td>T_{clk}</td> <td>Period</td> <td>15.0</td> <td>10.3</td> <td>29.3</td> <td>nS</td> </tr> <tr> <td>E_{clk}</td> <td>Frequency</td> <td>34</td> <td>63.3</td> <td>67.1</td> <td>MHz</td> </tr> </tbody> </table>	Symbol	Description	Min.	Typ.	Max.	Unit	Remark	I_{V+}	Vertical Section	Period	914	916	1801	11 μ s	$I_{d52}(V+)$	Active	900	900	900	11 μ s	$T_{blk}(V+)$	Blanking	14	6	501	11 μ s	F_{V+}	Horizontal Section	Frequency	49	60	76	Hz	T_{H+}	Period	780	904	1408	10 μ s	$I_{d52}(H+)$	Active	720	720	720	10 μ s	$T_{blk}(H+)$	LVDS Clock	Blanking	40	244	778	10 μ s	F_{H+}	Frequency	44.9	56.3	88.2	KHz	T_{clk}	Period	15.0	10.3	29.3	nS	E_{clk}	Frequency	34	63.3	67.1	MHz																																																									
Symbol	Description	Min.	Typ.	Max.	Unit	Remark																																																																																																																																																																																																			
I_{V+}	Vertical Section	Period	912	916	1661	11 μ s																																																																																																																																																																																																			
$I_{d52}(V+)$		Active	900	900	900	11 μ s																																																																																																																																																																																																			
$T_{blk}(V+)$		Blanking	12	16	781	11 μ s																																																																																																																																																																																																			
F_{V+}	Horizontal Section	Frequency	813	964	1472	Hz																																																																																																																																																																																																			
T_{H+}		Period	720	720	720	10 μ s																																																																																																																																																																																																			
$I_{d52}(H+)$		Active	35	244	762	10 μ s																																																																																																																																																																																																			
$T_{blk}(H+)$	LVDS Clock	Blanking	11.9	18.9	27.0	10 μ s																																																																																																																																																																																																			
F_{H+}		Frequency	37.1	53.0	87.1	KHz																																																																																																																																																																																																			
T_{clk}		Period	40	m	76	nS																																																																																																																																																																																																			
E_{clk}	Frequency	45.6	55.0	82.5	MHz																																																																																																																																																																																																				
Symbol	Description	Min.	Typ.	Max.	Unit	Remark																																																																																																																																																																																																			
I_{V+}	Vertical Section	Period	914	916	1801	11 μ s																																																																																																																																																																																																			
$I_{d52}(V+)$		Active	900	900	900	11 μ s																																																																																																																																																																																																			
$T_{blk}(V+)$		Blanking	14	6	501	11 μ s																																																																																																																																																																																																			
F_{V+}	Horizontal Section	Frequency	49	60	76	Hz																																																																																																																																																																																																			
T_{H+}		Period	780	904	1408	10 μ s																																																																																																																																																																																																			
$I_{d52}(H+)$		Active	720	720	720	10 μ s																																																																																																																																																																																																			
$T_{blk}(H+)$	LVDS Clock	Blanking	40	244	778	10 μ s																																																																																																																																																																																																			
F_{H+}		Frequency	44.9	56.3	88.2	KHz																																																																																																																																																																																																			
T_{clk}		Period	15.0	10.3	29.3	nS																																																																																																																																																																																																			
E_{clk}	Frequency	34	63.3	67.1	MHz																																																																																																																																																																																																				
1.2	2014/4/28	13 31	TFT-LCD Connector Manufacturer Name: CHIEF 7 Mechanical Characteristics – no user hold 2D drawing	TFT-LCD Connector Manufacturer Name: STARCONN 7 Mechanical Characteristics – add user hold 2D drawing																																																																																																																																																																																																					
1.3	2015/10/2	5 7 27 28	2.1 Display Characteristics - Power Consumption (LCD Module+ Backligh unit) = 10.4 (Typ.) Watt LCD module : PDD (Typ.)= 2.0 @ Black pattern,Fv=60Hz Backlight unit : P _{BLU} (Typ.) =8.4@Is=60mA TCO 6.0 Compliance 2.3 Optical Characteristics - Test Condition: 3. VDD=5.0V, Fv=60Hz,Is=60mA,Ta=25 \square <table border="1"> <thead> <tr> <th>Symbol</th> <th>Description</th> <th>Min.</th> <th>Typ.</th> <th>Max.</th> <th>Unit</th> <th>Remark</th> </tr> </thead> <tbody> <tr> <td>R_{x1}</td> <td rowspan="12">Color Coordinates (CIE 1931)</td> <td>Red x¹</td> <td>0.615</td> <td>0.645</td> <td>0.675</td> <td rowspan="12">By SR-3</td> </tr> <tr> <td>R_{y1}</td> <td>Red y¹</td> <td>0.314</td> <td>0.344</td> <td>0.374</td> </tr> <tr> <td>G_{x1}</td> <td>Green x¹</td> <td>0.292</td> <td>0.322</td> <td>0.352</td> </tr> <tr> <td>G_{y1}</td> <td>Green y¹</td> <td>0.604</td> <td>0.634</td> <td>0.664</td> </tr> <tr> <td>B_{x1}</td> <td>Blue x¹</td> <td>0.124</td> <td>0.154</td> <td>0.184</td> </tr> <tr> <td>B_{y1}</td> <td>Blue y¹</td> <td>0.020</td> <td>0.050</td> <td>0.080</td> </tr> <tr> <td>W_{x1}</td> <td>White x¹</td> <td>0.283</td> <td>0.313</td> <td>0.343</td> </tr> <tr> <td>W_{y1}</td> <td>White y¹</td> <td>0.299</td> <td>0.329</td> <td>0.359</td> </tr> </tbody> </table> 4.3.2 Recommended Operating Condition <table border="1"> <thead> <tr> <th>Symbol</th> <th>Description</th> <th>Min.</th> <th>Typ.</th> <th>Max.</th> <th>Unit</th> <th>Remark</th> </tr> </thead> <tbody> <tr> <td>I_{s1}</td> <td>LED String Current</td> <td>-</td> <td>60</td> <td>60</td> <td>[mA]</td> <td>100% duty ratio of LED chip</td> </tr> <tr> <td>V_{s1}</td> <td>LED String Voltage</td> <td>30.8</td> <td>35.2</td> <td>36.6</td> <td>[VDC]</td> <td>Is=60mA @ 100% duty ratio. Note 4-1, Note 4-5</td> </tr> <tr> <td>ΔV_{s1}</td> <td>Maximum Vs Voltage Deviation of light bar</td> <td>-</td> <td>2.2</td> <td>-</td> <td>[VDC]</td> <td>Is=60mA @ 100% duty ratio. Note 4-2</td> </tr> <tr> <td>P_{BLU1}</td> <td>LED Light Bar Power Consumption</td> <td>-</td> <td>8.4</td> <td>9.5</td> <td>[Watt]</td> <td>Note 4-3</td> </tr> <tr> <td>$L_{T,LED1}$</td> <td>LED Life Time</td> <td>30,000</td> <td>-</td> <td>-</td> <td>[Hour]</td> <td>Note 4-4</td> </tr> <tr> <td>OV_{P1}</td> <td>Over Voltage Protection in system board</td> <td>110%</td> <td>-</td> <td>-</td> <td>[VOLT]</td> <td>Note 4-5</td> </tr> </tbody> </table>	Symbol	Description	Min.	Typ.	Max.	Unit	Remark	R_{x1}	Color Coordinates (CIE 1931)	Red x ¹	0.615	0.645	0.675	By SR-3	R_{y1}	Red y ¹	0.314	0.344	0.374	G_{x1}	Green x ¹	0.292	0.322	0.352	G_{y1}	Green y ¹	0.604	0.634	0.664	B_{x1}	Blue x ¹	0.124	0.154	0.184	B_{y1}	Blue y ¹	0.020	0.050	0.080	W_{x1}	White x ¹	0.283	0.313	0.343	W_{y1}	White y ¹	0.299	0.329	0.359	Symbol	Description	Min.	Typ.	Max.	Unit	Remark	I_{s1}	LED String Current	-	60	60	[mA]	100% duty ratio of LED chip	V_{s1}	LED String Voltage	30.8	35.2	36.6	[VDC]	Is=60mA @ 100% duty ratio. Note 4-1, Note 4-5	ΔV_{s1}	Maximum Vs Voltage Deviation of light bar	-	2.2	-	[VDC]	Is=60mA @ 100% duty ratio. Note 4-2	P_{BLU1}	LED Light Bar Power Consumption	-	8.4	9.5	[Watt]	Note 4-3	$L_{T,LED1}$	LED Life Time	30,000	-	-	[Hour]	Note 4-4	OV_{P1}	Over Voltage Protection in system board	110%	-	-	[VOLT]	Note 4-5	2.1 Display Characteristics - Power Consumption (LCD Module+ Backligh unit) = 9.0 (Typ.) LCD module : PDD (Typ.)= 2.0 @ Black pattern,Fv=60Hz Backlight unit : P _{BLU} (Typ.) =7.0@Is=50mA TCO 7.0 Compliance 2.3 Optical Characteristics - Test Condition: 3. VDD=5.0V, Fv=60Hz,Is=50mA,Ta=25 \square <table border="1"> <thead> <tr> <th>Symbol</th> <th>Description</th> <th>Min.</th> <th>Typ.</th> <th>Max.</th> <th>Unit</th> <th>Remark</th> </tr> </thead> <tbody> <tr> <td>R_{x1}</td> <td rowspan="12">Color Coordinates (CIE 1931)</td> <td>Red x¹</td> <td>0.609</td> <td>0.639</td> <td>0.669</td> <td rowspan="12">By SR-3</td> </tr> <tr> <td>R_{y1}</td> <td>Red y¹</td> <td>0.309</td> <td>0.339</td> <td>0.369</td> </tr> <tr> <td>G_{x1}</td> <td>Green x¹</td> <td>0.294</td> <td>0.324</td> <td>0.354</td> </tr> <tr> <td>G_{y1}</td> <td>Green y¹</td> <td>0.592</td> <td>0.622</td> <td>0.652</td> </tr> <tr> <td>B_{x1}</td> <td>Blue x¹</td> <td>0.122</td> <td>0.152</td> <td>0.182</td> </tr> <tr> <td>B_{y1}</td> <td>Blue y¹</td> <td>0.023</td> <td>0.053</td> <td>0.083</td> </tr> <tr> <td>W_{x1}</td> <td>White x¹</td> <td>0.283</td> <td>0.313</td> <td>0.343</td> </tr> <tr> <td>W_{y1}</td> <td>White y¹</td> <td>0.299</td> <td>0.329</td> <td>0.359</td> </tr> </tbody> </table> 4.3.2 Recommended Operating Condition <table border="1"> <thead> <tr> <th>Symbol</th> <th>Description</th> <th>Min.</th> <th>Typ.</th> <th>Max.</th> <th>Unit</th> <th>Remark</th> </tr> </thead> <tbody> <tr> <td>I_{s1}</td> <td>LED String Current</td> <td>-</td> <td>50</td> <td>50</td> <td>[mA]</td> <td>100% duty ratio of LED chip</td> </tr> <tr> <td>V_{s1}</td> <td>LED String Voltage</td> <td>30.8</td> <td>35.2</td> <td>36.6</td> <td>[VOLT]</td> <td>Is=50mA @ 100% duty ratio. Note 4-1, Note 4-5</td> </tr> <tr> <td>ΔV_{s1}</td> <td>Maximum Vs Voltage Deviation of light bar</td> <td>-</td> <td>2.2</td> <td>-</td> <td>[VOLT]</td> <td>Is=50mA @ 100% duty ratio. Note 4-2</td> </tr> <tr> <td>P_{BLU1}</td> <td>LED Light Bar Power Consumption</td> <td>-</td> <td>7.0</td> <td>7.9</td> <td>[Watt]</td> <td>Note 4-3</td> </tr> <tr> <td>$L_{T,LED1}$</td> <td>LED Life Time</td> <td>30,000</td> <td>-</td> <td>-</td> <td>[Hour]</td> <td>Note 4-4</td> </tr> <tr> <td>OV_{P1}</td> <td>Over Voltage Protection in system board</td> <td>110%</td> <td>-</td> <td>-</td> <td>[VOLT]</td> <td>Note 4-5</td> </tr> </tbody> </table>	Symbol	Description	Min.	Typ.	Max.	Unit	Remark	R_{x1}	Color Coordinates (CIE 1931)	Red x ¹	0.609	0.639	0.669	By SR-3	R_{y1}	Red y ¹	0.309	0.339	0.369	G_{x1}	Green x ¹	0.294	0.324	0.354	G_{y1}	Green y ¹	0.592	0.622	0.652	B_{x1}	Blue x ¹	0.122	0.152	0.182	B_{y1}	Blue y ¹	0.023	0.053	0.083	W_{x1}	White x ¹	0.283	0.313	0.343	W_{y1}	White y ¹	0.299	0.329	0.359	Symbol	Description	Min.	Typ.	Max.	Unit	Remark	I_{s1}	LED String Current	-	50	50	[mA]	100% duty ratio of LED chip	V_{s1}	LED String Voltage	30.8	35.2	36.6	[VOLT]	Is=50mA @ 100% duty ratio. Note 4-1, Note 4-5	ΔV_{s1}	Maximum Vs Voltage Deviation of light bar	-	2.2	-	[VOLT]	Is=50mA @ 100% duty ratio. Note 4-2	P_{BLU1}	LED Light Bar Power Consumption	-	7.0	7.9	[Watt]	Note 4-3	$L_{T,LED1}$	LED Life Time	30,000	-	-	[Hour]	Note 4-4	OV_{P1}	Over Voltage Protection in system board	110%	-	-	[VOLT]	Note 4-5	
Symbol	Description	Min.	Typ.	Max.	Unit	Remark																																																																																																																																																																																																			
R_{x1}	Color Coordinates (CIE 1931)	Red x ¹	0.615	0.645	0.675	By SR-3																																																																																																																																																																																																			
R_{y1}		Red y ¹	0.314	0.344	0.374																																																																																																																																																																																																				
G_{x1}		Green x ¹	0.292	0.322	0.352																																																																																																																																																																																																				
G_{y1}		Green y ¹	0.604	0.634	0.664																																																																																																																																																																																																				
B_{x1}		Blue x ¹	0.124	0.154	0.184																																																																																																																																																																																																				
B_{y1}		Blue y ¹	0.020	0.050	0.080																																																																																																																																																																																																				
W_{x1}		White x ¹	0.283	0.313	0.343																																																																																																																																																																																																				
W_{y1}		White y ¹	0.299	0.329	0.359																																																																																																																																																																																																				
Symbol		Description	Min.	Typ.	Max.		Unit	Remark																																																																																																																																																																																																	
I_{s1}		LED String Current	-	60	60		[mA]	100% duty ratio of LED chip																																																																																																																																																																																																	
V_{s1}		LED String Voltage	30.8	35.2	36.6		[VDC]	Is=60mA @ 100% duty ratio. Note 4-1, Note 4-5																																																																																																																																																																																																	
ΔV_{s1}		Maximum Vs Voltage Deviation of light bar	-	2.2	-		[VDC]	Is=60mA @ 100% duty ratio. Note 4-2																																																																																																																																																																																																	
P_{BLU1}	LED Light Bar Power Consumption	-	8.4	9.5	[Watt]	Note 4-3																																																																																																																																																																																																			
$L_{T,LED1}$	LED Life Time	30,000	-	-	[Hour]	Note 4-4																																																																																																																																																																																																			
OV_{P1}	Over Voltage Protection in system board	110%	-	-	[VOLT]	Note 4-5																																																																																																																																																																																																			
Symbol	Description	Min.	Typ.	Max.	Unit	Remark																																																																																																																																																																																																			
R_{x1}	Color Coordinates (CIE 1931)	Red x ¹	0.609	0.639	0.669	By SR-3																																																																																																																																																																																																			
R_{y1}		Red y ¹	0.309	0.339	0.369																																																																																																																																																																																																				
G_{x1}		Green x ¹	0.294	0.324	0.354																																																																																																																																																																																																				
G_{y1}		Green y ¹	0.592	0.622	0.652																																																																																																																																																																																																				
B_{x1}		Blue x ¹	0.122	0.152	0.182																																																																																																																																																																																																				
B_{y1}		Blue y ¹	0.023	0.053	0.083																																																																																																																																																																																																				
W_{x1}		White x ¹	0.283	0.313	0.343																																																																																																																																																																																																				
W_{y1}		White y ¹	0.299	0.329	0.359																																																																																																																																																																																																				
Symbol		Description	Min.	Typ.	Max.		Unit	Remark																																																																																																																																																																																																	
I_{s1}		LED String Current	-	50	50		[mA]	100% duty ratio of LED chip																																																																																																																																																																																																	
V_{s1}		LED String Voltage	30.8	35.2	36.6		[VOLT]	Is=50mA @ 100% duty ratio. Note 4-1, Note 4-5																																																																																																																																																																																																	
ΔV_{s1}		Maximum Vs Voltage Deviation of light bar	-	2.2	-		[VOLT]	Is=50mA @ 100% duty ratio. Note 4-2																																																																																																																																																																																																	
P_{BLU1}	LED Light Bar Power Consumption	-	7.0	7.9	[Watt]	Note 4-3																																																																																																																																																																																																			
$L_{T,LED1}$	LED Life Time	30,000	-	-	[Hour]	Note 4-4																																																																																																																																																																																																			
OV_{P1}	Over Voltage Protection in system board	110%	-	-	[VOLT]	Note 4-5																																																																																																																																																																																																			
			Note 4-4: Definition of life time: a. Brightness of LED becomes to 50% of its original value b. Test condition: Is = 60mA and 25 \square (Room Temperature)	Note 4-4: Definition of life time: a. Brightness of LED becomes to 50% of its original value b. Test condition: Is = 50mA and 25 \square (Room Temperature)																																																																																																																																																																																																					

2.0	2016/1/20	All	Product specification release		ES7.0																																																																																																			
		23	3.5 Power ON/OFF Sequence <p style="text-align: center;">Power Sequence Timing</p> <table border="1"> <thead> <tr> <th rowspan="2">Symbol</th> <th colspan="3">Value</th> <th rowspan="2">Unit</th> <th rowspan="2">Remark</th> </tr> <tr> <th>Min.</th> <th>Typ.</th> <th>Max.</th> </tr> </thead> <tbody> <tr> <td>T1</td> <td>0.5</td> <td>-</td> <td>10</td> <td>[ms]</td> <td>-</td> </tr> <tr> <td>T2</td> <td>0</td> <td>-</td> <td>50</td> <td>[ms]</td> <td>-</td> </tr> <tr> <td>T3</td> <td>500</td> <td>-</td> <td>-</td> <td>[ms]</td> <td>-</td> </tr> <tr> <td>T4</td> <td>100</td> <td>-</td> <td>-</td> <td>[ms]</td> <td>-</td> </tr> <tr> <td>T5</td> <td>0</td> <td>-</td> <td>50</td> <td>[ms]</td> <td>Note 3-5 Note 3-6</td> </tr> <tr> <td>T6</td> <td>0</td> <td>-</td> <td>120</td> <td>[ms]</td> <td>Note 3-6</td> </tr> <tr> <td>T7</td> <td>100</td> <td>-</td> <td>-</td> <td>[ms]</td> <td>-</td> </tr> </tbody> </table> <p>Note 3-5: Recommend setting T5 = 0ms to avoid electrostatic noise when VDD is off.</p> <p>Note 3-6: During T5 and T6 period, please keep the level of input LVDS signals with Hi-Z state.</p>	Symbol	Value			Unit	Remark	Min.	Typ.	Max.	T1	0.5	-	10	[ms]	-	T2	0	-	50	[ms]	-	T3	500	-	-	[ms]	-	T4	100	-	-	[ms]	-	T5	0	-	50	[ms]	Note 3-5 Note 3-6	T6	0	-	120	[ms]	Note 3-6	T7	100	-	-	[ms]	-	3.5 Power ON/OFF Sequence <p style="text-align: center;">Power Sequence Timing</p> <table border="1"> <thead> <tr> <th rowspan="2">Symbol</th> <th colspan="3">Value</th> <th rowspan="2">Unit</th> <th rowspan="2">Remark</th> </tr> <tr> <th>Min.</th> <th>Typ.</th> <th>Max.</th> </tr> </thead> <tbody> <tr> <td>T1</td> <td>0.5</td> <td>-</td> <td>10</td> <td>[ms]</td> <td>-</td> </tr> <tr> <td>T2</td> <td>0</td> <td>-</td> <td>50</td> <td>[ms]</td> <td>-</td> </tr> <tr> <td>T3</td> <td>500</td> <td>-</td> <td>-</td> <td>[ms]</td> <td>-</td> </tr> <tr> <td>T4</td> <td>100</td> <td>-</td> <td>-</td> <td>[ms]</td> <td>-</td> </tr> <tr> <td>T5</td> <td>0</td> <td>-</td> <td>50</td> <td>[ms]</td> <td>Note 3-5 Note 3-6</td> </tr> <tr> <td>T6</td> <td>0</td> <td>-</td> <td>70</td> <td>[ms]</td> <td>Note 3-6 Note 3-7</td> </tr> <tr> <td>T7</td> <td>100</td> <td>-</td> <td>-</td> <td>[ms]</td> <td>-</td> </tr> </tbody> </table> <p>Note 3-5: Recommend setting T5 = 0ms to avoid electrostatic noise when VDD is off.</p> <p>Note 3-6: During T5 and T6 period, please keep the level of input LVDS signals with Hi-Z state.</p> <p>Note 3-7: Voltage of VDD must decay smoothly after power-off (caused by system deceleration).</p>	Symbol	Value			Unit	Remark	Min.	Typ.	Max.	T1	0.5	-	10	[ms]	-	T2	0	-	50	[ms]	-	T3	500	-	-	[ms]	-	T4	100	-	-	[ms]	-	T5	0	-	50	[ms]	Note 3-5 Note 3-6	T6	0	-	70	[ms]	Note 3-6 Note 3-7	T7	100	-	-
Symbol	Value				Unit	Remark																																																																																																		
	Min.	Typ.	Max.																																																																																																					
T1	0.5	-	10	[ms]	-																																																																																																			
T2	0	-	50	[ms]	-																																																																																																			
T3	500	-	-	[ms]	-																																																																																																			
T4	100	-	-	[ms]	-																																																																																																			
T5	0	-	50	[ms]	Note 3-5 Note 3-6																																																																																																			
T6	0	-	120	[ms]	Note 3-6																																																																																																			
T7	100	-	-	[ms]	-																																																																																																			
Symbol	Value			Unit	Remark																																																																																																			
	Min.	Typ.	Max.																																																																																																					
T1	0.5	-	10	[ms]	-																																																																																																			
T2	0	-	50	[ms]	-																																																																																																			
T3	500	-	-	[ms]	-																																																																																																			
T4	100	-	-	[ms]	-																																																																																																			
T5	0	-	50	[ms]	Note 3-5 Note 3-6																																																																																																			
T6	0	-	70	[ms]	Note 3-6 Note 3-7																																																																																																			
T7	100	-	-	[ms]	-																																																																																																			

1 Handling Precautions

- 1) Since front polarizer is easily damaged, pay attention not to scratch it.
- 2) Be sure to turn off power supply when inserting or disconnecting from input connector.
- 3) Wipe off water drop immediately. Long contact with water may cause discoloration or spots.
- 4) When the panel surface is soiled, wipe it with absorbent cotton or other soft cloth.
- 5) Since the panel is made of glass, it may break or crack if dropped or bumped on hard surface.
- 6) Since CMOS LSI is used in this module, take care of static electricity and insure human earth when handling.
- 7) Do not open or modify the Module Assembly.
- 8) Do not press the reflector sheet at the back of the module to any directions.
- 9) In case a TFT-LCD Module has to be put back into the packing container slot after once it was taken out from the container, do not press the center of the LED lightbar edge. Otherwise the TFT-LCD Module may be damaged.
- 10) Insert or pull out the interface connector, be sure not to rotate nor tilt it of the TFT-LCD Module.
- 11) Do not twist nor bend the TFT -LCD Module even momentary. It should be taken into consideration that no bending/twisting forces are applied to the TFT-LCD Module from outside. Otherwise the TFT-LCD Module may be damaged.
- 12) Please avoid touching COF position while you are doing mechanical design.
- 13) When storing modules as spares for a long time, the following precaution is necessary:
Store them in a dark place. Do not expose the module to sunlight or fluorescent light. Keep the temperature between 5 and 35 at normal humidity.
- 14) Do not apply the same pattern for a long time, it will enhance relevant defect.



2 General Description

This specification applies to the 19 inch wide Color a-Si TFT-LCD Module M190PW01 V8. The display supports the WXGA⁺ - 1440(H) x 900(V) screen format and 16.7M colors (8bits RGB data input). The input interface is Dual channel LVDS and this module doesn't contain an driver board for backlight.

2.1 Display Characteristics

The following items are characteristics summary on the table under 25□ condition:

ITEMS	Unit	SPECIFICATIONS
Screen Diagonal	[mm]	481.42 (18.95")
Active Area	[mm]	408.24 (H) x 255.15 (V)
Pixels H x V	-	1440(x3) x 900
Pixel Pitch	[um]	283.50 (per one triad) ×283.50
Pixel Arrangement	-	R.G.B. Vertical Stripe
Display Mode	-	TN Mode, Normally White
White Luminance (Center)	[cd/m ²]	250 (Typ.)
Contrast Ratio	-	1000 (Typ.)
Response Time	[msec]	5 (Typ., on/off)
Power Consumption (LCD Module + Backligh unit)	[Watt]	9.0 (Typ.) LCD module : PDD (Typ.)= 2.0 @ Black pattern,Fv=60Hz Backlight unit : P _{BLU} (Typ.) =7.0@Is=50mA
Weight	[Grams]	1520 (Typ)
Outline Dimension	[mm]	428.0(H) × 278.0(V) × 10.3(D) Typ.
Electrical Interface	-	Dual channel LVDS (8bits RGB data input)
Support Color	-	16.7M colors
Surface Treatment	-	Anti-Glare, 3H
Temperature Range		
Operating	[°C]	0 to +50
Storage (Shipping)	[°C]	-20 to +60
RoHS Compliance	-	RoHS Compliance
TCO Compliance	-	TCO 7.0 Compliance

2.2 Absolute Maximum Rating of Environment

Permanent damage may occur if exceeding the following maximum rating.

Symbol	Description	Min.	Max.	Unit	Remark
TOP	Operating Temperature	0	+50	[°C]	Note 2-1
TGS	Glass surface temperature (operation)	0	+65	[°C]	Note 2-1 Function judged only
HOP	Operation Humidity	5	90	[%RH]	Note 2-1
TST	Storage Temperature	-20	+60	[°C]	
HST	Storage Humidity	5	90	[%RH]	

Note 2-1: Temperature and relative humidity range are shown as the below figure.

1. 90% RH Max (Ta 39)
2. Max wet-bulb temperature at 39 or less. (Ta 39)
3. No condensation

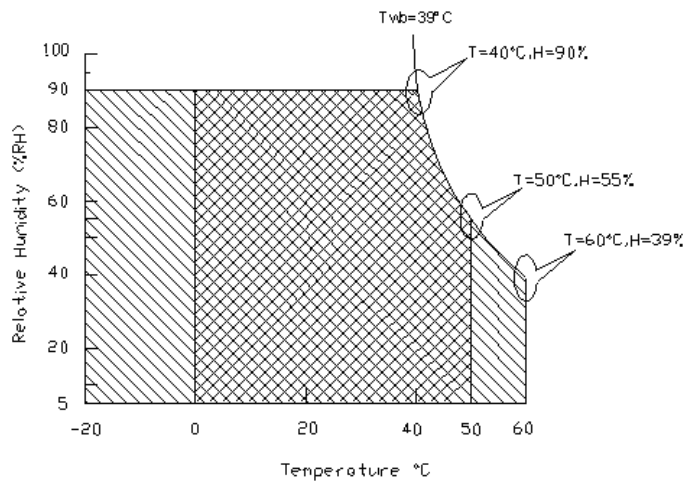

Operating Range



Storage Range

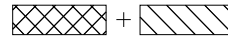

2.3 Optical Characteristics

The optical characteristics are measured on the following test condition.

Test Condition:

1. Equipment setup: Please refer to **Note 2-2**.
2. Panel Lighting time: 30 minutes
3. VDD=5.0V, Fv=60Hz, Is=50mA, Ta=25

Symbol	Description		Min.	Typ.	Max.	Unit	Remark
L _w	White Luminance (Center of screen)		200	250	-	[cd/m ²]	Note 2-2 By SR-3
L _{uni}	Luminance Uniformity (9 points)		75	80	-	[%]	Note 2-3 By SR-3
CR	Contrast Ratio (Center of screen)		600	1000	-	-	Note 2-4 By SR-3
θ _R	Horizontal Viewing Angle (CR=10)	Right	75	85	-	[degree]	Note 2-5 By SR-3
θ _L		Left	75	85	-		
Φ _H	Vertical Viewing Angle (CR=10)	Up	70	80	-		
Φ _L		Down	70	80	-		
θ _R	Horizontal Viewing Angle (CR=5)	Right	75	88	-		
θ _L		Left	75	88	-		
Φ _H	Vertical Viewing Angle (CR=5)	Up	70	85	-		
Φ _L		Down	70	85	-		
T _R	Response Time	Rising Time	-	3.5	5.5	[msec]	Note 2-6 By TRD-100
T _F		Falling Time	-	1.5	2.5		
-		Rising + Falling	-	5	8		
R _x	Color Coordinates (CIE 1931)	Red x	0.609	0.639	0.669	-	By SR-3
R _y		Red y	0.309	0.339	0.369		
G _x		Green x	0.294	0.324	0.354		
G _y		Green y	0.592	0.622	0.652		
B _x		Blue x	0.122	0.152	0.182		
B _y		Blue y	0.023	0.053	0.083		
W _x		White x	0.283	0.313	0.343		
W _y		White y	0.299	0.329	0.359		
CT	Crosstalk		-	-	1.5	[%]	Note 2-7 By SR-3
F _{dB}	Flicker (Center of screen)		-	-	-20	[dB]	Note 2-8 By SR-3

Note 2-2: Equipment setup :

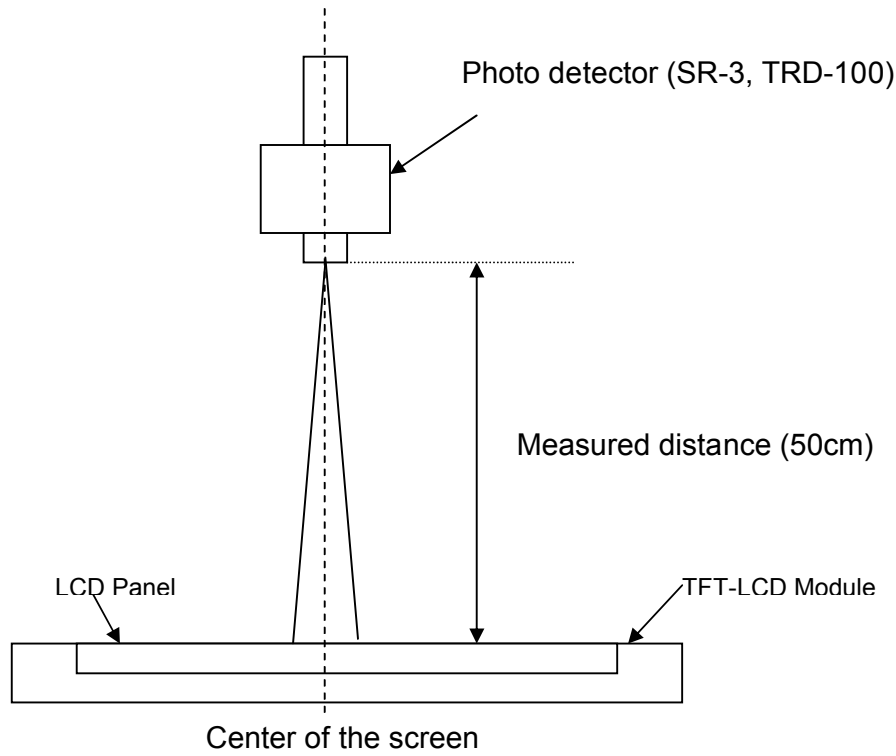

Note 2-3: Luminance Uniformity Measurement

Definition:

$$\text{Luminance Uniformity} = \frac{\text{Minimum Luminance of 9 Points (P1 ~ P9)}}{\text{Maximum Luminance of 9 Points (P1 ~ P9)}}$$

a. Test pattern: White Pattern

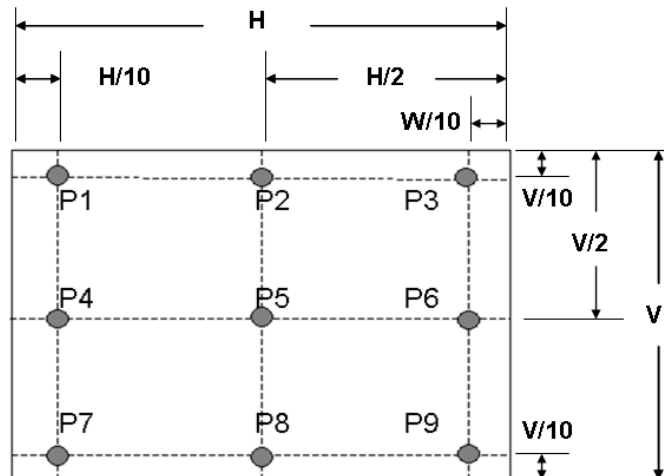

Note 2-4: Contrast Ratio Measurement

Definition:

$$\text{Contrast Ratio} = \frac{\text{Luminance of White pattern}}{\text{Luminance of Black pattern}}$$

- a. Measured position: Center of screen (P5) & perpendicular to the screen ($\theta = \Phi = 0^\circ$)

Note 2-5: Viewing angle measurement

Definition: The angle at which the contrast ratio is greater than 10 & 5 .

- a. Horizontal view angle: Divide to left & right (θ_L & θ_R)
 Vertical view angle: Divide to up & down (Φ_H & Φ_L)

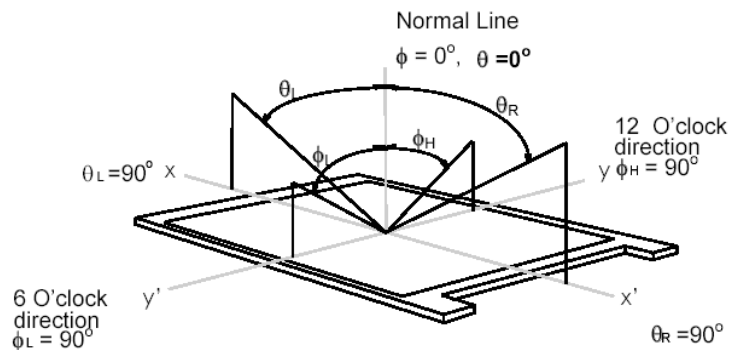

Note 2-6: Response time measurement

The output signals of photo detector are measured when the input signals are changed from “Black” to “White” (rising time, T_R), and from “White” to “Black” (falling time, T_F), respectively. The response time is interval between the 10% and 90% of optical response. (*Black & White color definition: Please refer section 3.4.3*)

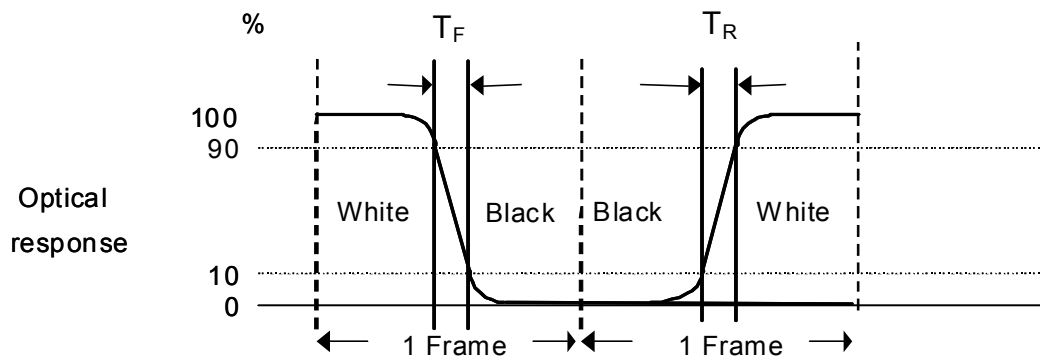

Note 2-7: Crosstalk measurement
Definition:

$$CT = \text{Max. } (CT_H, CT_V);$$

Where

a. Maximum Horizontal Crosstalk :

$$CT_H = \text{Max. } (| Y_{BL} - Y_{AL} | / Y_{AL} \times 100 \%, | Y_{BR} - Y_{AR} | / Y_{AR} \times 100 \%);$$

Maximum Vertical Crosstalk:

$$CT_V = \text{Max. } (| Y_{BU} - Y_{AU} | / Y_{AU} \times 100 \%, | Y_{BD} - Y_{AD} | / Y_{AD} \times 100 \%);$$

b. $Y_{AU}, Y_{AD}, Y_{AL}, Y_{AR}$ = Luminance of measured location without Black pattern

$Y_{BU}, Y_{BD}, Y_{BL}, Y_{BR}$ = Luminance of measured location with Black pattern

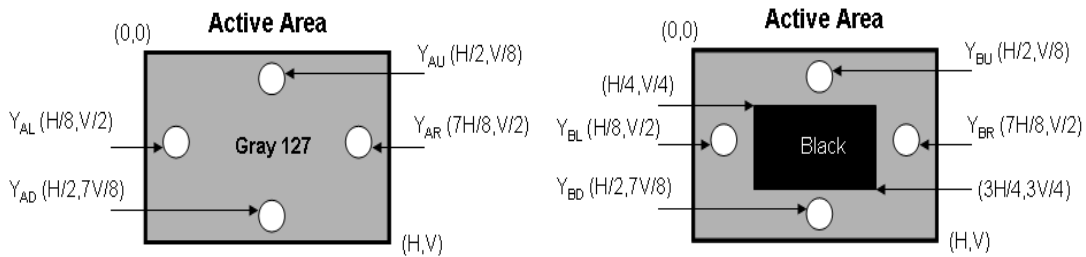
Note 2-8: Flicker measurement

a. Test pattern: It is listed as following.

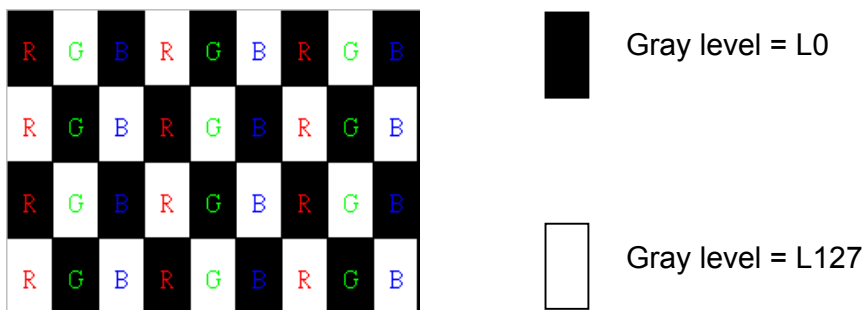

R: Red, G: Green, B:Blue

b. Measured position: Center of screen (P5) & perpendicular to the screen ($\theta = \Phi = 0^\circ$)

2.4 Mechanical Characteristics

Symbol	Description	Min.	Max.	Unit	Remark
P _{bc}	Backside Compression	2.5	-	[Kgf]	Note 2-9

Note 2-9: Test Method:

The point is at a distance from right-downside 25mm x 25mm defined as the Start Point of Measure Points, and the point is at a distance 25mm from left-side & around 10mm from PCB defined as the End Point.

Align 50mm x 50mm block from Start Point on the Bezel Back, and the corners of each block are Measure Points.

If the distance from the last block to each side of the End Point 25mm, add other blocks to make sure that most area of Bezel Back can be measured.

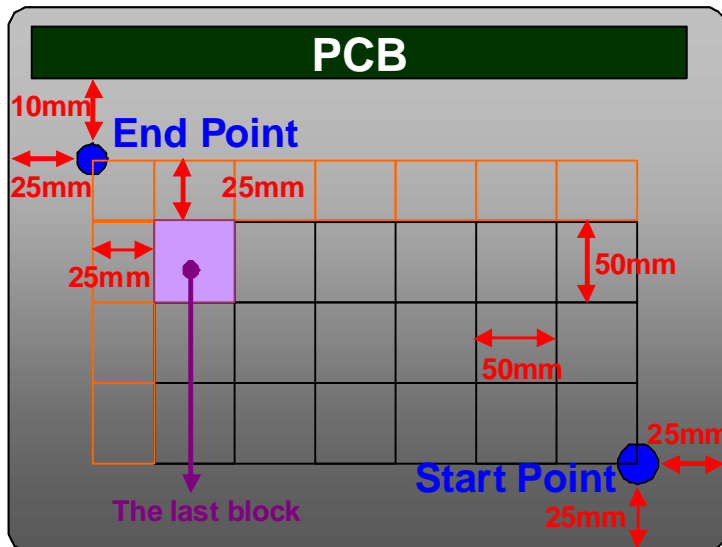

3 TFT-LCD Module

3.1 Block Diagram

The following shows the block diagram of the 19 inch Color TFT-LCD Module.

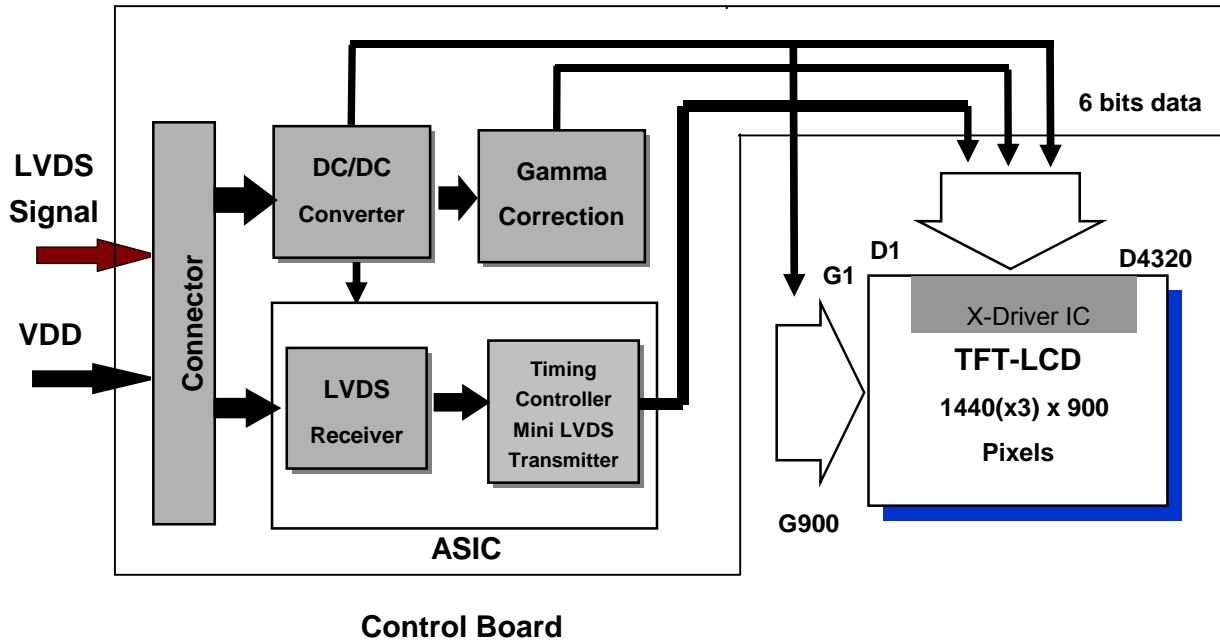

3.2 Interface Connection

3.2.1 Connector Type

TFT-LCD Connector	Manufacturer	STM	STARCONN
	Part Number	MSCKT2407P30HB	093G30-02001A-M4
Mating Connector	Manufacturer	JAE	
	Part Number	FI-X30HL (Locked Type)	

3.2.2 Connector Pin Assignment

PIN #	Symbol	Description	Remark
1	RxO0-	Negative LVDS differential data input (Odd data)	
2	RxO0+	Positive LVDS differential data input (Odd data)	
3	RxO1-	Negative LVDS differential data input (Odd data)	
4	RxO1+	Positive LVDS differential data input (Odd data)	
5	RxO2-	Negative LVDS differential data input (Odd data)	
6	RxO2+	Positive LVDS differential data input (Odd data)	
7	GND	Ground	
8	RxOCLK-	Negative LVDS differential clock input (Odd clock)	
9	RxOCLK+	Positive LVDS differential clock input (Odd clock)	
10	RxO3-	Negative LVDS differential data input (Odd data)	
11	RxO3+	Positive LVDS differential data input (Odd data)	
12	RxE0-	Negative LVDS differential data input (Even data)	
13	RxE0+	Positive LVDS differential data input (Even data)	
14	GND	Ground	
15	RxE1-	Negative LVDS differential data input (Even data)	
16	RxE1+	Positive LVDS differential data input (Even data)	
17	GND	Ground	
18	RxE2-	Negative LVDS differential data input (Even data)	
19	RxE2+	Positive LVDS differential data input (Even data)	
20	RxECLK-	Negative LVDS differential clock input (Even clock)	
21	RxECLK+	Positive LVDS differential clock input (Even clock)	
22	RxE3-	Negative LVDS differential data input (Even data)	
23	RxE3+	Positive LVDS differential data input (Even data)	
24	GND	Ground	
25	NC	No connection (for AUO test only. Do not connect)	
26	NC	No connection (for AUO test only. Do not connect)	

27	NC	No connection (for AUO test only. Do not connect)	
28	VDD	Power Supply Input Voltage	
29	VDD	Power Supply Input Voltage	
30	VDD	Power Supply Input Voltage	

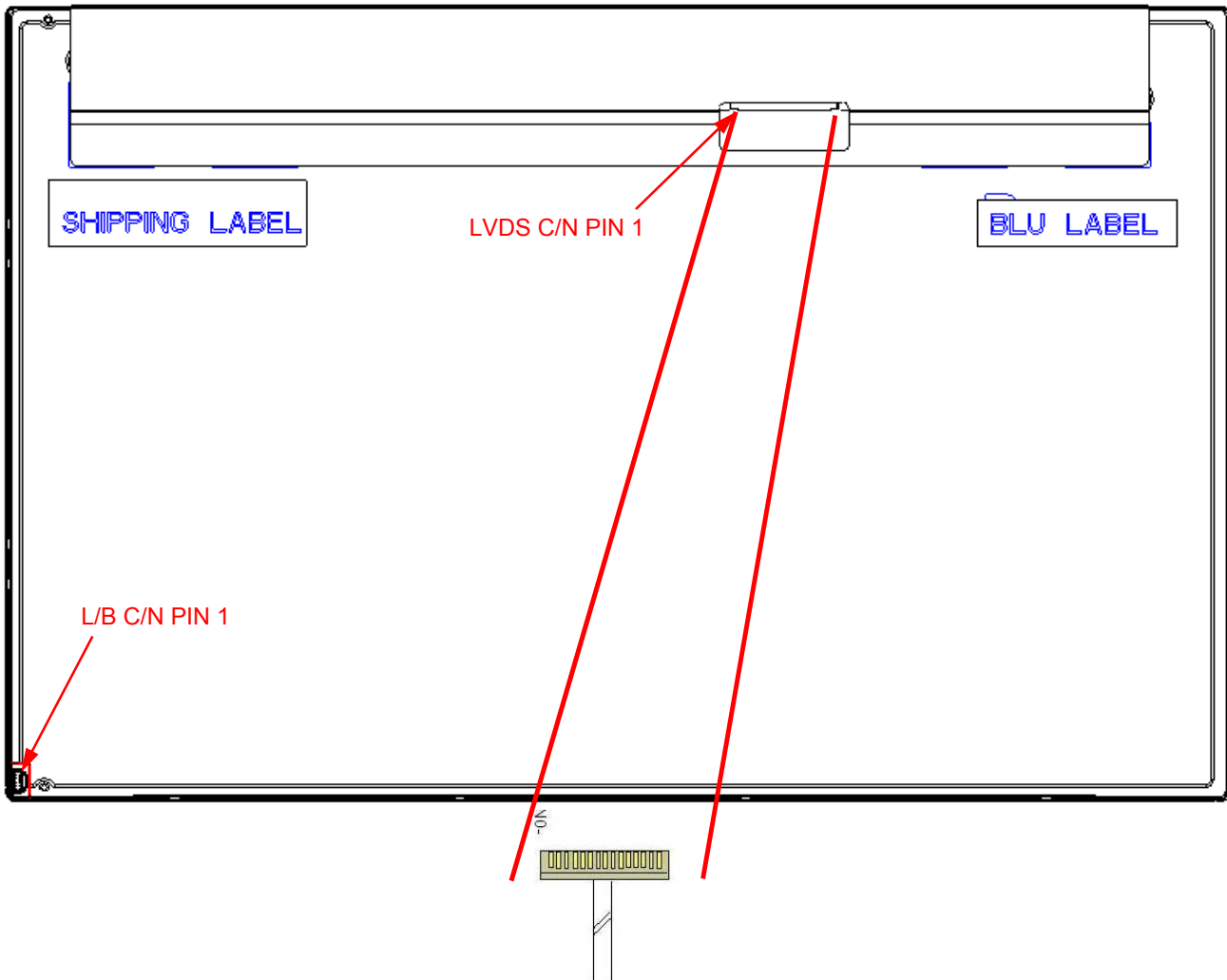

3.3 Electrical Characteristics

3.3.1 Absolute Maximum Rating

Permanent damage may occur if exceeding the following maximum rating.

Symbol	Description	Min	Max	Unit	Remark
VDD	Power Supply Input Voltage	GND-0.3	6.0	[Volt]	Ta=25□

3.3.2 Recommended Operating Condition

Symbol	Description	Min	Typ	Max	Unit	Remark
VDD	Power supply Input voltage	4.5	5.0	5.5	[Volt]	
IDD	Power supply Input Current (RMS)	-	0.4	0.5	[A]	VDD= 5.0V, Black Pattern, Fv=60Hz
		-	0.5	0.6	[A]	VDD= 5.0V, Black Pattern, Fv=75Hz
PDD	VDD Power Consumption	-	2.0	2.5	[Watt]	VDD= 5.0V, Black Pattern, Fv=60Hz
		-	2.5	3.0	[Watt]	VDD= 5.0V, Black Pattern, Fv=75Hz
IRush	Inrush Current	-	-	3.0	[A]	Note 3-1
VDDrp	Allowable VDD Ripple Voltage	-	-	500	[mV]	VDD= 5.0V, Black Pattern, Fv=75Hz

Note 3-1: Inrush Current measurement:

Test circuit:

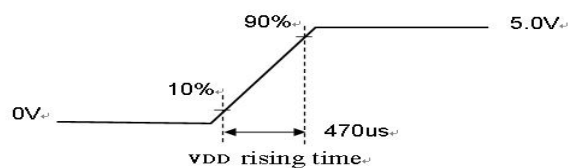
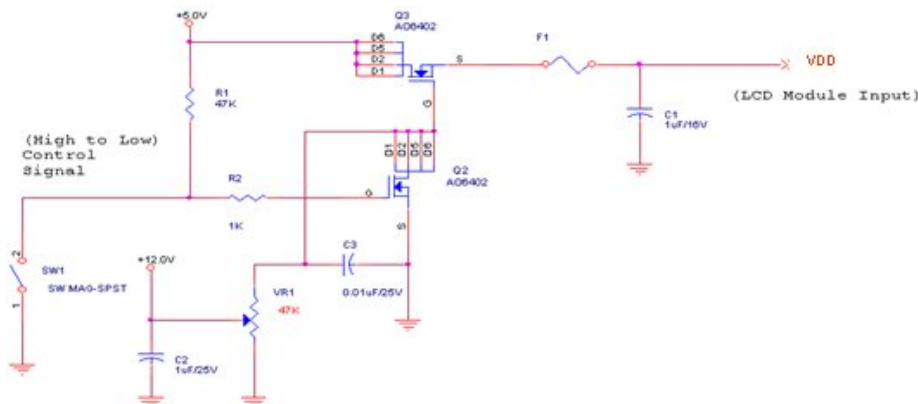

The duration of VDD rising time: 470us.

3.4 Signal Characteristics

3.4.1 LCD Pixel Format

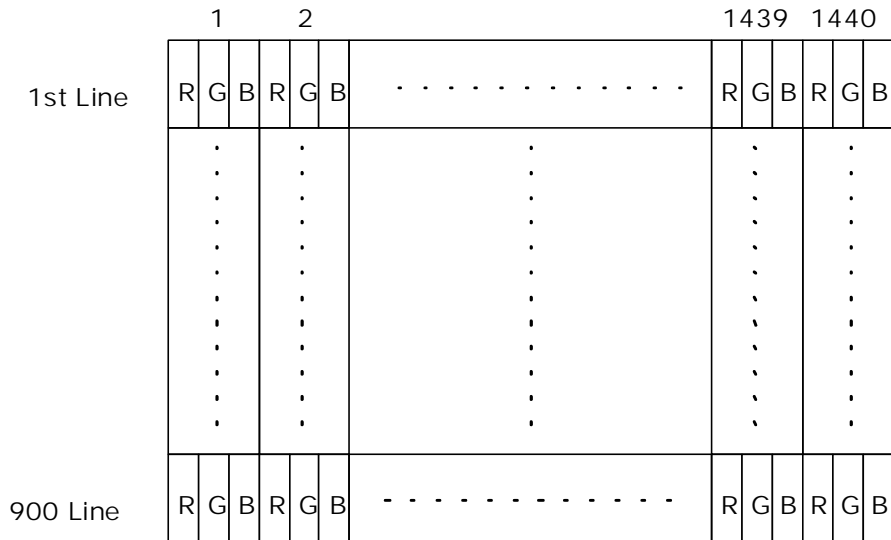

3.4.2 LVDS Data Format

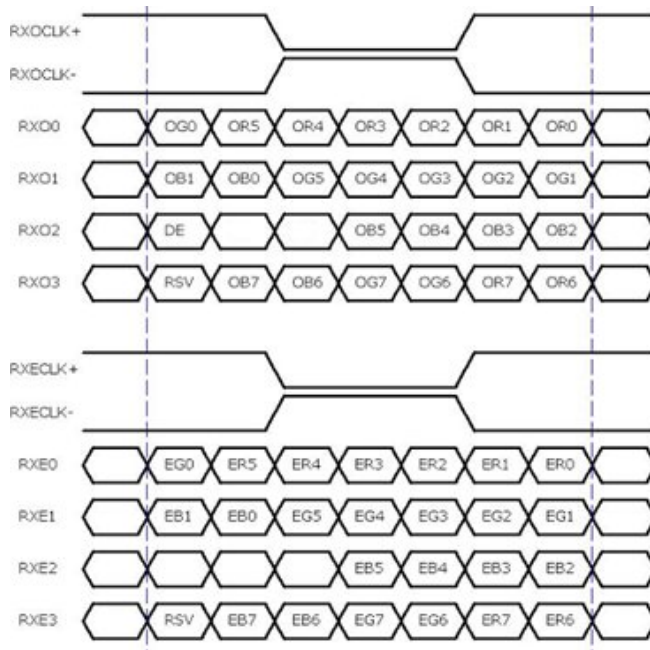

8 Bit Color Bit Order			
MSB	R7	G7	B7
	R6	G6	B6
	R5	G5	B5
	R4	G4	B4
	R3	G3	B3
	R2	G2	B2
	R1	G1	B1
LSB	R0	G0	B0

Note 3-2:

- a. O = "Odd Pixel Data" E = "Even Pixel Data"
- b. Refer to 3.4.1 LCD pixel format, the 1st data is 1 (Odd Pixel Data), the 2nd data is 2 (Even Pixel Data) and the last data is 1440 (Even Pixel Data).

3.4.3 Color versus Input Data

The following table is for color versus input data (8bit). The higher the gray level, the brighter the color.

Color	Gray Level	Color Input Data																								Remark
		RED data (MSB:R7, LSB:R0)								GREEN data (MSB:G7, LSB:G0)								BLUE data (MSB:B7, LSB:B0)								
		R7	R6	R5	R4	R3	R2	R1	R0	G7	G6	G5	G4	G3	G2	G1	G0	B7	B6	B5	B4	B3	B2	B1	B0	
Black	-	0	0	0	0	0	0	0	0	0	0	0	0	0	0	0	0	0	0	0	0	0	0	0	0	
White	-	1	1	1	1	1	1	1	1	1	1	1	1	1	1	1	1	1	1	1	1	1	1	1	1	
Gray 127	-	0	1	1	1	1	1	1	1	0	1	1	1	1	1	1	1	0	1	1	1	1	1	1	1	
Red	L0	0	0	0	0	0	0	0	0	0	0	0	0	0	0	0	0	0	0	0	0	0	0	0	0	Black
	:	:	:	:	:	:	:	:	:	:	:	:	:	:	:	:	:	:	:	:	:	:	:	:	:	
	L255	1	1	1	1	1	1	1	1	0	0	0	0	0	0	0	0	0	0	0	0	0	0	0	0	
Green	L0	0	0	0	0	0	0	0	0	0	0	0	0	0	0	0	0	0	0	0	0	0	0	0	0	Black
	:	:	:	:	:	:	:	:	:	:	:	:	:	:	:	:	:	:	:	:	:	:	:	:	:	
	L255	0	0	0	0	0	0	0	0	1	1	1	1	1	1	1	1	0	0	0	0	0	0	0	0	
Blue	L0	0	0	0	0	0	0	0	0	0	0	0	0	0	0	0	0	0	0	0	0	0	0	0	0	Black
	:	:	:	:	:	:	:	:	:	:	:	:	:	:	:	:	:	:	:	:	:	:	:	:	:	
	L255	0	0	0	0	0	0	0	0	0	0	0	0	0	0	0	0	1	1	1	1	1	1	1	1	

3.4.4 LVDS Specification

a. DC Characteristics:

Symbol	Description	Min	Typ	Max	Units	Condition
V_{TH}	LVDS Differential Input High Threshold	-	-	+100	[mV]	$V_{CM} = 1.2V$
V_{TL}	LVDS Differential Input Low Threshold	-100	-	-	[mV]	$V_{CM} = 1.2V$
V_{ID}	LVDS Differential Input Voltage	100	-	600	[mV]	
V_{CM}	LVDS Common Mode Voltage	+1.0	+1.2	+1.5	[V]	$V_{TH}-V_{TL} = 200mV$

LVDS Signal Waveform:

Use RxOCLK- & RxOCLK+ as example.

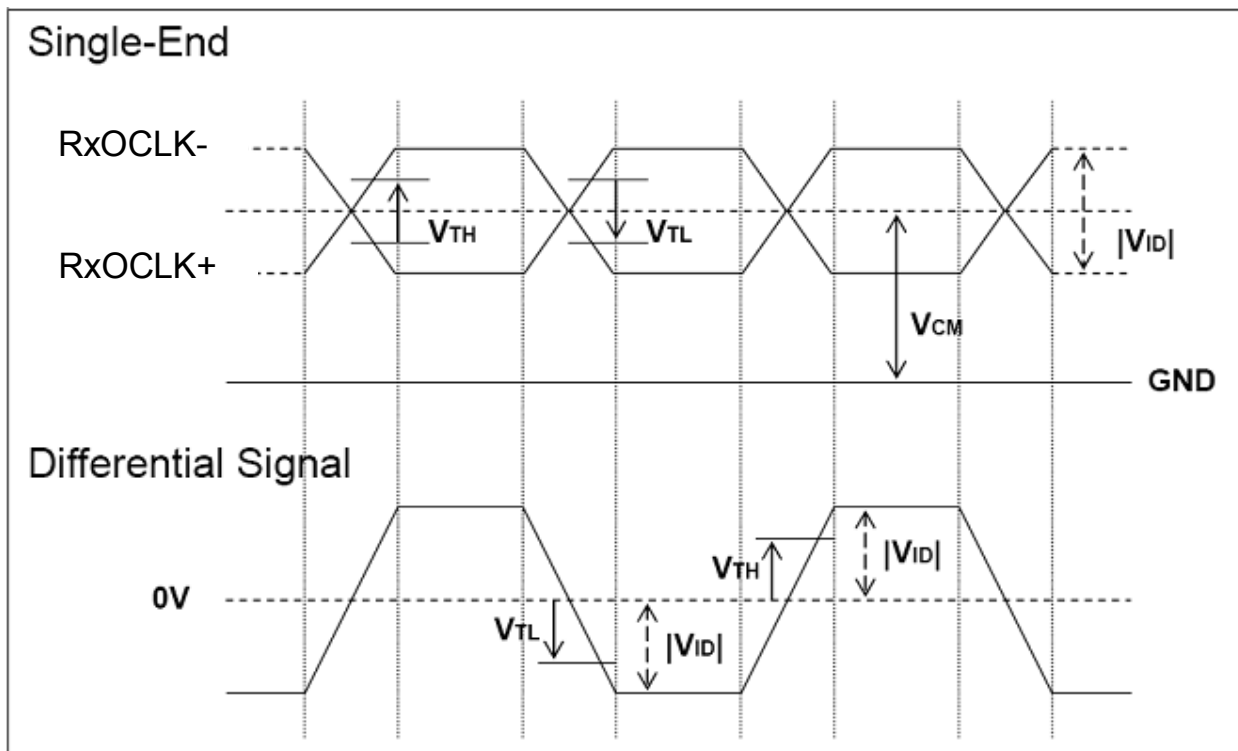

b. AC Characteristics:

Symbol	Description	Min	Max	Unit	Remark
F_{DEV}	Maximum deviation of input clock frequency during Spread Spectrum	-	± 3	%	
F_{MOD}	Maximum modulation frequency of input clock during Spread Spectrum	-	200	KHz	

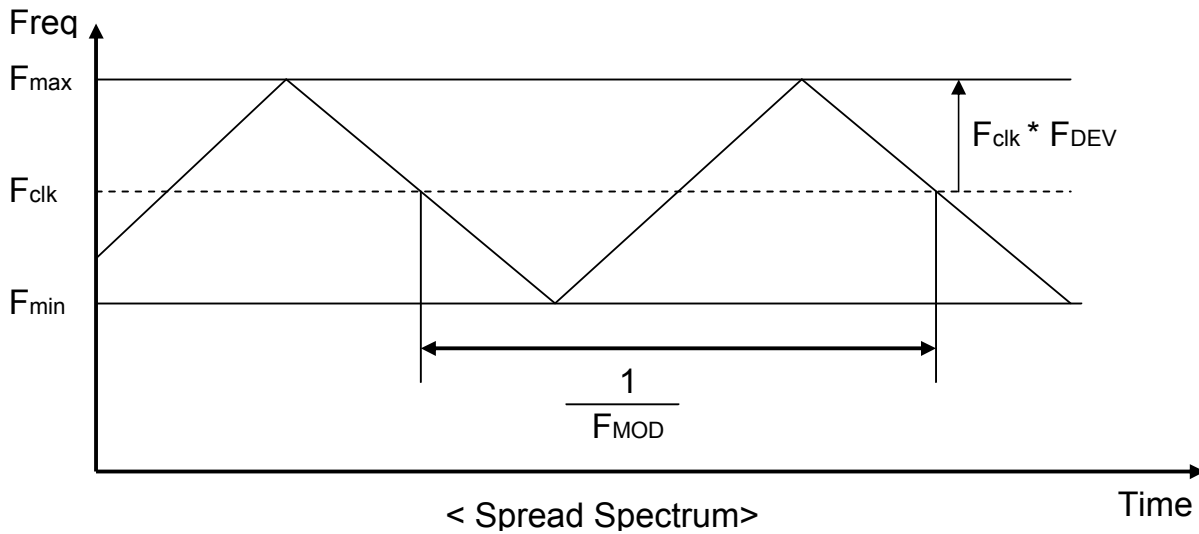

Fclk: LVDS Clock Frequency

3.4.5 Input Timing Specification

It only support DE mode, and the input timing are shown as the following table.

Symbol	Description		Min.	Typ.	Max.	Unit	Remark
Tv	Vertical Section	Period	914	916	1801	Th	
Tdisp (v)		Active	900	900	900	Th	
Tblk (v)		Blanking	14	16	901	Th	
Fv		Frequency	49	60	76	Hz	
Th	Horizontal Section	Period	760	964	1498	Tclk	
Tdisp (h)		Active	720	720	720	Tclk	
Tblk (h)		Blanking	40	244	778	Tclk	
Fh		Frequency	44.9	55.0	88.2	KHz	Note 3-3
Tclk	LVDS Clock	Period	15.0	18.9	29.3	ns	1/Fclk
Fclk		Frequency	34.1	53.0	67.1	MHz	Note 3-4

Note 3-3: The equation is listed as following. Please don't exceed the above recommended value.

$$\begin{aligned}
 Fh (\text{Min.}) &= Fclk (\text{Min.}) / Th (\text{Min.}); \\
 Fh (\text{Typ.}) &= Fclk (\text{Typ.}) / Th (\text{Typ.}); \\
 Fh (\text{Max.}) &= Fclk (\text{Max.}) / Th (\text{Min.});
 \end{aligned}$$

Note 3-4: The equation is listed as following. Please don't exceed the above recommended value.

$$\begin{aligned}
 Fclk (\text{Min.}) &= Fv (\text{Min.}) \times Th (\text{Min.}) \times Tv (\text{Min.}); \\
 Fclk (\text{Typ.}) &= Fv (\text{Typ.}) \times Th (\text{Typ.}) \times Tv (\text{Typ.}); \\
 Fclk (\text{Max.}) &= Fv (\text{Max.}) \times Th (\text{Typ.}) \times Tv (\text{Typ.});
 \end{aligned}$$

3.4.6 Input Timing Diagram

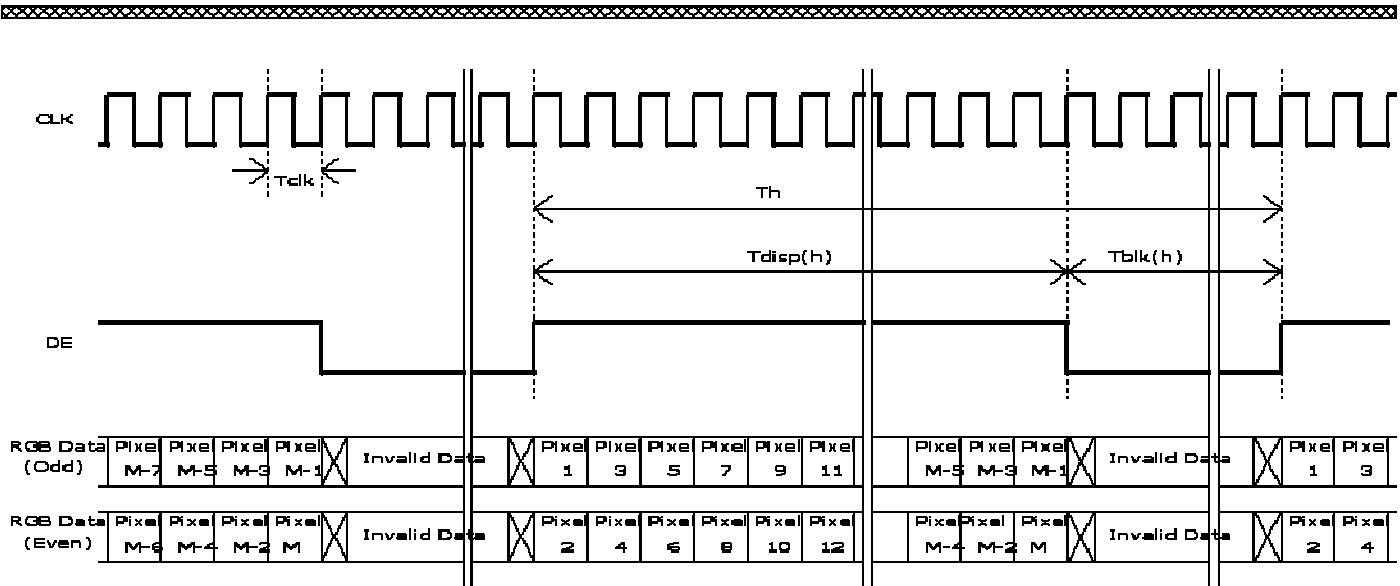
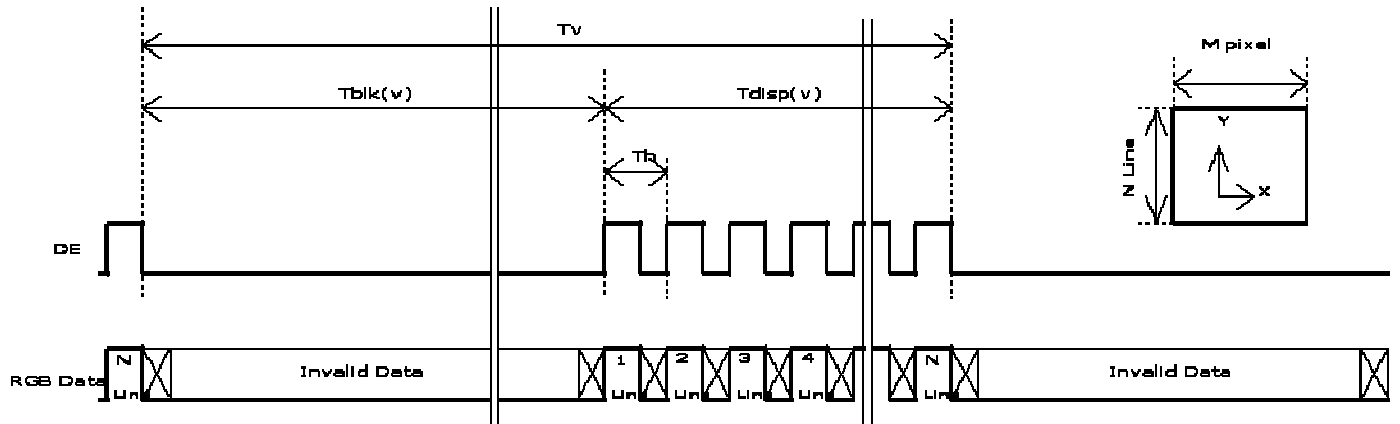

3.5 Power ON/OFF Sequence

VDD power, LVDS signal and backlight on/off sequence are as following. LVDS signals from any system shall be Hi-Z state when VDD is off.

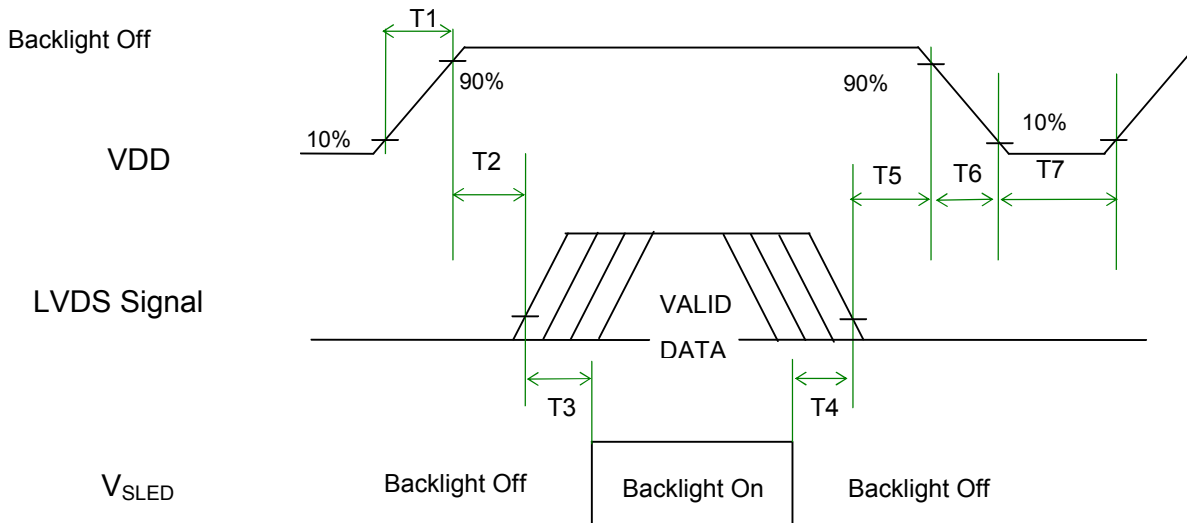

Power Sequence Timing

Symbol	Value			Unit	Remark
	Min.	Typ.	Max.		
T1	0.5	-	10	[ms]	
T2	0	-	50	[ms]	
T3	500	-	-	[ms]	
T4	100	-	-	[ms]	
T5	0	-	50	[ms]	Note 3-5 Note 3-6
T6	0	-	200	[ms]	Note 3-6 Note 3-7
T7	1000	-	-	[ms]	

Note 3-5 : Recommend setting T5 = 0ms to avoid electronic noise when VDD is off.

Note 3-6 : During T5 and T6 period , please keep the level of input LVDS signals with Hi-Z state.

Note 3-7 : Voltage of VDD must decay smoothly after power-off.(customer system decide this value)

4 Backlight Unit

4.1 Block Diagram

The following shows the block diagram of the 19 inch Backlight Unit. And it includes 44 pcs LED in the LED light bar. (4 strings and 11 pcs LED of one string).

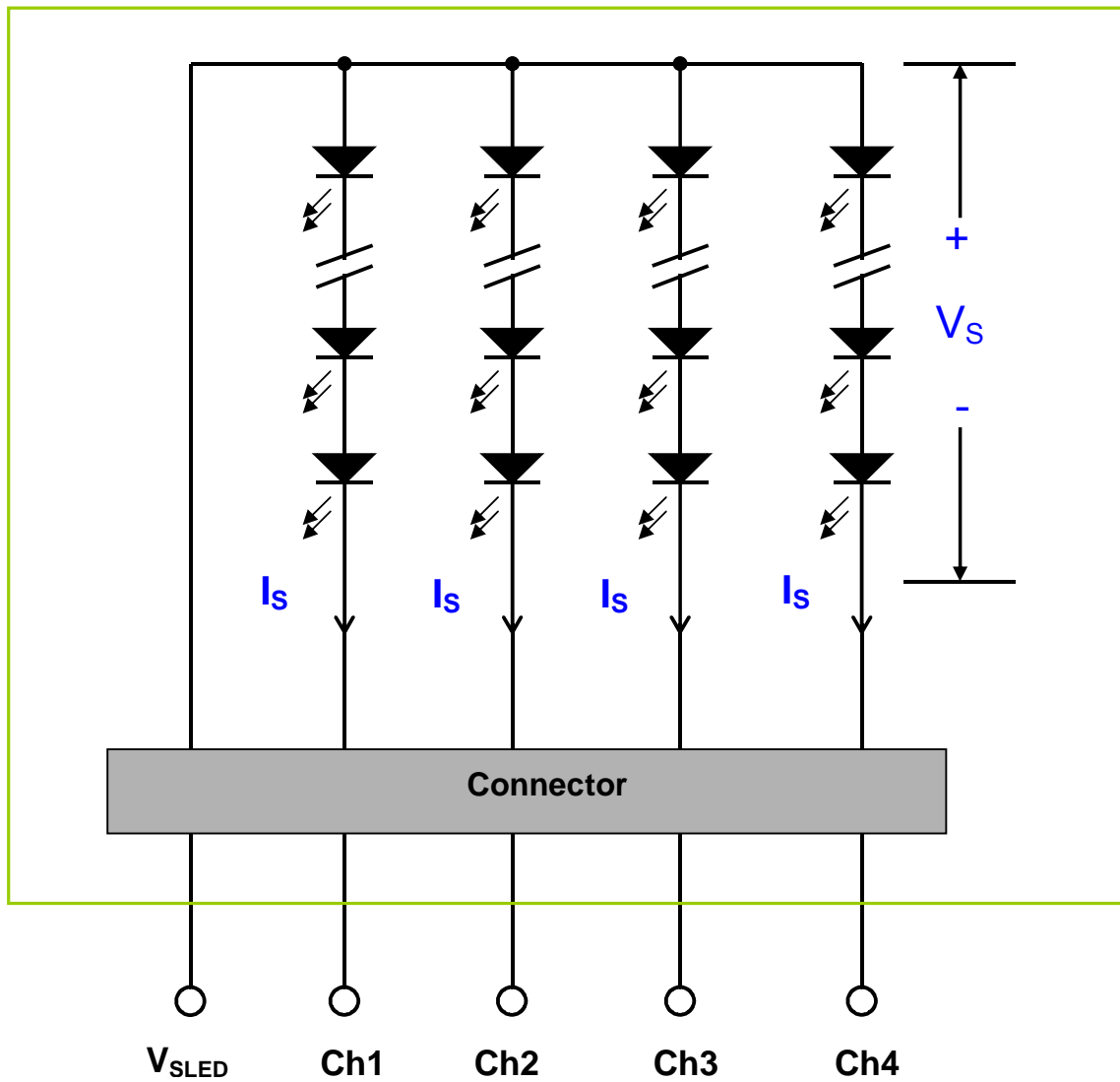

4.2 Interface Connection

4.2.1 Connector Type

Backlight Connector	Manufacturer	ENTERY
	Part Number	3707K-S06N-21R
Mating Connector	Manufacturer	ENTERY
	Part Number	H112K-P06N-13B (Locking type)

Backlight Connector dimension:

$H \times V \times D = 7.9 \times 3.05 \times 4.25$, Pitch = 1.0(unit = mm)

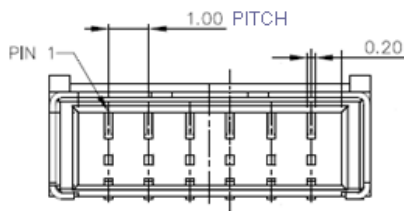
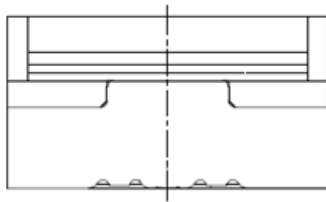

Mating Connector dimension:

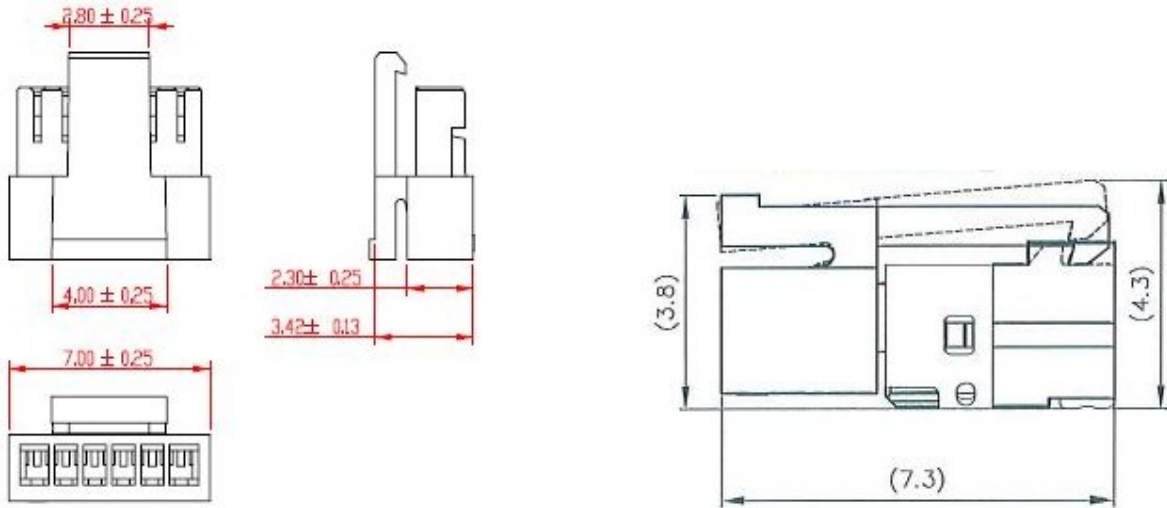

4.2.2 Connector Pin Assignment

Pin#	Symbol	Description	Remark
1	Ch1	LED Current Feedback Terminal (Channel 1)	
2	Ch2	LED Current Feedback Terminal (Channel 2)	
3	V _{SLED}	LED Power Supply Voltage Input Terminal	
4	V _{SLED}	LED Power Supply Voltage Input Terminal	
5	Ch3	LED Current Feedback Terminal (Channel 3)	
6	Ch4	LED Current Feedback Terminal (Channel 4)	

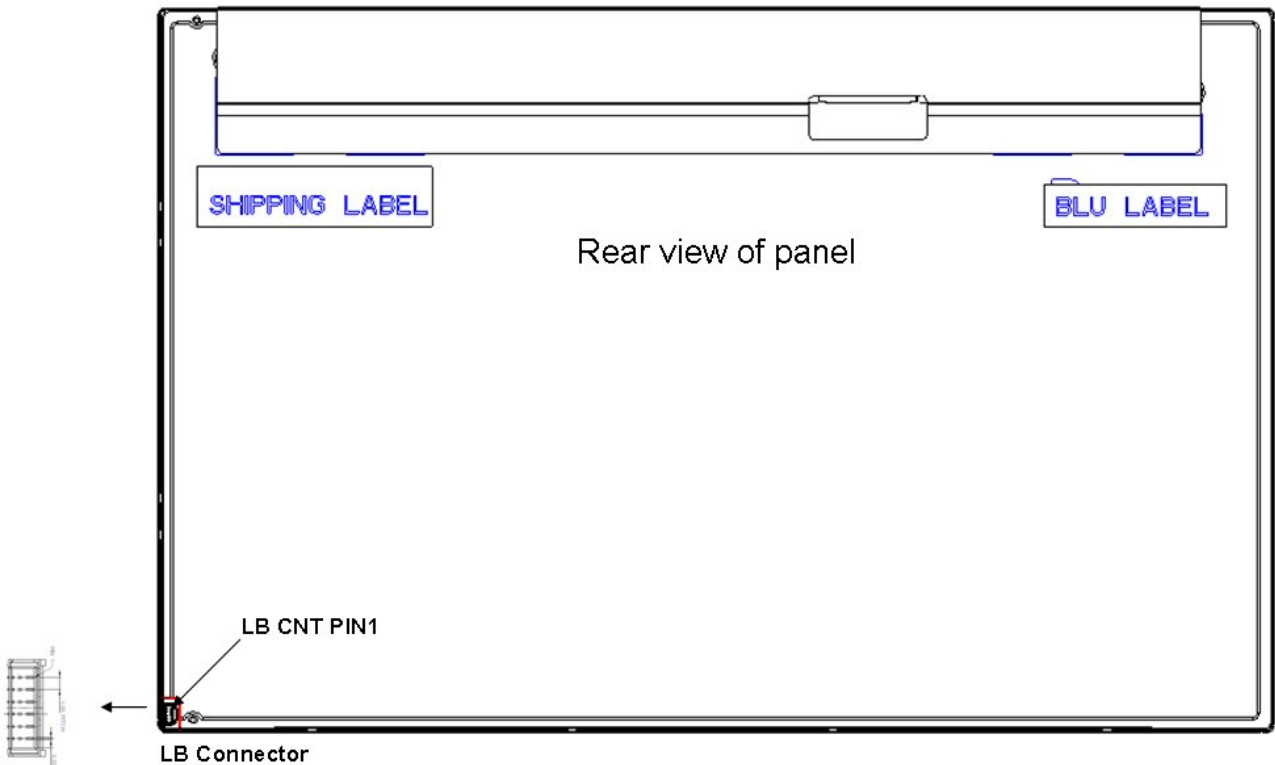

4.3 Electrical Characteristics

4.3.1 Absolute Maximum Rating

Permanent damage may occur if exceeding the following maximum rating.

(Ta=25 °C)

Symbol	Description	Min	Max	Unit	Remark
Is	LED String Current	0	90	[mA]	100% duty ratio
			150	[mA]	Duty ratio 10% Pulse time=10 ms

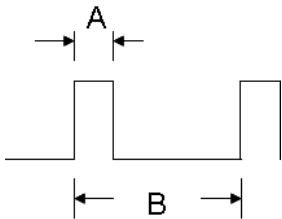

Duty ratio= (A / B) X 100% ; (A: Pulse time, B: Period)

4.3.2 Recommended Operating Condition

(Ta=25 °C)

Symbol	Description	Min.	Typ.	Max.	Unit	Remark
Is	LED String Current	-	50	55	[mA]	100% duty ratio of LED chip
Vs	LED String Voltage	30.8	35.2	39.6	[Volt]	Is=50mA @ 100% duty ratio; Note 4-1, Note 4-5
ΔVs	Maximum Vs Voltage Deviation of light bar	-	-	2.2	[Volt]	Is=50mA @ 100% duty ratio; Note 4-2
P _{BLU}	LED Light Bar Power Consumption	-	7.0	7.9	[Watt]	Note 4-3
LT _{LED}	LED Life Time	30,000	-	-	[Hour]	Note 4-4
OVP	Over Voltage Protection in system board	110% V _{smax}	-	-	[Volt]	Note 4-5

Note 4-1: V_s (Typ.) = V_F (Typ.) X LED No. (one string);

a. V_F : LED chip forward voltage, V_F (Min.)=2.8V, V_F (Typ.)=3.2V, V_F (Max.)=3.6V

b. The same equation to calculate V_s (Min.) & V_s (Max.) for respective V_F (Min.) & V_F (Max.);

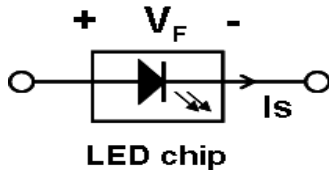

Note 4-2: ΔV_s (Max.) = ΔV_F X LED No. (one string);

a. ΔV_F : LED chip forward voltage deviation; (0.2 V , each Bin of LED V_F)

Note 4-3: P_{BLU} (Typ.) = V_s (Typ.) X I_s (Typ.) X 4 ; (4 is total String No. of LED Light bar)

P_{BLU} (Max.) = V_s (Max.) X I_s (Typ.) X 4 ;

Note 4-4: Definition of life time:

a. Brightness of LED becomes to 50% of its original value

b. Test condition: I_s = 50mA and 25 (Room Temperature)

Note 4-5: Recommendation for LED driver power design:

Due to there are electrical property deviation in LED & monitor set system component after long time operation. AUO strongly recommend the design value of LED driver board OVP (over voltage protection) should be 10% higher than max. value of LED string voltage (V_s) at least.

Note 4-6: AUO strongly recommend “ Analog Dimming ” method for backlight brightness control for Wavy Noise Free. Otherwise, recommend that Dimming Control Signal (PWM Signal) should be synchronized with Frame Frequency.

Note 4-7: Ensure that the LED light bar is not subjected either forward or reverse voltage while monitor set is on standby mode or not in use.



5 Reliability Test

AUO reliability test items are listed as following table. (Bare Panel only)

Items	Condition	Remark
Temperature Humidity Bias (THB)	Ta= 50□, 80%RH, 300hours	
High Temperature Operation (HTO)	Ta= 50□, 50%RH, 300hours	
Low Temperature Operation (LTO)	Ta= 0□, 300hours	
High Temperature Storage (HTS)	Ta= 60□, 300hours	
Low Temperature Storage (LTS)	Ta= -20□, 300hours	
Vibration Test (Non-operation)	Acceleration: 1.5 Grms Wave: Random Frequency: 10 - 200 Hz Sweep: 30 Minutes each Axis (X, Y, Z)	
Shock Test (Non-operation)	Acceleration: 50 G Wave: Half-sine Active Time: 20 ms Direction: ±X, ±Y, ±Z (one time for each Axis)	
Thermal Shock Test (TST)	-20□/30min, 60□/30min, 100 cycles	Note 5-1
On/Off Test	On/10sec, Off/10sec, 30,000 cycles	
ESD (Electro Static Discharge)	Contact Discharge: ± 15KV, 150pF(330Ω) 1sec, 8 points, 25 times/ point.	Note 5-2
	Air Discharge: ± 15KV, 150pF(330Ω) 1sec 8 points, 25 times/ point.	
Altitude Test	Operation:18,000 ft Non-Operation:40,000 ft	

Note 5-1: a. A cycle of rapid temperature change consists of varying the temperature from -20□ to 60□, and back again. Power is not applied during the test.
b. After finish temperature cycling, the unit is placed in normal room ambient for at least 4 hours before power on.

Note 5-2: EN61000-4-2, ESD class B: Certain performance degradation allowed
No data lost
Self-recoverable
No hardware failures.

6 Shipping Label

The label is on the panel as shown below:

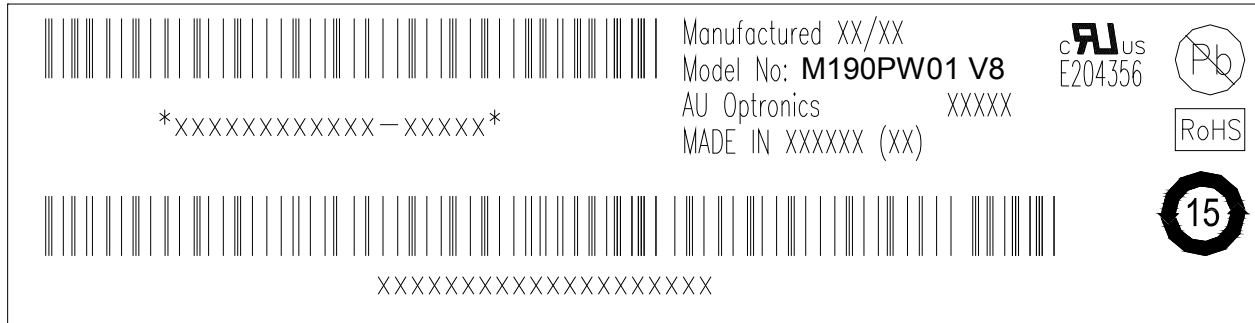

Note 6-1: For Pb Free products, AUO will add  for identification.

Note 6-2: For RoHS compatible products, AUO will add  for identification.

Note 6-3: For China RoHS compatible products, AUO will add  for identification.

Note 6-4: The Green Mark will be presented only when the green documents have been ready by AUO Internal Green Team.

7 Mechanical Characteristics

- NOTES:
 1. THE DIMENSION EXCLUDES DEFORMATION.
 2. TOLERANCE WITHOUT NOTICED TO BE $\pm 0.5\text{MM}$.
 3. SUGGEST FOR CUSTOMER SCREW SELECTION:
 CUSTOMER ASSEMBLY TOLERANCE + CUSTOMER CHASSIS THICKNESS
 4. LB CONNECTOR TO BE 3707K-S06N-2I.
 5. TORQUE OF M3 USER HOLE SHOULD BE WITHIN 4 KGF-CM
 AND RE-SCREW 10 TIMES.

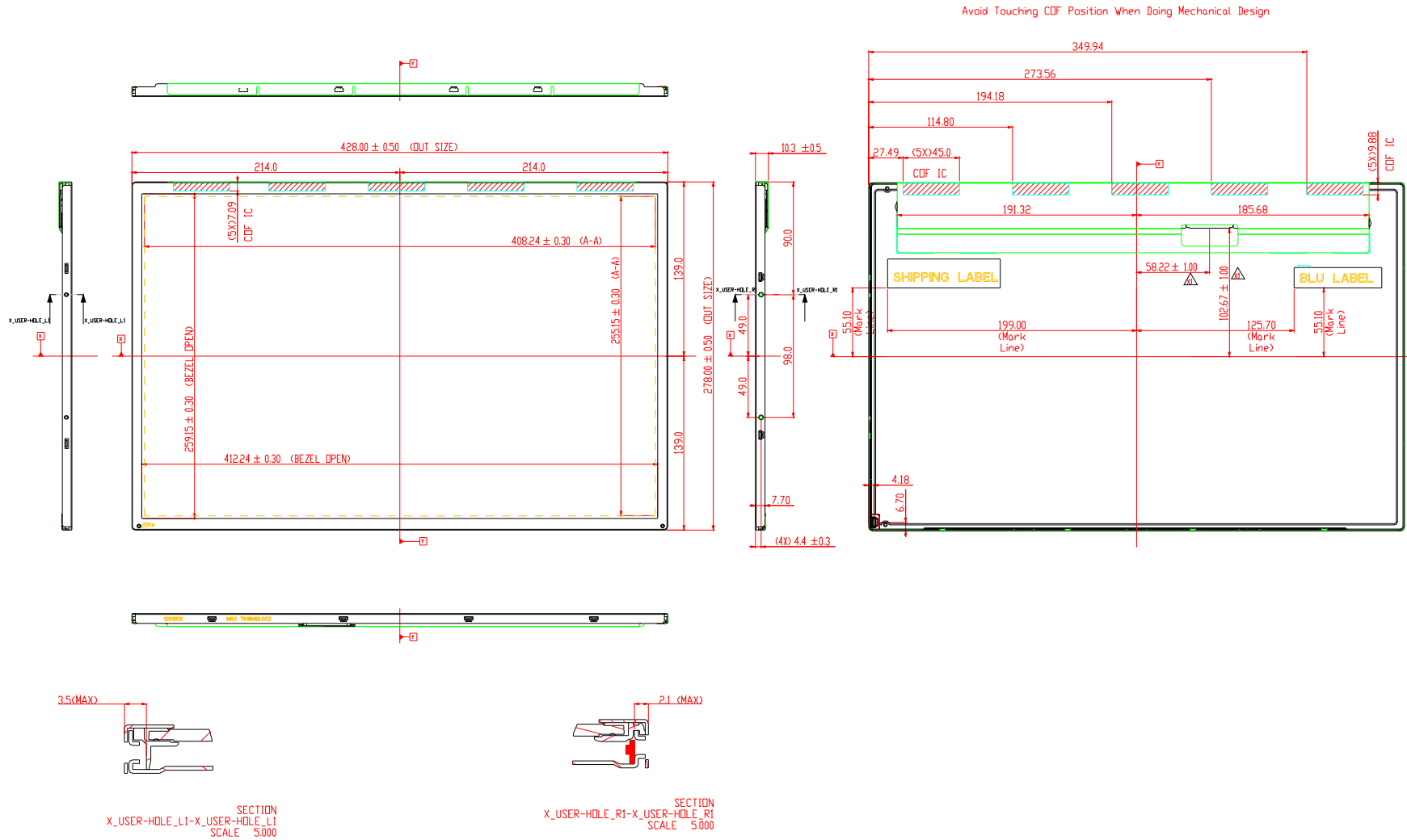

8 Packing Specification

8.1 Packing Flow

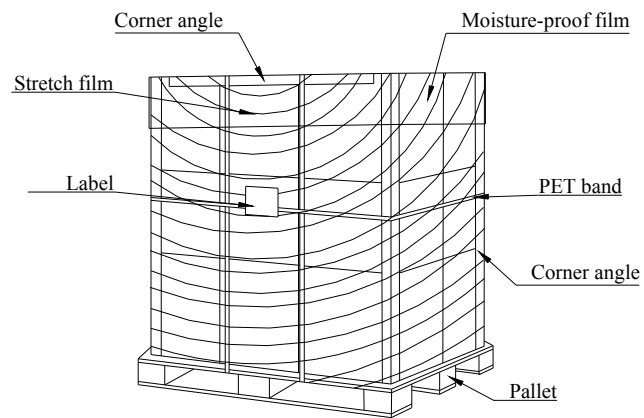
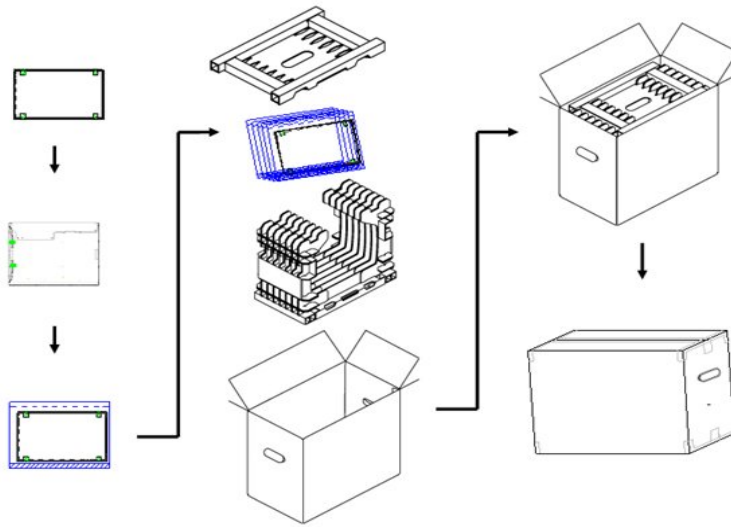

8.2 Pallet and shipment information

Item	Specification			Remark
	Q'ty	Dimension	Weight(kg)	
Panel	1	428(H)mm × 278(V)mm × 11(D)mm	1.520	
Cushion	1	-	1.88	
Box	1	524(L)mm x 282(W)mm x 356(H)mm	1.10	without Panel & cushion
Packing Box	10 pcs/Box	524(L)mm x 282(W)mm x 356(H)mm	18.18	with panel & cushion
Pallet	1	1150(L)mm x 1070(W)mm x 132(H)mm	15.0	
Pallet after Packing	18 boxes/pallet	1150(L)mm x 1070(W)mm x 1208(H)mm	448.3	