

Doc. Number :

Tentative Specification
Preliminary Specification
Approval Specification

MODEL NO.: M195FGE
SUFFIX: P02

Customer:	
APPROVED BY	SIGNATURE
Name / Title _____	_____
Note Product Version C1	
<hr/> Please return 1 copy for your confirmation with your signature and comments.	

Approved By	Checked By	Prepared By
吳柏勳	柯直孝	許文進

- CONTENTS -

1. GENERAL DESCRIPTION	4
1.1 OVERVIEW	4
1.2 GENERAL SPECIFICATIONS	4
2. MECHANICAL SPECIFICATIONS	4
3. ABSOLUTE MAXIMUM RATINGS	4
3.1 ABSOLUTE RATINGS OF ENVIRONMENT	4
3.2 ELECTRICAL ABSOLUTE RATINGS	5
3.2.1 TFT LCD MODULE	5
3.3 ABSOLUTE RATINGS OF ENVIRONMENT (OPEN CELL)	5
4. ELECTRICAL SPECIFICATIONS	6
4.1 FUNCTION BLOCK DIAGRAM	6
4.2. INTERFACE CONNECTIONS	6
Connector Information	7
4.3 ELECTRICAL CHARACTERISTICS	8
4.4 V _{CC} POWER DIP CONDITION	10
4.5 LVDS DATA MAPPING TABLE	10
4.6 COLOR DATA INPUT ASSIGNMENT	11
4.7 DISPLAY TIMING SPECIFICATIONS	12
4.8 POWER ON/OFF SEQUENCE	14
5. OPTICAL CHARACTERISTICS	15
5.1 TEST CONDITIONS	15
5.2 OPTICAL SPECIFICATIONS	15
5.3 Flicker Adjustment	18
6. RELIABILITY TEST ITEM	19
7. LABEL	20
7.1 INNOLUX OPEN CELL LABEL	20
8. PACKING	21
8.1 Packing Information	21
8.2 CARTON	21
9.1 ASSEMBLY AND HANDLING PRECAUTIONS	23
9.2 SAFETY PRECAUTIONS	25
10. OUTLINE DRAWING	26

REVISION HISTORY

Version	Date	Page	Description
1.0	Nov.2012	All	Spec Ver.1.0 was first issued.
2.0		4	1.2 GENERAL SPECIFICATIONS Power Consumption(MAX) 4.55W→4.7W
		7	4.2. INTERFACE CONNECTIONS To modify Connector Information
		8	4.3.1 LCD ELETRONICS SPECIFICATION To modify Power Supply Current (typ/max) Black : 0.77/0.87 → 0.83/0.94 A V-strip : 0.91/1.05 → 0.62/0.69 A To modify Power Consumption(typ/max) 4.55/5.25 → 4.15/4.7 Watt To add specification of Differential Input High & Low Threshold Voltage
		11	4.3.1 LCD ELETRONICS SPECIFICATION Modify description of Note(5) & update figure
		14	4.8 POWER ON/OFF SEQUENCE Modify Time Specification table
		15	5.2 OPTICAL SPECIFICATIONS Color Chromaticity (CIE 1931) Modify Rx, Gx, By
		21	8.2 CARTON To update packing drawing

1. GENERAL DESCRIPTION

1.1 OVERVIEW

The M195FGE-P02 is a 19.5" TFT LCD cell with driver ICs and a 30-pins-2ch-LVDS circuit board.
 The product supports 1600 x 900 HD+ mode and can display up to 16.7M colors. The backlight unit is not built in.

1.2 GENERAL SPECIFICATIONS

Item	Specification	Unit	Note
Screen Size	19.5" real diagonal		
Driver Element	a-si TFT active matrix	-	-
Pixel Number	1600 x R.G.B. x 900	pixel	-
Pixel Pitch	0.27 (H) x 0.27 (V)	mm	-
Pixel Arrangement	RGB vertical stripe	-	-
Display Colors	16.7M	color	-
Transmissive Mode	Normally white	-	-
Surface Treatment	AG type, 3H hard coating, Haze 25	-	-
Power Consumption	4.7 (Max)	Watt	-

2. MECHANICAL SPECIFICATIONS

Item	Min.	Typ.	Max.	Unit	Note
Weight	-	345	365	g	-
I/F connector mounting position	The mounting inclination of the connector makes the screen center within $\pm 0.5\text{mm}$ as the horizontal.			-	(2)

Note (1) Please refer to the attached drawings for more information of front and back outline dimensions.

Note (2) Connector mounting position

Note (3) Please refer to sec.3.1 for more information of power consumption.

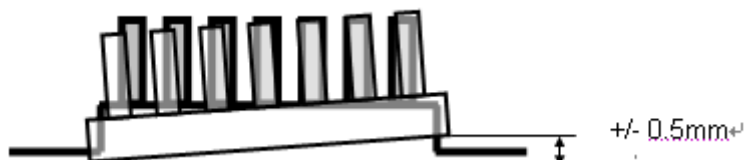

3. ABSOLUTE MAXIMUM RATINGS

3.1 ABSOLUTE RATINGS OF ENVIRONMENT

Item	Symbol	Value		Unit	Note
		Min.	Max.		
Storage Temperature	TST	-20	+60	°C	(1)
Operating Ambient Temperature	TOP	0	+50	°C	(1), (2)

Note (1)

(a) 90 %RH Max. ($T_a \leq 40\text{ }^\circ\text{C}$).

(b) Wet-bulb temperature should be $39\text{ }^\circ\text{C}$ Max. ($T_a > 40\text{ }^\circ\text{C}$).

(c) No condensation.

Note (2) The temperature of panel surface should be $0\text{ }^\circ\text{C}$ min. and $60\text{ }^\circ\text{C}$ max.

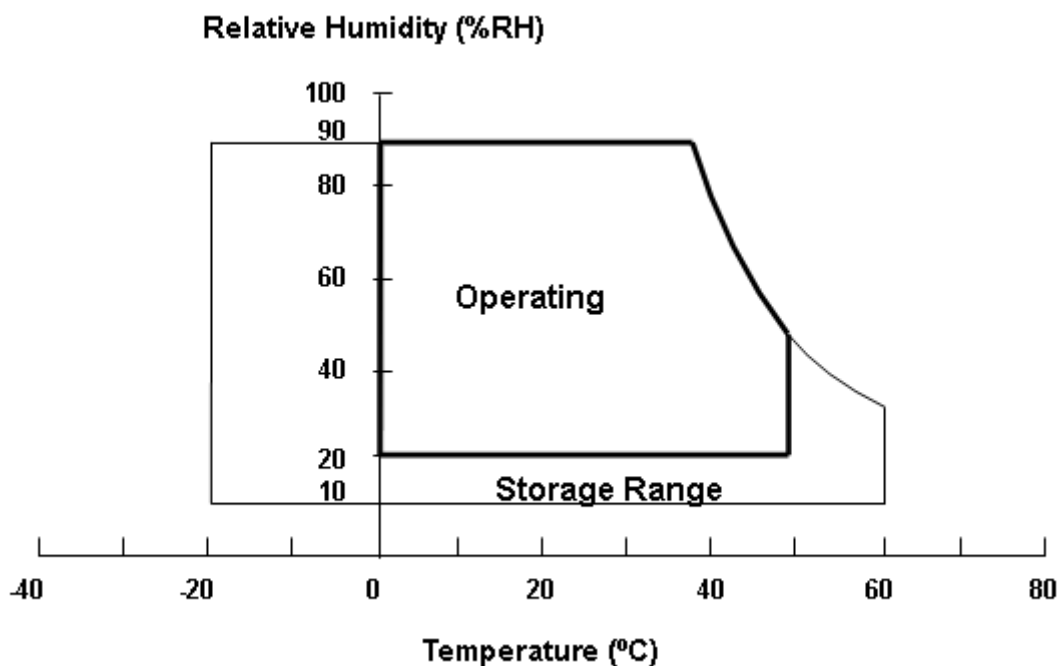

3.2 ELECTRICAL ABSOLUTE RATINGS

3.2.1 TFT LCD MODULE

Item	Symbol	Value		Unit	Note
		Min.	Max.		
Power Supply Voltage	VCCS	-0.3	6.0	V	(1)
Logic Input Voltage	V _{IN}	-0.3	3.6	V	

3.3 ABSOLUTE RATINGS OF ENVIRONMENT (OPEN CELL)

High temperature or humidity may reduce the performance of panel. Please store LCD panel within the specified storage conditions.

Storage Condition: With packing.

Storage temperature range: 25±5 °C.

Storage humidity range: 50±10%RH.

Shelf life: 30days

4. ELECTRICAL SPECIFICATIONS

4.1 FUNCTION BLOCK DIAGRAM

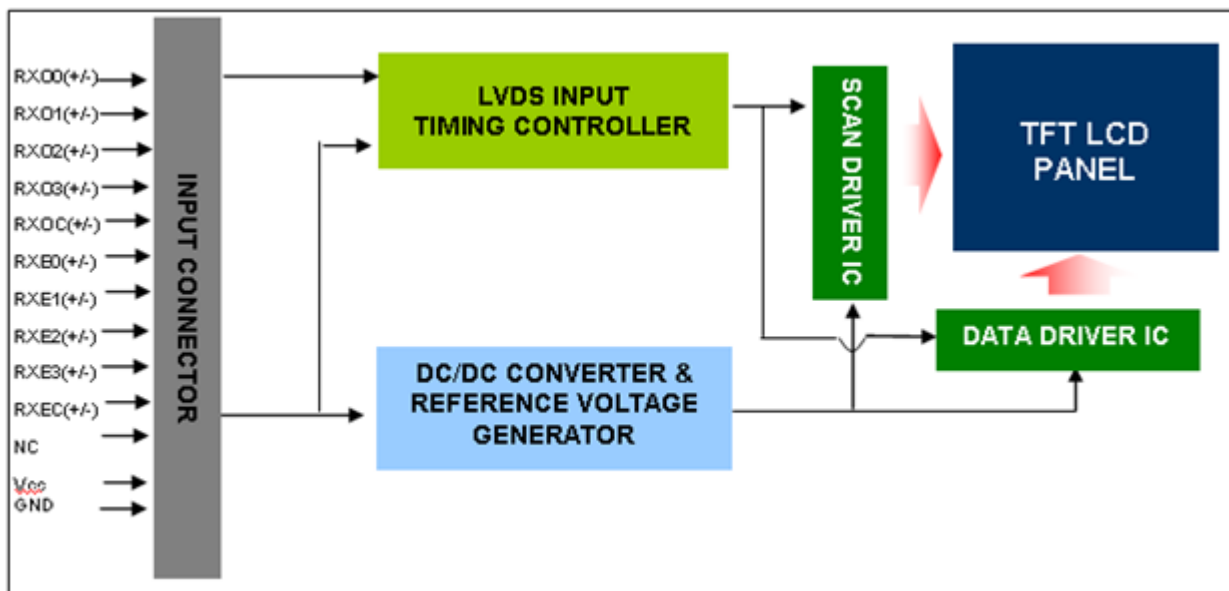

4.2. INTERFACE CONNECTIONS

PIN ASSIGNMENT

Pin	Name	Description
1	RXO0-	Negative LVDS differential data input. Channel O0 (odd)
2	RXO0+	Positive LVDS differential data input. Channel O0 (odd)
3	RXO1-	Negative LVDS differential data input. Channel O1 (odd)
4	RXO1+	Positive LVDS differential data input. Channel O1 (odd)
5	RXO2-	Negative LVDS differential data input. Channel O2 (odd)
6	RXO2+	Positive LVDS differential data input. Channel O2 (odd)
7	GND	Ground
8	RXOC-	Negative LVDS differential clock input. (odd)
9	RXOC+	Positive LVDS differential clock input. (odd)
10	RXO3-	Negative LVDS differential data input. Channel O3(odd)
11	RXO3+	Positive LVDS differential data input. Channel O3 (odd)
12	RXE0-	Negative LVDS differential data input. Channel E0 (even)
13	RXE0+	Positive LVDS differential data input. Channel E0 (even)
14	GND	Ground
15	RXE1-	Negative LVDS differential data input. Channel E1 (even)
16	RXE1+	Positive LVDS differential data input. Channel E1 (even)
17	GND	Ground
18	RXE2-	Negative LVDS differential data input. Channel E2 (even)
19	RXE2+	Positive LVDS differential data input. Channel E2 (even)
20	RXEC-	Negative LVDS differential clock input. (even)
21	RXEC+	Positive LVDS differential clock input. (even)
22	RXE3-	Negative LVDS differential data input. Channel E3 (even)
23	RXE3+	Positive LVDS differential data input. Channel E3 (even)
24	GND	Ground
25	NC	For LCD internal use only, Do not connect
26	NC	For LCD internal use only, Do not connect
27	NC	For LCD internal use only, Do not connect

28	Vcc	+5.0V power supply
29	Vcc	+5.0V power supply
30	Vcc	+5.0V power supply

Connector Information

Item	Description
Manufacturer	FCN/ P-TWO/ Foxconn
Type part number	FCN:WF13-423-3033 P-TWO:187098-30091 Foxconn:GS23301-0321R-7H
Mating housing part number	FI-X30HL(JAE) WM13-011-3050(FCN) P-TWO 27 代(P-TWO)

*Notice: There would be compatible issues, if not using the indicated connectors in the matching list.

Note (1) The first pixel is odd.

Note (2) Input signal of even and odd clock should be the same timing.

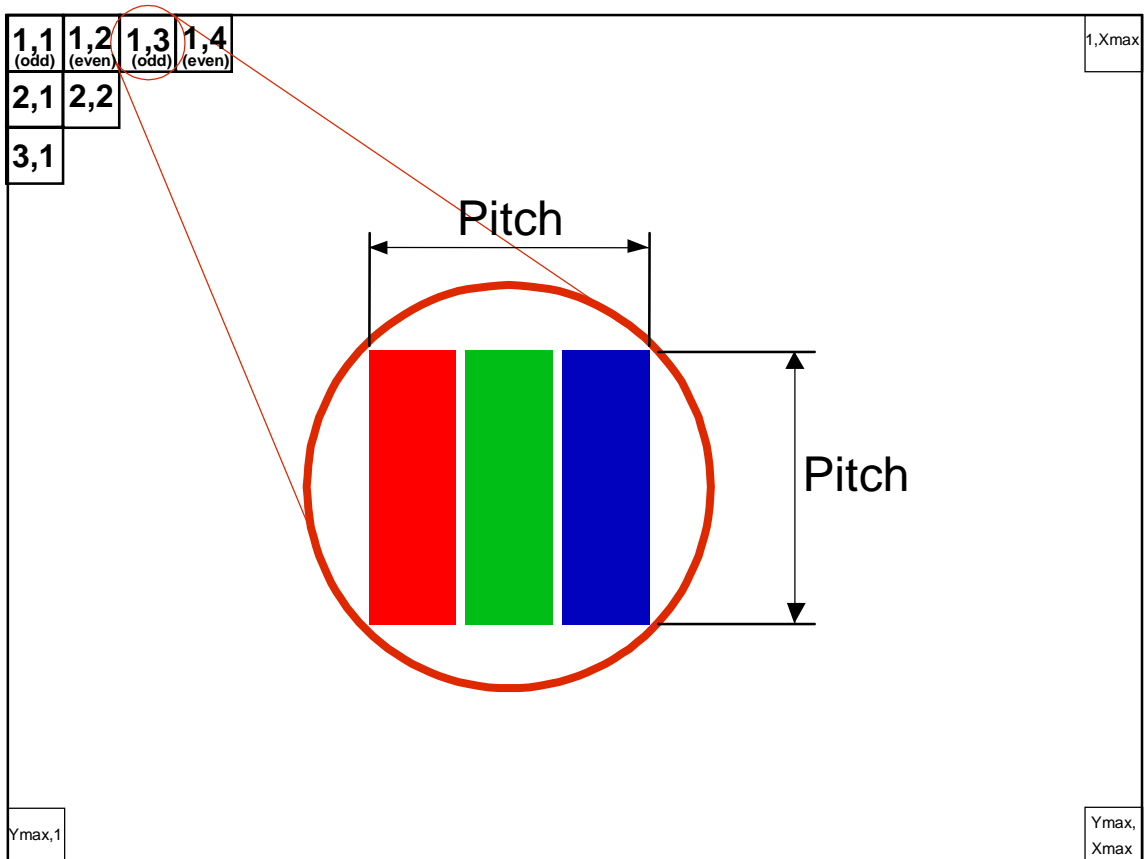

4.3 ELECTRICAL CHARACTERISTICS

Parameter	Symbol	Value			Unit	Note	
		Min.	Typ.	Max.			
Power Supply Voltage	V _{CC}	4.5	5.0	5.5	V	-	
Ripple Voltage	V _{RP}	-	-	300	mV	-	
Rush Current	I _{RUSH}	-	-	3	A	(2)	
Power Supply Current	White	-	0.43	0.48	A	(3)a	
	Black	-	0.83	0.94	A	(3)b	
	Vertical Stripe	-	0.62	0.69	A	(3)c	
Power Consumption	PLCD	-	4.15	4.7	Watt	(4)	
LVDS interface	Differential Input Voltage	V _{ID}	100	-	600	mV	
	Common Input Voltage	V _{CM}	1.0	1.2	1.4	V	
	Differential Input High Threshold Voltage	V _{TH}	-	-	+100	mV	
	Differential Input Low Threshold Voltage	V _{TL}	-100	-	-	mV	

Note (1) The ambient temperature is Ta = 25 ± 2 °C.

Note (2) Measurement Conditions:

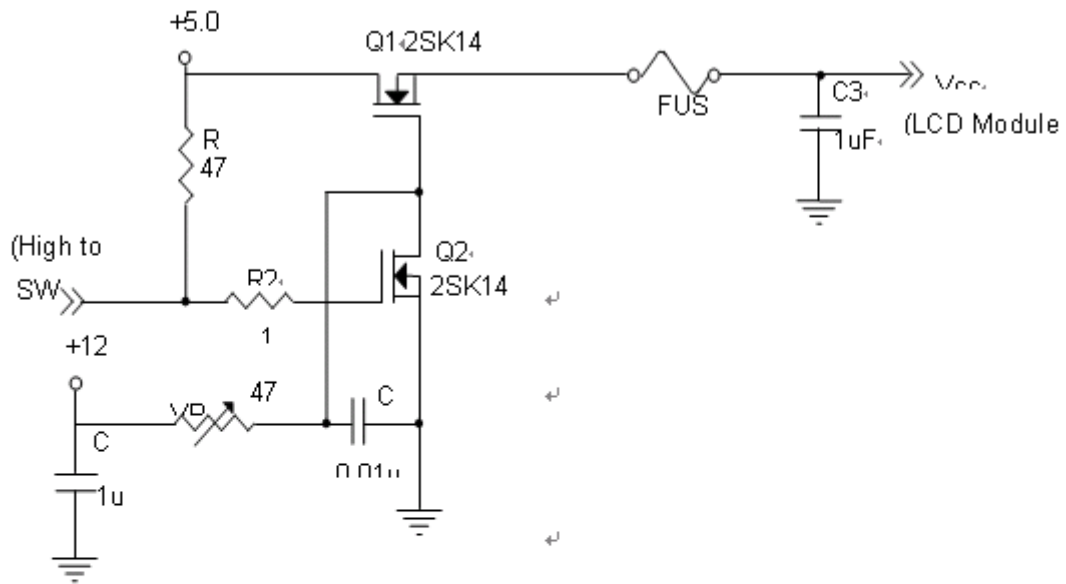

V_{CC} rising time is 470μs

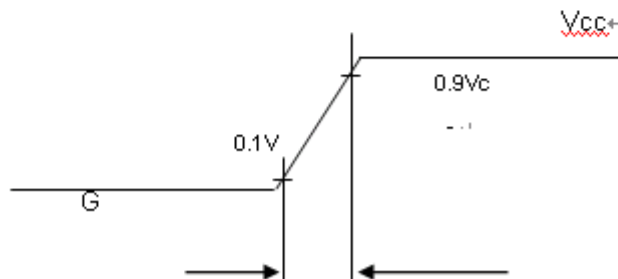

Note (3) The specified power supply current is under the conditions at $V_{cc} = 5.0\text{ V}$, $T_a = 25 \pm 2\text{ }^\circ\text{C}$, $F_v = 75\text{ Hz}$, whereas a power dissipation check pattern below is displayed.

a. White Pattern μ



Active Area μ

b. Black Pattern μ



Active Area μ

c. Vertical Stripe Pattern μ

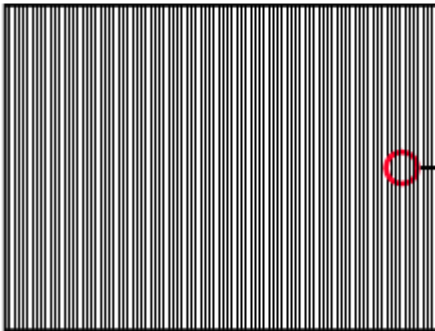

Active Area μ

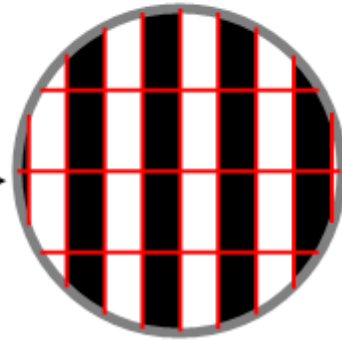

Note (4) The power consumption is specified at the black pattern with the maximum current.

Note (5) The LVDS input characteristics are as follows:

Single-end Signals

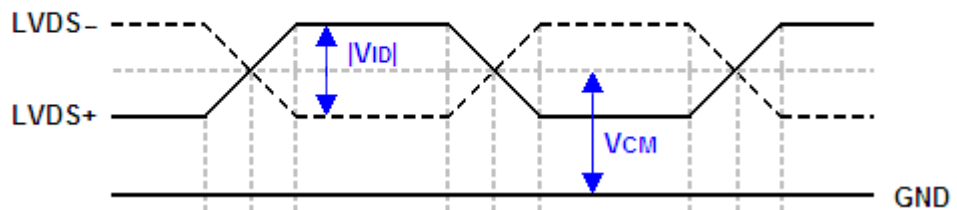

Differential Signal

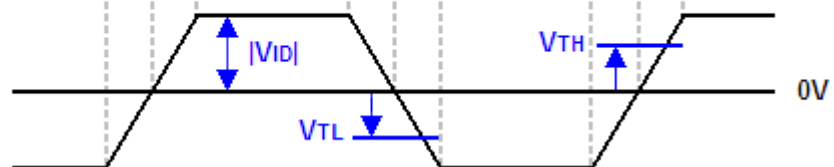

4.4 Vcc POWER DIP CONDITION

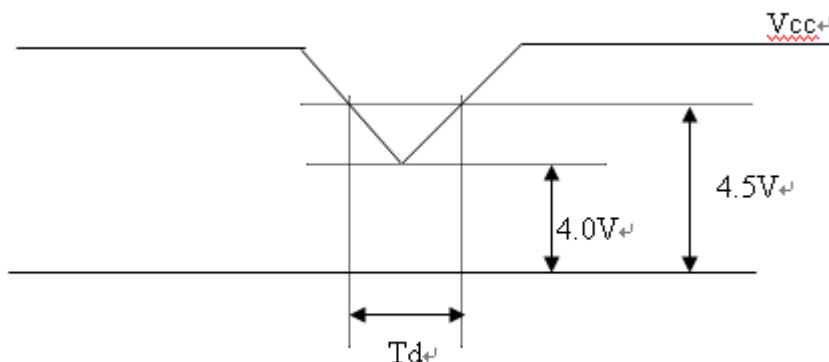

Dip condition: $4.0V \leq V_{cc} \leq 4.5V, T_d \leq 20ms$

4.5 LVDS DATA MAPPING TABLE

LVDS Channel O0	LVDS output	D7	D6	D4	D3	D2	D1	D0
	Data order	OG0	OR5	OR4	OR3	OR2	OR1	OR0
LVDS Channel O1	LVDS output	D18	D15	D14	D13	D12	D9	D8
	Data order	OB1	OB0	OG5	OG4	OG3	OG2	OG1
LVDS Channel O2	LVDS output	D26	D25	D24	D22	D21	D20	D19
	Data order	DE	NA	NA	OB5	OB4	OB3	OB2
LVDS Channel O3	LVDS output	D23	D17	D16	D11	D10	D5	D27
	Data order	NA	OB7	OB6	OG7	OG6	OR7	OR6
LVDS Channel E0	LVDS output	D7	D6	D4	D3	D2	D1	D0
	Data order	EG0	ER5	ER4	ER3	ER2	ER1	ER0
LVDS Channel E1	LVDS output	D18	D15	D14	D13	D12	D9	D8
	Data order	EB1	EB0	EG5	EG4	EG3	EG2	EG1
LVDS Channel E2	LVDS output	D26	D25	D24	D22	D21	D20	D19
	Data order	DE	NA	NA	EB5	EB4	EB3	EB2
LVDS Channel E3	LVDS output	D23	D17	D16	D11	D10	D5	D27
	Data order	NA	EB7	EB6	EG7	EG6	ER7	ER6

4.6 COLOR DATA INPUT ASSIGNMENT

The brightness of each primary color (red, green and blue) is based on the 8-bit gray scale data input for the color. The higher the binary input, the brighter the color. The table below provides the assignment of color versus data input.

Color		Data Signal																							
		Red								Green								Blue							
		R7	R6	R5	R4	R3	R2	R1	R0	R7	R6	G5	G4	G3	G2	G1	G0	R7	R6	B5	B4	B3	B2	B1	B0
Basic Colors	Black	0	0	0	0	0	0	0	0	0	0	0	0	0	0	0	0	0	0	0	0	0	0	0	
	Red	1	1	1	1	1	1	1	1	0	0	0	0	0	0	0	0	0	0	0	0	0	0	0	
	Green	0	0	0	0	0	0	0	0	1	1	1	1	1	1	1	0	0	0	0	0	0	0	0	
	Blue	0	0	0	0	0	0	0	0	0	0	0	0	0	0	0	1	1	1	1	1	1	1	1	
	Cyan	0	0	0	0	0	0	0	0	1	1	1	1	1	1	1	1	1	1	1	1	1	1	1	
	Magenta	1	1	1	1	1	1	1	1	0	0	0	0	0	0	0	1	1	1	1	1	1	1	1	
	Yellow	1	1	1	1	1	1	1	1	1	1	1	1	1	1	1	0	0	0	0	0	0	0	0	
	White	1	1	1	1	1	1	1	1	1	1	1	1	1	1	1	1	1	1	1	1	1	1	1	
Gray Scale Of Red	Red(0) / Dark	0	0	0	0	0	0	0	0	0	0	0	0	0	0	0	0	0	0	0	0	0	0		
	Red(1)	0	0	0	0	0	0	0	1	0	0	0	0	0	0	0	0	0	0	0	0	0	0		
	Red(2)	0	0	0	0	0	0	1	0	0	0	0	0	0	0	0	0	0	0	0	0	0	0		
	⋮	⋮	⋮	⋮	⋮	⋮	⋮	⋮	⋮	⋮	⋮	⋮	⋮	⋮	⋮	⋮	⋮	⋮	⋮	⋮	⋮	⋮			
	⋮	⋮	⋮	⋮	⋮	⋮	⋮	⋮	⋮	⋮	⋮	⋮	⋮	⋮	⋮	⋮	⋮	⋮	⋮	⋮	⋮	⋮			
	⋮	⋮	⋮	⋮	⋮	⋮	⋮	⋮	⋮	⋮	⋮	⋮	⋮	⋮	⋮	⋮	⋮	⋮	⋮	⋮	⋮	⋮			
	Red(253)	1	1	1	1	1	1	0	1	0	0	0	0	0	0	0	0	0	0	0	0	0	0		
	Red(254)	1	1	1	1	1	1	1	0	0	0	0	0	0	0	0	0	0	0	0	0	0	0		
Red(255)	1	1	1	1	1	1	1	1	0	0	0	0	0	0	0	0	0	0	0	0	0	0			
Gray Scale Of Green	Green(0) / Dark	0	0	0	0	0	0	0	0	0	0	0	0	0	0	0	0	0	0	0	0	0	0		
	Green(1)	0	0	0	0	0	0	0	0	0	0	0	0	0	0	1	0	0	0	0	0	0	0		
	Green(2)	0	0	0	0	0	0	0	0	0	0	0	0	0	1	0	0	0	0	0	0	0	0		
	⋮	⋮	⋮	⋮	⋮	⋮	⋮	⋮	⋮	⋮	⋮	⋮	⋮	⋮	⋮	⋮	⋮	⋮	⋮	⋮	⋮	⋮			
	⋮	⋮	⋮	⋮	⋮	⋮	⋮	⋮	⋮	⋮	⋮	⋮	⋮	⋮	⋮	⋮	⋮	⋮	⋮	⋮	⋮	⋮			
	⋮	⋮	⋮	⋮	⋮	⋮	⋮	⋮	⋮	⋮	⋮	⋮	⋮	⋮	⋮	⋮	⋮	⋮	⋮	⋮	⋮	⋮			
	Green(253)	0	0	0	0	0	0	0	1	1	1	1	1	1	0	1	0	0	0	0	0	0	0		
	Green(254)	0	0	0	0	0	0	0	1	1	1	1	1	1	1	0	0	0	0	0	0	0	0		
Green(255)	0	0	0	0	0	0	0	1	1	1	1	1	1	1	1	0	0	0	0	0	0	0			
Gray Scale Of Blue	Blue(0) / Dark	0	0	0	0	0	0	0	0	0	0	0	0	0	0	0	0	0	0	0	0	0	0		
	Blue(1)	0	0	0	0	0	0	0	0	0	0	0	0	0	0	0	0	0	0	0	0	0	1		
	Blue(2)	0	0	0	0	0	0	0	0	0	0	0	0	0	0	0	0	0	0	0	0	0	1		
	⋮	⋮	⋮	⋮	⋮	⋮	⋮	⋮	⋮	⋮	⋮	⋮	⋮	⋮	⋮	⋮	⋮	⋮	⋮	⋮	⋮	⋮			
	⋮	⋮	⋮	⋮	⋮	⋮	⋮	⋮	⋮	⋮	⋮	⋮	⋮	⋮	⋮	⋮	⋮	⋮	⋮	⋮	⋮	⋮			
	⋮	⋮	⋮	⋮	⋮	⋮	⋮	⋮	⋮	⋮	⋮	⋮	⋮	⋮	⋮	⋮	⋮	⋮	⋮	⋮	⋮	⋮			
	Blue(253)	0	0	0	0	0	0	0	0	0	0	0	0	0	0	1	1	1	1	1	1	1	0		
	Blue(254)	0	0	0	0	0	0	0	0	0	0	0	0	0	0	1	1	1	1	1	1	1	0		
Blue(255)	0	0	0	0	0	0	0	0	0	0	0	0	0	0	1	1	1	1	1	1	1	1			

Note (1)0: Low Level Voltage, 1: High Level Voltage

4.7 DISPLAY TIMING SPECIFICATIONS

The input signal timing specifications are shown as the following table and timing diagram.

Signal	Item	Symbol	Min.	Typ.	Max.	Unit	Note
LVDS Clock	Frequency	Fc	42.99	58.67	81.25	MHz	-
	Period	Tc	23.26	17.04	12.31	ns	
	Input cycle to cycle jitter	T _{rcl}	-0.02*TC	-	0.02*TC	ns	(1)
	Input Clock to data skew	TLVCCS	-0.02*TC		0.02*TC	ps	(2)
	Spread spectrum modulation range	F _{ckin_mod}	0.97*FC	-	1.03*TC	MHz	(3)
	Spread spectrum modulation frequency	F _{SSM}			100	KHz	
Vertical Display Term	Frame Rate	Fr	50	60	75	Hz	-
	Total	Tv	905	926	942	Th	Tv=Tvd+Tvb
	Active Display	Tvd		900		Th	-
	Blank	Tvb	5	26	42	Th	-
Horizontal Display Term	Total	Th	950	1056	1150	Tc	Th=Thd+Thb
	Active Display	Thd	-	800	-	Tc	-
	Blank	Thb	150	256	350	Tc	-

Note:(0)Because this module is operated by DE only mode, Hsync and Vsync input signals are ignored.

INPUT SIGNAL TIMING DIAGRAM

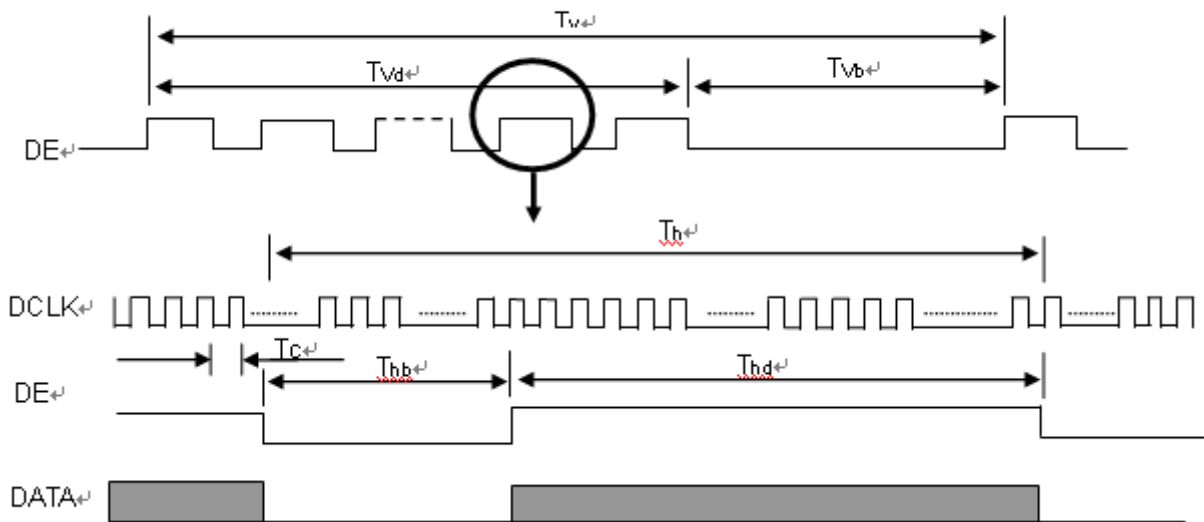

Note (1) The input clock cycle-to-cycle jitter is defined as below figures. $Trcl = |T1 - T1'|$

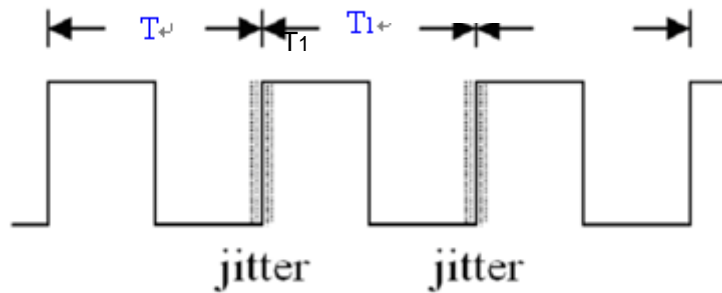

Note (2) The SSCG (Spread spectrum clock generator) is defined as below figures.

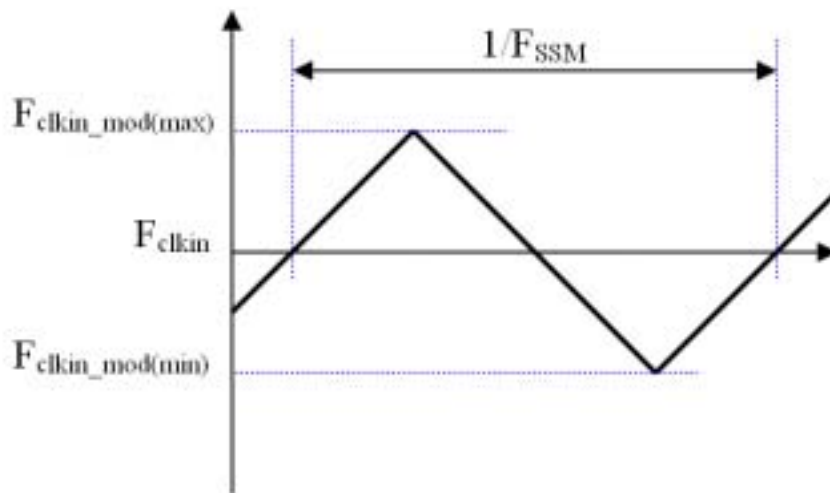

Note (3) Input Clock to data skew is defined as below figures

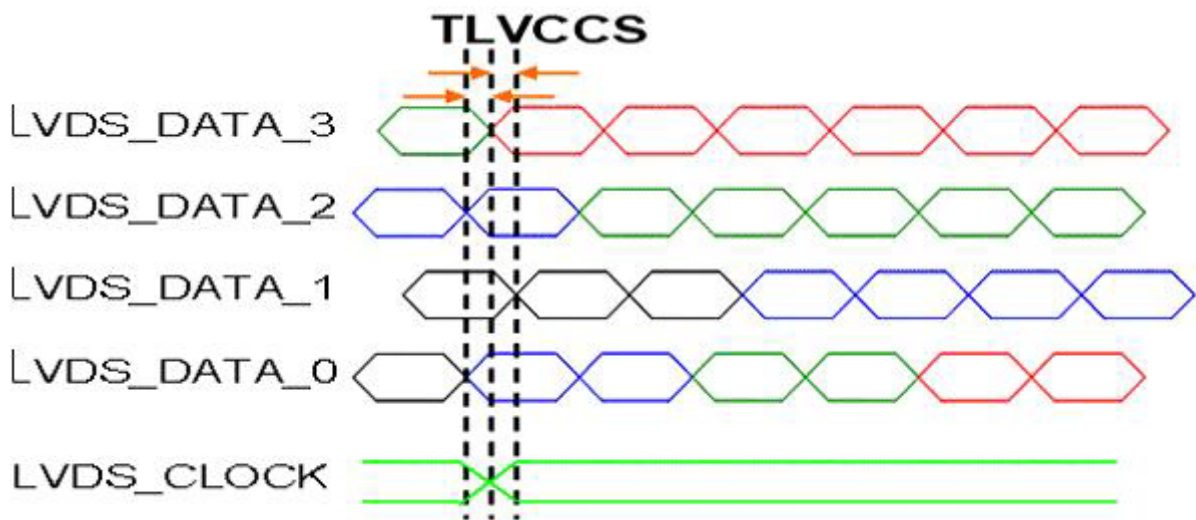

Note (4) The DCLK range at last line of V-blanking should be set in 0 to $Hdisplay/2$

4.8 POWER ON/OFF SEQUENCE

To prevent a latch-up or DC operation of LCD module, the power on/off sequence should be as the diagram below.

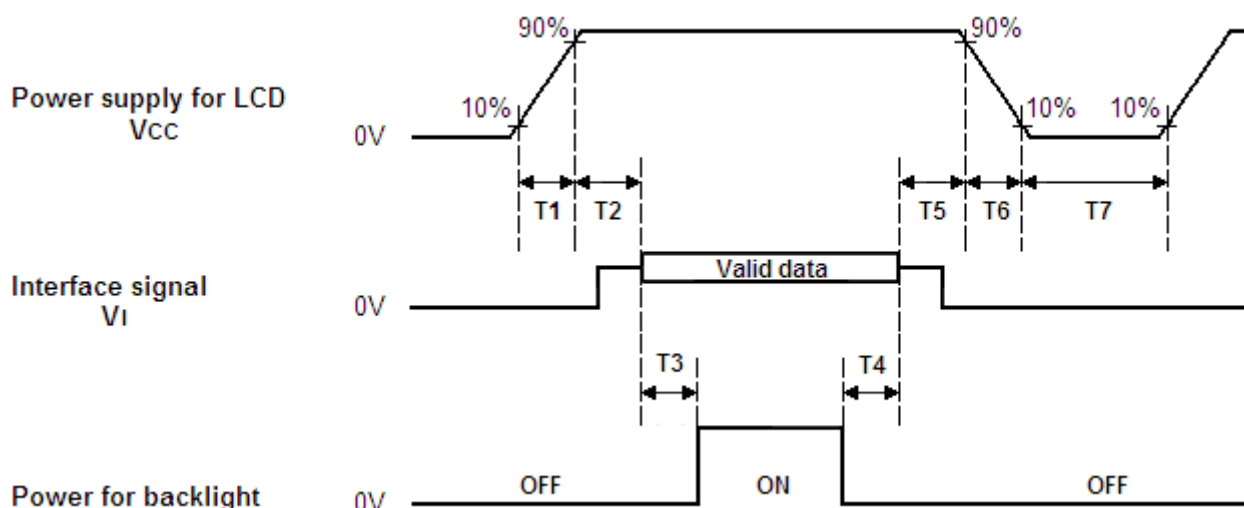

Timing Specifications:

Parameters	Values			Units
	Min	Typ.	Max	
T1	0.5	-	10	ms
T2	0	30	50	ms
T3	200	250	-	ms
T4	100	250	-	ms
T5	0	20	50	ms
T6	0.1	-	100	ms
T7	1000	-	-	ms

Note (1) The supply voltage of the external system for the module input should be the same as the definition of Vcc.

Note (2) When the backlight turns on before the LCD operation of the LCD turns off, the display may momentarily become abnormal screen.

Note (3) In case of VCC = off level, please keep the level of input signals on the low or keep a high impedance.

Note (4) T7 should be measured after the module has been fully discharged between power off and on period.

Note (5) Interface signal shall not be kept at high impedance when the power is on.

Note (6) INNOLUX won't take any responsibility for the products which are damaged by the customers not following the Power Sequence.

Note (7) There might be slight electronic noise when LCD is turned off (even backlight unit is also off). To avoid this symptom, we suggest "Vcc falling timing" to follow "t6 spec".

5. OPTICAL CHARACTERISTICS

5.1 TEST CONDITIONS

Item	Symbol	Value	Unit
Ambient Temperature	Ta	25±2	oC
Ambient Humidity	Ha	50±10	%RH
Supply Voltage	VCC	5	V
Input Signal	According to typical value in "3. ELECTRICAL CHARACTERISTICS"		
Led Light Bar Input Current Per Input Pin	IPIN	65±1.95	mADC
PWM Duty Ratio	D	100	%
LED Light Bar Test Converter	Test OZ9998-8 String T4-8		

5.2 OPTICAL SPECIFICATIONS

The relative measurement methods of optical characteristics are shown as below. The following items should be measured under the test conditions described in 5.1 and stable environment shown in Note (6).

Item	Symbol	Condition	Min.	Typ.	Max.	Unit	Note	
Color Chromaticity (CIE 1931)	Red	Rx	$\theta_x=0^\circ, \theta_y=0^\circ$ CS-2000 R=G=B=255 Gray Scale	Typ - 0.01	0.636	Typ + 0.03	-	(1), (2), (6)
		Ry			0.338			
	Green	Gx			0.311			
		Gy			0.629			
	Blue	Bx			0.159			
		By			0.065			
	White	Wx			0.313			
		Wy			0.329			
Center Transmittance	T%			5.9	-	%	(1), (2), (5)	
Response Time	T _R	$\theta_x=0^\circ, \theta_y=0^\circ$	-	1.5	2.5	ms	(4)	
	T _F		-	3.5	5.5			
White Variation	δW	$\theta_x=0^\circ, \theta_y=0^\circ$ USB2000	75	-	-	%	(6), (7)	
Viewing Angle	Horizontal	x- + x+	CR 10	--	170	--	Deg.	(1), (2), (6)
	Vertical	y- + y+		--	160	--		

Note (0) Light source is the standard light source "C" which is defined by CIE and driving voltages are based on suitable gamma voltages

Note (1) Light source is the BLU, which is supplied by INNOLUX, and driving voltages are based on suitable gamma voltages. White is without signal input and R, G, B are with signal input. SPEC is judged by INNOLUX's golden sample

Note (2) Definition of Viewing Angle (θ_x, θ_y):

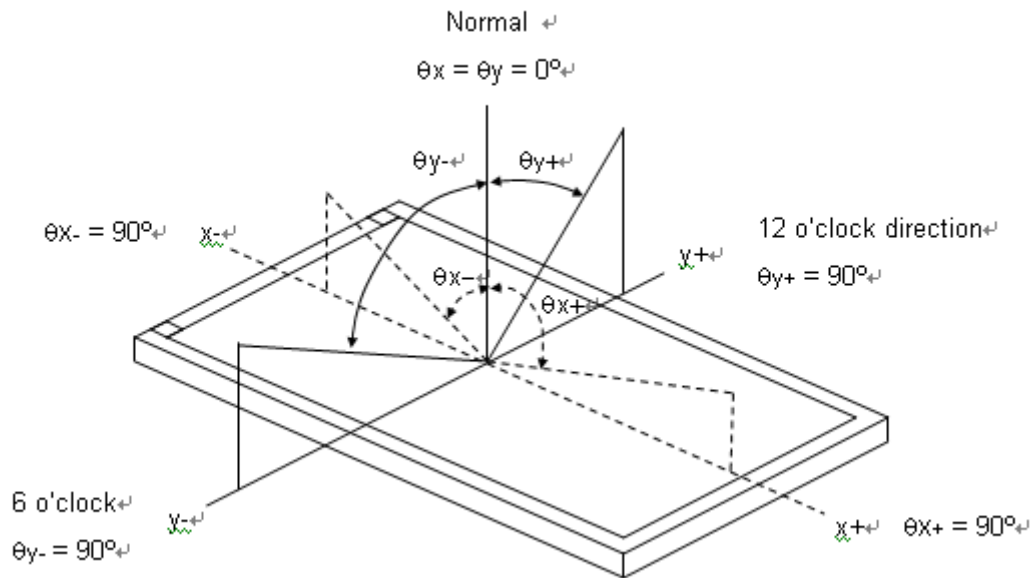

Note (3) : Definition of Contrast Ratio (CR):

The contrast ratio can be calculated by the following expression.

$$\text{Contrast Ratio (CR)} = L_{255} / L_0$$

L255: Luminance of gray level 255

L 0: Luminance of gray level 0

$$CR = CR (5)$$

CR (X) is corresponding to the Contrast Ratio of the point X at Figure in Note (8).

Note (4) Definition of Response Time (TR, TF):

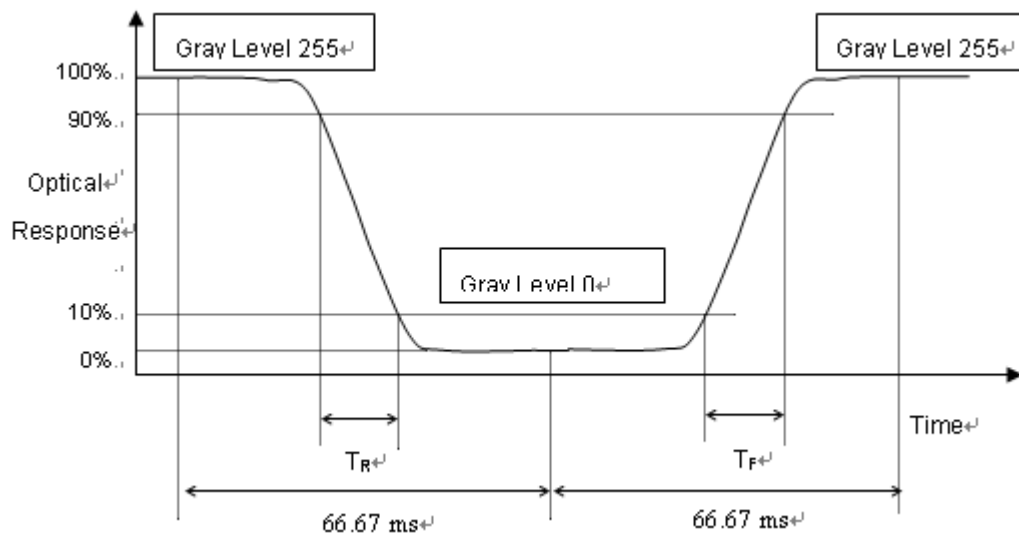

Note (5) Definition of Transmittance (T%):

Module is without signal input.

$$\text{Transmittance} = \frac{\text{Luminance of LCD module } L(X)}{\text{Luminance of backlight}} \times 100\%$$

L (X) and L_{BLU}(X) is corresponding to the luminance of the point X at Figure in Note (8).

Note (6) Measurement Setup:

The LCD module should be stabilized at given temperature for 20minutes to avoid abrupt temperature change during measuring. In order to stabilize the luminance, the measurement should be executed after lighting Backlight for 20minutes in a windless room.

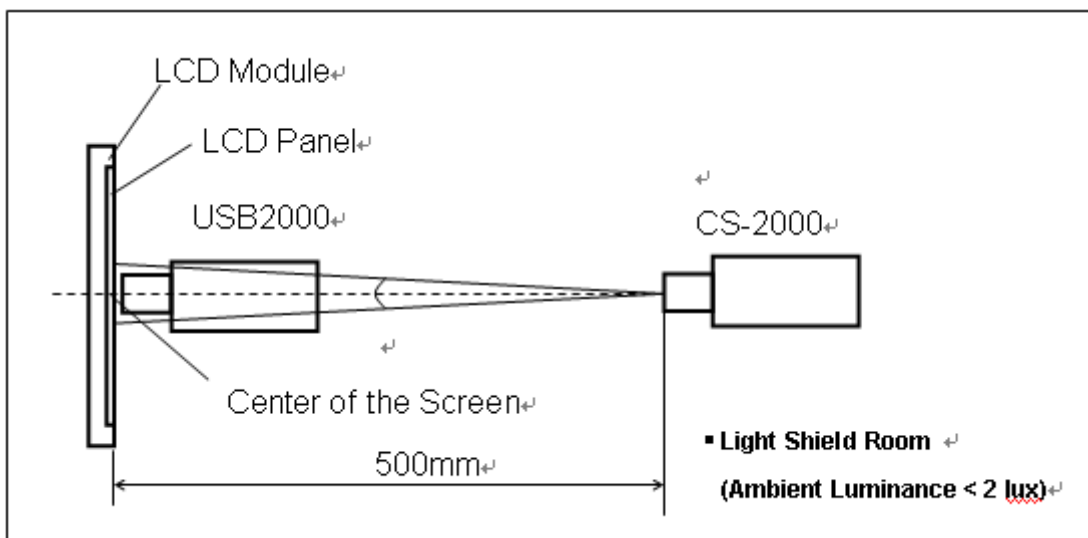

Note (7) : Measurement Setup:

The LCD Panel should be stabilized at given temperature for 30 minutes to avoid abrupt temperature change during measuring. In order to stabilize the luminance, the measurement should be executed after light source "C" for 30 minutes in a windless room.

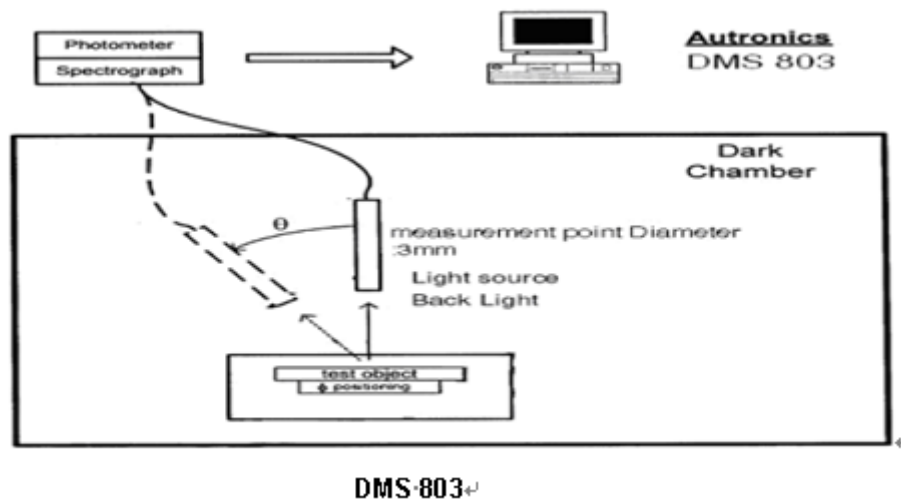

Note (8) : Definition of Transmittance Variation ($\delta T\%$):

Measure the transmittance at 9 points

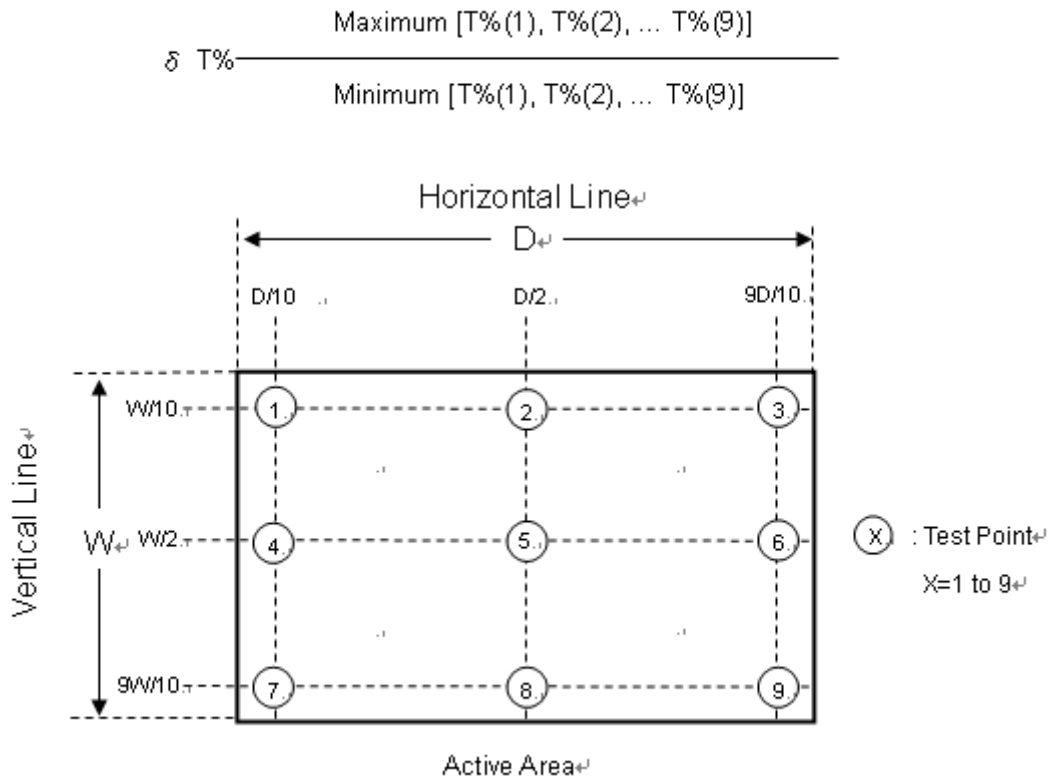

5.3 Flicker Adjustment

Flicker must be finely adjusted after module assembling and aging. Please follow the instructions below.

(1) Adjustment Pattern: Square Inversion checker pattern as follows.

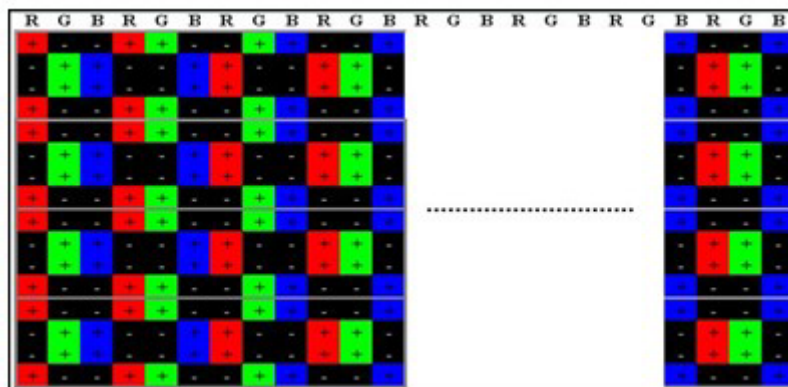

(2) Adjustment Method:

Flicker should be adjusted by turning the volume for flicker adjustment by the ceramic driver. It is adjusted to the point with least flickering of the whole screen. After making it surely overrun at once, it should be adjusted to the optimum point.

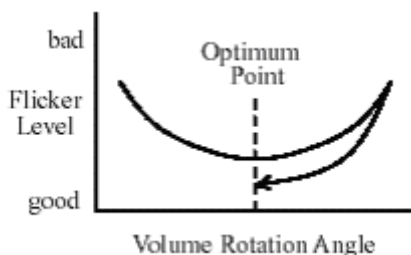

6. RELIABILITY TEST ITEM

Environment test conditions are listed as following table.

Items	Required Condition	Note
Temperature Humidity Bias (THB)	Ta= 50 , 80%RH, 240hours	(1)
High Temperature Operation (HTO)	Ta= 50 , 240hours	
Low Temperature Operation (LTO)	Ta= 0 , 240hours	
High Temperature Storage (HTS)	Ta= 60 , 240hours	
Low Temperature Storage (LTS)	Ta= -20 , 240hours	
Package Vibration Test	ISTA STANDARD 1.14Grms Random, Frequency Range: 1 ~ 200 Hz Top & Bottom: 30 minutes (+Z), 10 min (-Z), Right & Left: 10 minutes (X) Back & Forth 10 minutes (Y)	(2)
Thermal Shock Test (TST)	-20 /30min, 60 / 30min, 100 cycles	(1)
On/Off Test	25 , On/10sec, Off /10sec, 30000 cycles	
Altitude Test	Operation: 10000 ft / 24hours Non-Operation: 30000 ft / 24hours	

Note (1) The tests are done with LCD modules (M195FEG-L20).

Note (2) The test is done with a package shown in Section 8.

7. LABEL

7.1 INNOLUX OPEN CELL LABEL

The barcode nameplate is pasted on each OPEN CELL as illustration for INNOLUX internal control.



Barcode definition:

Serial ID: CM-J5E02-X-X-X-XX-L-XX-L-YMD-NNNN

Code	Meaning	Description
CM	Supplier code	CMI=CM
J5E02	Model number	M195FGE-P02=J5E02
X	Revision code	C1:1, C2:2, ...
X	Source driver IC code	Century=1, CLL=2, Demos=3, Epson=4, Fujitsu=5, Himax=6, Hitachi=7, Hynix=8, LDI=9, Matsushita=A, NEC=B, Novatek=C, OKI=D, Philips=E, Renasas=F, Samsung=G, Sanyo=H, Sharp=I, TI=J, Topro=K, Toshiba=L, Windbond=M, ILITEK=Q, Fiti=Y, None IC =Z
X	Gate driver IC code	IC =Z
XX	Cell location	Tainan, Taiwan=TN
L	Cell line #	1,2,~,9,A,B,~,Y,Z
XX	Module location	Tainan, Taiwan=TN ; Ningbo China=NP
L	Module line #	1,2,~,9,A,B,~,Y,Z
YMD	Year, month, day	Year: 2001=1, 2002=2, 2003=3, 2004=4... Month: 1~12=1, 2, 3, ~, 9, A, B, C Day: 1~31= 1, 2, 3, ~, 9, A, B, C, ~, T, U, V
NNNN	Serial number	Manufacturing sequence of product

8. PACKING

8.1 Packing Information

- (1) 25 LCD Open CELL / 1 Box
- (2) Box dimensions: 555(L) X 405(W) X 163(H) mm
- (3) Weight: approximately: 9.74kg (25 open cells per box)

8.2 CARTON

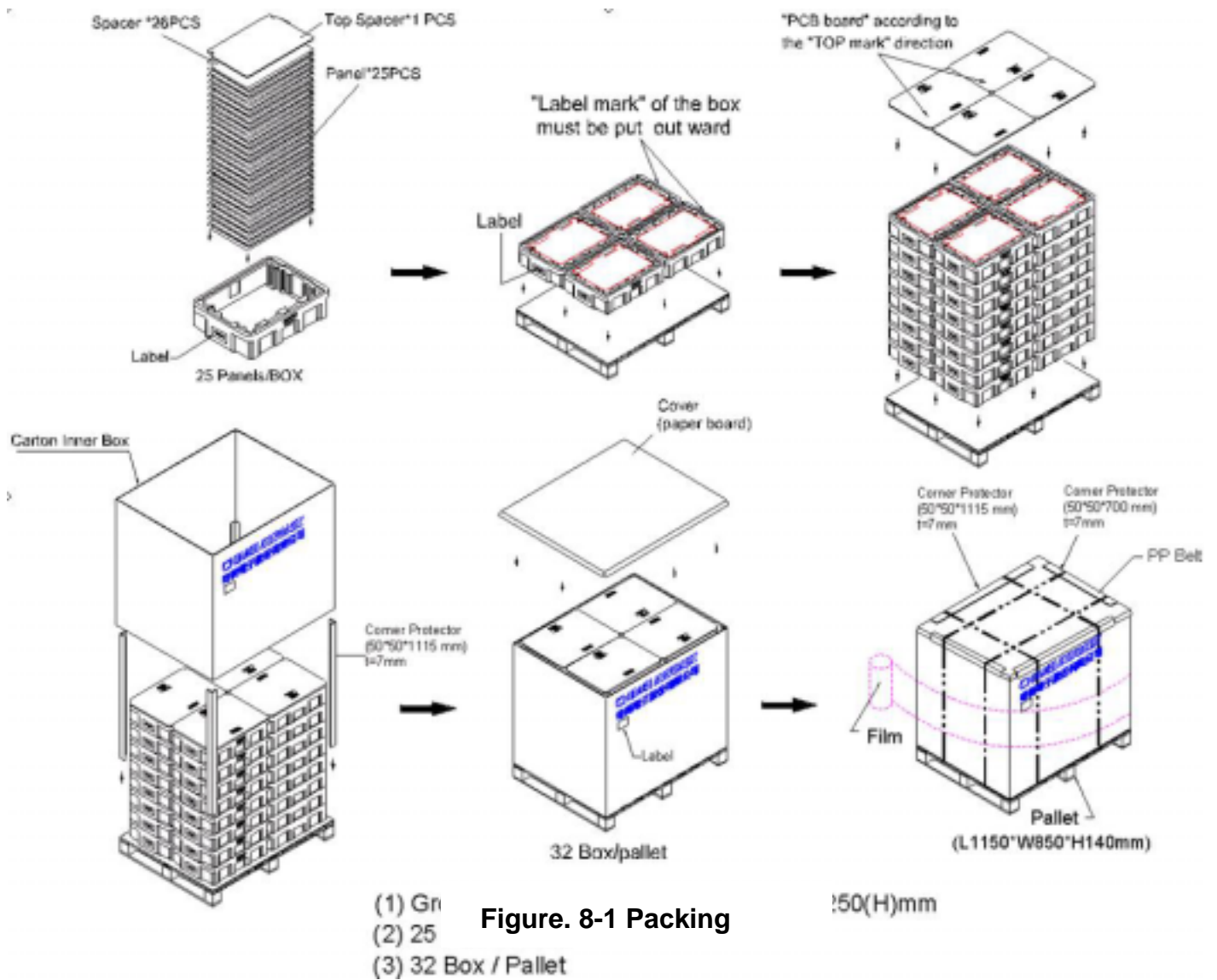

8.3 PALLET

Sea & Land Transportation
(40ft HQ Container)

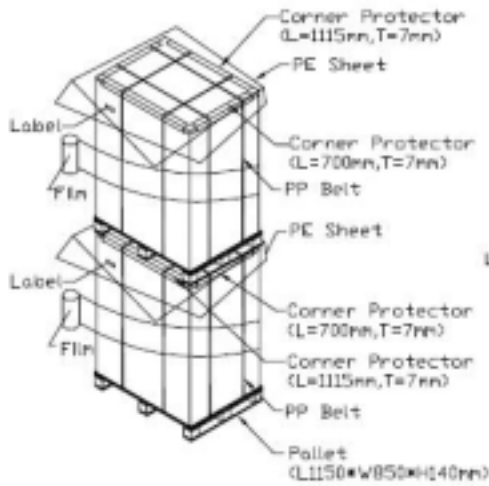

(32 Box / Pallet) + (32 Box / Pallet)

Sea & Land Transportation

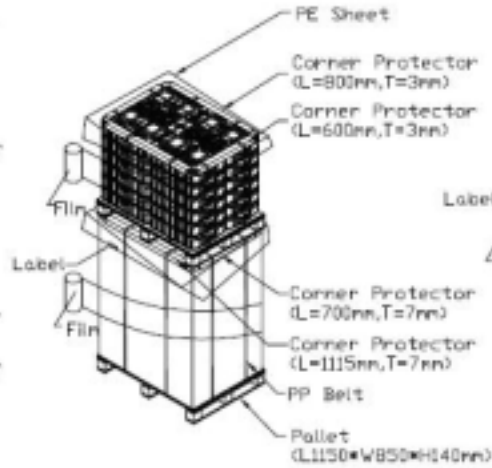

(32 Box / Pallet) + (24 Box / Pallet)

Air Transportation

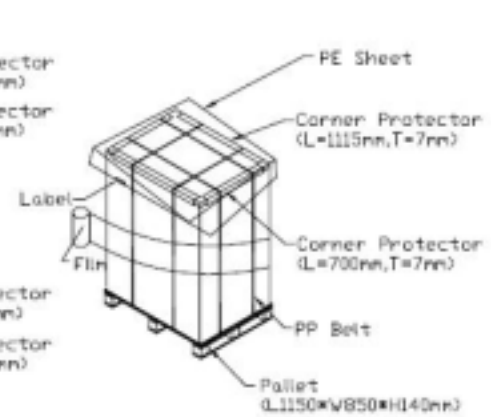

32 Box / Pallet

9. PRECAUTIONS**9.1 ASSEMBLY AND HANDLING PRECAUTIONS**

- (1) Do not apply improper or unbalanced force such as bending or twisting to open cells during assembly.
- (2) It is recommended to assemble or to install an open cell into a customer's product in clean working areas.
The dust and oil may cause electrical short to an open cell or worsen polarizers on an open cell.
- (3) Do not apply pressure or impulse to an open cell to prevent the damage.
- (4) Always follow the correct power-on sequence when an open cell is assembled and turned on. This can prevent the damage and latch-up of the CMOS chips.
- (5) Do not design sharp-pointed structure / parting line / tooling gate on the plastic part of a COF (Chip on film), because the burr will scrape the COF.
- (6) If COF would be bended in assemble process, do not place IC on the bending corner.
- (7) The gap between COF IC and any structure of BLU must be bigger than 2 mm. This can prevent the damage of COF IC.
- (8) The bezel opening must have no burr and be smooth to prevent the surface of an open cell scraped.
- (9) The bezel of a module or a TV set can not contact with force on the surface of an open cell. It might cause light leakage or scrape.
- (10) In the case of no FFC or FPC attached with open cells, customers can refer the FFC / FPC drawing and buy them by self.
- (11) It is important to keep enough clearance between customers' front bezel/backlight and an open cell.
Without enough clearance, the unexpected force during module assembly procedure may damage an open cell.
- (12) Do not plug in or unplug an I/F (interface) connector while an assembled open cell is in operation.
- (13) Use a soft dry cloth without chemicals for cleaning, because the surface of the polarizer is very soft and easily scratched.
- (14) Moisture can easily penetrate into an open cell and may cause the damage during operation.
- (15) When storing open cells as spares for a long time, the following precaution is necessary.
 - (15.1) Do not leave open cells in high temperature and high humidity for a long time. It is highly recommended to store open cells in the temperature range from 0 to 35 °C at normal humidity without condensation.
 - (15.2) Open cells shall be stored in dark place. Do not store open cells in direct sunlight or fluorescent light environment.
- (16) When ambient temperature is lower than 10°C, the display quality might be reduced.
- (17) Unpacking (Cartons/Tray plates) in order to prevent open cells broken:
 - (17.1) Moving tray plates by one operator may cause tray plates bent which may induce open cells broken. Two operators carry one carton with their two hands. Do not throw cartons/tray plates, avoid any impact on cartons/tray plates, and put down & pile cartons/tray plates gently.

- (17.2) A tray plate handled with unbalanced force may cause an open cell damaged. Trays should be completely put on a flat platform.
- (17.3) To prevent open cells broken, tray plates should be moved one by one from a plastic bag.
- (17.4) Please follow the packing design instruction, such as the maximum number of tray stacking to prevent the deformation of tray plates which may cause open cells broken.
- (17.5) To prevent an open cell broken or a COF damaged on a tray, please follow the instructions below:
 - (17.5.1) Do not peel a polarizer protection film of an open cell off on a tray
 - (17.5.2) Do not install FFC or LVDS cables of an open cell on a tray
 - (17.5.3) Do not press the surface of an open cell on a tray.
 - (17.5.4) Do not pull X-board when an open cell placed on a tray.
- (18) Unpacking (Hard Box) in order to prevent open cells broken:
 - (18.1) Moving hard boxes by one operator may cause hard boxes fell down and open cells broken by abnormal methods. Two operators carry one hard box with their two hands. Do handle hard boxes carefully, such as avoiding impact, putting down, and piling up gently.
 - (18.2) To prevent hard boxes sliding from carts and falling down, hard boxes should be placed on a surface with resistance.
 - (18.3) To prevent an open cell broken or a COF damaged in a hard box, please follow the instructions below:
 - (18.3.1) Do not peel a polarizer protection film of an open cell off in a hard box.
 - (18.3.2) Do not install FFC or LVDS cables of an open cell in a hard box.
 - (18.3.3) Do not press the surface of an open cell in a hard box.
 - (18.3.4) Do not pull X-board when an open cell placed in a hard box.
- (19) Handling – In order to prevent open cells, COFs , and components damaged:
 - (19.1) The forced displacement between open cells and X-board may cause a COF damaged. Use a fixture tool for handling an open cell to avoid X-board vibrating and interfering with other components on a PCBA & a COF.
 - (19.2) To prevent open cells and COFs damaged by taking out from hard boxes, using vacuum jigs to take out open cells horizontally is recommended.
 - (19.3) Improper installation procedure may cause COFs of an open cell over bent which causes damages. As installing an open cell on a backlight or a test jig, place the bottom side of the open cell first on the backlight or the test jig and make sure no interference before fitting the open cell into the backlight/the test jig.
 - (19.4) Handle open cells one by one.
- (20) Avoid any metal or conductive material to contact PCB components, because it could cause electrical damage or defect.

9.2 SAFETY PRECAUTIONS

- (1) If the liquid crystal material leaks from the open cell, it should be kept away from the eyes or mouth. In case of contact with hands, skin or clothes, it has to be washed away thoroughly with soap.
- (2) After the end of life, open cells are not harmful in case of normal operation and storage.

10. OUTLINE DRAWING

