



Approval

TFT LCD Approval Specification

MODEL NO.: M215H1-P01



- CONTENTS -

REVISION HISTORY	-----	3
1. GENERAL DESCRIPTION	-----	4
1.1 OVERVIEW		
1.2 FEATURES		
1.3 APPLICATION		
1.4 GENERAL SPECIFICATIONS		
1.5 MECHANICAL SPECIFICATIONS		
2. ABSOLUTE MAXIMUM RATINGS	-----	6
2.1 ABSOLUTE RATINGS OF ENVIRONMENT (BASE ON CMO MODULE M215H1-L01)		
2.2 ABSOLUTE RATINGS OF ENVIRONMENT (OPEN CELL)		
2.3 ELECTRICAL ABSOLUTE RATINGS (OPEN CELL)		
3. ELECTRICAL CHARACTERISTICS	-----	7
3.1 TFT LCD MODULE		
3.2 V _{cc} POWER DIP CONDITION		
4. BLOCK DIAGRAM	-----	9
4.1 TFT LCD MODULE		
5. INPUT TERMINAL PIN ASSIGNMENT	-----	10
5.1 TFT LCD MODULE		
5.2 LVDS DATA MAPPING TABLE		
5.3 COLOR DATA INPUT ASSIGNMENT		
6. INTERFACE TIMING	-----	13
6.1 INPUT SIGNAL TIMING SPECIFICATIONS		
6.2 POWER ON/OFF SEQUENCE		
7. OPTICAL CHARACTERISTICS	-----	16
7.1 TEST CONDITIONS		
7.2 OPTICAL SPECIFICATIONS		
7.3 FLICKER ADJUSTMENT		
8. PACKAGING	-----	20
8.1 PACKING SPECIFICATIONS		
8.2 PACKING METHOD		
9. DEFINITION OF LABELS	-----	21
9.1 OPEN CELL LABEL		
9.2 CARTON LABEL		
10. RELIABILITY TEST	-----	22
11. PRECAUTIONS	-----	23
11.1 ASSEMBLY AND HANDLING PRECAUTIONS		
11.2 SAFETY PRECAUTIONS		
11.3 OTHER		
12. MECHANICAL DRAWING	-----	24

REVISION HISTORY

Version	Date	Section	Description
Ver 2.0	Sep, 17, 09'	All	M215H1-P01 Approval Specifications was first issued.
Ver 2.1	Oct, 22, 09'	1.5	Modified weight (Column "Typ." and "Max.")
Ver 2.2	Nov, 17, 09'	5.1	Added aging mode pin and input voltage.
		6.1	Added Note(3).
Ver 2.3	Feb, 12, 10'	12	Add Cell tolerance

1. GENERAL DESCRIPTION

1.1 OVERVIEW

The M215H1-P01 is a 21.5" wide TFT LCD cell with driver ICs and a 30-pin 2ch-LVDS circuit board. The product supports 1920 x 1080 Full HD (16:9 wide screen) mode. The backlight unit is not built in.

1.2 FEATURES

- Super wide viewing angle
- High contrast ratio
- Response time 5ms.
- Full HD (1920 x 1080 pixels) resolution
- DE (Data Enable) only mode.
- LVDS (Low Voltage Differential Signaling) interface.
- RoHS compliance.

1.3 APPLICATION

- TFT LCD Monitor
- TFT LCD TV

1.4 GENERAL SPECIFICATIONS

Item	Specification	Unit	Note
Diagonal Size	21.53	inch	-
Active Area	476.64 (H) x 268.11 (V)	mm	(1)
Driver Element	a-si TFT active matrix	-	-
Pixel Number	1920 x R.G.B. x 1080	pixel	-
Pixel Pitch	0.248(H) x 0.248(V)	mm	-
Pixel Arrangement	RGB vertical stripe	-	-
Display Colors	16.7 millions	color	-
Transmissive Mode	Normally White	-	-
Surface Treatment	Hard coating (3H), AG (Haze 25%)	-	-
Power Consumption	5.3	Watt	(3)

1.5 MECHANICAL SPECIFICATIONS

Item	Min.	Typ.	Max.	Unit	Note
Weight	-	590	610	g	-
I/F connector mounting position	The mounting inclination of the connector makes the screen center within $\pm 0.5\text{mm}$ as the horizontal.			-	(2)

Note (1) Please refer to the attached drawings for more information of front and back outline dimensions.

Note (2) Connector mounting position

Note (3) Please refer to sec.3.1 for more information of power consumption.

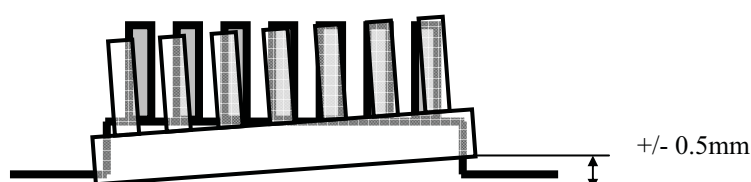



Approval

2. ABSOLUTE MAXIMUM RATINGS

2.1 ABSOLUTE RATINGS OF ENVIRONMENT (BASED ON CMO MODULE M215H1-L01)

Item	Symbol	Value		Unit	Note
		Min.	Max.		
Storage Temperature	T_{ST}	-20	+60	°C	(1)
Operating Ambient Temperature	T_{OP}	0	+50	°C	(1), (2)

2.2 ABSOLUTE RATINGS OF ENVIRONMENT (OPEN CELL)

High temperature or humidity may reduce the performance of panel. Please store LCD panel within the specified storage conditions.

Storage Condition: With packing.

Storage temperature range: 25±5 °C.

Storage humidity range: 50±10%RH.

Shelf life: 30days

2.3 ELECTRICAL ABSOLUTE RATINGS (OPEN CELL)

Item	Symbol	Value		Unit	Note
		Min	Max		
Power Supply Voltage	V _{CC}	-0.3	+6.0	V	(1)

Note (1) Permanent damage might occur if the module is operated at conditions exceeding the maximum values.

3. ELECTRICAL CHARACTERISTICS

3.1 TFT LCD OPEN CELL

 $T_a = 25 \pm 2 \text{ }^\circ\text{C}$

Parameter	Symbol	Value			Unit	Note
		Min.	Typ.	Max.		
Power Supply Voltage	V _{CC}	4.5	5.0	5.5	V	-
Ripple Voltage	V _{RP}	-	-	300	mV(p-p)	-
Power On Rush Current	I _{RUSH}	-	-	3	A	(2)
Power Supply Current	White	-	0.51	0.61	A	(3)a
	Black	-	1.05	1.26	A	(3)b
	Vertical Stripe	-	1.06	1.26	A	(3)c
Power Consumption	P _{LCD}	-	5.3	6.3	Watt	(4)
LVDS differential input voltage	V _{id}	100	-	600	mV	-
LVDS common input voltage	V _{ic}	1.0	1.2	1.4	V	-

Note (1) The product should be always operated within above ranges.

Note (2) Power On Rush Current Measurement Conditions: (must follow power sequence)

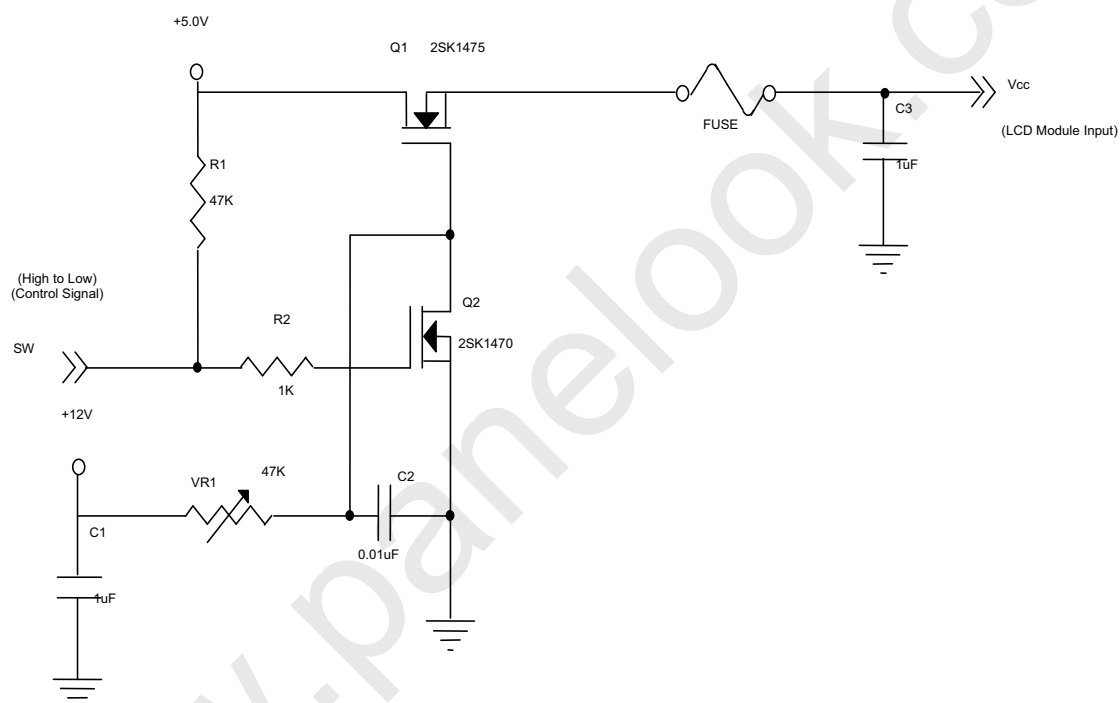

Vcc rising time is 470μs

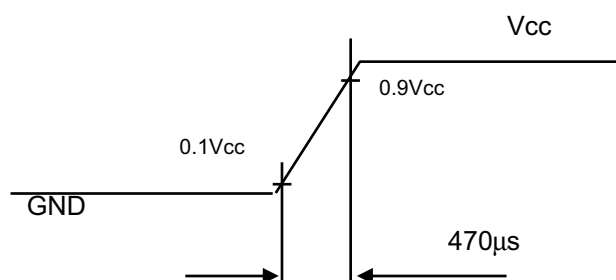

Note (3) The specified power supply current is under the conditions at $V_{cc} = 5.0\text{ V}$, $T_a = 25 \pm 2\text{ }^\circ\text{C}$, $f_v = 60$ Hz, whereas a power dissipation check pattern below is displayed.

a. White Pattern



Active Area

b. Black Pattern

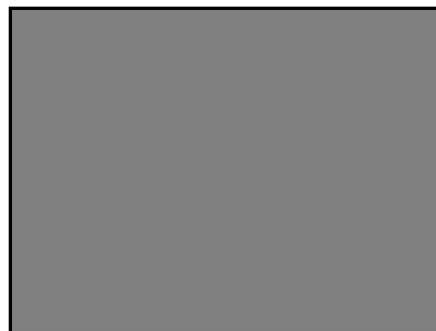

Active Area

c. Vertical Stripe Pattern

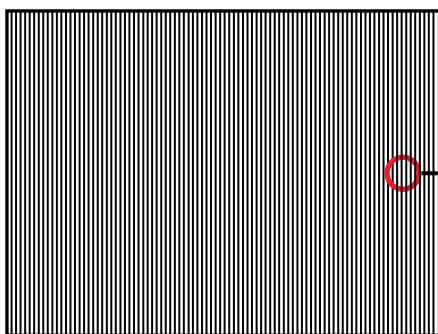

Active Area

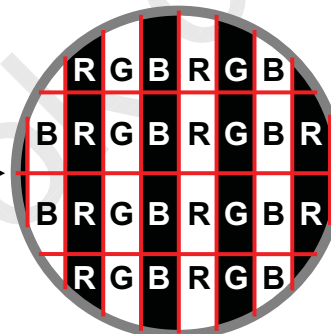

Note (4) The power consumption is specified at the pattern with the maximum current

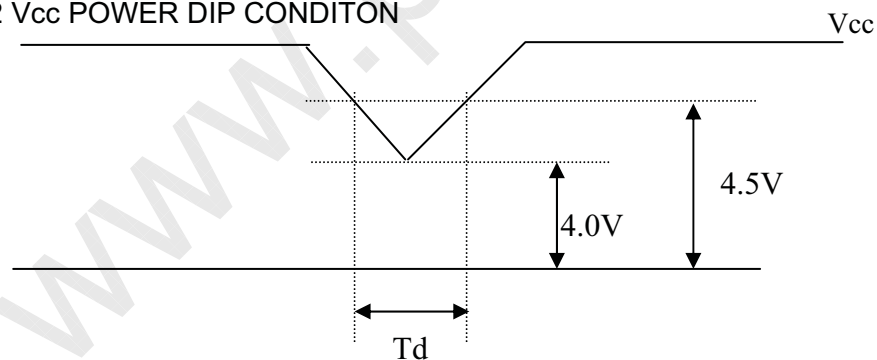
3.2 V_{cc} POWER DIP CONDITION

Dip condition: $4.0\text{ V} \leq V_{cc} \leq 4.5\text{ V}$, $T_d \leq 20\text{ ms}$

4. BLOCK DIAGRAM

4.1 TFT LCD OPEN CELL

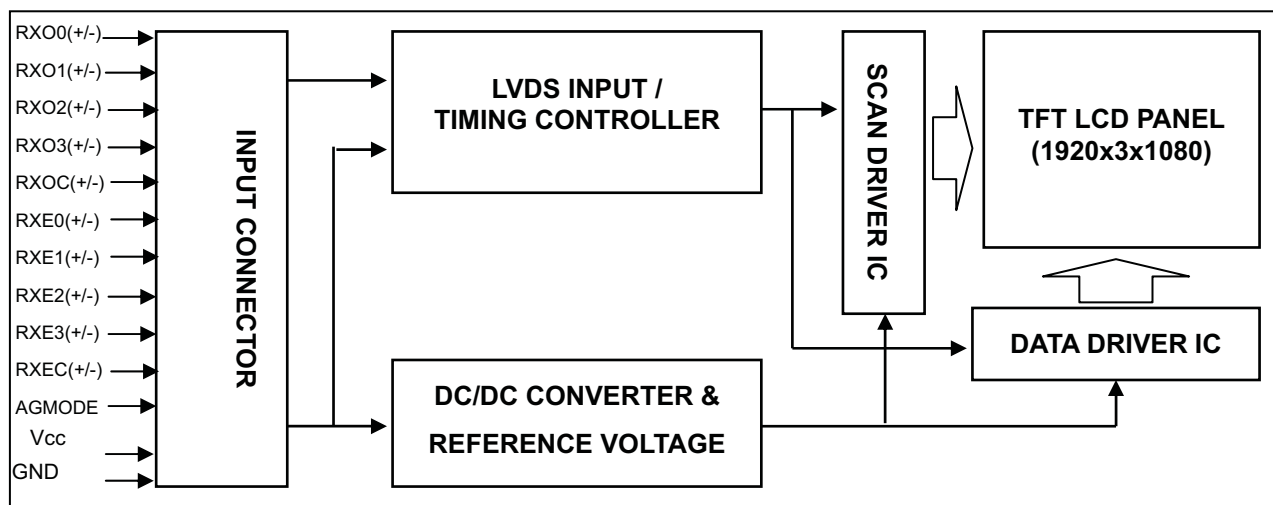

5. INPUT TERMINAL PIN ASSIGNMENT

5.1 TFT LCD OPEN CELL

Pin	Name	Description
1	RXO0-	Negative LVDS differential data input. Channel O0 (odd)
2	RXO0+	Positive LVDS differential data input. Channel O0 (odd)
3	RXO1-	Negative LVDS differential data input. Channel O1 (odd)
4	RXO1+	Positive LVDS differential data input. Channel O1 (odd)
5	RXO2-	Negative LVDS differential data input. Channel O2 (odd)
6	RXO2+	Positive LVDS differential data input. Channel O2 (odd)
7	GND	Ground
8	RXOC-	Negative LVDS differential clock input. (odd)
9	RXOC+	Positive LVDS differential clock input. (odd)
10	RXO3-	Negative LVDS differential data input. Channel O3(odd)
11	RXO3+	Positive LVDS differential data input. Channel O3 (odd)
12	RXE0-	Negative LVDS differential data input. Channel E0 (even)
13	RXE0+	Positive LVDS differential data input. Channel E0 (even)
14	GND	Ground
15	RXE1-	Negative LVDS differential data input. Channel E1 (even)
16	RXE1+	Positive LVDS differential data input. Channel E1 (even)
17	GND	Ground
18	RXE2-	Negative LVDS differential data input. Channel E2 (even)
19	RXE2+	Positive LVDS differential data input. Channel E2 (even)
20	RXEC-	Negative LVDS differential clock input. (even)
21	RXEC+	Positive LVDS differential clock input. (even)
22	RXE3-	Negative LVDS differential data input. Channel E3 (even)
23	RXE3+	Positive LVDS differential data input. Channel E3 (even)
24	GND	Ground
25	NC	Not connection, this pin should be open.
26	NC	Not connection, this pin should be open.

5.2 LVDS DATA MAPPING TABLE

LVDS Channel O0	LVDS output	D7	D6	D4	D3	D2	D1	D0
	Data order	OG0	OR5	OR4	OR3	OR2	OR1	OR0
LVDS Channel O1	LVDS output	D18	D15	D14	D13	D12	D9	D8
	Data order	OB1	OB0	OG5	OG4	OG3	OG2	OG1
LVDS Channel O2	LVDS output	D26	D25	D24	D22	D21	D20	D19
	Data order	DE	NA	NA	OB5	OB4	OB3	OB2
LVDS Channel O3	LVDS output	D23	D17	D16	D11	D10	D5	D27
	Data order	NA	OB7	OB6	OG7	OG6	OR7	OR6
LVDS Channel E0	LVDS output	D7	D6	D4	D3	D2	D1	D0
	Data order	EG0	ER5	ER4	ER3	ER2	ER1	ER0
LVDS Channel E1	LVDS output	D18	D15	D14	D13	D12	D9	D8
	Data order	EB1	EB0	EG5	EG4	EG3	EG2	EG1
LVDS Channel E2	LVDS output	D26	D25	D24	D22	D21	D20	D19
	Data order	DE	NA	NA	EB5	EB4	EB3	EB2
LVDS Channel E3	LVDS output	D23	D17	D16	D11	D10	D5	D27
	Data order	NA	EB7	EB6	EG7	EG6	ER7	ER6



Approval

5.3 COLOR DATA INPUT ASSIGNMENT

The brightness of each primary color (red, green and blue) is based on the 8-bit gray scale data input for the color. The higher the binary input, the brighter the color. The table below provides the assignment of color versus data input.

Color		Data Signal																							
		Red								Green								Blue							
		R7	R6	R5	R4	R3	R2	R1	R0	G7	G6	G5	G4	G3	G2	G1	G0	B7	B6	B5	B4	B3	B2	B1	B0
Basic Colors	Black	0	0	0	0	0	0	0	0	0	0	0	0	0	0	0	0	0	0	0	0	0	0	0	0
	Red	1	1	1	1	1	1	1	1	0	0	0	0	0	0	0	0	0	0	0	0	0	0	0	0
	Green	0	0	0	0	0	0	0	0	1	1	1	1	1	1	1	1	0	0	0	0	0	0	0	0
	Blue	0	0	0	0	0	0	0	0	0	0	0	0	0	0	0	0	1	1	1	1	1	1	1	1
	Cyan	0	0	0	0	0	0	0	0	1	1	1	1	1	1	1	1	1	1	1	1	1	1	1	1
	Magenta	1	1	1	1	1	1	1	1	0	0	0	0	0	0	0	0	1	1	1	1	1	1	1	1
	Yellow	1	1	1	1	1	1	1	1	1	1	1	1	1	1	1	1	0	0	0	0	0	0	0	0
	White	1	1	1	1	1	1	1	1	1	1	1	1	1	1	1	1	1	1	1	1	1	1	1	1
Gray Scale Of Red	Red(0) / Dark	0	0	0	0	0	0	0	0	0	0	0	0	0	0	0	0	0	0	0	0	0	0	0	0
	Red(1)	0	0	0	0	0	0	0	1	0	0	0	0	0	0	0	0	0	0	0	0	0	0	0	0
	Red(2)	0	0	0	0	0	0	1	0	0	0	0	0	0	0	0	0	0	0	0	0	0	0	0	0
	⋮	⋮	⋮	⋮	⋮	⋮	⋮	⋮	⋮	⋮	⋮	⋮	⋮	⋮	⋮	⋮	⋮	⋮	⋮	⋮	⋮	⋮	⋮	⋮	⋮
	⋮	⋮	⋮	⋮	⋮	⋮	⋮	⋮	⋮	⋮	⋮	⋮	⋮	⋮	⋮	⋮	⋮	⋮	⋮	⋮	⋮	⋮	⋮	⋮	⋮
	Red(253)	1	1	1	1	1	1	0	1	0	0	0	0	0	0	0	0	0	0	0	0	0	0	0	0
	Red(254)	1	1	1	1	1	1	1	0	0	0	0	0	0	0	0	0	0	0	0	0	0	0	0	0
	Red(255)	1	1	1	1	1	1	1	1	0	0	0	0	0	0	0	0	0	0	0	0	0	0	0	0
Gray Scale Of Green	Green(0) / Dark	0	0	0	0	0	0	0	0	0	0	0	0	0	0	0	0	0	0	0	0	0	0	0	0
	Green(1)	0	0	0	0	0	0	0	0	0	0	0	0	0	0	1	0	0	0	0	0	0	0	0	0
	Green(2)	0	0	0	0	0	0	0	0	0	0	0	0	0	1	0	0	0	0	0	0	0	0	0	0
	⋮	⋮	⋮	⋮	⋮	⋮	⋮	⋮	⋮	⋮	⋮	⋮	⋮	⋮	⋮	⋮	⋮	⋮	⋮	⋮	⋮	⋮	⋮	⋮	⋮
	⋮	⋮	⋮	⋮	⋮	⋮	⋮	⋮	⋮	⋮	⋮	⋮	⋮	⋮	⋮	⋮	⋮	⋮	⋮	⋮	⋮	⋮	⋮	⋮	⋮
	Green(253)	0	0	0	0	0	0	0	1	1	1	1	1	1	1	0	1	0	0	0	0	0	0	0	0
	Green(254)	0	0	0	0	0	0	0	1	1	1	1	1	1	1	0	0	0	0	0	0	0	0	0	0
	Green(255)	0	0	0	0	0	0	0	1	1	1	1	1	1	1	1	0	0	0	0	0	0	0	0	0
Gray Scale Of Blue	Blue(0) / Dark	0	0	0	0	0	0	0	0	0	0	0	0	0	0	0	0	0	0	0	0	0	0	0	0
	Blue(1)	0	0	0	0	0	0	0	0	0	0	0	0	0	0	0	0	0	0	0	0	0	0	0	1
	Blue(2)	0	0	0	0	0	0	0	0	0	0	0	0	0	0	0	0	0	0	0	0	0	0	1	0
	⋮	⋮	⋮	⋮	⋮	⋮	⋮	⋮	⋮	⋮	⋮	⋮	⋮	⋮	⋮	⋮	⋮	⋮	⋮	⋮	⋮	⋮	⋮	⋮	⋮
	⋮	⋮	⋮	⋮	⋮	⋮	⋮	⋮	⋮	⋮	⋮	⋮	⋮	⋮	⋮	⋮	⋮	⋮	⋮	⋮	⋮	⋮	⋮	⋮	⋮
	Blue(253)	0	0	0	0	0	0	0	0	0	0	0	0	0	0	0	1	1	1	1	1	1	1	0	1
	Blue(254)	0	0	0	0	0	0	0	0	0	0	0	0	0	0	0	1	1	1	1	1	1	1	1	0
	Blue(255)	0	0	0	0	0	0	0	0	0	0	0	0	0	0	0	1	1	1	1	1	1	1	1	1

Note (1) 0: Low Level Voltage, 1: High Level Voltage

6. INTERFACE TIMING

6.1 INPUT SIGNAL TIMING SPECIFICATIONS

The input signal timing specifications are shown as the following table and timing diagram.

Signal	Item	Symbol	Min.	Typ.	Max.	Unit	Note
LVDS Clock	Frequency	F_c	58.54	74.25	97.98	MHz	-
	Period	T_c	-	13.47	-	ns	-
	Input cycle to cycle jitter	T_{rcj}	-	-	200	ps	(1)
	Spread spectrum modulation range	F_{clkin_mod}	$F_{clkin}-2\%$	-	$F_{clkin}+2\%$	MHz	(2)
	Spread spectrum modulation frequency	F_{SSM}	-	-	200	KHz	
	High Time	T_{ch}	-	4/7	-	Tc	-
	Low Time	T_{cl}	-	3/7	-	Tc	-
LVDS Data	Setup Time	T_{lvs}	600	-	-	ps	-
	Hold Time	T_{lvh}	600	-	-	ps	-
Vertical Active Display Term	Frame Rate	F_r	50	60	75	Hz	-
	Total	T_v	1115	1125	1136	Th	$T_v=T_{vd}+T_{vb}$
	Display	T_{vd}	1080	1080	1080	Th	-
	Blank	T_{vb}	T_v-T_{vd}	45	T_v-T_{vd}	Th	-
Horizontal Active Display Term	Total	T_h	1050	1100	1150	Tc	$T_h=T_{hd}+T_{hb}$
	Display	T_{hd}	960	960	960	Tc	-
	Blank	T_{hb}	T_h-T_{hd}	140	T_h-T_{hd}	Tc	-

Note (0) Because this product is operated by DE only mode, Hsync and Vsync input signals should be set to low logic level or ground. Otherwise, this product would operate abnormally.

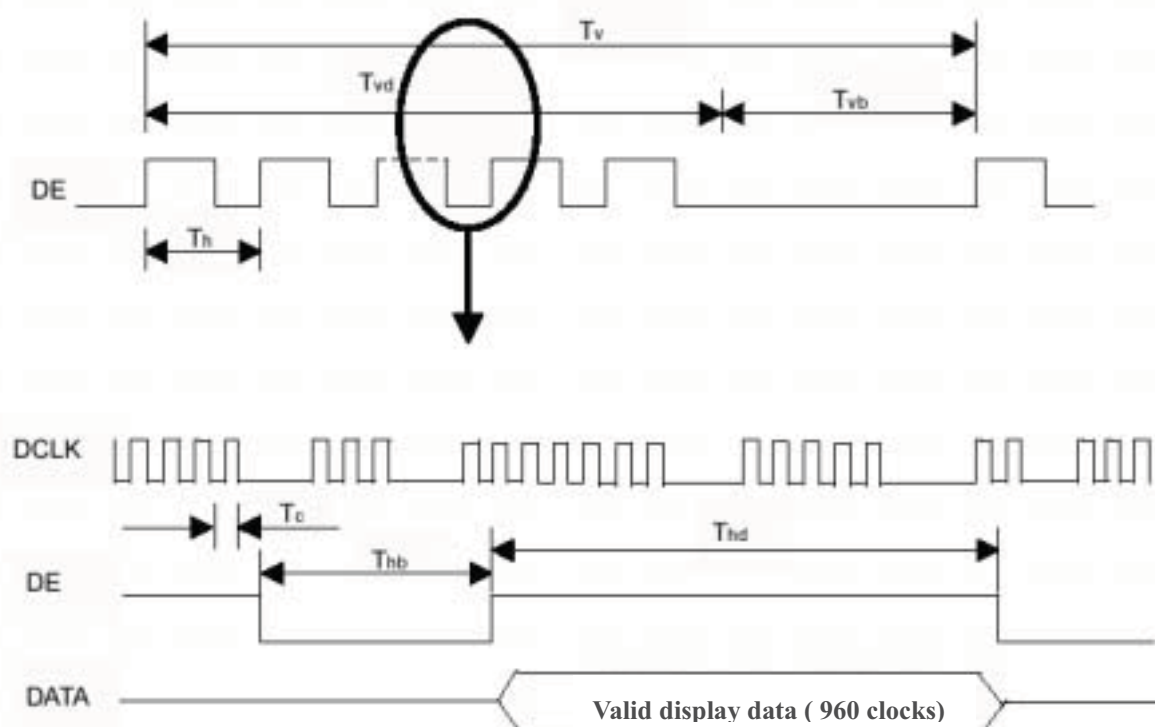
INPUT SIGNAL TIMING DIAGRAM



Approval

Note (1) The input clock cycle-to-cycle jitter is defined as below figures. $Trcl = |T_1 - T_1|$

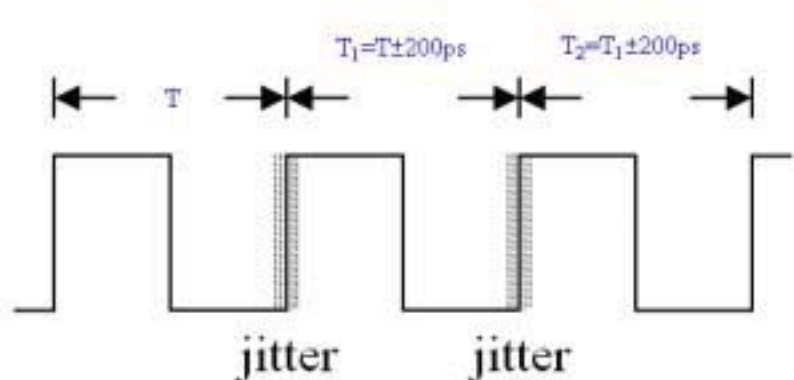

Note (2) The SSCG (Spread spectrum clock generator) is defined as below figures.

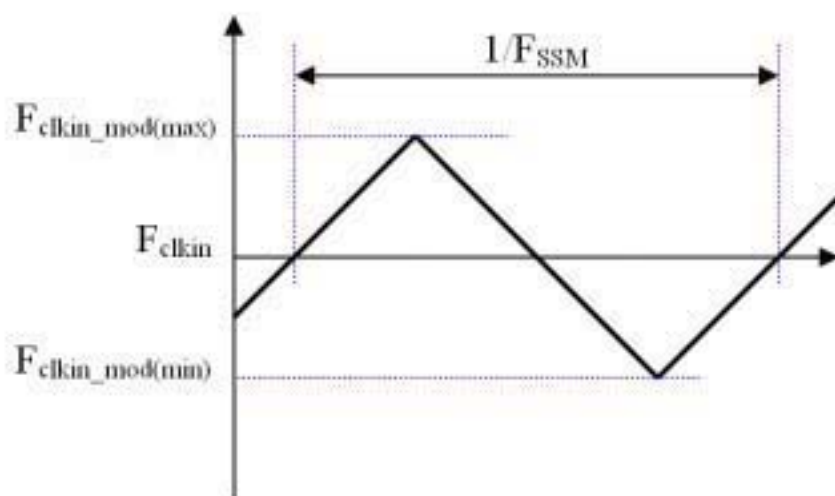

Note (3) The LVDS timing diagram and setup/hold time is defined and showing as the following figures.

LVDS RECEIVER INTERFACE TIMING DIAGRAM

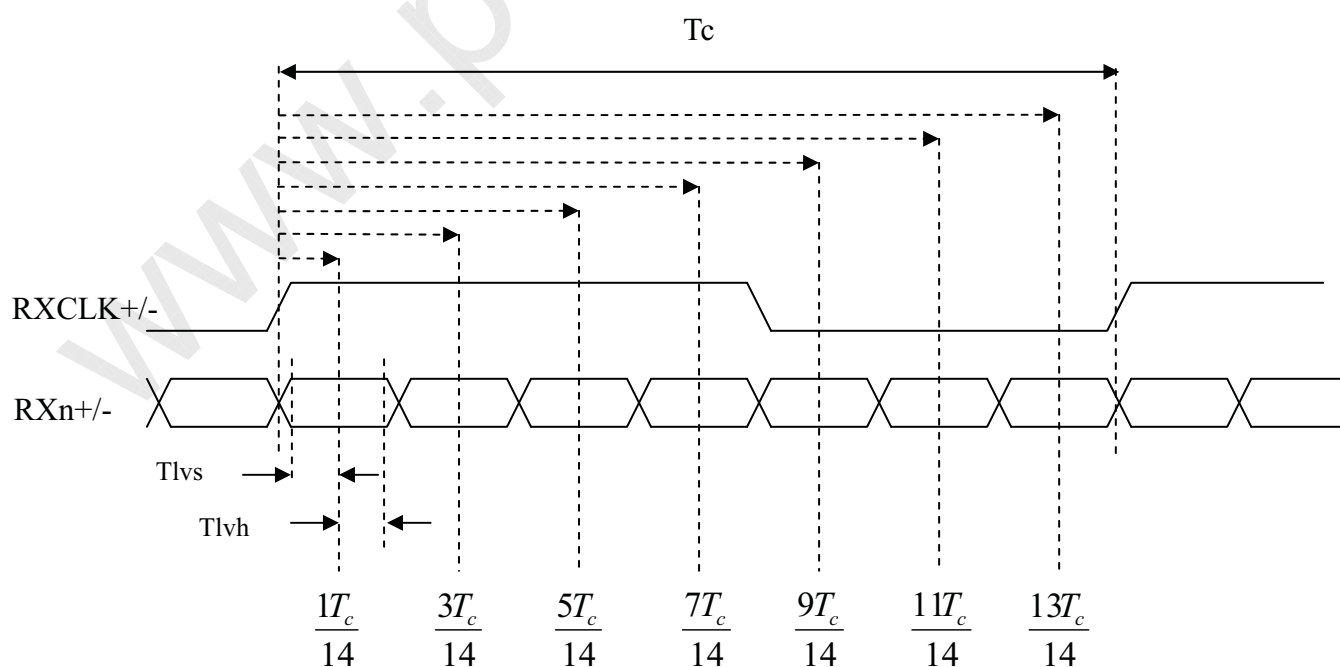



Approval

www.panelook.com

7. OPTICAL CHARACTERISTICS

7.1 TEST CONDITIONS

Item	Symbol	Value	Unit
Ambient Temperature	Ta	25±2	°C
Ambient Humidity	Ha	50±10	%RH
Supply Voltage	V _{CC}	5.0	V
Input Signal	According to typical value in "3. ELECTRICAL CHARACTERISTICS"		
Inverter Current	I _L	7.0±0.5	mA
Inverter Driving Frequency	F _L	55±5	KHz
Inverter	Logah MIT70070.50		

7.2 OPTICAL SPECIFICATIONS

The relative measurement methods of optical characteristics are shown in 7.2. The following items should be measured under the test conditions described in 7.1 and stable environment shown in Note (6).

Item	Symbol	Condition	Min.	Typ.	Max.	Unit	Note	
Color Chromaticity	Red	$\theta_x=0^\circ, \theta_y=0^\circ$ CS-1000T Standard light source "C"	Typ - -0.03	0.657	Typ + 0.03	-	(0),(6)	
				0.330				
	Green			0.282				
				0.592				
	Blue			0.146				
				0.104				
	White			0.325				
				0.367				
Center Transmittance	T%	$\theta_x=0^\circ, \theta_y=0^\circ$	5.8	6.5	-	%	(1), (5)	
Contrast Ratio	CR	CS-1000T, CMO BLU	700	1000	-	-	(1), (3)	
Response Time	T _R	$\theta_x=0^\circ, \theta_y=0^\circ$	-	1.3	2.2	ms	(4)	
	T _F			3.7	5.8	ms		
Transmittance uniformity	δT	$\theta_x=0^\circ, \theta_y=0^\circ$ CS-1000T	-	1.1	1.3	-	(1), (7)	
Viewing Angle	Horizontal	CR≥10 BM-5A	75	85	-	Deg.	(1), (2) (6)	
				75	85			-
	Vertical			70	80			-
				70	80			-

Note (2) Definition of Viewing Angle (θ_x, θ_y):

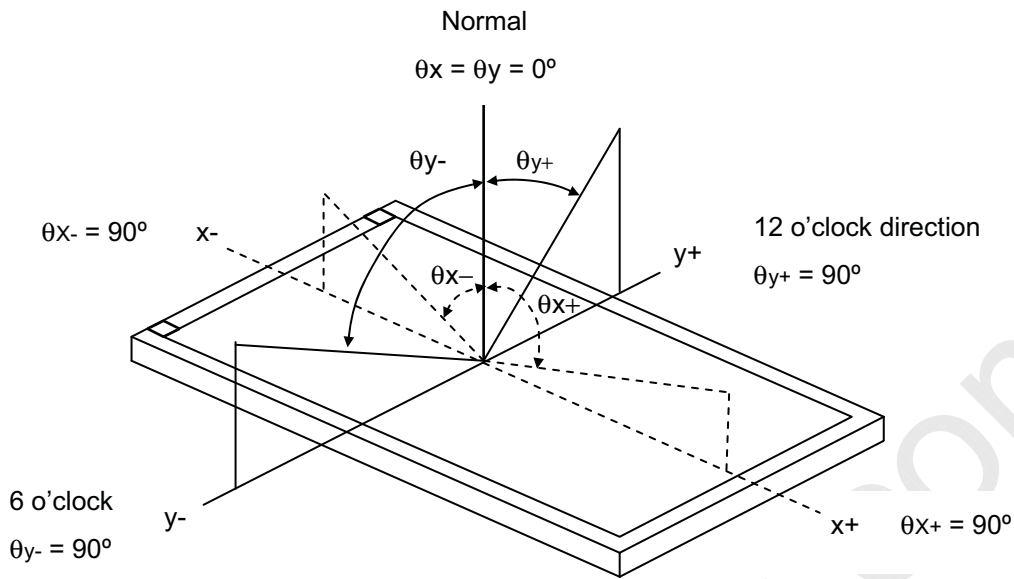

Note (3) Definition of Contrast Ratio (CR):

The contrast ratio can be calculated by the following expression.

$$\text{Contrast Ratio (CR)} = L_{255} / L_0$$

L255: Luminance of gray level 255

L 0: Luminance of gray level 0

$$\text{CR} = \text{CR} (5)$$

CR (X) is corresponding to the Contrast Ratio of the point X at Figure in Note (7).

Note (4) Definition of Response Time (T_R, T_F):

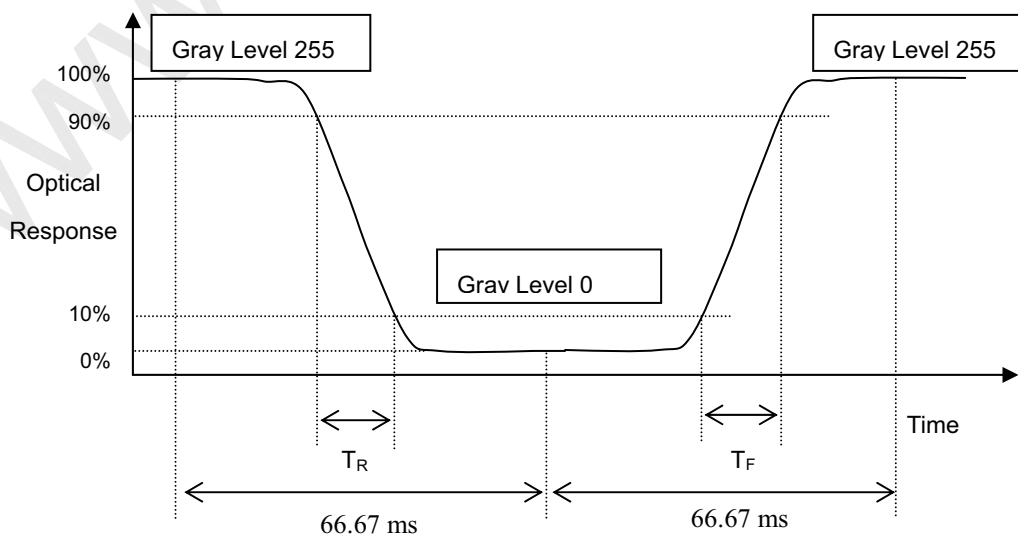

Note (5) Definition of Transmittance (T%):

Module is without signal input.

$L(X)$ and $L_{BLU}(X)$ is corresponding to the luminance of the point X at Figure in Note (7).

Note (6) Measurement Setup:

The LCD module should be stabilized at given temperature for 30minutes to avoid abrupt temperature change during measuring. In order to stabilize the luminance, the measurement should be executed after lighting Backlight for 30minutes in a windless room.

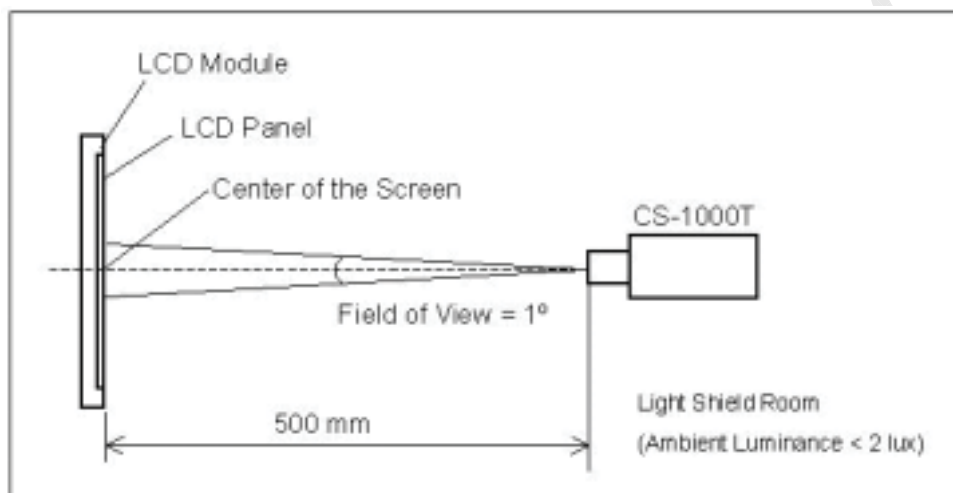

Note (7) Definition of Transmittance Variation ($\delta T\%$):

Measure the transmittance at 9 points

Maximum [$T\%(1), T\%(2), \dots T\%(9)$]

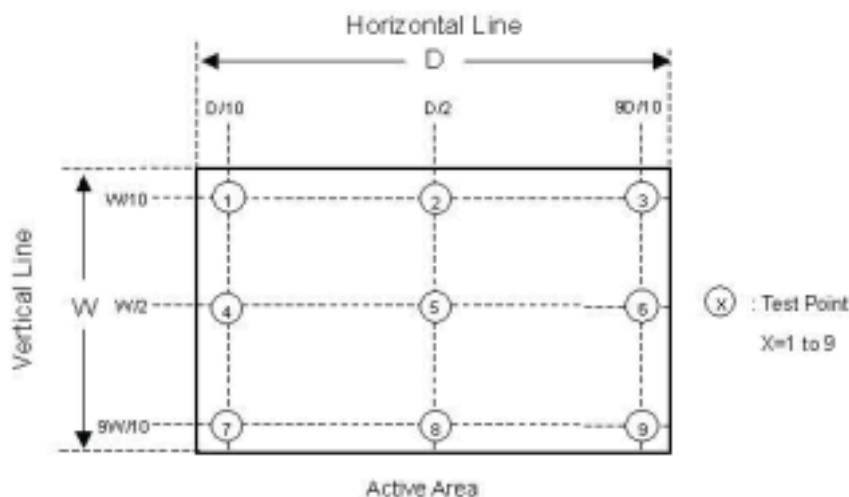

7.3 FLICKER ADJUSTMENT

(1) Adjustment Pattern: 2H1V checker pattern as follows.

R	G	B	R	G	B	R	G	B	R	G	B	R	G	B	R	G	B	R	G	B	R	G	B
R	G	B	R	G	B	R	G	B	R	G	B	R	G	B	R	G	B	R	G	B	R	G	B
R	G	B	R	G	B	R	G	B	R	G	B	R	G	B	R	G	B	R	G	B	R	G	B
R	G	B	R	G	B	R	G	B	R	G	B	R	G	B	R	G	B	R	G	B	R	G	B
R	G	B	R	G	B	R	G	B	R	G	B	R	G	B	R	G	B	R	G	B	R	G	B
R	G	B	R	G	B	R	G	B	R	G	B	R	G	B	R	G	B	R	G	B	R	G	B
R	G	B	R	G	B	R	G	B	R	G	B	R	G	B	R	G	B	R	G	B	R	G	B
R	G	B	R	G	B	R	G	B	R	G	B	R	G	B	R	G	B	R	G	B	R	G	B



(2) Adjustment Method:

Flicker should be adjusted by turning the volume for flicker adjustment by the ceramic driver. It is adjusted to the point with least flickering of the whole screen. After making it surely overrun at once, it should be adjusted to the optimum point.

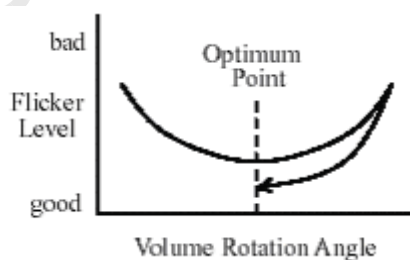



Approval

8. PACKAGING

8.1 PACKING SPECIFICATIONS

- (1) 24 open cells / 1 Box
- (2) Box dimensions: 650 (L) X 495 (W) X 320 (H) mm
- (3) Weight: approximately 21 Kg (24 open cells per box/12 tray)

8.2 PACKING METHOD

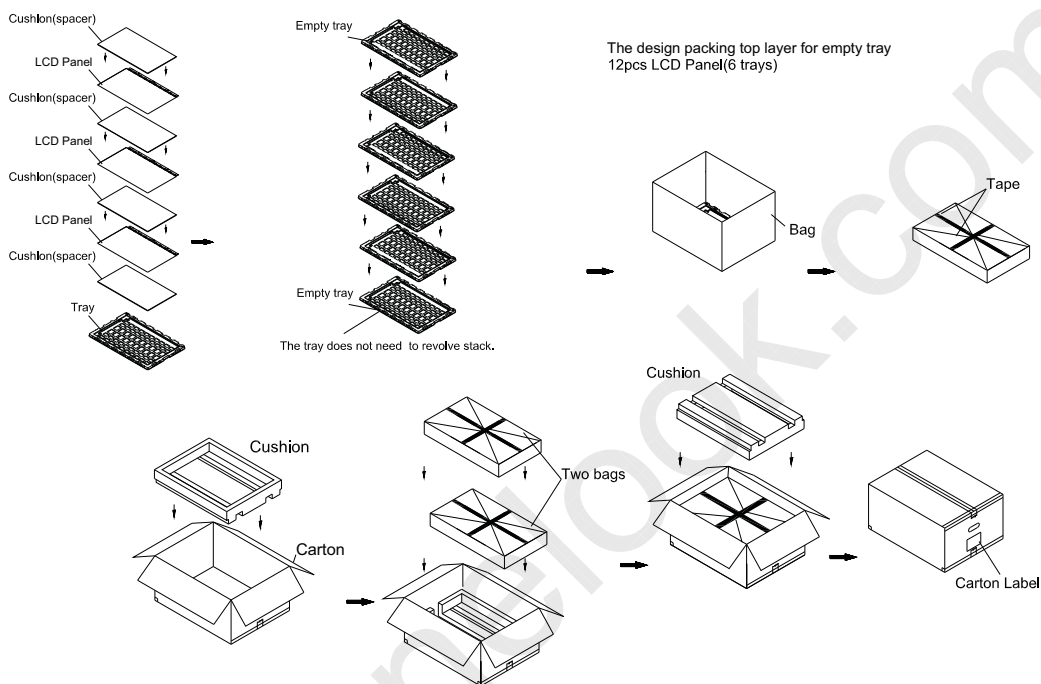

Sea and Land Transportation

Air Transportation

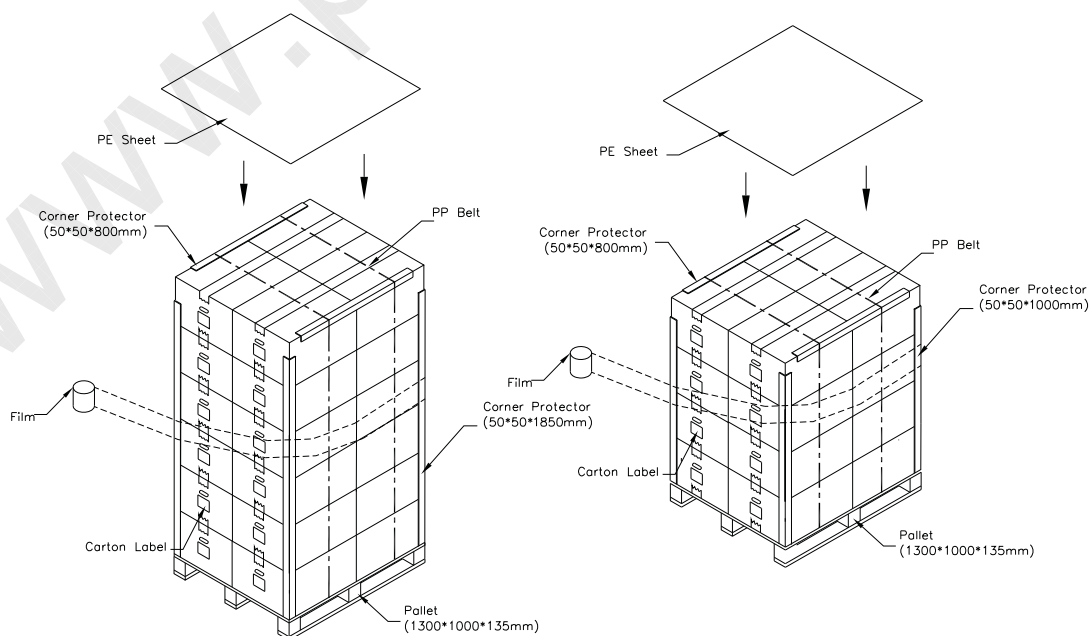



Approval

9. DEFINITION OF LABELS

9.1 CMO OPEN CELL LABEL

The barcode nameplate is pasted on each module as illustration, and its definitions are as following explanation.



Barcode definition:

Serial ID: CM-L5H11-X-X-X-XX-L-XX-L-YMD-NNNN

Code	Meaning	Description
CM	Supplier code	CMO=CM
L5H11	Model number	M215H1-P01=L5H11
X	Revision code	C1:1, C2:2,...
X	Source driver IC code	Century=1, CLL=2, Demos=3, Epson=4, Fujitsu=5, Himax=6, Hitachi=7, Hynix=8, LDI=9, Matsushita=A, NEC=B, Novatec=C, OKI=D, Philips=E, Renasas=F, Samsung=G, Sanyo=H, Sharp=I, TI=J, Topro=K, Toshiba=L, Windbond=M
X	Gate driver IC code	
XX	Cell location	Tainan, Taiwan=TN
L	Cell line #	0~12=1~C
XX	Module location	Tainan, Taiwan=TN
L	Module line #	0~12=1~C
YMD	Year, month, day	Year: 2001=1, 2002=2, 2003=3, 2004=4... Month: 1~12=1, 2, 3, ~, 9, A, B, C Day: 1~31= 1, 2, 3, ~, 9, A, B, C, ~, T, U, V
NNNN	Serial number	Manufacturing sequence of product

9.2 CARTON LABEL

The barcode nameplate is pasted on each box as illustration, and its definitions are as following explanation.



- (1) Model Name: M215H1-P01
- (2) Carton ID: CMO internal control
- (3) Quantities: 24 pcs

**Approval**

10. RELIABILITY TEST

Environment test conditions are listed as following table.

Items	Required Condition	Note
-------	--------------------	------

www.panelook.com

11. PRECAUTIONS

11.1 ASSEMBLY AND HANDLING PRECAUTIONS

- (1) Do not apply rough force such as bending or twisting to the product during assembly.
- (2) To assemble or install module into user's system can be only in clean working areas. The dust and oil may cause electrical short or worsen the polarizer.
- (3) It is not permitted to have pressure or impulse on the product because the LCD panel will be damaged.
- (4) Always follow the correct power sequence when the product is connecting and operating. This can prevent damage to the CMOS LSI chips during latch-up.
- (5) Do not pull the I/F connector in or out while the module is operating.
- (6) Use a soft dry cloth without chemicals for cleaning, because the surface of polarizer is very soft and easily scratched.
- (7) It is dangerous that moisture come into or contacted the product, because moisture may damage the product when it is operating.
- (8) High temperature or humidity may reduce the performance of module. Please store this product within the specified storage conditions.
- (9) When ambient temperature is lower than 10°C may reduce the display quality. For example, the response time will become slowly.

11.2 SAFETY PRECAUTIONS

- (1) If the liquid crystal material leaks from the panel, it should be kept away from the eyes or mouth. In case of contact with hands, skin or clothes, it has to be washed away thoroughly with soap.
- (2) After the product's end of life, it is not harmful in case of normal operation and storage.

11.3 OTHER

- (1) When fixed patterns are displayed for a long time, remnant image is likely to occur.

12. MECHANICAL DRAWING

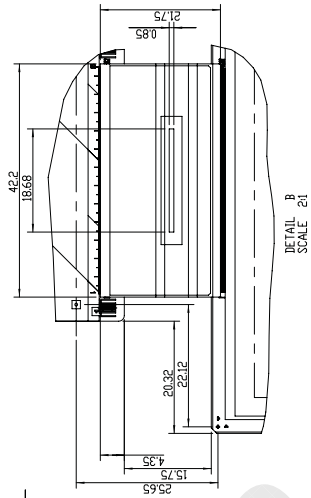
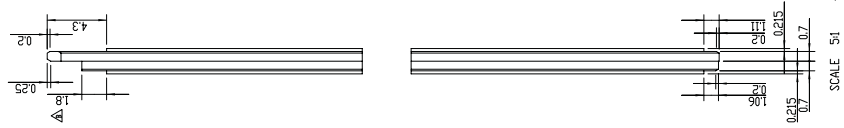
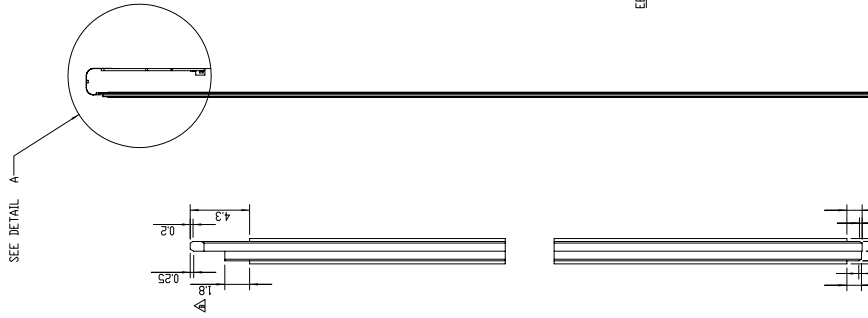
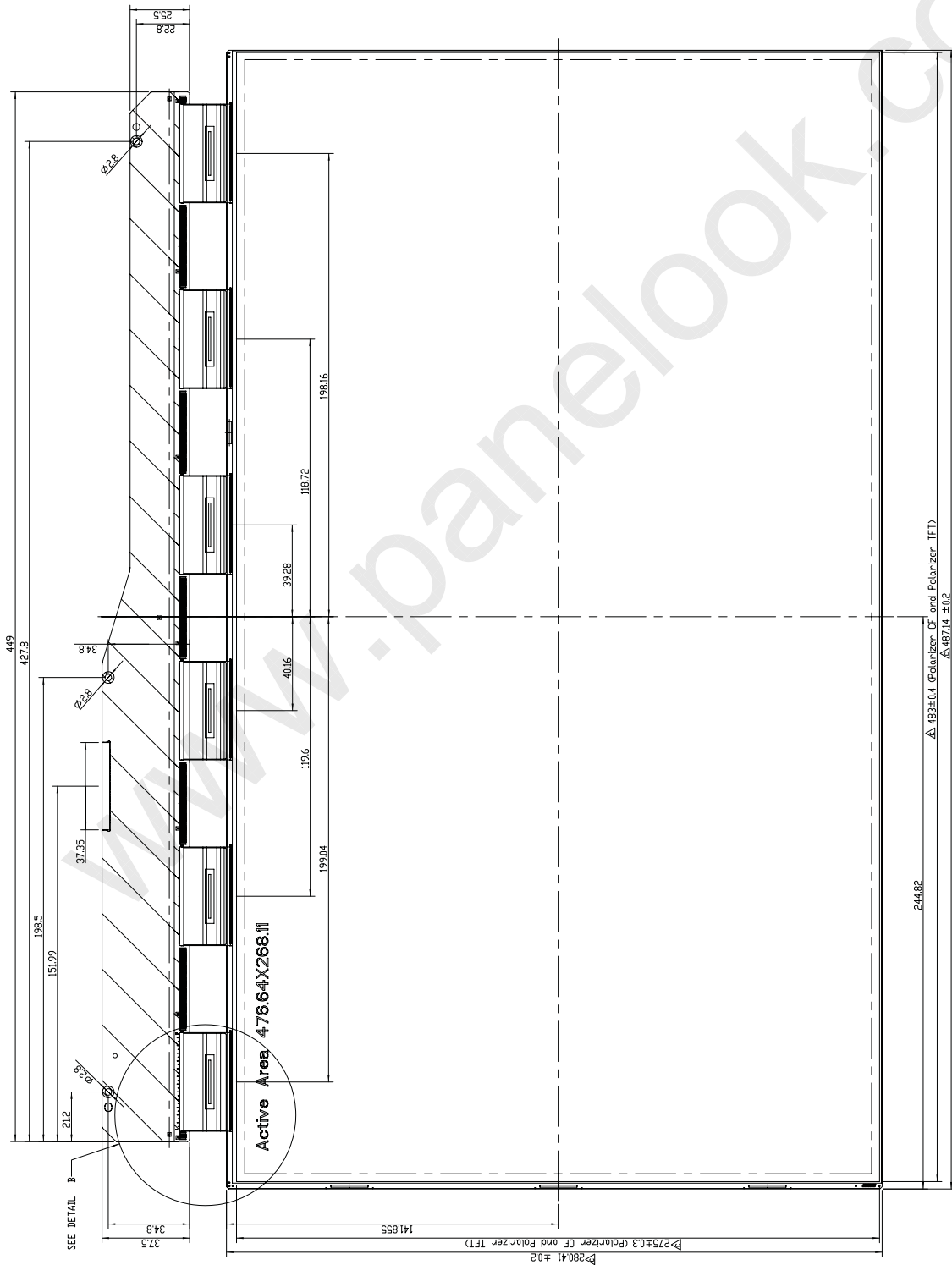

TITLE	ASST_PANEL_M05SH-101
REV. 1	REV. 1
REV. 2	REV. 2
APPROVED	KU, LP
CHECKED	Min_Lee
DRAWN	Honglong Hsu
DESIGNED	Honglong Hsu
DATE	14-Feb-2010
SHEET	1 / 1
DATE	14-Feb-2010
SCALE	1:1
UNIT	mm

ADD TOLERANCE	2010.02.04	Honglong	Min_Lee	EA0053436
MODIFY DIMENSION	2009.09.14	Honglong	Min_Lee	EA0046381
CHANGED BY	CHANGED BY	APPROVED BY	ECN No.	REMARK
1	2	3	4	