

Doc. Number :

- Tentative Specification
- Preliminary Specification
- Approval Specification

MODEL NO.: M215HGE

SUFFIX: P02

Customer: Common Model

APPROVED BY

SIGNATURE

Name / Title _____

Note

Product Version C1

Please return 1 copy for your confirmation with your signature and comments.

Approved By	Checked By	Prepared By
吳柏勳	柯直孝	徐欣怡

- CONTENTS -

1. GENERAL DESCRIPTION	4
1.1 OVERVIEW	4
1.2 GENERAL SPECIFICATIONS	4
2. MECHANICAL SPECIFICATIONS	4
3. ABSOLUTE MAXIMUM RATINGS	4
3.1 ABSOLUTE RATINGS OF ENVIRONMENT	4
3.2 ELECTRICAL ABSOLUTE RATINGS	5
3.2.1 TFT LCD MODULE	5
3.3 ABSOLUTE RATINGS OF ENVIRONMENT (OPEN CELL)	5
4. ELECTRICAL SPECIFICATIONS	6
4.1 FUNCTION BLOCK DIAGRAM	6
4.2. INTERFACE CONNECTIONS	6
4.3 ELECTRICAL CHARACTERISTICS	8
4.4 Vcc POWER DIP CONDITION	10
4.5 LVDS DATA MAPPING TABLE	10
4.6 COLOR DATA INPUT ASSIGNMENT	11
4.7 DISPLAY TIMING SPECIFICATIONS	12
4.8 POWER ON/OFF SEQUENCE	15
5. OPTICAL CHARACTERISTICS	16
5.1 TEST CONDITIONS	16
5.2 OPTICAL SPECIFICATIONS	16
5.3 Flicker Adjustment	19
6. RELIABILITY TEST ITEM	20
7. LABEL	21
7.1 CMI OPEN CELL LABEL	21
8. PACKING	22
8.1 Packing Information	22
8.2 CARTON	22
8.3 PALLET	23
9. PRECAUTIONS	24
9.1 HANDLING PRECAUTIONS	24
9.2 SAFETY PRECAUTIONS	24
9.3 OTHER	24
10. OUTLINE DRAWING	24

REVISION HISTORY

Version	Date	Page	Description
3.0	Aug.30, 2011	All	Spec Ver.3.0 was first issued.

1. GENERAL DESCRIPTION

1.1 OVERVIEW

The M215HGE-P02 is a 21.5" TFT LCD cell with driver ICs and a 30-pins-2ch-LVDS circuit board.

The product supports 1920 x 1080 Full HD mode and can display up to 16.7M colors. The backlight unit is not built in.

1.2 GENERAL SPECIFICATIONS

Item	Specification	Unit	Note
Screen Size	21.5" real diagonal		
Driver Element	a-si TFT active matrix	-	-
Pixel Number	1920 x R.G.B. x 1080	pixel	-
Pixel Pitch	0.2482 (H) x 0.2482 (V)	mm	-
Pixel Arrangement	RGB vertical stripe	-	-
Display Colors	16.7M	color	-
Transmissive Mode	Normally white	-	-
Surface Treatment	AG type, 3H hard coating, Haze 25	-	-
Power Consumption	7.7W (Max.)	Watt	-

2. MECHANICAL SPECIFICATIONS

Item	Min.	Typ.	Max.	Unit	Note
Weight	-	435	455	g	-
I/F connector mounting position	The mounting inclination of the connector makes the screen center within $\pm 0.5\text{mm}$ as the horizontal.			-	(2)

Note (1) Please refer to the attached drawings for more information of front and back outline dimensions.

(2) Connector mounting position

(3) Please refer to sec.3.1 for more information of power consumption.

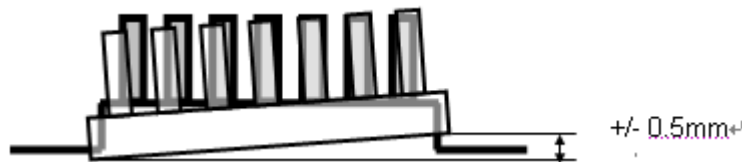

3. ABSOLUTE MAXIMUM RATINGS

3.1 ABSOLUTE RATINGS OF ENVIRONMENT

Item	Symbol	Value		Unit	Note
		Min.	Max.		
Storage Temperature	T_{ST}	-20	+60	$^{\circ}\text{C}$	(1)
Operating Ambient Temperature	T_{OP}	0	+50	$^{\circ}\text{C}$	(1), (2)

Note (1) (a) 90 %RH Max. ($T_a \leq 40^{\circ}\text{C}$).

(b) Wet-bulb temperature should be 39°C Max. ($T_a > 40^{\circ}\text{C}$).

(c) No condensation.

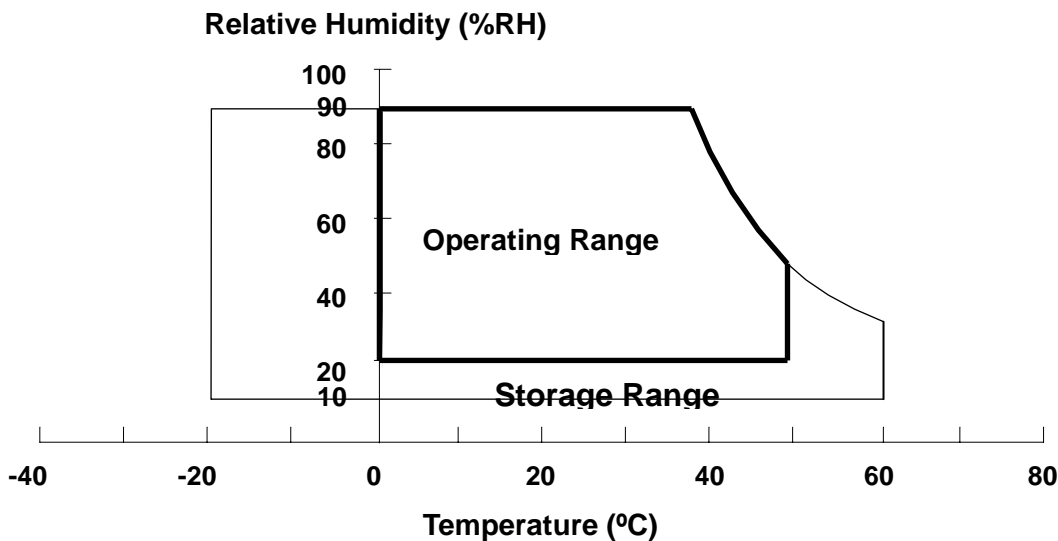

Note (2) The temperature of panel surface should be 0 °C min. and 60 °C max.

3.2 ELECTRICAL ABSOLUTE RATINGS

3.2.1 TFT LCD MODULE

Item	Symbol	Value		Unit	Note
		Min	Max		
Power Supply Voltage	V _{CC}	-0.3	6.0	V	(1)

Note (1) Permanent damage to the device may occur if maximum values are exceeded. Function operation should be restricted to the conditions described under Normal Operating Conditions.

3.3 ABSOLUTE RATINGS OF ENVIRONMENT (OPEN CELL)

High temperature or humidity may reduce the performance of panel. Please store LCD panel within the specified storage conditions.

Storage Condition: With packing.

Storage temperature range: 25±5 °C.

Storage humidity range: 50±10%RH.

Shelf life: 30days

4. ELECTRICAL SPECIFICATIONS

4.1 FUNCTION BLOCK DIAGRAM

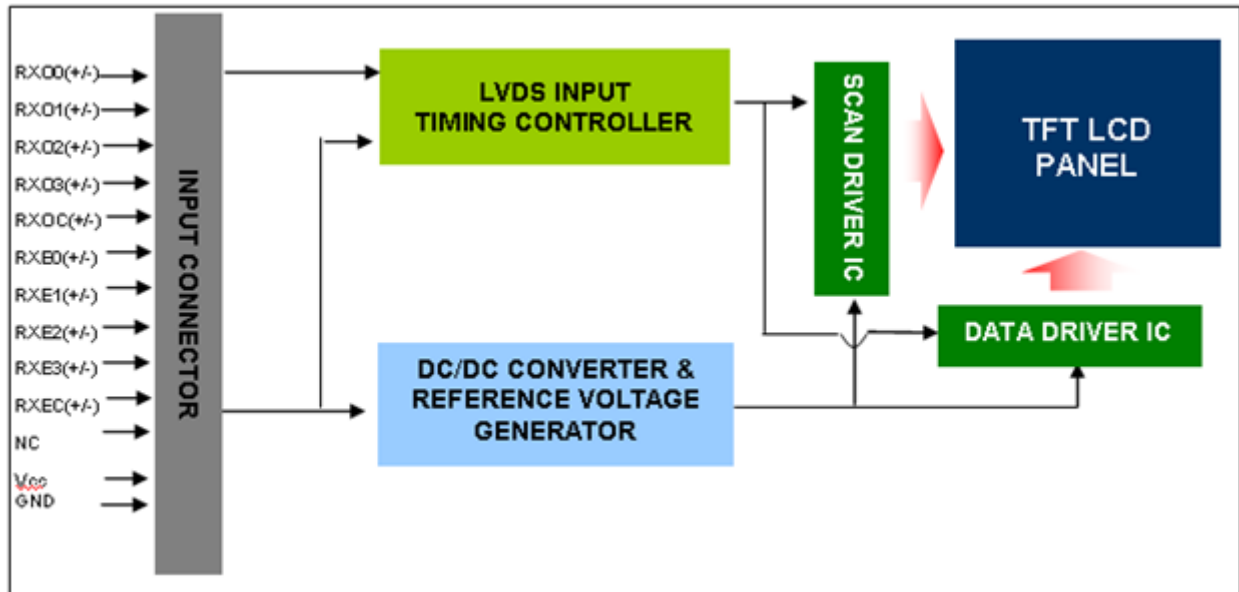

4.2. INTERFACE CONNECTIONS

PIN ASSIGNMENT

Pin	Name	Description
1	RX00-	Negative LVDS differential data input. Channel O0 (odd)
2	RX00+	Positive LVDS differential data input. Channel O0 (odd)
3	RX01-	Negative LVDS differential data input. Channel O1 (odd)
4	RX01+	Positive LVDS differential data input. Channel O1 (odd)
5	RX02-	Negative LVDS differential data input. Channel O2 (odd)
6	RX02+	Positive LVDS differential data input. Channel O2 (odd)
7	GND	Ground
8	RXOC-	Negative LVDS differential clock input. (odd)
9	RXOC+	Positive LVDS differential clock input. (odd)
10	RX03-	Negative LVDS differential data input. Channel O3(odd)
11	RX03+	Positive LVDS differential data input. Channel O3 (odd)
12	RXE0-	Negative LVDS differential data input. Channel E0 (even)
13	RXE0+	Positive LVDS differential data input. Channel E0 (even)
14	GND	Ground
15	RXE1-	Negative LVDS differential data input. Channel E1 (even)
16	RXE1+	Positive LVDS differential data input. Channel E1 (even)
17	GND	Ground
18	RXE2-	Negative LVDS differential data input. Channel E2 (even)
19	RXE2+	Positive LVDS differential data input. Channel E2 (even)
20	RXEC-	Negative LVDS differential clock input. (even)
21	RXEC+	Positive LVDS differential clock input. (even)
22	RXE3-	Negative LVDS differential data input. Channel E3 (even)
23	RXE3+	Positive LVDS differential data input. Channel E3 (even)
24	GND	Ground
25	NC	For LCD internal use only, Do not connect
26	NC	For LCD internal use only, Do not connect
27	NC	For LCD internal use only, Do not connect
28	Vcc	+5.0V power supply

29	Vcc	+5.0V power supply
30	Vcc	+5.0V power supply

Note (1) Connector Part No.:

WF13-422-3033(Fullconn) or 187098-30091(Ptwo) or GS23302-0311R-7H(Foxconn) equivalent

Note (2) User's connector Part No:

Mating Wire Cable Connector Part No.: FI-X30H(JAE) or FI-X30HL(JAE)

Mating FFC Cable Connector Part No.: 217007-013001 (P-TWO) or JF05X030-1 (JAE).

Note (3) The first pixel is odd.

Note (4) Input signal of even and odd clock should be the same timing.

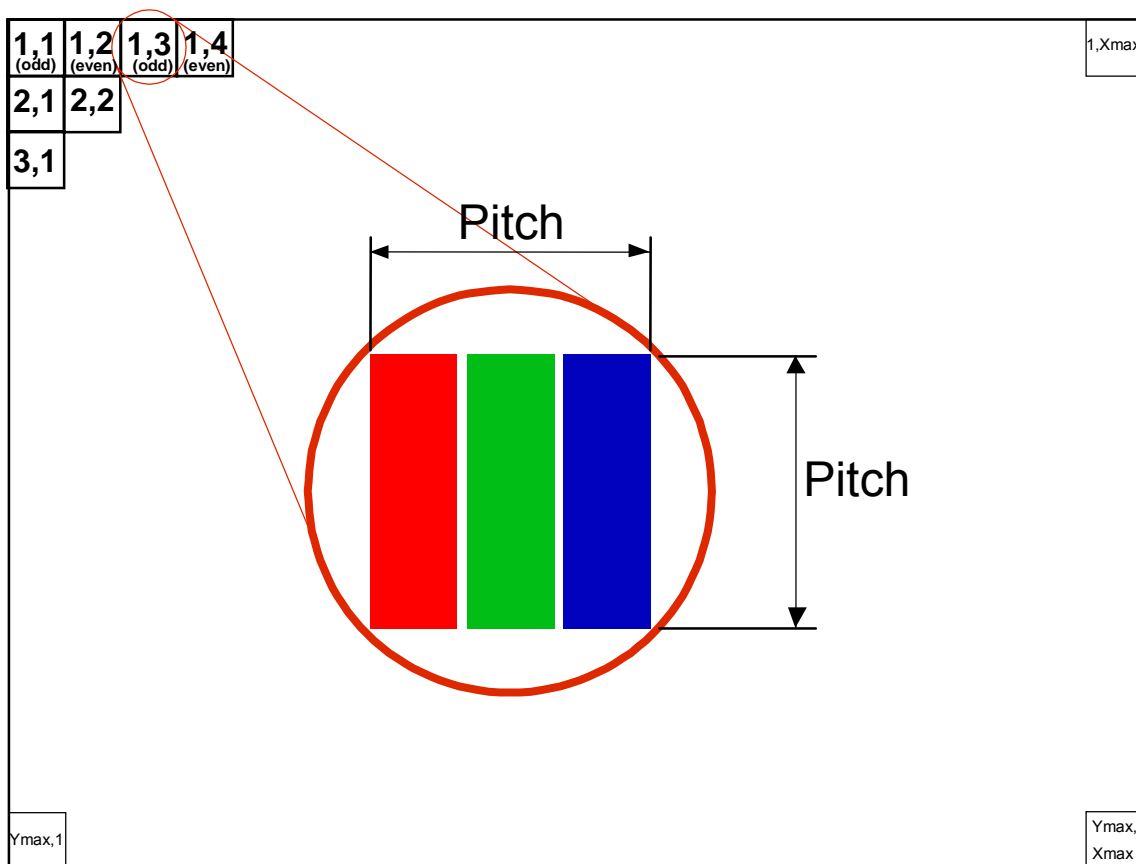

4.3 ELECTRICAL CHARACTERISTICS

Parameter	Symbol	Value			Unit	Note
		Min.	Typ.	Max.		
Power Supply Voltage	Vcc	4.5	5.0	5.5	V	-
Ripple Voltage	V _{RP}	--	--	300	mV	-
Rush Current	I _{RUSH}	--	--	3	A	(2)
Power Supply Current	White	--	0.42	0.47	A	(3)a
	Black	--	1.2	1.4	A	(3)b
	Vertical Stripe	--	0.69	0.71	A	(3)c
Power Consumption	PLCD	-	6.0	7.7	Watt	(4)
LVDS differential input voltage	V _{id}	100	-	600	mV	
LVDS common input voltage	V _{ic}	0.05	--	2.35	V	

Note (1) The ambient temperature is Ta = 25 ± 2 °C.

Note (2) Measurement Conditions:

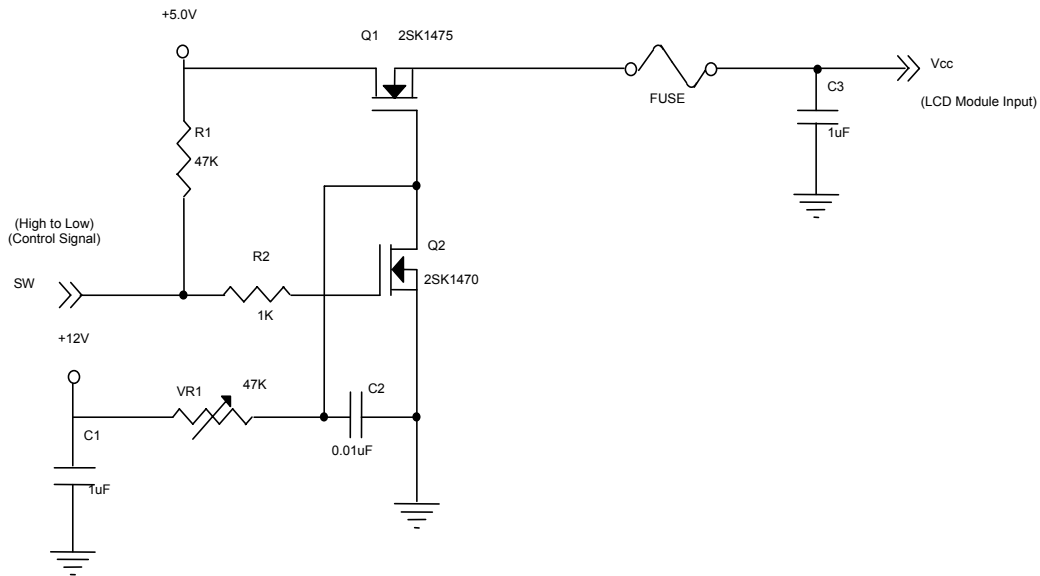

Vcc rising time is 470µs

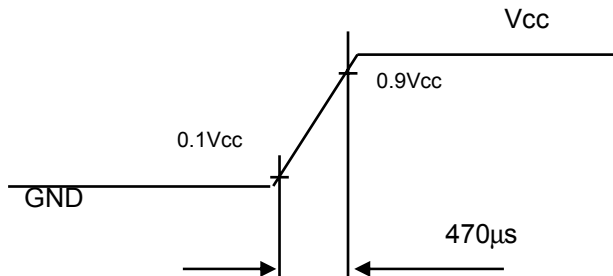

Note (3) The specified power supply current is under the conditions at $V_{CC} = 5.0\text{ V}$, $T_a = 25 \pm 2\text{ }^\circ\text{C}$, $F_v = 60\text{ Hz}$, whereas a power dissipation check pattern below is displayed.

a. White Pattern



Active Area

b. Black Pattern

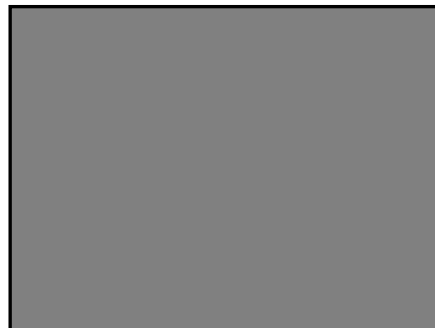

c. Vertical Stripe Pattern

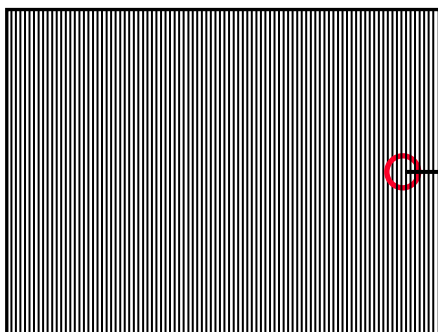

Active Area

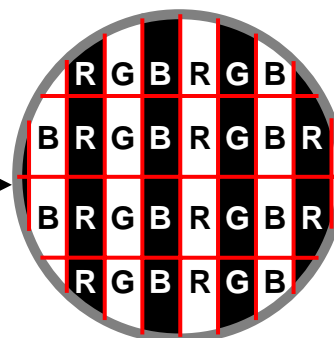

Note (4) The power consumption is specified at the pattern with the maximum current.

Note (5) VID waveform condition

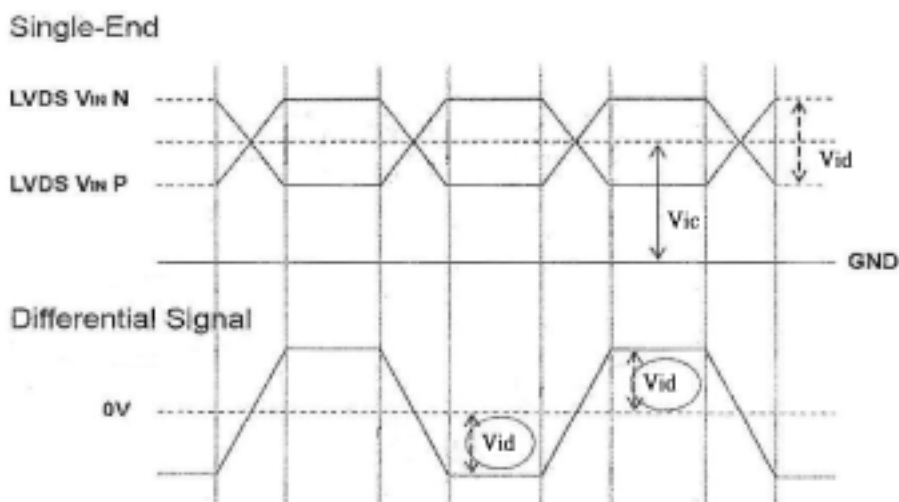

4.4 Vcc POWER DIP CONDITION

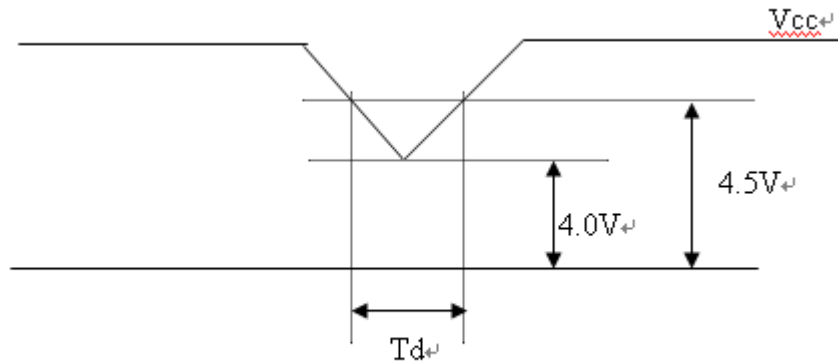

Dip condition: $4.0V \leq V_{cc} \leq 4.5V, T_d \leq 20ms$

4.5 LVDS DATA MAPPING TABLE

LVDS Channel O0	LVDS output	D7	D6	D4	D3	D2	D1	D0
	Data order	OG0	OR5	OR4	OR3	OR2	OR1	OR0
LVDS Channel O1	LVDS output	D18	D15	D14	D13	D12	D9	D8
	Data order	OB1	OB0	OG5	OG4	OG3	OG2	OG1
LVDS Channel O2	LVDS output	D26	D25	D24	D22	D21	D20	D19
	Data order	DE	NA	NA	OB5	OB4	OB3	OB2
LVDS Channel O3	LVDS output	D23	D17	D16	D11	D10	D5	D27
	Data order	NA	OB7	OB6	OG7	OG6	OR7	OR6
LVDS Channel E0	LVDS output	D7	D6	D4	D3	D2	D1	D0
	Data order	EG0	ER5	ER4	ER3	ER2	ER1	ER0
LVDS Channel E1	LVDS output	D18	D15	D14	D13	D12	D9	D8
	Data order	EB1	EB0	EG5	EG4	EG3	EG2	EG1
LVDS Channel E2	LVDS output	D26	D25	D24	D22	D21	D20	D19
	Data order	DE	NA	NA	EB5	EB4	EB3	EB2
LVDS Channel E3	LVDS output	D23	D17	D16	D11	D10	D5	D27
	Data order	NA	EB7	EB6	EG7	EG6	ER7	ER6

4.6 COLOR DATA INPUT ASSIGNMENT

The brightness of each primary color (red, green and blue) is based on the 8-bit gray scale data input for the color. The higher the binary input, the brighter the color. The table below provides the assignment of color versus data input.

Color		Data Signal																							
		Red								Green								Blue							
		R7	R6	R5	R4	R3	R2	R1	R0	R7	R6	G5	G4	G3	G2	G1	G0	R7	R6	B5	B4	B3	B2	B1	B0
Basic Colors	Black	0	0	0	0	0	0	0	0	0	0	0	0	0	0	0	0	0	0	0	0	0	0	0	0
	Red	1	1	1	1	1	1	1	1	0	0	0	0	0	0	0	0	0	0	0	0	0	0	0	0
	Green	0	0	0	0	0	0	0	0	1	1	1	1	1	1	1	1	0	0	0	0	0	0	0	0
	Blue	0	0	0	0	0	0	0	0	0	0	0	0	0	0	0	0	1	1	1	1	1	1	1	1
	Cyan	0	0	0	0	0	0	0	0	1	1	1	1	1	1	1	1	1	1	1	1	1	1	1	1
	Magenta	1	1	1	1	1	1	1	1	0	0	0	0	0	0	0	0	1	1	1	1	1	1	1	1
	Yellow	1	1	1	1	1	1	1	1	1	1	1	1	1	1	1	1	0	0	0	0	0	0	0	0
	White	1	1	1	1	1	1	1	1	1	1	1	1	1	1	1	1	1	1	1	1	1	1	1	1
Gray Scale Of Red	Red(0) / Dark	0	0	0	0	0	0	0	0	0	0	0	0	0	0	0	0	0	0	0	0	0	0	0	0
	Red(1)	0	0	0	0	0	0	0	1	0	0	0	0	0	0	0	0	0	0	0	0	0	0	0	0
	Red(2)	0	0	0	0	0	0	1	0	0	0	0	0	0	0	0	0	0	0	0	0	0	0	0	0
	⋮	⋮	⋮	⋮	⋮	⋮	⋮	⋮	⋮	⋮	⋮	⋮	⋮	⋮	⋮	⋮	⋮	⋮	⋮	⋮	⋮	⋮	⋮	⋮	⋮
	⋮	⋮	⋮	⋮	⋮	⋮	⋮	⋮	⋮	⋮	⋮	⋮	⋮	⋮	⋮	⋮	⋮	⋮	⋮	⋮	⋮	⋮	⋮	⋮	⋮
	Red(253)	1	1	1	1	1	1	0	1	0	0	0	0	0	0	0	0	0	0	0	0	0	0	0	0
	Red(254)	1	1	1	1	1	1	1	0	0	0	0	0	0	0	0	0	0	0	0	0	0	0	0	0
	Red(255)	1	1	1	1	1	1	1	1	0	0	0	0	0	0	0	0	0	0	0	0	0	0	0	0
Gray Scale Of Green	Green(0) / Dark	0	0	0	0	0	0	0	0	0	0	0	0	0	0	0	0	0	0	0	0	0	0	0	0
	Green(1)	0	0	0	0	0	0	0	0	0	0	0	0	0	0	1	0	0	0	0	0	0	0	0	0
	Green(2)	0	0	0	0	0	0	0	0	0	0	0	0	0	1	0	0	0	0	0	0	0	0	0	0
	⋮	⋮	⋮	⋮	⋮	⋮	⋮	⋮	⋮	⋮	⋮	⋮	⋮	⋮	⋮	⋮	⋮	⋮	⋮	⋮	⋮	⋮	⋮	⋮	⋮
	⋮	⋮	⋮	⋮	⋮	⋮	⋮	⋮	⋮	⋮	⋮	⋮	⋮	⋮	⋮	⋮	⋮	⋮	⋮	⋮	⋮	⋮	⋮	⋮	⋮
	Green(253)	0	0	0	0	0	0	0	1	1	1	1	1	1	1	0	1	0	0	0	0	0	0	0	0
	Green(254)	0	0	0	0	0	0	0	1	1	1	1	1	1	1	0	0	0	0	0	0	0	0	0	0
	Green(255)	0	0	0	0	0	0	0	1	1	1	1	1	1	1	1	0	0	0	0	0	0	0	0	0
Gray Scale Of Blue	Blue(0) / Dark	0	0	0	0	0	0	0	0	0	0	0	0	0	0	0	0	0	0	0	0	0	0	0	0
	Blue(1)	0	0	0	0	0	0	0	0	0	0	0	0	0	0	0	0	0	0	0	0	0	0	0	1
	Blue(2)	0	0	0	0	0	0	0	0	0	0	0	0	0	0	0	0	0	0	0	0	0	0	1	0
	⋮	⋮	⋮	⋮	⋮	⋮	⋮	⋮	⋮	⋮	⋮	⋮	⋮	⋮	⋮	⋮	⋮	⋮	⋮	⋮	⋮	⋮	⋮	⋮	⋮
	⋮	⋮	⋮	⋮	⋮	⋮	⋮	⋮	⋮	⋮	⋮	⋮	⋮	⋮	⋮	⋮	⋮	⋮	⋮	⋮	⋮	⋮	⋮	⋮	⋮
	Blue(253)	0	0	0	0	0	0	0	0	0	0	0	0	0	0	0	1	1	1	1	1	1	1	0	1
	Blue(254)	0	0	0	0	0	0	0	0	0	0	0	0	0	0	0	1	1	1	1	1	1	1	1	0
	Blue(255)	0	0	0	0	0	0	0	0	0	0	0	0	0	0	0	1	1	1	1	1	1	1	1	1

Note (1) 0: Low Level Voltage, 1: High Level Voltage

4.7 DISPLAY TIMING SPECIFICATIONS

The input signal timing specifications are shown as the following table and timing diagram.

Signal	Item	Symbol	Min.	Typ.	Max.	Unit	Note
LVDS Clock	Frequency	F _c	58.54	74.25	97.98	MHz	-
	Period	T _c	-	13.47	-	ns	
	Input cycle to cycle jitter	T _{rcj}	--	-	200	ns	(1)
	Input Clock to data skew	TLVCCS			350	ps	(2)
	Spread spectrum modulation range	F _{clkin_mod}	F _c *98%		F _c *102%	MHz	(3)
	Spread spectrum modulation frequency	F _{SSM}			200	KHz	
Vertical Display Term	Frame Rate	Fr	50	60	75	Hz	--
	Total	T _v	1115	1125	1136	Th	T _v =T _{vd} +T _{vb}
	Active Display	T _{vd}	1080	1080	1080	Th	-
	Blank	T _{vb}	T _v -T _{vd}	45	T _v -T _{vd}	Th	-
Horizontal Display Term	Total	T _h	1050	1100	1150	T _c	T _h =T _{hd} +T _{hb}
	Active Display	T _{hd}	960	960	960	T _c	-
	Blank	T _{hb}	T _h -T _{hd}	140	T _h -T _{hd}	T _c	-

Note:(0) Because this module is operated by DE only mode, Hsync and Vsync input signals are ignored.

INPUT SIGNAL TIMING DIAGRAM

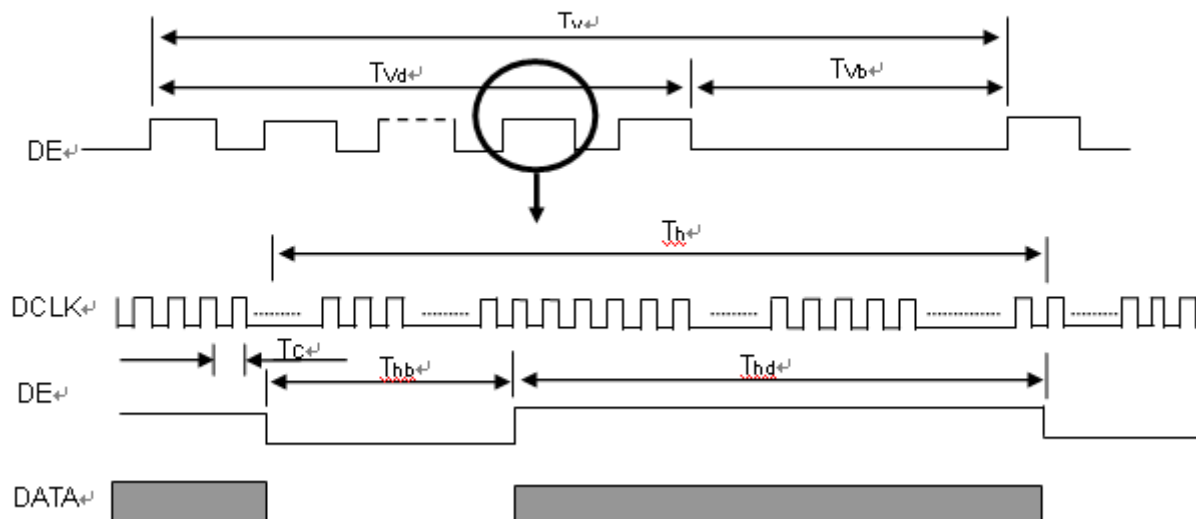

Note (1) The input clock cycle-to-cycle jitter is defined as below figures. $Trcl = |T1 - Tl|$

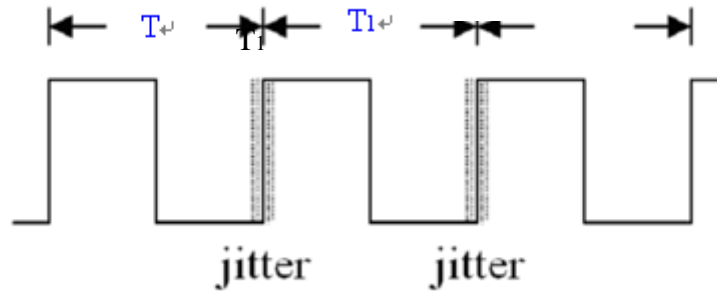

Note (2) The SSCG (Spread spectrum clock generator) is defined as below figures.

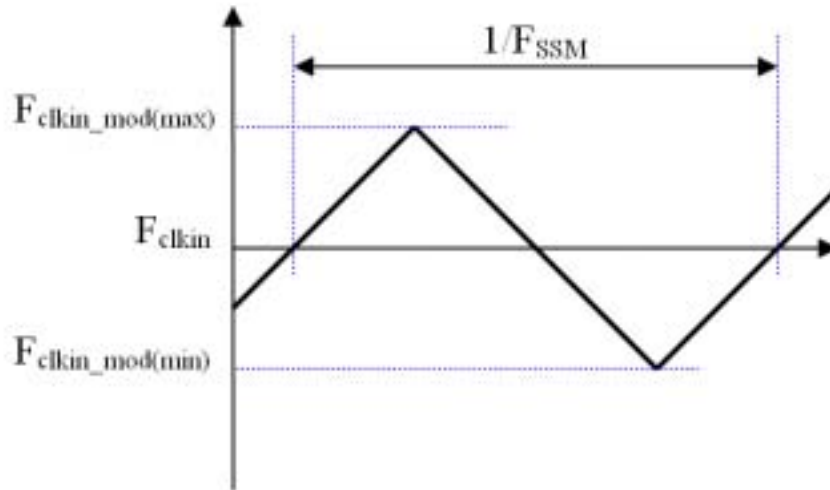

Note (3) Input Clock to data skew is defined as below figures

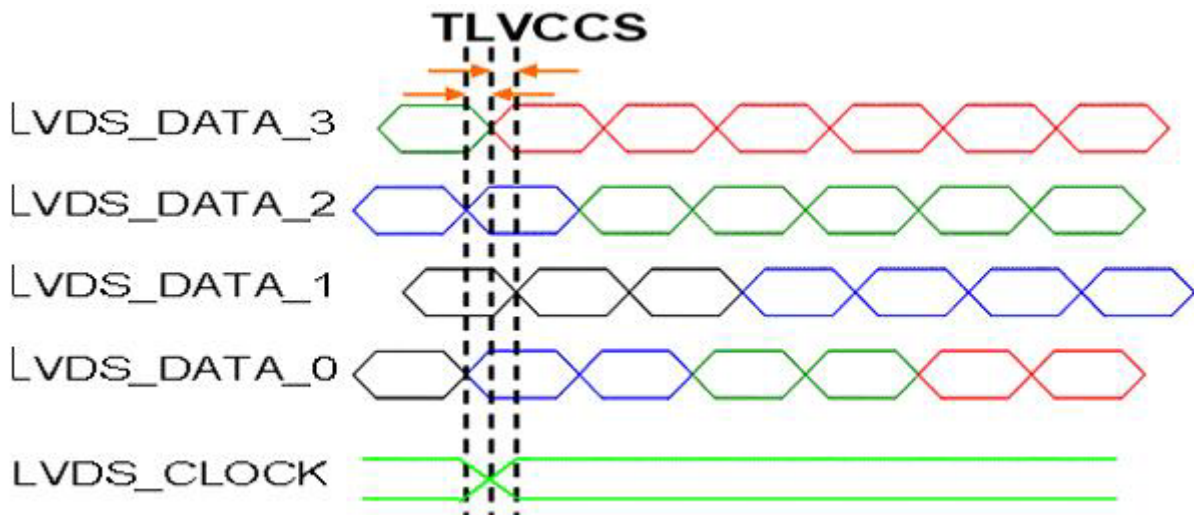

Note (4) The DCLK range at last line of V-blanking should be set in 0 to Hdisplay/2.

4.8 POWER ON/OFF SEQUENCE

To prevent a latch-up or DC operation of LCD module, the power on/off sequence should be as the diagram below.

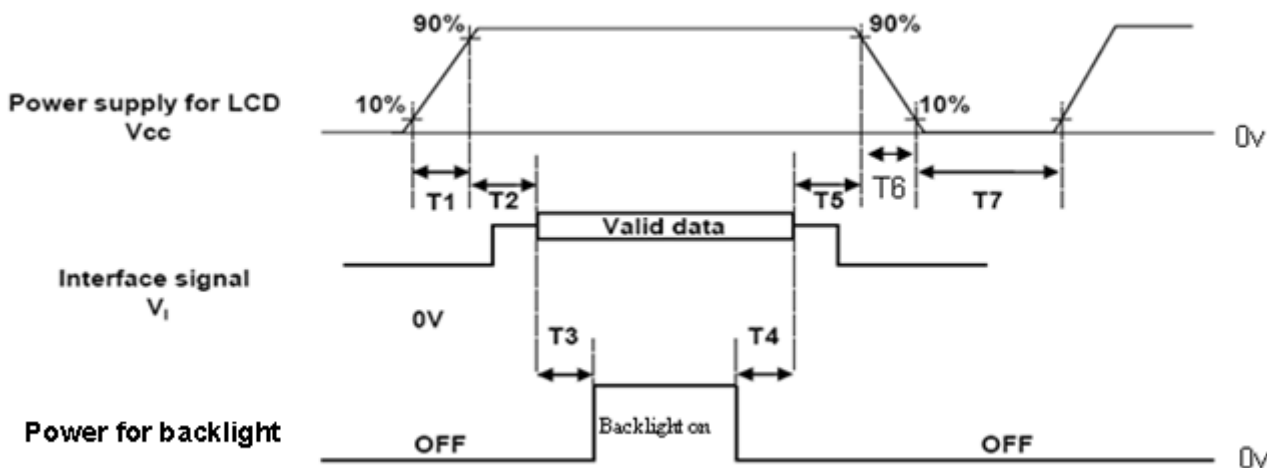

Timing Specifications:

Parameters	Values			Units
	Min	Typ.	Max	
T1	0.5	-	10	ms
T2	0	-	50	ms
T3	450	-	-	ms
T4	90	-	-	ms
T5	0	-	50	ms
T6	5	-	100	ms
T7	500	-	-	ms

Note (1) The supply voltage of the external system for the module input should be the same as the definition of Vcc.

Note (2) When the backlight turns on before the LCD operation of the LCD turns off, the display may momentarily become abnormal screen.

Note (3) In case of VCC = off level, please keep the level of input signals on the low or keep a high impedance.

Note (4) T4 should be measured after the module has been fully discharged between power off and on period.

Note (5) Interface signal shall not be kept at high impedance when the power is on.

Note (6) CMO won't take any responsibility for the products which are damaged by the customers not following the Power Sequence.

Note (7) There might be slight electronic noise when LCD is turned off (even backlight unit is also off). To avoid this symptom, we suggest "Vcc falling timing" to follow "t6 spec".

5. OPTICAL CHARACTERISTICS

5.1 TEST CONDITIONS

Item	Symbol	Value	Unit
Ambient Temperature	Ta	25±2	°C
Ambient Humidity	Ha	50±10	%RH
Supply Voltage	V _{CC}	5	V
Input Signal	According to typical value in "3. ELECTRICAL CHARACTERISTICS"		
LED Light Bar Input Current Per Input Pin	I _{PIN}	65 ± 1.95	mA _{DC}
PWM Duty Ratio	D	100	%
LED Light Bar Test Converter	CMI 35-D064562		

5.2 OPTICAL SPECIFICATIONS

The relative measurement methods of optical characteristics are shown as below. The following items should be measured under the test conditions described in 5.1 and stable environment shown in Note (6).

Item	Symbol	Condition	Min.	Typ.	Max.	Unit	Note	
Color Chromaticity (CIE 1931)	Red	Rx	Typ - 0.03	0.649	Typ + 0.03	-	(2), (6)	
		Ry		0.336				
	Green	Gx		0.290				
		Gy		0.602				
	Blue	Bx		0.138				
		By		0.088				
	White	Wx		0.313				
		Wy		0.329				
	Center Transmittance	T%						(6.3)
Contrast Ratio	CR		700	1000	-	-	(3), (6)	
Response Time	T _R	θ _x =0°, θ _y =0°	-	1.5	2.2	ms	(4)	
	T _F		-	3.5	5.8			
White Variation	δW	θ _x =0°, θ _y =0° USB2000	75	-	-	%	(6), (7)	
Viewing Angle	Horizontal	x- + x+	CR 10 USB2000	150	170	-	Deg.	(2), (6)
	Vertical	y- + y+		140	160			
Viewing Angle	Horizontal	x- + x+	CR 5 USB2000	160	178	---	Deg.	(2), (6)
	Vertical	y- + y+		150	170			

Note (0) Light source is the standard light source "C" which is defined by CIE and driving voltages are based on suitable gamma voltages

Note (1) Light source is the BLU, which is supplied by CMO, and driving voltages are based on suitable gamma voltages. White is without signal input and R, G, B are with signal input. SPEC is judged by CMO's golden sample

Note (2) Definition of Viewing Angle (θ_x, θ_y):

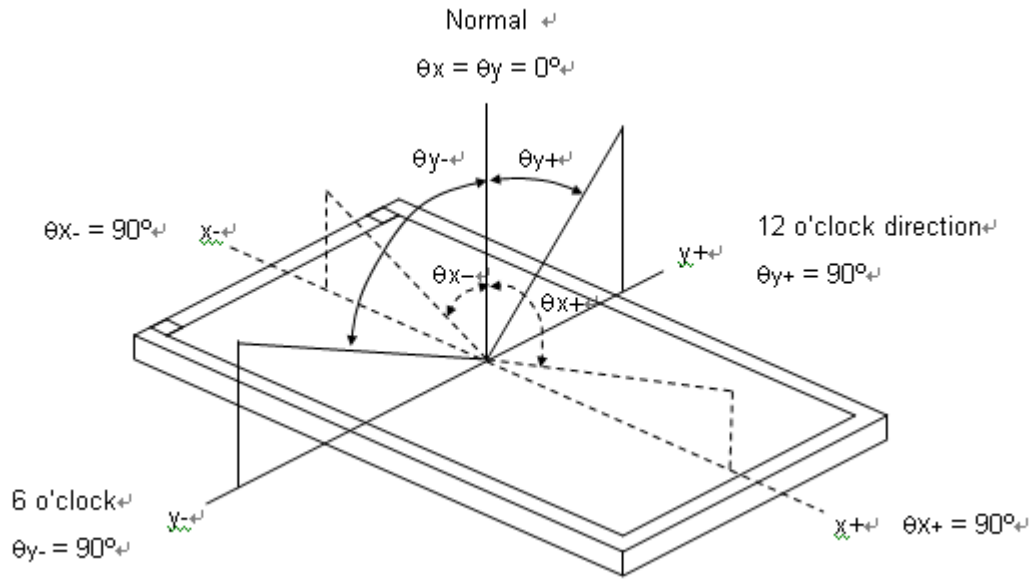

Note (3) : Definition of Contrast Ratio (CR):

The contrast ratio can be calculated by the following expression.

$$\text{Contrast Ratio (CR)} = L_{255} / L_0$$

L255: Luminance of gray level 255

L 0: Luminance of gray level 0

$$\text{CR} = \text{CR} (5)$$

CR (X) is corresponding to the Contrast Ratio of the point X at Figure in Note (8).

Note (4) Definition of Response Time (TR, TF):

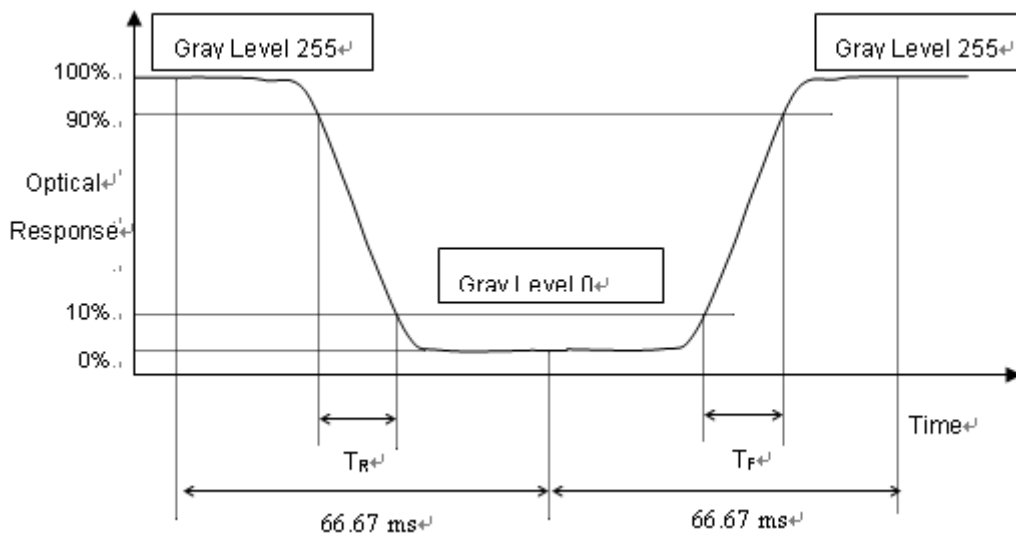

Note (5) Definition of Transmittance (T%):

Module is without signal input.

$$\text{Transmittance} = \frac{\text{Luminance of LCD module } L(5)}{\text{Luminance of backlight } L_{BLU}(5)} * 100\%$$

L (X) and L_{BLU}(X) is corresponding to the luminance of the point X at Figure in Note (8).

Note (6) Measurement Setup:

The LCD module should be stabilized at given temperature for 20minutes to avoid abrupt temperature change during measuring. In order to stabilize the luminance, the measurement should be executed after lighting Backlight for 20minutes in a windless room.

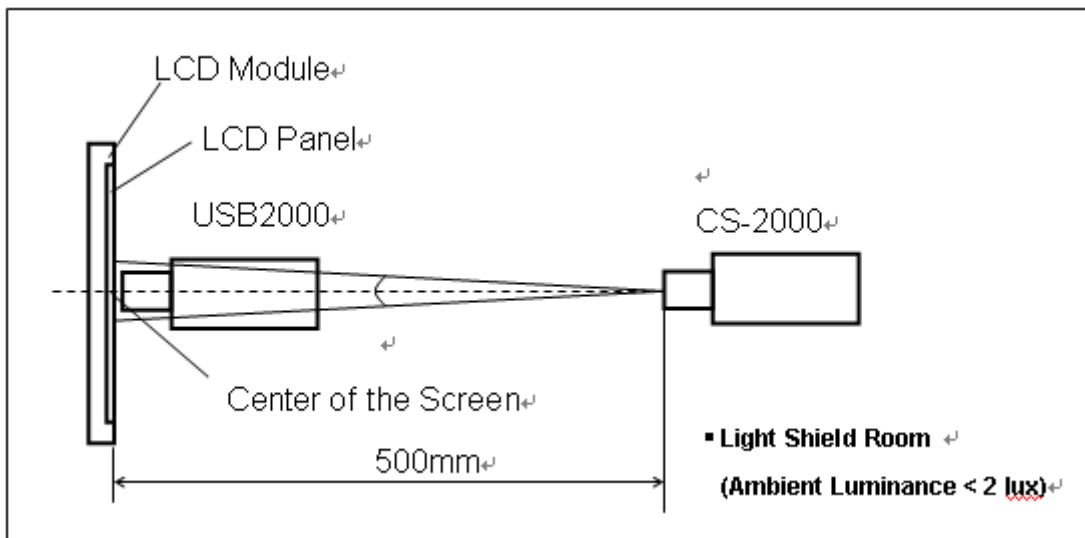

Note (7) : Measurement Setup:

The LCD Panel should be stabilized at given temperature for 30 minutes to avoid abrupt temperature change during measuring. In order to stabilize the luminance, the measurement should be executed after light source "C" for 30 minutes in a windless room.

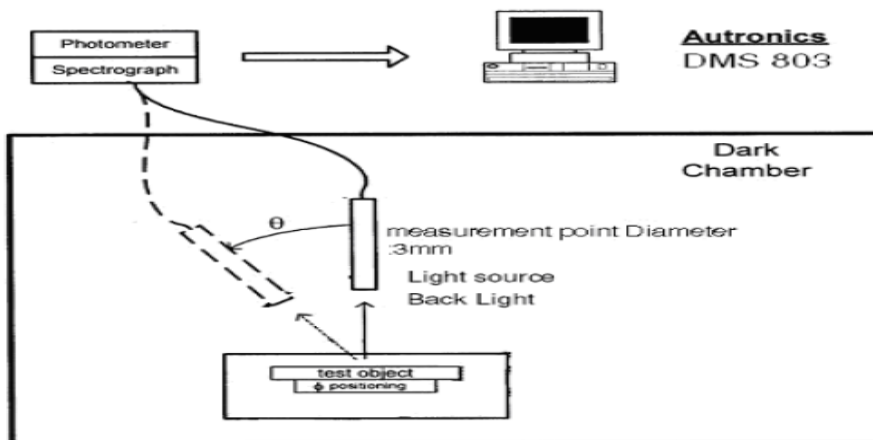

DMS 803

Note (8) : Definition of Transmittance Variation ($\delta T\%$):

Measure the transmittance at 9 points

$$T\% = \frac{\text{Maximum } [T\%(1), T\%(2), \dots T\%(9)]}{\text{Minimum } [T\%(1), T\%(2), \dots T\%(9)]}$$

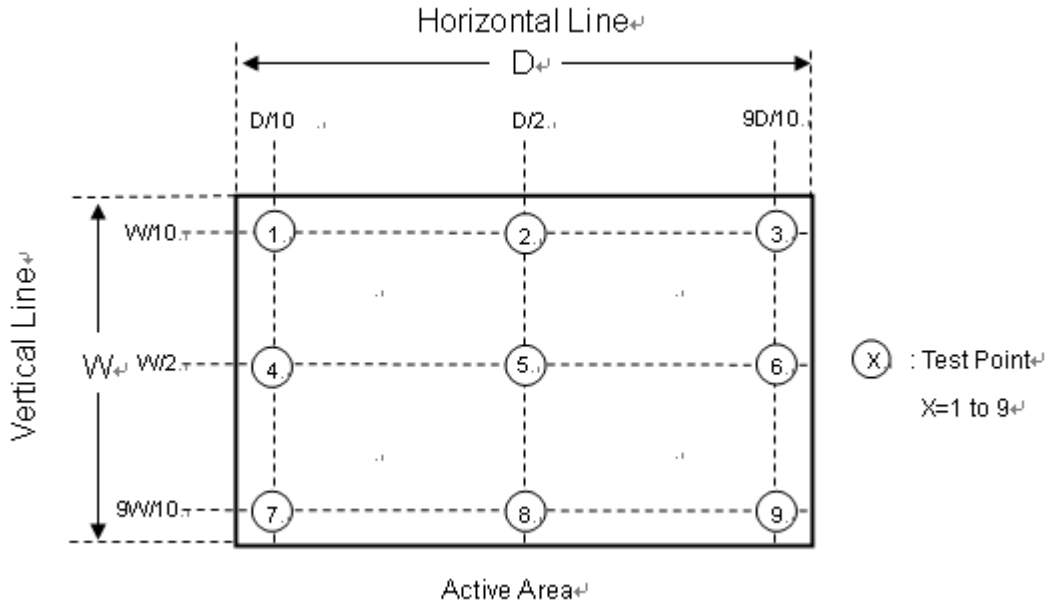

5.3 Flicker Adjustment

Flicker must be finely adjusted after module assembling and aging. Please follow the instructions below.

(1) Adjustment Pattern: 1+2lines checker pattern as follows.

5.3 Flicker Adjustment

Flicker must be finely adjusted after module assembling and aging. Please follow the instructions below.

(1) Adjustment Pattern: 1+2lines checker pattern as follows.

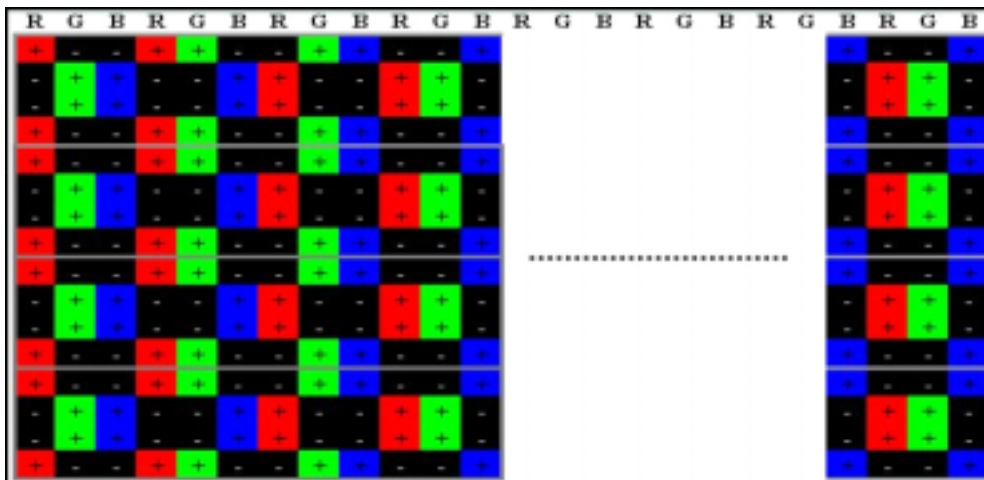

(2) Adjustment Method:

Flicker should be adjusted by turning the volume for flicker adjustment by the ceramic driver. It is adjusted to the point with least flickering of the whole screen. After making it surely overrun at once, it should be adjusted to the optimum point.

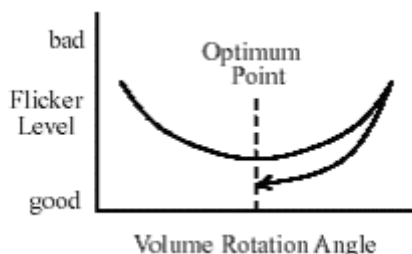

6. RELIABILITY TEST ITEM

Environment test conditions are listed as following table.

Items	Required Condition	Note
Temperature Humidity Bias (THB)	Ta= 50 , 80%RH, 240hours	(1)
High Temperature Operation (HTO)	Ta= 50 , 50%RH , 240hours	
Low Temperature Operation (LTO)	Ta= 0 , 240hours	
High Temperature Storage (HTS)	Ta= 60 , 240hours	
Low Temperature Storage (LTS)	Ta= -20 , 240hours	
Package Vibration Test	ISTA STANDARD 1.14Grms Random, Frequency Range: 1 ~ 200 Hz Top & Bottom: 30 minutes (+Z), 10 min (-Z), Right & Left: 10 minutes (X) Back & Forth 10 minutes (Y)	(2)
Thermal Shock Test (TST)	-20 /30min, 60 / 30min, 100 cycles	(1)
On/Off Test	25 , On/10sec, Off /10sec, 30000 cycles	
Altitude Test	Operation: 10000 ft / 24hours Non-Operation: 30000 ft / 24hours	

Note (1) The tests are done with LCD modules (M215HGE-P02).

Note (2) The test is done with a package shown in Section 8.

7. LABEL

7.1 CMI OPEN CELL LABEL

The barcode nameplate is pasted on each OPEN CELL as illustration for CMI internal control.



Barcode definition:

Serial ID: CM-L5E02-X-X-X-XX-L-XX-L-YMD-NNNN

Code	Meaning	Description
CM	Supplier code	CMI=CM
L5E02	Model number	M215HGE-P02=L5E02
X	Revision code	C1:1, C2:2, ...
X	Source driver IC code	Century=1, CLL=2, Demos=3, Epson=4, Fujitsu=5, Himax=6, Hitachi=7, Hynix=8, LDI=9, Matsushita=A, NEC=B, Novatek=C, OKI=D, Philips=E, Renesas=F, Samsung=G, Sanyo=H, Sharp=I, TI=J, Topro=K, Toshiba=L, Windbond=M
X	Gate driver IC code	
XX	Cell location	Tainan, Taiwan=TN
L	Cell line #	1,2,~,9,A,B,~,Y,Z
XX	Module location	Tainan, Taiwan=TN ; Ningbo China=NP
L	Module line #	1,2,~,9,A,B,~,Y,Z
YMD	Year, month, day	Year: 2001=1, 2002=2, 2003=3, 2004=4... Month: 1~12=1, 2, 3, ~, 9, A, B, C Day: 1~31= 1, 2, 3, ~, 9, A, B, C, ~, T, U, V
NNNN	Serial number	Manufacturing sequence of product

8. PACKING

8.1 Packing Information

- (1) 24 LCD Open CELL / 1 Box
- (2) Box dimensions: 650(L) X 495(W) X 320(H) mm
- (3) Weight: approximately: 19kg (24 open cells per box)

8.2 CARTON

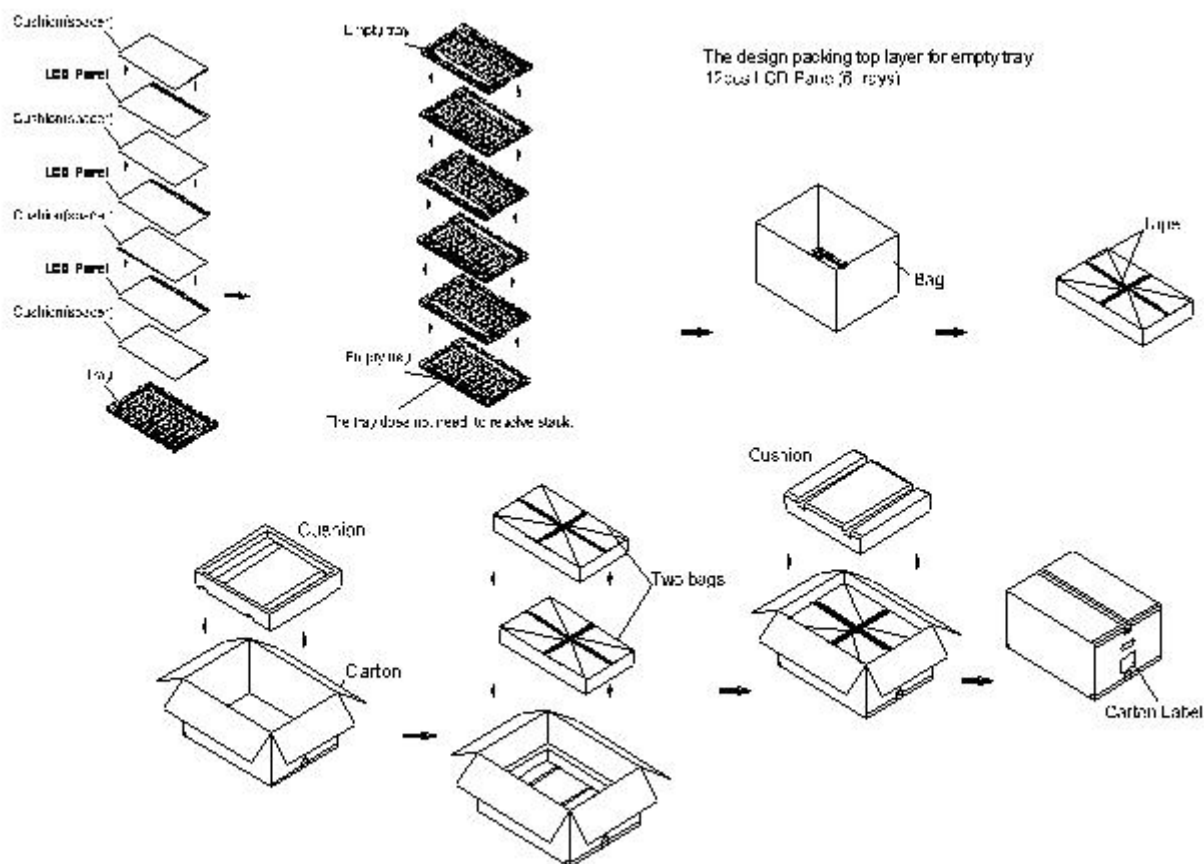

Figure. 8-1 Packing method

8.3 PALLET

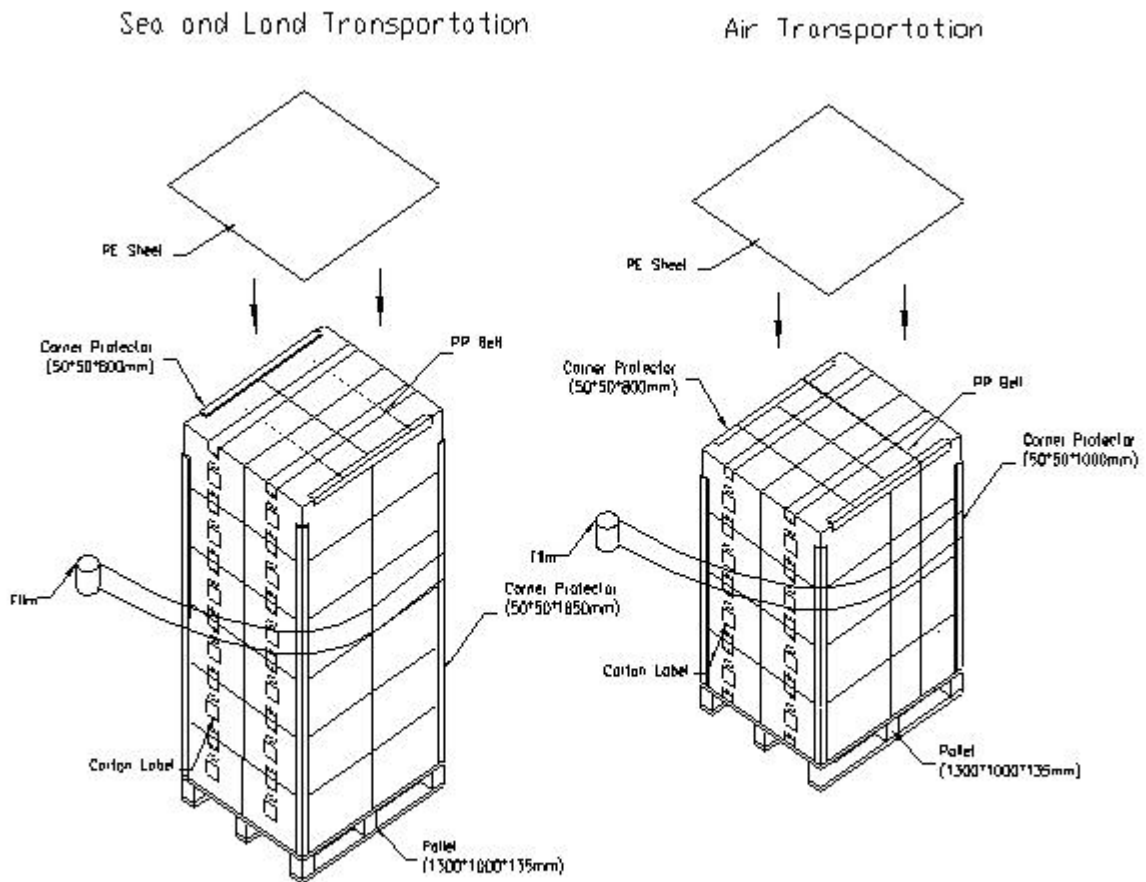

Figure 8-2 Packing method

9. PRECAUTIONS

9.1 HANDLING PRECAUTIONS

- (1) Do not apply rough force such as bending or twisting to the product during assembly.
- (2) To assemble backlight or install module into user's system can be only in clean working areas. The dust and oil may cause electrical short or worsen the polarizer.
- (3) It is not permitted to have pressure or impulse on the module because the LCD panel will be damaged.
- (4) Always follow the correct power sequence when the product is connecting and operating. This can prevent damage to the CMOS LSI chips during latch-up.
- (5) Do not pull the I/F connector in or out while the module is operating.
- (6) Use a soft dry cloth without chemicals for cleaning, because the surface of polarizer is very soft and easily scratched.
- (7) It is dangerous that moisture come into or contacted the product, because moisture may damage the product when it is operating.
- (8) High temperature or humidity may reduce the performance of module. Please store this product within the specified storage conditions.
- (9) When ambient temperature is lower than 10°C may reduce the display quality. For example, the response time will become slowly.

9.2 SAFETY PRECAUTIONS

- (1) If the liquid crystal material leaks from the panel, it should be kept away from the eyes or mouth. In case of contact with hands, skin or clothes, it has to be washed away thoroughly with soap.
- (2) After the product's end of life, it is not harmful in case of normal operation and storage.

9.3 OTHER

- (1) When fixed patterns are displayed for a long time, remnant image is likely to occur.

10. OUTLINE DRAWING