

Doc. Number :

- Tentative Specification
 Preliminary Specification
 Approval Specification

MODEL NO.: M215HGJ
SUFFIX: L21

| | |
|--|------------------|
| Customer: | |
| APPROVED BY | SIGNATURE |
| <u>Name / Title</u> _____ | _____ |
| Note _____ | |
| _____ | |
| Please return 1 copy for your confirmation with your signature and comments. | |

| Approved By | Checked By | Prepared By |
|-------------|------------|-------------|
| 吳柏勳 | 柯直孝 | 趙宗信 |

CONTENTS

| | |
|---|-----------|
| 1. GENERAL DESCRIPTION | 5 |
| 1.1 OVERVIEW | 5 |
| 1.2 GENERAL SPECIFICATIONS | 5 |
| 2. MECHANICAL SPECIFICATIONS | 5 |
| 3. ABSOLUTE MAXIMUM RATINGS | 6 |
| 3.1 ABSOLUTE RATINGS OF ENVIRONMENT | 6 |
| 3.2 ELECTRICAL ABSOLUTE RATINGS | 7 |
| 3.2.1 TFT LCD MODULE | 7 |
| 3.2.2 BACKLIGHT UNIT | 7 |
| 4. ELECTRICAL SPECIFICATIONS | 8 |
| 4.1 FUNCTION BLOCK DIAGRAM | 8 |
| 4.2. INTERFACE CONNECTIONS | 8 |
| 4.3 ELECTRICAL CHARACTERISTICS | 10 |
| 4.3.1 LCD ELETRONICS SPECIFICATION | 10 |
| 4.3.2 Vcc Power Dip Condition | 12 |
| 4.3.3 BACKLIGHT UNIT | 12 |
| 4.3.4 LIGHTBAR Connector Pin Assignment | 13 |
| 4.4 LVDS INPUT SIGNAL SPECIFICATIONS | 14 |
| 4.4.1 LVDS DATA MAPPING TABLE | 14 |
| 4.4.2 COLOR DATA INPUT ASSIGNMENT | 15 |
| 4.5 DISPLAY TIMING SPECIFICATIONS | 16 |
| 4.6 POWER ON/OFF SEQUENCE | 18 |
| 5. OPTICAL CHARACTERISTICS | 19 |
| 5.1 TEST CONDITIONS | 19 |
| 5.2 OPTICAL SPECIFICATIONS | 19 |
| 6. RELIABILITY TEST ITEM | 22 |
| 7. PACKING | 23 |
| 7.1 PACKING SPECIFICATIONS | 23 |
| 7.2 PACKING METHOD | 23 |
| 7.3 PALLET | 24 |
| 8. CMI MODULE LABEL | 25 |
| 9. PRECAUTIONS | 27 |
| 9.1 ASSEMBLY AND HANDLING PRECAUTIONS | 27 |
| 9.2 STORAGE PRECAUTIONS | 27 |
| 9.3 OPERATION PRECAUTIONS | 27 |

| | |
|--|-----------|
| 9.4 SAFETY PRECAUTIONS | 27 |
| 9.5 SAFETY STANDARDS | 28 |
| 9.6 OTHER | 28 |
| Appendix. OUTLINE DRAWING | 28 |

REVISION HISTORY

| Version | Date | Page | Description |
|---------|--------------|------|--------------------------------|
| 2.0 | May.10, 2011 | All | Spec Ver.2.0 was first issued. |
| | | | |
| | | | |
| | | | |
| | | | |
| | | | |
| | | | |
| | | | |
| | | | |
| | | | |
| | | | |
| | | | |
| | | | |
| | | | |
| | | | |

1. GENERAL DESCRIPTION

1.1 OVERVIEW

M215HGJ-L21 is a 21.5" TFT Liquid Crystal Display module with WLED Backlight unit and 30 pins 2ch-LVDS interface. This module supports 1920 x 1080 Full HD mode and can display up to 16.7M colors. The converter module for Backlight is not built in.

1.2 GENERAL SPECIFICATIONS

| Item | Specification | Unit | Note |
|-------------------|---|-------------------|------|
| Screen Size | 21.53" real diagonal | | |
| Driver Element | a-si TFT active matrix | - | - |
| Pixel Number | 1920 x R.G.B. x 1080 | pixel | - |
| Pixel Pitch | 0.2482 (H) x 0.2482 (V) | mm | - |
| Pixel Arrangement | RGB vertical stripe | - | - |
| Display Colors | 16.7M | color | - |
| Transmissive Mode | Normally white | - | - |
| Surface Treatment | AG type, 3H hard coating, Haze 25 | - | - |
| Luminance, White | 250 | Cd/m ² | |
| Power Consumption | Total 13.37 W (Max.) @ cell 6.3W (Max.), BL 7.07 W (Max.) | | (1) |

Note (1) The specified power consumption : Total= cell (reference 4.3.1)+BL (reference 4.3.3)

2. MECHANICAL SPECIFICATIONS

| Item | | Min. | Typ. | Max. | Unit | Note |
|-------------|----------------|--------|--------|--------|------|------|
| Module Size | Horizontal (H) | 495.1 | 495.6 | 496.1 | mm | (1) |
| | Vertical (V) | 291.7 | 292.2 | 292.7 | mm | |
| | Thickness (T) | | 8.9 | 9.4 | mm | |
| Bezel Area | Horizontal | 479.54 | 479.84 | 480.14 | mm | |
| | Vertical | 271.01 | 271.31 | 271.61 | mm | |
| Active Area | Horizontal | | 476.64 | - | mm | |
| | Vertical | | 268.11 | - | mm | |
| Weight | | - | 1742 | 1810 | g | |

Note (1) Please refer to the attached drawings for more information of front and back outline dimensions.

3. ABSOLUTE MAXIMUM RATINGS

3.1 ABSOLUTE RATINGS OF ENVIRONMENT

| Item | Symbol | Value | | Unit | Note |
|-------------------------------|--------|-------|------|------|----------|
| | | Min. | Max. | | |
| Storage Temperature | TST | -20 | 60 | °C | (1) |
| Operating Ambient Temperature | TOP | 0 | 50 | °C | (1), (2) |

Note (1)

(a) 90 %RH Max. ($T_a \leq 40$ °C).

(b) Wet-bulb temperature should be 39 °C Max. ($T_a > 40$ °C).

(c) No condensation.

Note (2) The temperature of panel surface should be 0 °C min. and 60 °C max.

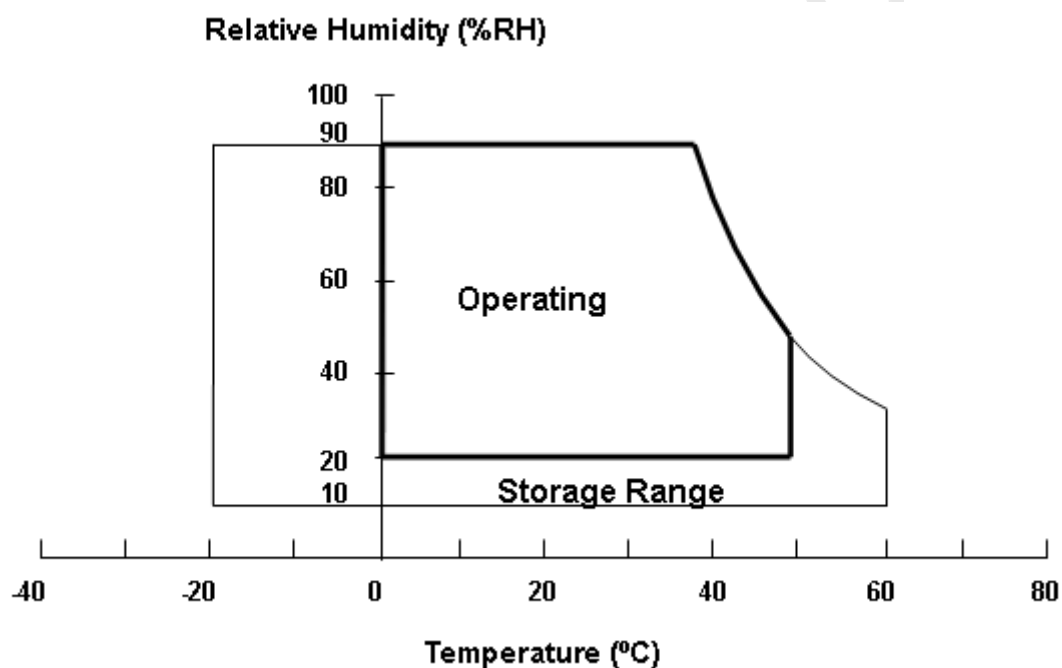

3.2 ELECTRICAL ABSOLUTE RATINGS

3.2.1 TFT LCD MODULE

| Item | Symbol | Value | | Unit | Note |
|----------------------|--------|-------|------|------|------|
| | | Min. | Max. | | |
| Power Supply Voltage | VCC | -0.3 | 6.0 | V | (1) |

3.2.2 BACKLIGHT UNIT

| Item | Symbol | Value | | | Unit | Note |
|---|--------|----------|-----------|------------|------|---|
| | | Min. | Typ | Max. | | |
| LED Forward Current Per Input Pin | I_F | 0 | 65 | 70 | mA | (1), (2) Duty=100% |
| LED Reverse Current Per Input Pin | I_R | --- | --- | 85 | mA | |
| LED Pulse Forward Current Per Input Pin | I_P | --- | --- | 150 | mA | (1), (2) Pulse Width \leq 10msec. and Duty \leq 10% |

Note (1) Permanent damage to the device may occur if maximum values are exceeded. Function operation should be restricted to the conditions described under Normal Operating Conditions.

Note (2) Specified values are for input pin of LED light bar at $T_a=25\pm 2$ °C (Refer to 4.3.3 and 4.3.4 for further information).

4. ELECTRICAL SPECIFICATIONS

4.1 FUNCTION BLOCK DIAGRAM

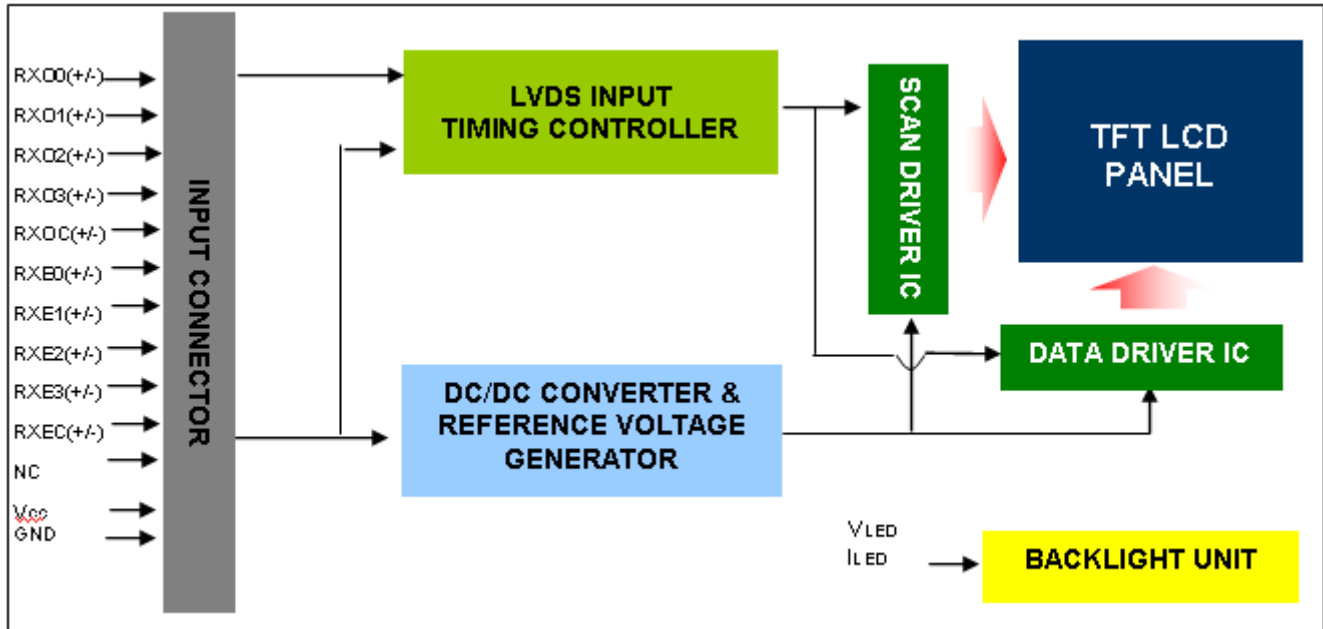

4.2. INTERFACE CONNECTIONS

PIN ASSIGNMENT

| Pin | Name | Description |
|-----|-------|--|
| 1 | RX00- | Negative LVDS differential data input. Channel O0 (odd) |
| 2 | RX00+ | Positive LVDS differential data input. Channel O0 (odd) |
| 3 | RX01- | Negative LVDS differential data input. Channel O1 (odd) |
| 4 | RX01+ | Positive LVDS differential data input. Channel O1 (odd) |
| 5 | RX02- | Negative LVDS differential data input. Channel O2 (odd) |
| 6 | RX02+ | Positive LVDS differential data input. Channel O2 (odd) |
| 7 | GND | Ground |
| 8 | RXOC- | Negative LVDS differential clock input. (odd) |
| 9 | RXOC+ | Positive LVDS differential clock input. (odd) |
| 10 | RX03- | Negative LVDS differential data input. Channel O3(odd) |
| 11 | RX03+ | Positive LVDS differential data input. Channel O3 (odd) |
| 12 | RXE0- | Negative LVDS differential data input. Channel E0 (even) |
| 13 | RXE0+ | Positive LVDS differential data input. Channel E0 (even) |
| 14 | GND | Ground |
| 15 | RXE1- | Negative LVDS differential data input. Channel E1 (even) |
| 16 | RXE1+ | Positive LVDS differential data input. Channel E1 (even) |
| 17 | GND | Ground |
| 18 | RXE2- | Negative LVDS differential data input. Channel E2 (even) |
| 19 | RXE2+ | Positive LVDS differential data input. Channel E2 (even) |
| 20 | RXEC- | Negative LVDS differential clock input. (even) |
| 21 | RXEC+ | Positive LVDS differential clock input. (even) |
| 22 | RXE3- | Negative LVDS differential data input. Channel E3 (even) |
| 23 | RXE3+ | Positive LVDS differential data input. Channel E3 (even) |
| 24 | GND | Ground |
| 25 | NC | For LCD internal use only, Do not connect |

| | | |
|----|-----|---|
| 26 | NC | For LCD internal use only, Do not connect |
| 27 | NC | For LCD internal use only, Do not connect |
| 28 | Vcc | +5.0V power supply |
| 29 | Vcc | +5.0V power supply |
| 30 | Vcc | +5.0V power supply |

Note (1) Connector Part No.:

093G30-B0001A(STARCONN) or MSAKT2407P30HA(STM) or equivalent

Note (2) User's connector Part No:

Mating Wire Cable Connector Part No.: FI-X30H(JAE) or FI-X30HL(JAE)

Mating FFC Cable Connector Part No.: 217007-013001 (P-TWO) or JF05X030-1 (JAE).

Note (3) The first pixel is odd.

Note (4) Input signal of even and odd clock should be the same timing.

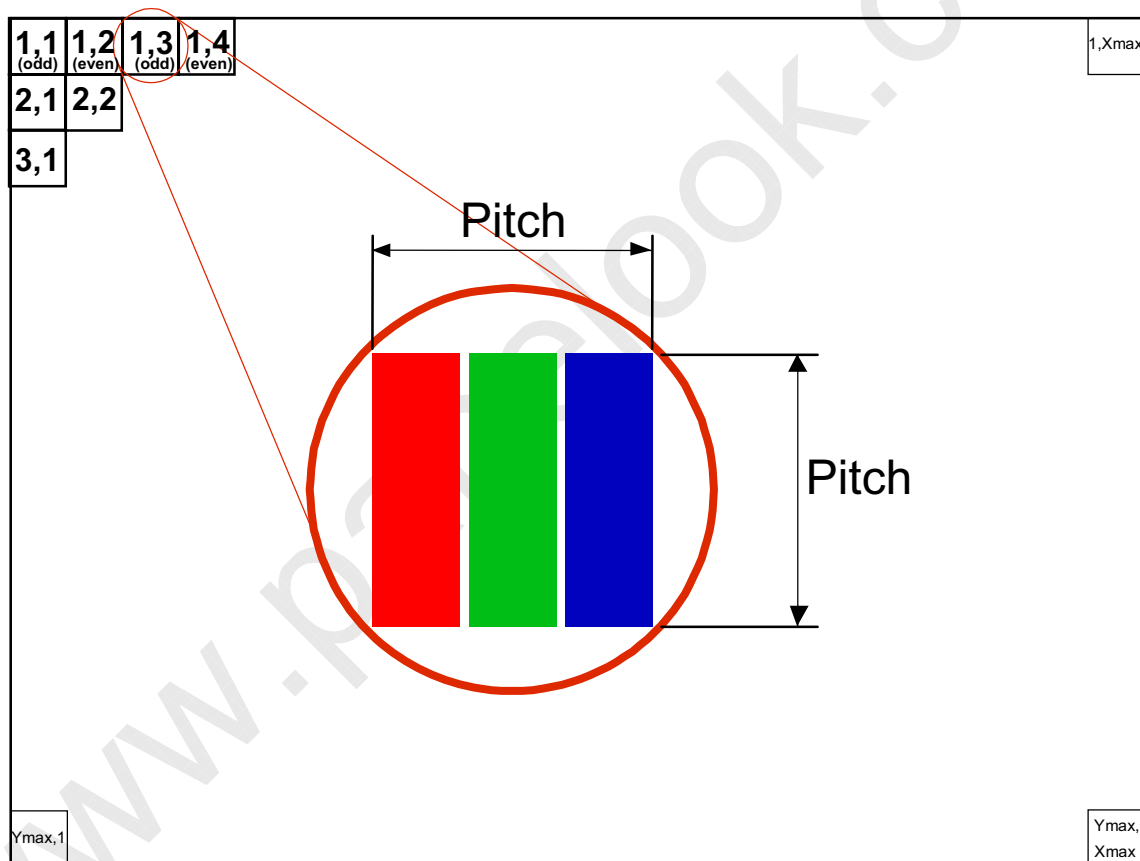

4.3 ELECTRICAL CHARACTERISTICS

4.3.1 LCD ELETRONICS SPECIFICATION

| Parameter | Symbol | Value | | | Unit | Note |
|---------------------------------|-------------------|-------|------|------|------|------|
| | | Min. | Typ. | Max. | | |
| Power Supply Voltage | Vcc | 4.5 | 5.0 | 5.5 | V | - |
| Ripple Voltage | V _{RP} | -- | -- | 300 | mV | - |
| Rush Current | I _{RUSH} | -- | -- | 3 | A | (2) |
| Power Supply Current | White | - | 0.51 | 0.61 | A | (3)a |
| | Black | - | 1.05 | 1.26 | A | (3)b |
| | Vertical Stripe | - | 1.06 | 1.26 | A | (3)c |
| Power Consumption | PLCD | - | 5.3 | 6.3 | Watt | (4) |
| LVDS differential input voltage | V _{id} | 200 | - | 600 | mV | |
| LVDS common input voltage | V _{ic} | 1 | 1.2 | 1.4 | V | |

Note (1) The ambient temperature is $T_a = 25 \pm 2 \text{ }^\circ\text{C}$.

Note (2) Measurement Conditions:

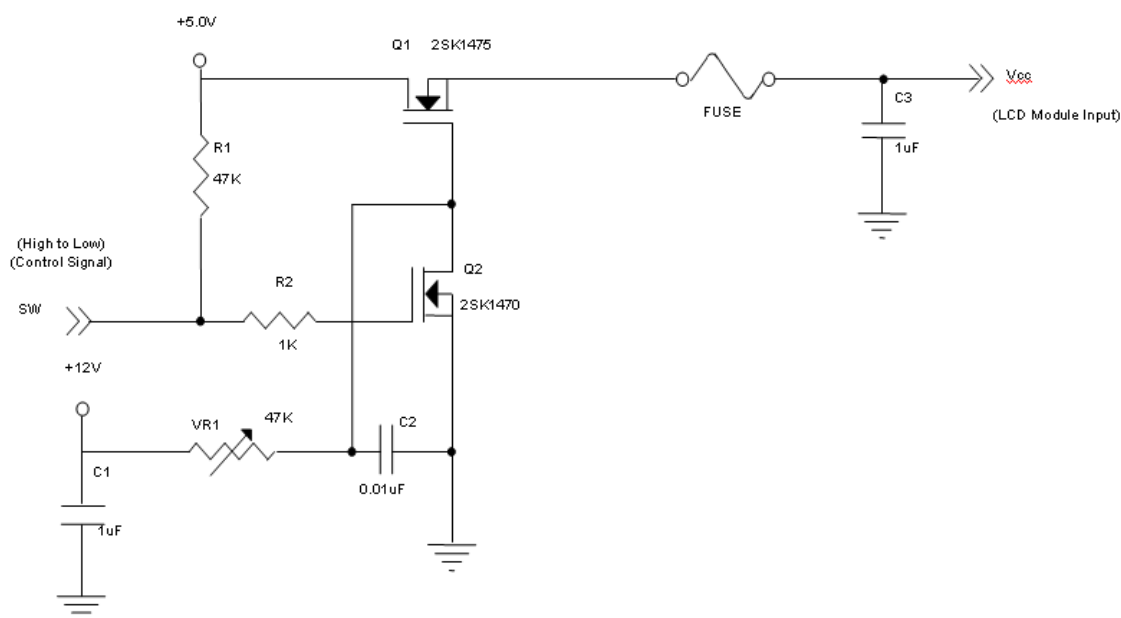

Vcc rising time is 470μs

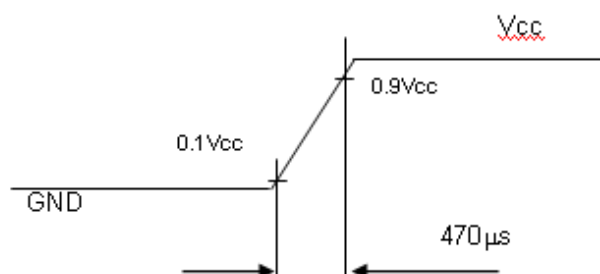

Note (3) The specified power supply current is under the conditions at $V_{cc} = 5.0\text{ V}$, $T_a = 25 \pm 2\text{ }^\circ\text{C}$, $F_r = 60\text{ Hz}$, whereas a power dissipation check pattern below is displayed.

a. White Pattern



Active Area

b. Black Pattern

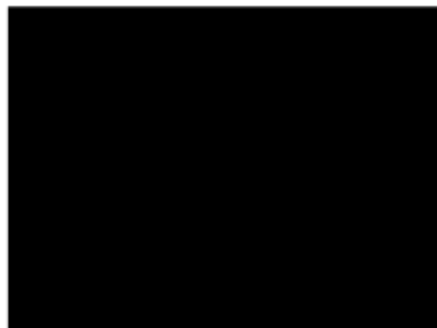

Active Area

c. Vertical Stripe Pattern

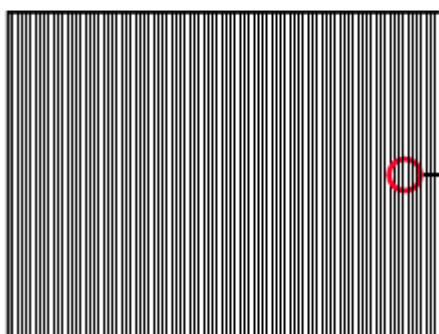

Active Area

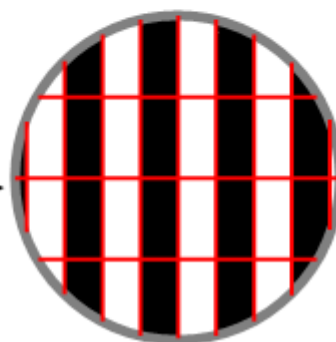

Note (4) The power consumption is specified at the pattern with the maximum current.

Note (5) VID waveform condition

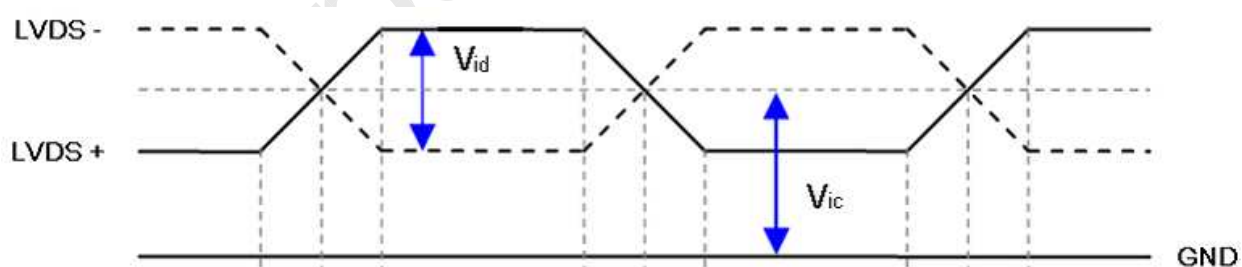

4.3.2 Vcc Power Dip Condition

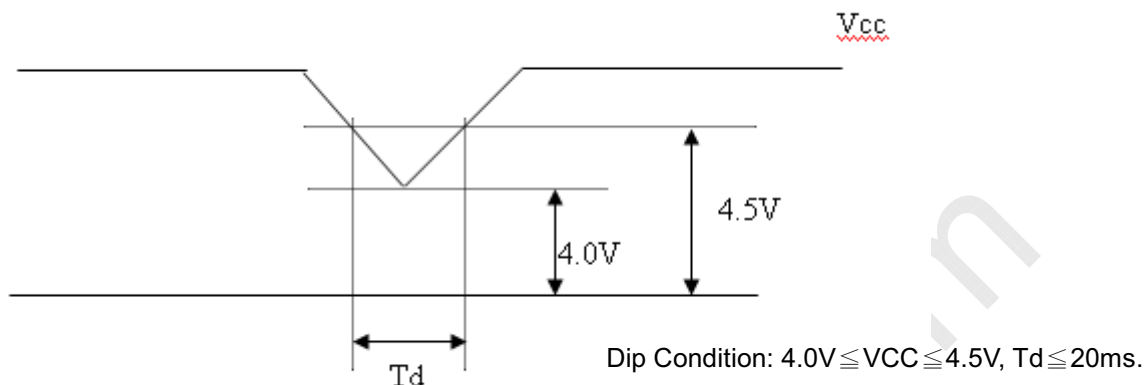

4.3.3 BACKLIGHT UNIT

| Parameter | Symbol | Value | | | Unit | Note |
|---|--------|-------|------|------|------|---------------------------------|
| | | Min. | Typ. | Max. | | |
| LED Light Bar Input Voltage Per Input Pin | VPIN | 11.2 | 12.6 | 13.6 | V | (1), Duty=100%, IPIN=65mA |
| LED Light Bar Current Per Input Pin | IPIN | 0 | 65 | 70 | mA | (1), (2) Duty=100% |
| LED Life Time | LLED | 30000 | | | Hrs | (3) |
| Power Consumption | PBL | --- | 6.55 | 7.07 | W | (1) Duty=100%, IPIN=65mA |

Note (1) LED light bar input voltage and current are measured by utilizing a true RMS multimeter as shown below:

Note (2) $PBL = IPIN \times VPIN \times (8)$ input pins

Note (3) The lifetime of LED is defined as the time when LED packages continue to operate under the conditions at $T_a = 25 \pm 2 \text{ }^\circ\text{C}$ and $I = (65)\text{mA}$ (per chip) until the brightness becomes $\leq 50\%$ of its original value.

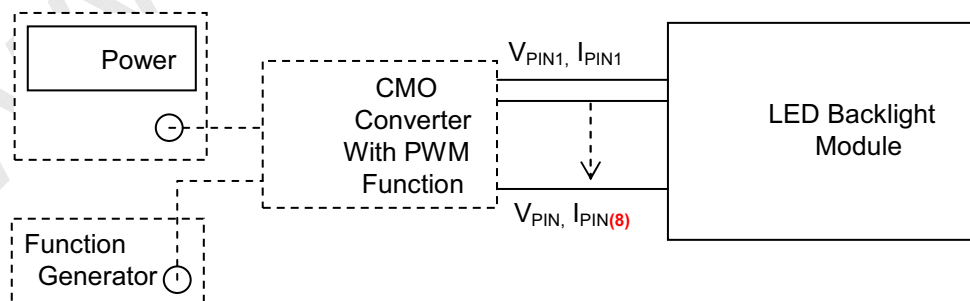

4.3.4 LIGHTBAR Connector Pin Assignment

Connector: 7083K-F12N-00L, (Entry) or Compatible

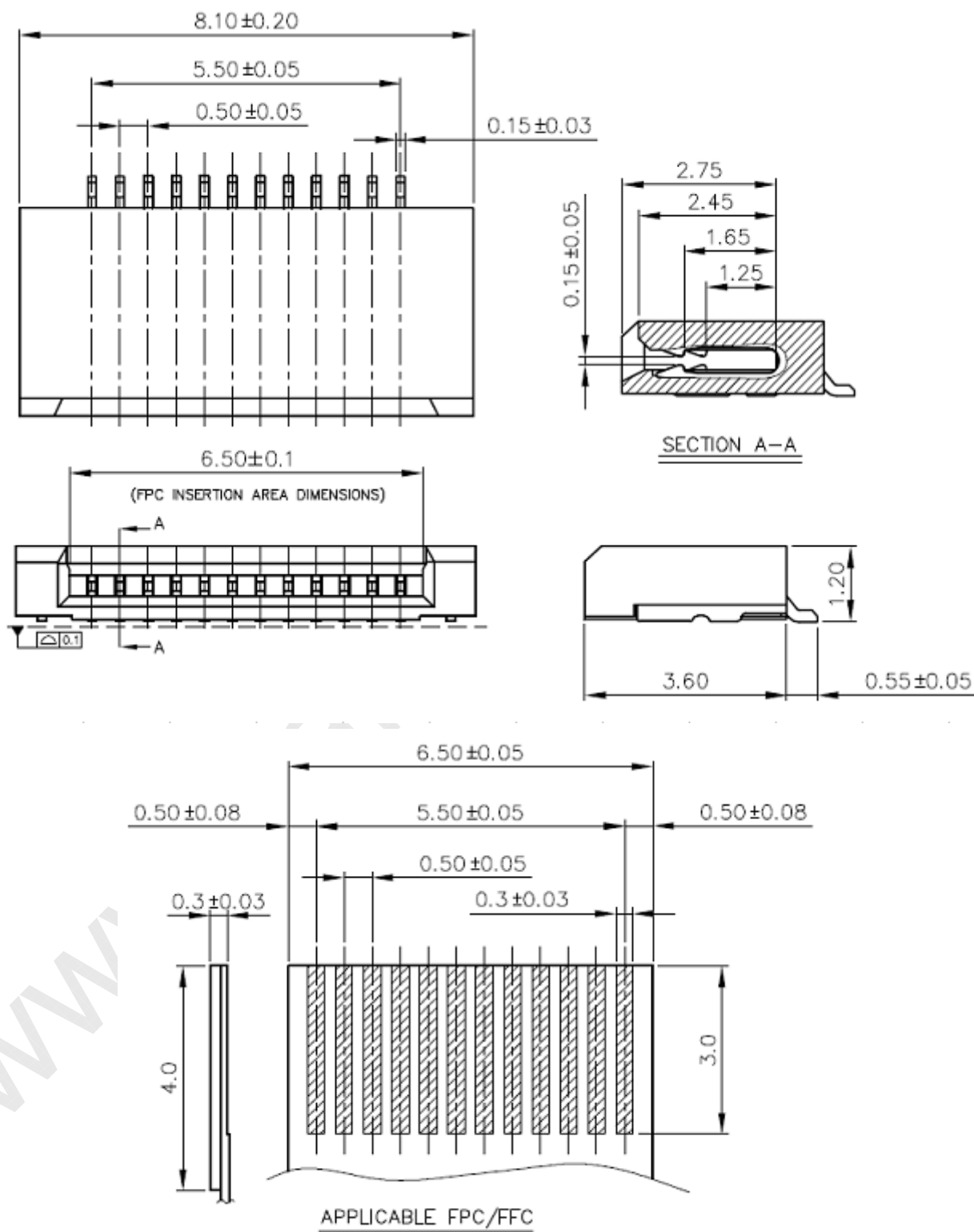

CN1

| Pin number | Description |
|------------|---|
| 1 | Cathode of LED string |
| 2 | Cathode of LED string |
| 3 | Cathode of LED string |
| 4 | Cathode of LED string |
| 5 | Not connection, this pin should be open |
| 6 | VLED |
| 7 | VLED |
| 8 | Not connection, this pin should be open |
| 9 | Cathode of LED string |
| 10 | Cathode of LED string |
| 11 | Cathode of LED string |
| 12 | Cathode of LED string |

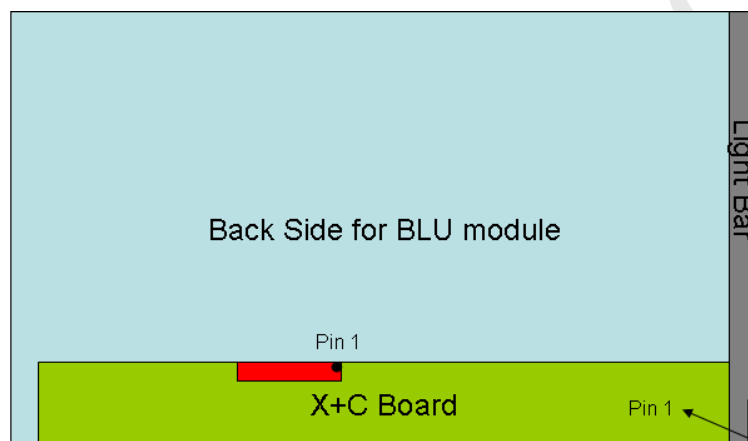

4.4 LVDS INPUT SIGNAL SPECIFICATIONS

4.4.1 LVDS DATA MAPPING TABLE

| | | | | | | | | |
|-----------------|-------------|-----|-----|-----|-----|-----|-----|-----|
| LVDS Channel O0 | LVDS output | D7 | D6 | D4 | D3 | D2 | D1 | D0 |
| | Data order | OG0 | OR5 | OR4 | OR3 | OR2 | OR1 | OR0 |
| LVDS Channel O1 | LVDS output | D18 | D15 | D14 | D13 | D12 | D9 | D8 |
| | Data order | OB1 | OB0 | OG5 | OG4 | OG3 | OG2 | OG1 |
| LVDS Channel O2 | LVDS output | D26 | D25 | D24 | D22 | D21 | D20 | D19 |
| | Data order | DE | NA | NA | OB5 | OB4 | OB3 | OB2 |
| LVDS Channel O3 | LVDS output | D23 | D17 | D16 | D11 | D10 | D5 | D27 |
| | Data order | NA | OB7 | OB6 | OG7 | OG6 | OR7 | OR6 |
| LVDS Channel E0 | LVDS output | D7 | D6 | D4 | D3 | D2 | D1 | D0 |
| | Data order | EG0 | ER5 | ER4 | ER3 | ER2 | ER1 | ER0 |
| LVDS Channel E1 | LVDS output | D18 | D15 | D14 | D13 | D12 | D9 | D8 |
| | Data order | EB1 | EB0 | EG5 | EG4 | EG3 | EG2 | EG1 |
| LVDS Channel E2 | LVDS output | D26 | D25 | D24 | D22 | D21 | D20 | D19 |
| | Data order | DE | NA | NA | EB5 | EB4 | EB3 | EB2 |
| LVDS Channel E3 | LVDS output | D23 | D17 | D16 | D11 | D10 | D5 | D27 |
| | Data order | NA | EB7 | EB6 | EG7 | EG6 | ER7 | ER6 |

4.4.2 COLOR DATA INPUT ASSIGNMENT

The brightness of each primary color (red, green and blue) is based on the 8-bit gray scale data input for the color. The higher the binary input, the brighter the color. The table below provides the assignment of color versus data input.

| Color | | Data Signal | | | | | | | | | | | | | | | | | | | | | | | |
|---------------------|-----------------|-------------|----|----|----|----|----|----|----|-------|----|----|----|----|----|----|----|------|----|----|----|----|----|----|----|
| | | Red | | | | | | | | Green | | | | | | | | Blue | | | | | | | |
| | | R7 | R6 | R5 | R4 | R3 | R2 | R1 | R0 | G7 | G6 | G5 | G4 | G3 | G2 | G1 | G0 | B7 | B6 | B5 | B4 | B3 | B2 | B1 | B0 |
| Basic Colors | Black | 0 | 0 | 0 | 0 | 0 | 0 | 0 | 0 | 0 | 0 | 0 | 0 | 0 | 0 | 0 | 0 | 0 | 0 | 0 | 0 | 0 | 0 | 0 | 0 |
| | Red | 1 | 1 | 1 | 1 | 1 | 1 | 1 | 1 | 0 | 0 | 0 | 0 | 0 | 0 | 0 | 0 | 0 | 0 | 0 | 0 | 0 | 0 | 0 | 0 |
| | Green | 0 | 0 | 0 | 0 | 0 | 0 | 0 | 0 | 1 | 1 | 1 | 1 | 1 | 1 | 1 | 1 | 0 | 0 | 0 | 0 | 0 | 0 | 0 | 0 |
| | Blue | 0 | 0 | 0 | 0 | 0 | 0 | 0 | 0 | 0 | 0 | 0 | 0 | 0 | 0 | 0 | 0 | 1 | 1 | 1 | 1 | 1 | 1 | 1 | 1 |
| | Cyan | 0 | 0 | 0 | 0 | 0 | 0 | 0 | 0 | 1 | 1 | 1 | 1 | 1 | 1 | 1 | 1 | 1 | 1 | 1 | 1 | 1 | 1 | 1 | 1 |
| | Magenta | 1 | 1 | 1 | 1 | 1 | 1 | 1 | 1 | 0 | 0 | 0 | 0 | 0 | 0 | 0 | 0 | 1 | 1 | 1 | 1 | 1 | 1 | 1 | 1 |
| | Yellow | 1 | 1 | 1 | 1 | 1 | 1 | 1 | 1 | 1 | 1 | 1 | 1 | 1 | 1 | 1 | 1 | 0 | 0 | 0 | 0 | 0 | 0 | 0 | 0 |
| | White | 1 | 1 | 1 | 1 | 1 | 1 | 1 | 1 | 1 | 1 | 1 | 1 | 1 | 1 | 1 | 1 | 1 | 1 | 1 | 1 | 1 | 1 | 1 | 1 |
| Gray Scale Of Red | Red(0) / Dark | 0 | 0 | 0 | 0 | 0 | 0 | 0 | 0 | 0 | 0 | 0 | 0 | 0 | 0 | 0 | 0 | 0 | 0 | 0 | 0 | 0 | 0 | 0 | |
| | Red(1) | 0 | 0 | 0 | 0 | 0 | 0 | 0 | 1 | 0 | 0 | 0 | 0 | 0 | 0 | 0 | 0 | 0 | 0 | 0 | 0 | 0 | 0 | 0 | |
| | Red(2) | 0 | 0 | 0 | 0 | 0 | 0 | 1 | 0 | 0 | 0 | 0 | 0 | 0 | 0 | 0 | 0 | 0 | 0 | 0 | 0 | 0 | 0 | 0 | |
| | ⋮ | ⋮ | ⋮ | ⋮ | ⋮ | ⋮ | ⋮ | ⋮ | ⋮ | ⋮ | ⋮ | ⋮ | ⋮ | ⋮ | ⋮ | ⋮ | ⋮ | ⋮ | ⋮ | ⋮ | ⋮ | ⋮ | ⋮ | ⋮ | |
| | ⋮ | ⋮ | ⋮ | ⋮ | ⋮ | ⋮ | ⋮ | ⋮ | ⋮ | ⋮ | ⋮ | ⋮ | ⋮ | ⋮ | ⋮ | ⋮ | ⋮ | ⋮ | ⋮ | ⋮ | ⋮ | ⋮ | ⋮ | ⋮ | |
| | Red(253) | 1 | 1 | 1 | 1 | 1 | 1 | 0 | 1 | 0 | 0 | 0 | 0 | 0 | 0 | 0 | 0 | 0 | 0 | 0 | 0 | 0 | 0 | 0 | |
| | Red(254) | 1 | 1 | 1 | 1 | 1 | 1 | 1 | 0 | 0 | 0 | 0 | 0 | 0 | 0 | 0 | 0 | 0 | 0 | 0 | 0 | 0 | 0 | 0 | |
| | Red(255) | 1 | 1 | 1 | 1 | 1 | 1 | 1 | 1 | 0 | 0 | 0 | 0 | 0 | 0 | 0 | 0 | 0 | 0 | 0 | 0 | 0 | 0 | 0 | |
| Gray Scale Of Green | Green(0) / Dark | 0 | 0 | 0 | 0 | 0 | 0 | 0 | 0 | 0 | 0 | 0 | 0 | 0 | 0 | 0 | 0 | 0 | 0 | 0 | 0 | 0 | 0 | 0 | |
| | Green(1) | 0 | 0 | 0 | 0 | 0 | 0 | 0 | 0 | 0 | 0 | 0 | 0 | 0 | 0 | 1 | 0 | 0 | 0 | 0 | 0 | 0 | 0 | 0 | |
| | Green(2) | 0 | 0 | 0 | 0 | 0 | 0 | 0 | 0 | 0 | 0 | 0 | 0 | 0 | 1 | 0 | 0 | 0 | 0 | 0 | 0 | 0 | 0 | 0 | |
| | ⋮ | ⋮ | ⋮ | ⋮ | ⋮ | ⋮ | ⋮ | ⋮ | ⋮ | ⋮ | ⋮ | ⋮ | ⋮ | ⋮ | ⋮ | ⋮ | ⋮ | ⋮ | ⋮ | ⋮ | ⋮ | ⋮ | ⋮ | ⋮ | |
| | ⋮ | ⋮ | ⋮ | ⋮ | ⋮ | ⋮ | ⋮ | ⋮ | ⋮ | ⋮ | ⋮ | ⋮ | ⋮ | ⋮ | ⋮ | ⋮ | ⋮ | ⋮ | ⋮ | ⋮ | ⋮ | ⋮ | ⋮ | ⋮ | |
| | Green(253) | 0 | 0 | 0 | 0 | 0 | 0 | 0 | 0 | 1 | 1 | 1 | 1 | 1 | 1 | 0 | 1 | 0 | 0 | 0 | 0 | 0 | 0 | 0 | |
| | Green(254) | 0 | 0 | 0 | 0 | 0 | 0 | 0 | 0 | 1 | 1 | 1 | 1 | 1 | 1 | 1 | 0 | 0 | 0 | 0 | 0 | 0 | 0 | 0 | |
| | Green(255) | 0 | 0 | 0 | 0 | 0 | 0 | 0 | 0 | 1 | 1 | 1 | 1 | 1 | 1 | 1 | 1 | 0 | 0 | 0 | 0 | 0 | 0 | 0 | |
| Gray Scale Of Blue | Blue(0) / Dark | 0 | 0 | 0 | 0 | 0 | 0 | 0 | 0 | 0 | 0 | 0 | 0 | 0 | 0 | 0 | 0 | 0 | 0 | 0 | 0 | 0 | 0 | 0 | |
| | Blue(1) | 0 | 0 | 0 | 0 | 0 | 0 | 0 | 0 | 0 | 0 | 0 | 0 | 0 | 0 | 0 | 0 | 0 | 0 | 0 | 0 | 0 | 0 | 1 | |
| | Blue(2) | 0 | 0 | 0 | 0 | 0 | 0 | 0 | 0 | 0 | 0 | 0 | 0 | 0 | 0 | 0 | 0 | 0 | 0 | 0 | 0 | 0 | 1 | 0 | |
| | ⋮ | ⋮ | ⋮ | ⋮ | ⋮ | ⋮ | ⋮ | ⋮ | ⋮ | ⋮ | ⋮ | ⋮ | ⋮ | ⋮ | ⋮ | ⋮ | ⋮ | ⋮ | ⋮ | ⋮ | ⋮ | ⋮ | ⋮ | ⋮ | |
| | ⋮ | ⋮ | ⋮ | ⋮ | ⋮ | ⋮ | ⋮ | ⋮ | ⋮ | ⋮ | ⋮ | ⋮ | ⋮ | ⋮ | ⋮ | ⋮ | ⋮ | ⋮ | ⋮ | ⋮ | ⋮ | ⋮ | ⋮ | ⋮ | |
| | Blue(253) | 0 | 0 | 0 | 0 | 0 | 0 | 0 | 0 | 0 | 0 | 0 | 0 | 0 | 0 | 0 | 1 | 1 | 1 | 1 | 1 | 1 | 1 | 0 | |
| | Blue(254) | 0 | 0 | 0 | 0 | 0 | 0 | 0 | 0 | 0 | 0 | 0 | 0 | 0 | 0 | 0 | 1 | 1 | 1 | 1 | 1 | 1 | 1 | 0 | |
| | Blue(255) | 0 | 0 | 0 | 0 | 0 | 0 | 0 | 0 | 0 | 0 | 0 | 0 | 0 | 0 | 0 | 1 | 1 | 1 | 1 | 1 | 1 | 1 | 1 | |

Note (1) 0: Low Level Voltage, 1: High Level Voltage

4.5 DISPLAY TIMING SPECIFICATIONS

The input signal timing specifications are shown as the following table and timing diagram.

| Signal | Item | Symbol | Min. | Typ. | Max. | Unit | Note |
|-------------------------|--------------------------------------|-------------------------|----------------------------------|-------|----------------------------------|----------------|---|
| LVDS Clock | Frequency | F _c | 58.54 | 74.25 | 97.98 | MHz | - |
| | Period | T _c | - | 13.47 | - | ns | |
| | Input cycle to cycle jitter | T _{rcl} | - | - | 200 | ns | (1) |
| | Input Clock to data skew | TLVCCS | | | 400 | ps | (2) |
| | Spread spectrum modulation range | F _{clk_in_mod} | F _c *98% | | F _c *102% | MHz | (3) |
| | Spread spectrum modulation frequency | F _{SSM} | | | 200 | KHz | |
| Vertical Display Term | Frame Rate | Fr | 50 | 60 | 75 | Hz | T _v =T _v d+T _v b |
| | Total | T _v | 1115 | 1125 | 1136 | Th | - |
| | Active Display | T _v d | 1080 | 1080 | 1080 | Th | - |
| | Blank | T _v b | T _v -T _v d | 45 | T _v -T _v d | Th | - |
| Horizontal Display Term | Total | T _h | 1050 | 1100 | 1150 | T _c | T _h =T _h d+T _h b |
| | Active Display | T _h d | 960 | 960 | 960 | T _c | - |
| | Blank | T _h b | T _h -T _h d | 140 | T _h -T _h d | T _c | - |

Note: Because this module is operated by DE only mode, Hsync and Vsync input signals are ignored.

INPUT SIGNAL TIMING DIAGRAM

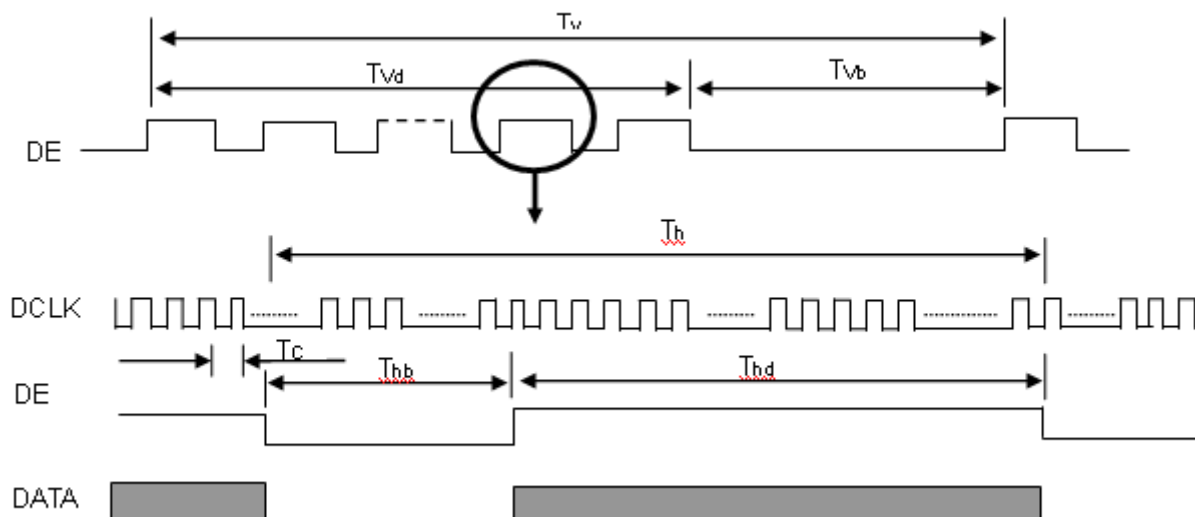

Note (1) The input clock cycle-to-cycle jitter is defined as below figures. $Trcl = |T_1 - T_1'|$

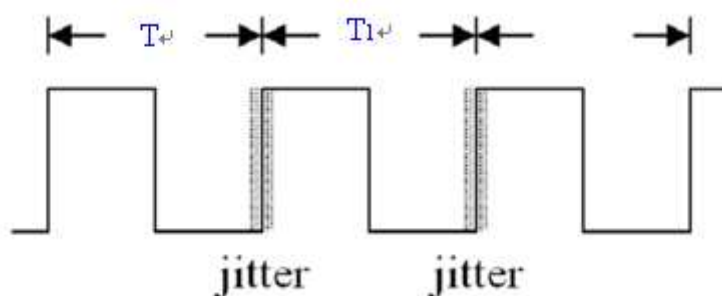

Note (2) Input Clock to data skew is defined as below figures.

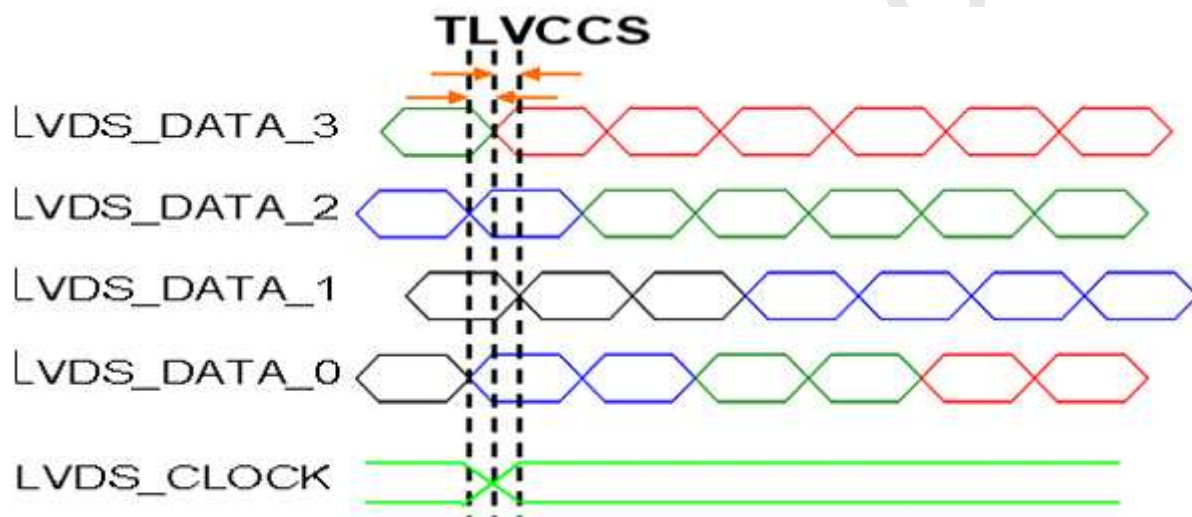

Note (3) The SSCG (Spread spectrum clock generator) is defined as below figures.

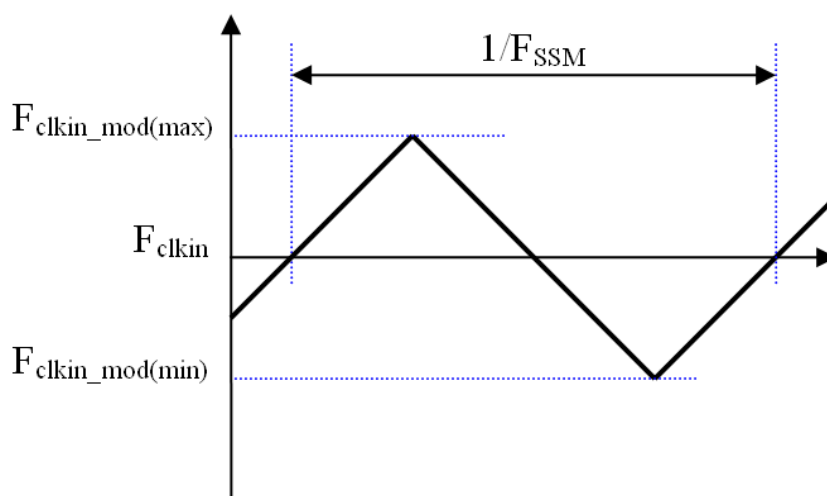

4.6 POWER ON/OFF SEQUENCE

The power sequence specifications are shown as the following table and diagram.

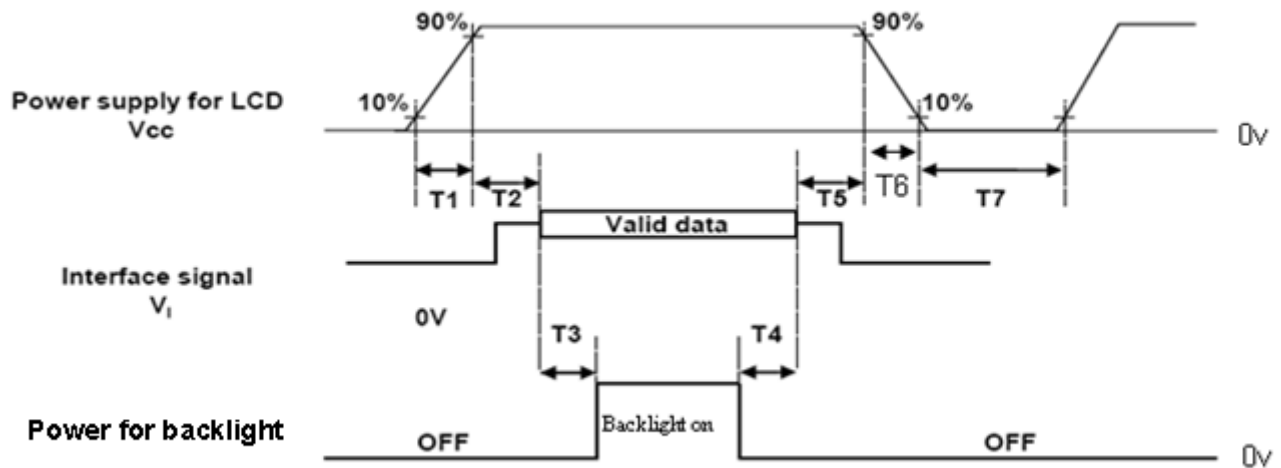

Timing Specifications:

| Parameters | Values | | | Units |
|------------|--------|------|-----|-------|
| | Min | Typ. | Max | |
| T1 | 0.5 | - | 10 | ms |
| T2 | 0 | - | 50 | ms |
| T3 | 450 | - | - | ms |
| T4 | 90 | - | - | ms |
| T5 | 0 | - | 50 | ms |
| T6 | 5 | - | 100 | ms |
| T7 | 500 | - | - | ms |

Note (1) The supply voltage of the external system for the module input should be the same as the definition of Vcc.

Note (2) When the backlight turns on before the LCD operation of the LCD turns off, the display may momentarily become abnormal screen.

Note (3) In case of VCC = off level, please keep the level of input signals on the low or keep a high impedance.

Note (4) T4 should be measured after the module has been fully discharged between power off and on period.

Note (5) Interface signal shall not be kept at high impedance when the power is on.

Note (6) CMO won't take any responsibility for the products which are damaged by the customers not following the Power Sequence.

Note (7) There might be slight electronic noise when LCD is turned off (even backlight unit is also off). To avoid this symptom, we suggest "Vcc falling timing" to follow "t6 spec".

5. OPTICAL CHARACTERISTICS

5.1 TEST CONDITIONS

| Item | Symbol | Value | Unit |
|---|---|---------------|------------------|
| Ambient Temperature | Ta | 25±2 | °C |
| Ambient Humidity | Ha | 50±10 | %RH |
| Supply Voltage | V _{CC} | 5 | V |
| Input Signal | According to typical value in "3. ELECTRICAL CHARACTERISTICS" | | |
| LED Light Bar Input Current Per Input Pin | I _{PIN} | 65 ± 2 | mA _{DC} |
| PWM Duty Ratio | D | 100 | % |
| LED Light Bar Test Converter | 35-D064562 | | |

5.2 OPTICAL SPECIFICATIONS

The relative measurement methods of optical characteristics are shown in 5.2. The following items should be measured under the test conditions described in 5.1 and stable environment shown in Note (5).

| Item | Symbol | Condition | Min. | Typ. | Max. | Unit | Note | |
|--|----------------|--------------------------------------|--|---------------|---------|-------------------|----------|----------|
| Color Chromaticity (CIE 1931) | Red | Rx | $\theta_x=0^\circ, \theta_y=0^\circ$ CS-2000 R=G=B=255 Gray scale | Typ - 0.03 | (0.643) | Typ + 0.03 | - | (1), (5) |
| | | Ry | | | (0.340) | | | |
| | Green | Gx | | | (0.311) | | | |
| | | Gy | | | (0.625) | | | |
| | Blue | Bx | | | (0.155) | | | |
| | | By | | | (0.061) | | | |
| | White | Wx | | | (0.313) | | | |
| | | Wy | | | (0.329) | | | |
| Center Luminance of White (Center of Screen) | L _c | | 200 | 250 | - | cd/m ² | (4), (5) | |
| Contrast Ratio | CR | | 700 | 1000 | - | - | (2), (5) | |
| Response Time | T _R | $\theta_x=0^\circ, \theta_y=0^\circ$ | - | 1.5 | 2.5 | ms | (3) | |
| | T _F | | - | 3.5 | 5.5 | | | |
| White Variation | δW | $\theta_x=0^\circ, \theta_y=0^\circ$ | 75 | - | - | -% | (5), (6) | |
| Viewing Angle | Horizontal | θ _{x-} + θ _{x+} | CR ≥ 10 | 150 | 170 | - | Deg. | (1), (5) |
| | Vertical | θ _{y-} + θ _{y+} | | 140 | 160 | - | | |
| Viewing Angle | Horizontal | θ _{x-} + θ _{x+} | CR ≥ 5 | 160 | 178 | --- | Deg. | (1), (5) |
| | Vertical | θ _{y-} + θ _{y+} | | 150 | 170 | --- | | |

Note (1) Definition of Viewing Angle (θ_x , θ_y):

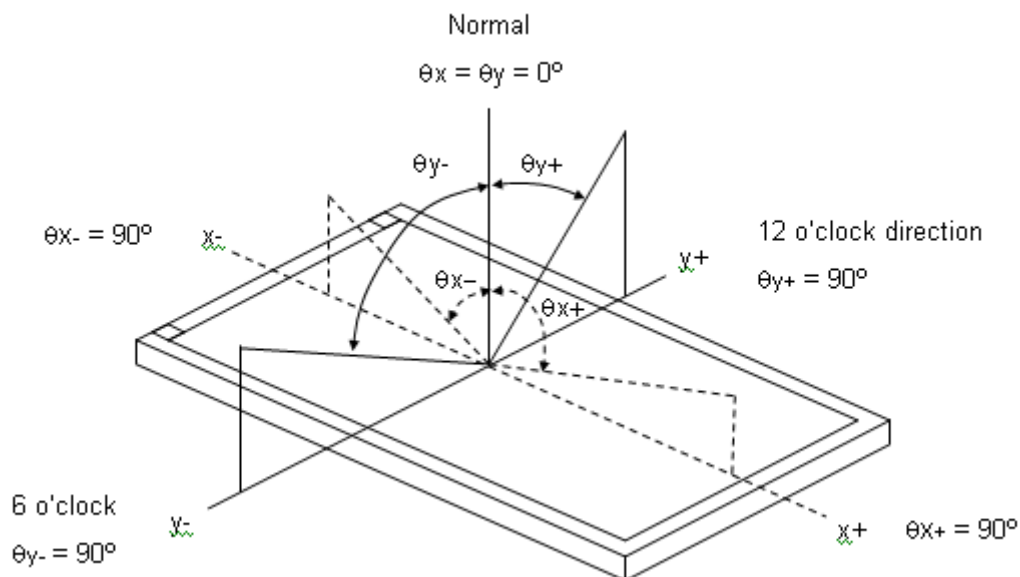

Note (2) Definition of Contrast Ratio (CR):

The contrast ratio can be calculated by the following expression.

$$\text{Contrast Ratio (CR)} = L_{255} / L_0$$

L255: Luminance of gray level 255

L 0: Luminance of gray level 0

$$\text{CR} = \text{CR} (5)$$

CR (X) is corresponding to the Contrast Ratio of the point X at Figure in Note (6).

Note (3) Definition of Response Time (T_R , T_F):

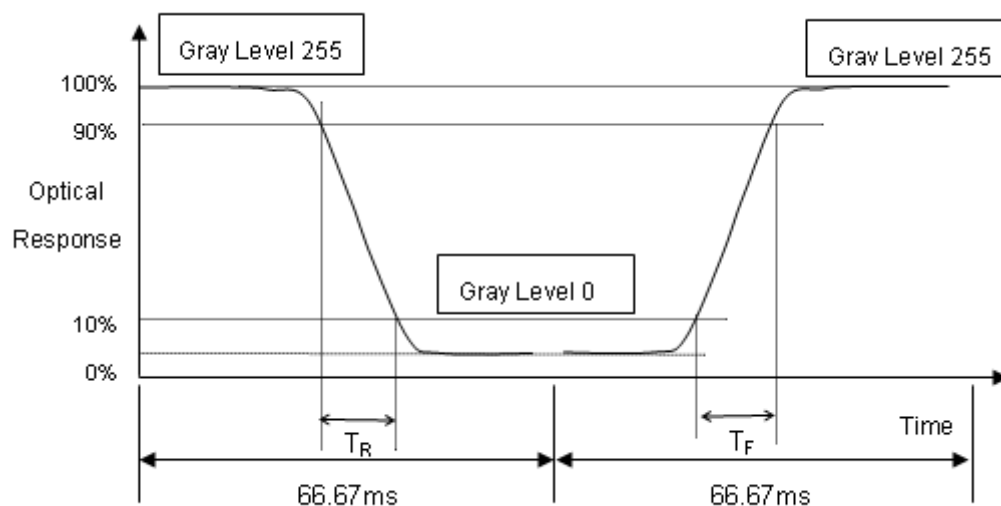

Note (4) Definition of Luminance of White (L_c):

Measure the luminance of gray level 255 at center point

$$L_c = L(5)$$

$L(x)$ is corresponding to the luminance of the point X at Figure in Note (6).

Note (5) Measurement Setup:

The LCD module should be stabilized at given temperature for 40 minutes to avoid abrupt temperature change during measuring. In order to stabilize the luminance, the measurement should be executed after lighting Backlight for 40 minutes in a windless room.

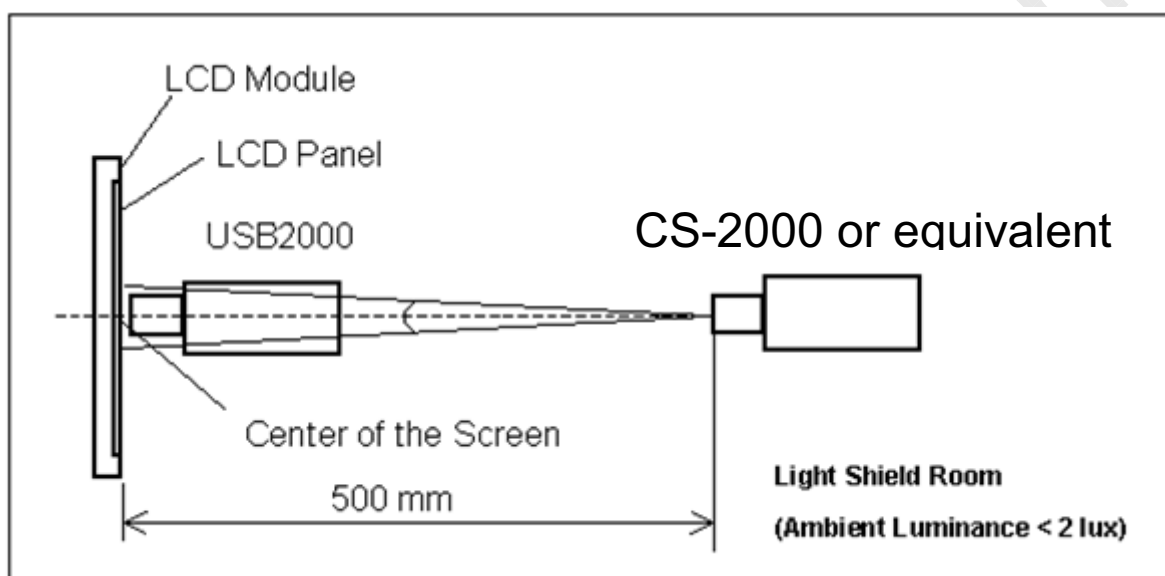

Note (6) Definition of White Variation (δW):

Measure the luminance of gray level 255 at 9 points

$$\delta W = (\text{Minimum } [L(1) \sim L(9)] / \text{Maximum } [L(1) \sim L(9)]) * 100\%$$

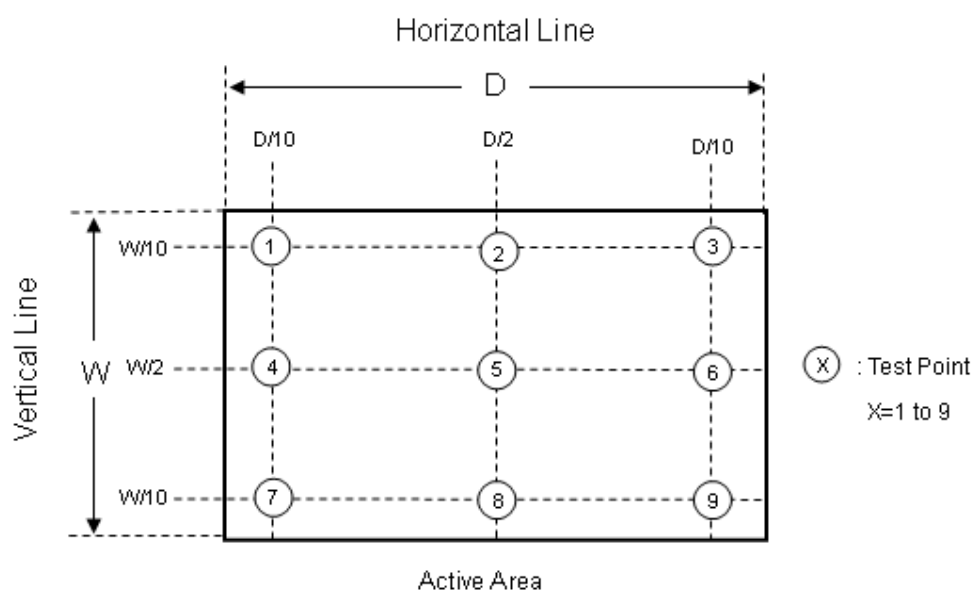

6. RELIABILITY TEST ITEM

| Items | Required Condition | Note |
|----------------------------------|---|------|
| Temperature Humidity Bias (THB) | Ta= 50°C , 80%RH, 240hours | |
| High Temperature Operation (HTO) | Ta= 50°C , 50%RH , 240hours | |
| Low Temperature Operation (LTO) | Ta= 0°C , 240hours | |
| High Temperature Storage (HTS) | Ta= 60°C , 240hours | |
| Low Temperature Storage (LTS) | Ta= -20°C , 240hours | |
| Vibration Test (Non-operation) | Acceleration: 1.5 Grms Wave: Half-sine Frequency: 10 - 300 Hz Sweep: 30 Minutes each Axis (X, Y, Z) | |
| Shock Test (Non-operation) | Acceleration: 50 G Wave: Half-sine Active Time: 11 ms Direction : ± X, ± Y, ± Z.(one time for each Axis) | |
| Thermal Shock Test (TST) | -20°C/30min , 60°C / 30min , 100 cycles | |
| On/Off Test | 25°C , On/10sec , Off /10sec , 30,000 cycles | |
| ESD (Electro Static Discharge) | Contact Discharge: ± 8KV, 150pF(330Ω) | |
| | Air Discharge: ± 15KV, 150pF(330Ω) | |
| Altitude Test | Operation:10,000 ft / 24hours Non-Operation:30,000 ft / 24hours | |

Note (1) criteria : Normal display image with no obvious non-uniformity and no line defect.

Note (2) Evaluation should be tested after storage at room temperature for more than two hour

Note (3) At testing Vibration and Shock, the fixture in holding the module has to be hard and rigid enough so that the module would not be twisted or bent by the fixture.

The fixing condition is shown as below:

At Room Temperature

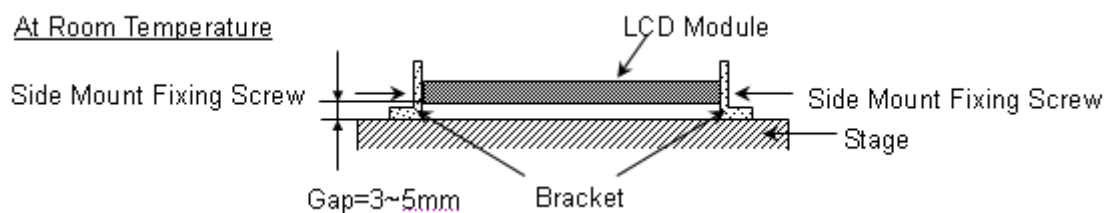

7. PACKING

7.1 PACKING SPECIFICATIONS

- (1) 10 LCD modules / 1 Box
- (2) Box dimensions: 567(L) X 301(W) X 376(H) mm
- (3) Weight: approximately: 19.92 kg (10 modules per box)

7.2 PACKING METHOD

- (1) Carton Packing should have no failure in the following reliability test items.

| Test Item | Test Conditions | Note |
|---------------|--|------|
| Vibration | ISTA STANDARD Random, Frequency Range: 5 – 200 Hz Top & Bottom: 15 minutes (+Z), 15 min (-Z), Right & Left: 10 minutes (X) Back & Forth 10 minutes (Y) | PASS |
| Dropping Test | 1 Corner , 3 Edge, 6 Face, 46cm | PASS |

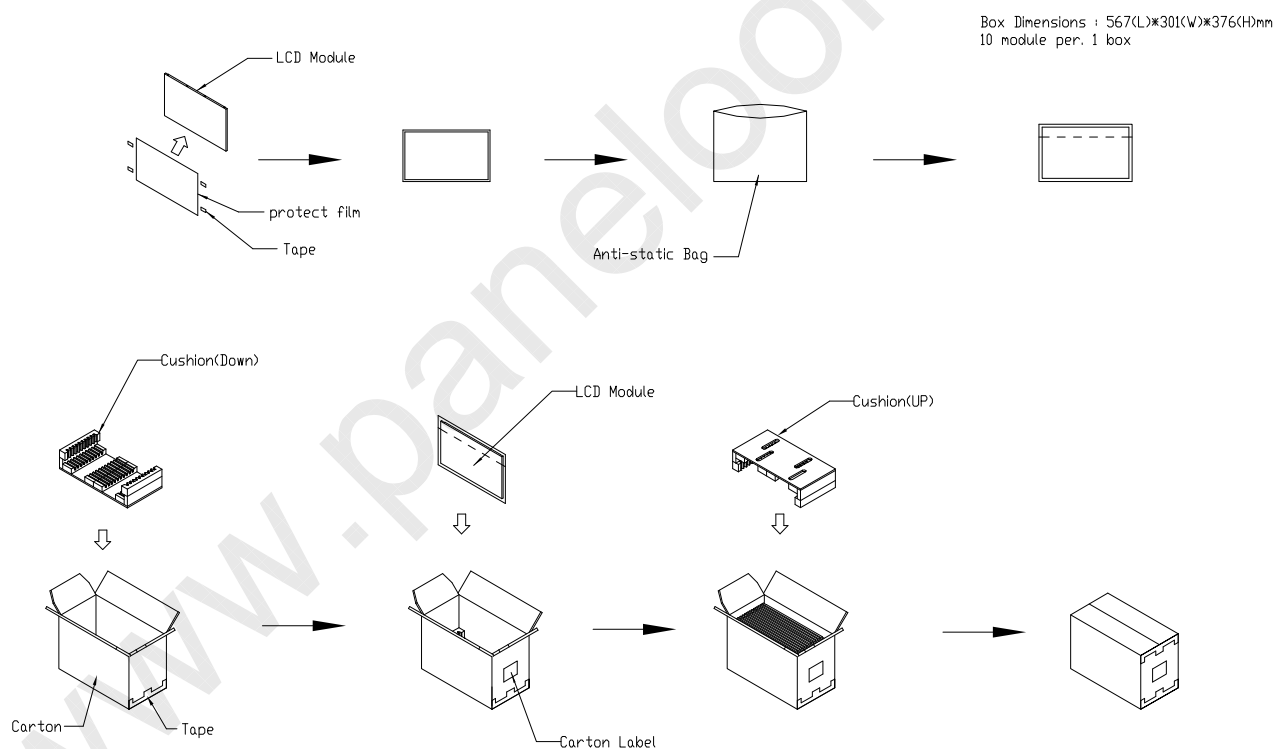
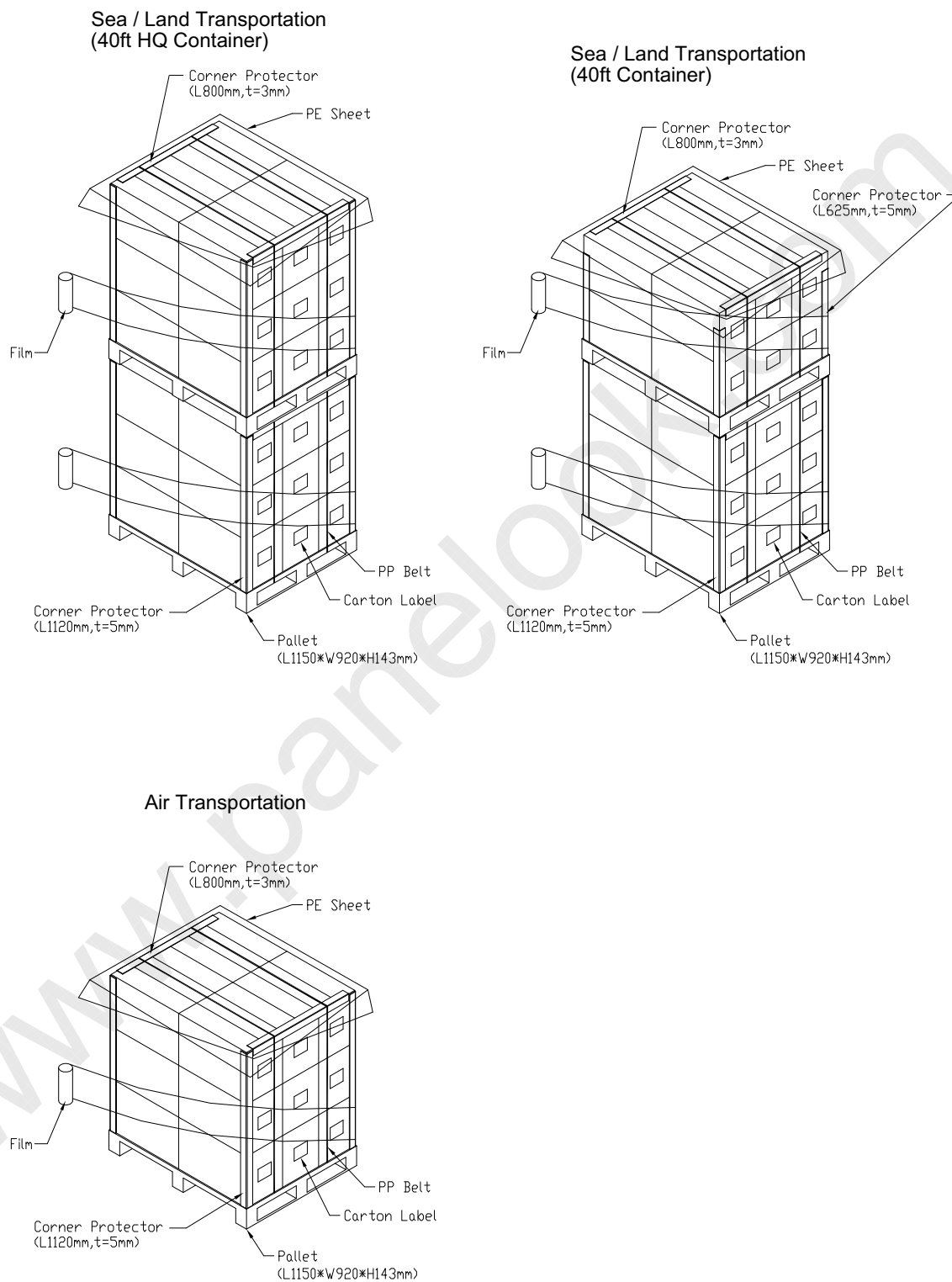

Figure. 7-1 Packing method

7.3 PALLET

Figure. 7-2 Packing method

8. CMI MODULE LABEL

The barcode nameplate is pasted on each module as illustration, and its definitions are as following explanation.



(a) Model Name: M215HGJ-L21

(b) Revision: Rev. XX, for example: A0, A1... B1, B2... or C1, C2...etc.

(c) CMI barcode definition:

Serial ID: XX-XX-X-XX-YMD-L-NNNN

| Code | Meaning | Description |
|------|------------------|---|
| XX | CMI internal use | - |
| XX | Revision | Cover all the change |
| X | CMI internal use | - |
| XX | CMI internal use | - |
| YMD | Year, month, day | Year: 0~9, 2001=1, 2002=2, 2003=3...2010=0, 2011=1, 2012=2... Month: 1~12=1, 2, 3, ~, 9, A, B, C Day: 1~31=1, 2, 3, ~, 9, A, B, C, ~, W, X, Y, exclude I, O, and U. |
| L | Product line # | Line 1=1, Line 2=2, Line 3=3, ... |
| NNNN | Serial number | Manufacturing sequence of product |

(d) Customer's barcode definition:

Serial ID: CM- L5J21-X-X-X-XX-L-XX-L-YMD-NNNN

| Code | Meaning | Description |
|-------|-----------------------|---|
| CM | Supplier code | CMO=CM |
| L5J21 | Model number | M215HGJ-L21= L5J21 |
| X | Revision code | Non ZBD: 1,2,~,8,9 / ZBD: A~Z |
| X | Source driver IC code | Century=1, CLL=2, Demos=3, Epson=4, Fujitsu=5, Himax=6, Hitachi=7, Hynix=8, LDI=9, Matsushita=A, NEC=B, Novatec=C, OKI=D, Philips=E, Renesas=F, Samsung=G, Sanyo=H, Sharp=I, TI=J, Topro=K, Toshiba=L, Windbond=M |
| X | Gate driver IC code | |
| XX | Cell location | Tainan Taiwan=TN, Ningbo China=CN |
| L | Cell line # | 1,2,~,9,A,B,~,Y,Z |
| XX | Module location | Tainan, Taiwan=TN ; Ningbo China=NP |
| L | Module line # | 1,2,~,9,A,B,~,Y,Z |
| YMD | Year, month, day | Year: 0~9, 2001=1, 2002=2, 2003=3...2010=0, 2011=1, 2012=2... Month: 1~12=1, 2, 3, ~, 9, A, B, C Day: 1~31=1, 2, 3, ~, 9, A, B, C, ~, T, U, V |
| NNNN | Serial number | By LCD supplier |

(e) FAB ID(UL Factory ID):

| Region | Factory ID |
|--------|------------|
| TWCMO | GEMN |
| NBCMO | LEOO |
| NBCME | CANO |
| NHCMO | CAPG |

9. PRECAUTIONS

9.1 ASSEMBLY AND HANDLING PRECAUTIONS

- (1) Do not apply rough force such as bending or twisting to the module during assembly.
- (2) To assemble or install module into user's system can be only in clean working areas. The dust and oil may cause electrical short or worsen the polarizer.
- (3) It's not permitted to have pressure or impulse on the module because the LCD panel and Backlight will be damaged.
- (4) Always follow the correct power sequence when LCD module is connecting and operating. This can prevent damage to the CMOS LSI chips during latch-up.
- (5) Do not pull the I/F connector in or out while the module is operating.
- (6) Do not disassemble the module.
- (7) Use a soft dry cloth without chemicals for cleaning, because the surface of polarizer is very soft and easily scratched.
- (8) It is dangerous that moisture come into or contacted the LCD module, because moisture may damage LCD module when it is operating.
- (9) High temperature or humidity may reduce the performance of module. Please store LCD module within the specified storage conditions.
- (10) When ambient temperature is lower than 10°C may reduce the display quality. For example, the response time will become slowly.

9.2 STORAGE PRECAUTIONS

- (1) Do not leave the module in high temperature, and high humidity for a long time. It is highly recommended to store the module with temperature from 0°C to 35°C and relative humidity of less than 70%
- (2) Do not store the TFT – LCD module in direct sunlight
- (3) The module should be stored in dark place. It is prohibited to apply sunlight or fluorescent light in storing

9.3 OPERATION PRECAUTIONS

- (1) The LCD product should be operated under normal condition.
Normal condition is defined as below :
Temperature : 20±15°C
Humidity: 65±20%
Display pattern : continually changing pattern(Not stationary)
- (2) If the product will be used in extreme conditions such as high temperature, high humidity, high altitude, display pattern or operation time etc... It is strongly recommended to contact CMO for application engineering advice. Otherwise, its reliability and function may not be guaranteed.

9.4 SAFETY PRECAUTIONS

- (1) If the liquid crystal material leaks from the panel, it should be kept away from the eyes or mouth. In case of contact with hands, skin or clothes, it has to be washed away thoroughly with soap.
- (2) After the module's end of life, it is not harmful in case of normal operation and storage.

9.5 SAFETY STANDARDS

The LCD module should be certified with safety regulations as follows:

- (1) UL60950-1 or updated standard.
- (2) IEC60950-1 or updated standard.

9.6 OTHER

When fixed patterns are displayed for a long time, remnant image is likely to occur.

Appendix. OUTLINE DRAWING

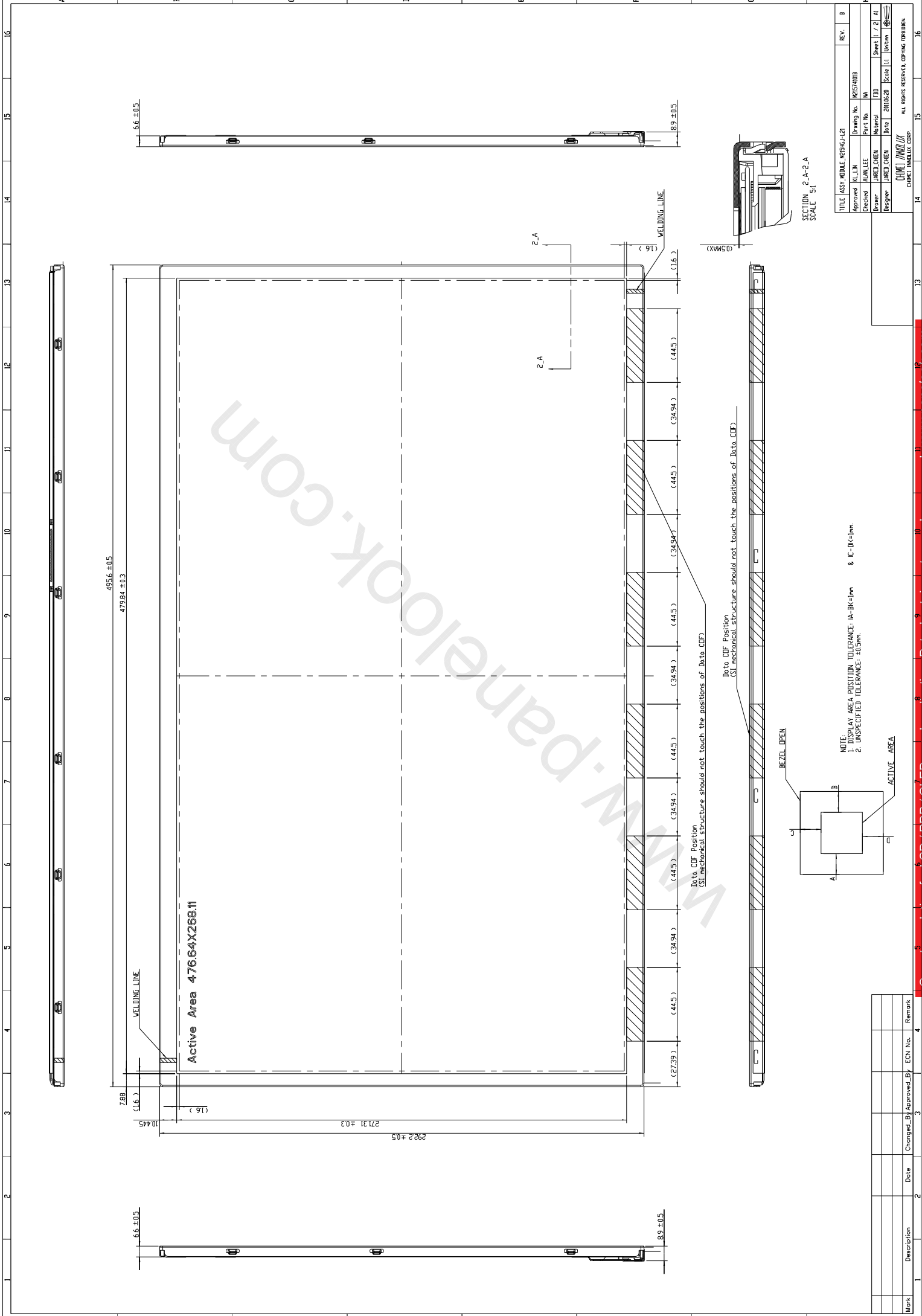

SECTION 2-A-2-A
SCALE 5:1

| REV. | B |
|-------------|------------|
| Approved | K.LIN |
| Checked | ALAN LEE |
| Drawn | JARED CHEN |
| Designer | JARED CHEN |
| Drawing No. | WDS14018 |
| Part No. | NA |
| Material | |
| Date | 2010.02.20 |
| Sheet 11 | 1 of 21 |
| Section 11 | 1 of 1 |

CHINESE MANUFACTURE
ALL RIGHTS RESERVED. COPYING PROHIBITED.

NOTE:
1. DISPLAY AREA POSITION TOLERANCE: ± 0.1 mm & IC-DIV ≤ 1 mm
2. UNSPECIFIED TOLERANCE: ± 0.2 mm.

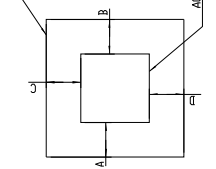

Data CDF Position
(SI mechanical structure should not touch the positions of Data CDF)

Data CDF Position
(SI mechanical structure should not touch the positions of Data CDF)

| Work | Description | Date | Changed By | ECN No. | Remark |
|------|-------------|------|------------|---------|--------|
| | | | | | |
| | | | | | |

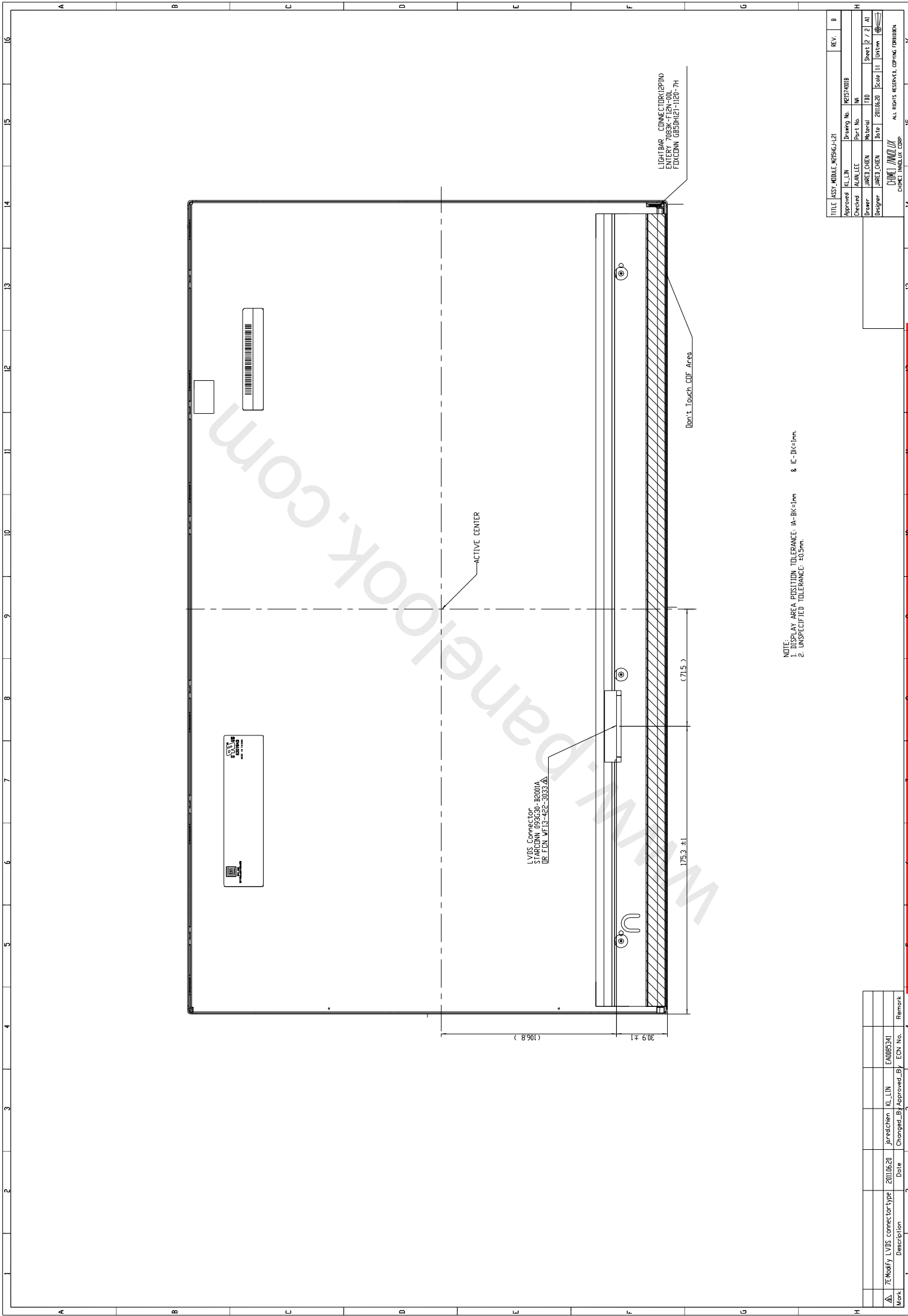

NOTE:
 1. DISPLAY AREA POSITION TOLERANCE: 0.1mm & IC-DIC=1mm
 2. UNSPECIFIED TOLERANCE: 0.05mm

| REV. | B |
|----------|------------|
| Approved | KL_LIN |
| Checked | KLAL_LIC |
| Drawn | JARED_CHEN |
| Designer | JARED_CHEN |
| Part No. | MA |
| Material | FR0 |
| Date | 2011.05.20 |
| Scale | 1:1 |
| System | 1000 |

| Work | Description | Date | Changed By | Approved By | CN No. | Remark |
|------|-------------------------------|------------|------------|-------------|----------|--------|
| Δ | TE Modify LVDS connector type | 2011.05.20 | Jared Chen | KL_LIN | E0085341 | |