



# Product Specification

M215HTN01.0

AU OPTRONICS CORPORATION

( ) Preliminary Specification

( V ) Final Specification

<b>Module</b>	21.5" Color TFT-LCD
<b>Model Name</b>	M215HTN01.0

Customer	Date
_____	_____
<b>Approved by</b>	
_____	_____
Note: This Specification is subject to change without notice.	

Approved by	Date
<u>Howard Lee</u>	<u>2012/10/15</u>
<b>Prepared by</b>	
<u>Vincent Chan</u>	<u>2012/10/15</u>
AU Optronics Corporation	



# Product Specification

M215HTN01.0

AU OPTRONICS CORPORATION

## Content

<b>1 HANDLING PRECAUTIONS</b> .....	<b>6</b>
<b>2 GENERAL DESCRIPTION</b> .....	<b>7</b>
2.1 Display Characteristics .....	7
2.2 Optical Characteristics.....	8
<b>3 FUNCTIONAL BLOCK DIAGRAM</b> .....	<b>12</b>
<b>4 ABSOLUTE MAXIMUM RATINGS</b> .....	<b>13</b>
4.1 TFT LCD Module .....	13
4.2 Backlight Unit .....	13
4.3 Absolute Ratings of Environment .....	13
<b>5 ELECTRICAL CHARACTERISTICS</b> .....	<b>15</b>
5.1 TFT LCD Module .....	15
5.1.1 Power Specification .....	15
5.1.2 Signal Electrical Characteristics .....	16
5.2 Backlight Unit .....	18
<b>6 SIGNAL CHARACTERISTICS</b> .....	<b>19</b>
6.1 Pixel Format Definition .....	19
6.2 Input Data Format Definition .....	19
6.3 Signal Description.....	20
6.4 Timing Characteristics.....	22
6.5 Timing Diagram.....	23
6.6 Power ON/OFF Sequence.....	24
<b>7 CONNECTOR AND PIN ASSIGNMENT</b> .....	<b>25</b>
7.1 TFT LCD Module .....	25
7.1.1 Pin Assignment.....	25
7.2 LED Connector on Backlight Unit .....	26
7.2.1 LED Pin assignment.....	26
7.2.2 LED Connector Dimension .....	27
7.2.3 LED Mating housing dimension.....	27
<b>8 RELIABILITY TEST</b> .....	<b>28</b>
<b>9 SHIPPING LABEL</b> .....	<b>30</b>
<b>10 MECHANICAL CHARACTERISTICS</b> .....	錯誤! 尚未定義書籤。
<b>11 PACKING SPECIFICATION</b> .....	錯誤! 尚未定義書籤。
11.1 Packing Flow.....	錯誤! 尚未定義書籤。
11.2 Pallet and Shipment Information .....	錯誤! 尚未定義書籤。



# Product Specification

M215HTN01.0

AU OPTRONICS CORPORATION

## Records of Revision

Version and Date	Page	Old description	New Description	Remark
0.1 2011/12/07	All	First Edition for Customer		
0.2 2012/1/9	7		Add Response Time / Gray to Gray(16x16 avg.)	
0.2 2012/1/9	7		Correct Color / Chromaticity Coordinates (CIE)	
0.2 2012/1/9	12	Backligh Unit / CCFL Current	Backlight Unit / LED Forward Current , LED Pulse Forward Current , LED forward Voltage variation (per string variation)	
0.2 2012/1/9	12		Add Note 5: IRLED1,2,3,4 and IPLED1,2,3,4 define as per strings LED current.	
0.2 2012/1/9	17	Symbol / IRLED	Symbol / IRLED1, IRLED2, IRLED3, IRLED4	
0.2 2012/1/9	17	PBLU / Typ 9.216 , Max 10.886	PBLU / Typ 9.2 , Max 10.9	
0.2 2012/1/9	17		Correct Note 1,2,3,4	
0.2 2012/1/9	28	9.0 Shipping Label / Model No:M215HTN01 V0	9.0 Shipping Label / Model No:M215HTN01.0	
1.0 2012/04/18	2		Add 5.2 Backlight Unit item Add 7.2.2 LED Connector Dimension Add 7.2.3 LED Mating housing dimension Add 11.1 Packing Flow Add 11.2 Pallet and Shipment Information	
1.0 2012/04/18	6	Power Consumption / 14.2(Typ.) (without inverter ; 60 Hz, all black pattern)	Power Consumption(VDD line + LED line) / 13.3W VDD line : PDD (typ), All black pattern at 60Hz = 4.1W LED line : PBLU (typ) = 9.2W	
1.0 2012/04/18	6		Delete TCO Compliance item	
1.0 2012/04/18	9		Add Note 4 Algorithm:   Gray Level A – Gray Level B   $\geq 16$ , then the average gray to gray response time is 2 ms, (F= 60 Hz).	
1.0 2012/04/18	11		Correct Functional Block Diagram	
1.1	11	I/F PCB Interface: FI-XB30SRL-HF11 (JAE)	I/F PCB Interface: FI-XPB30SRLA-HF11 (JAE)	



# Product Specification

M215HTN01.0

AU OPTRONICS CORPORATION

2012/07/20		or 093F30-B0T01A (Starcoon)	01-187121-30091-3(A) (P-TWO)	
1.1 2012/07/20	24	7.1 TFT LCD Module Manufacturer / JAE, Starconn Type Part Number / FI-XB30SRL-HF11(JAE) 093F30-B0T01A(Starconn)	7.1 TFT LCD Module Manufacturer / JAE P-TWO Type Part Number / FI-XPB30SRLA-HF11 01-187121-30091-3(A)	
1.1 2012/07/20	20		Correct Signal Description / Note1	
1.1 2012/07/20	23		Correct Power ON/OFF Sequence	
1.1 2012/07/20	25		Correct 7.2.1 LED Pin assignment / Signal Name Add LED light bar connector illustration	
1.1 2012/07/20	26		Add 7.2.2 LED Connector Dimension Add 7.2.3 LED Mating housing dimension	
1.1 2012/07/20	27	8.0 Reliability Test/Drop Test/ Height: 60 cm, package test	8.0 Reliability Test/Drop Test/ Height: 46 cm, package test	
1.1 2012/07/20	27	ESD (Electro Static Discharge) / Contact Discharge: $\pm 8KV$ , 150pF(330 $\Omega$ ) 1sec, 8 points, 25 times/ point. Air Discharge: $\pm 15KV$ , 150pF(330 $\Omega$ ) 1sec 8 points, 25 times/ point.	ESD (Electro Static Discharge) / Contact Discharge: $\pm 15KV$ , 150pF(330 $\Omega$ ) 1sec, 11 points, 25 times/ point. Air Discharge: $\pm 15KV$ , 150pF(330 $\Omega$ ) 1sec 11 points, 25 times/ point.	
1.1 2012/07/20	27	Altitude Test / Operation:10,000 ft Non-Operation:30,000 ft	Altitude Test /Operation: 18,000 ft Non-Operation: 40,000 ft	
1.1 2012/07/20	29		10.0 Mechanical Characteristics / Add Torqe value & section illustration	
1.2 2012/10/15	11	I/F PCB Interface: FI-XPB30SRLA-HF11 (JAE) 01-187121-30091-3(A) (P-TWO)	I/F PCB Interface: FI-XPB30SRLA-HF11 (JAE) 01-187145-30091-3(A) (P-TWO)	
	24	Type port number : FI-XPB30SRLA-HF11 01-187121-30091-3(A)	Type port number : FI-XPB30SRLA-HF11 01-187145-30091-3(A)	
	6	Power Consumption : 13.3W VDD line : PDD (typ), All black pattern at 60Hz = 4.1W LED line : PBLU (typ) = 9.2W	Power Consumption : <b>13.6W</b> VDD line : PDD (typ), All black pattern at 60Hz = 4.1W LED line : PBLU (typ) = <b>9.5W</b>	



# Product Specification

M215HTN01.0

AU OPTRONICS CORPORATION

17	<p><b>5.2 Backlight Unit-</b> Parameter guideline for LED driving is under stable conditions at 25 °C (Room Temperature):-</p> <table border="1"> <thead> <tr> <th>Symbol</th> <th>Description</th> <th>Min.</th> <th>Typ.</th> <th>Max.</th> <th>Unit</th> <th>Note</th> </tr> </thead> <tbody> <tr> <td>IRLED1~ IRLED2~ IRLED3~ IRLED4~</td> <td>LED Operation Current</td> <td>-</td> <td>60</td> <td>63</td> <td>[mA]</td> <td>Note 1</td> </tr> <tr> <td>VLE</td> <td>Light Bar Operation Voltage (for reference)</td> <td>36</td> <td>38.4</td> <td>43.2</td> <td>[Vdc]</td> <td>Note 2</td> </tr> <tr> <td>PBLU</td> <td>BLU Power Consumption (for reference)</td> <td>-</td> <td>9.2</td> <td>10.9</td> <td>[Watt]</td> <td>Note 3</td> </tr> <tr> <td>LTLED</td> <td>LED Life Time (Typical)</td> <td>30,000</td> <td>-</td> <td>-</td> <td>[Hour]</td> <td>Note 4</td> </tr> </tbody> </table>	Symbol	Description	Min.	Typ.	Max.	Unit	Note	IRLED1~ IRLED2~ IRLED3~ IRLED4~	LED Operation Current	-	60	63	[mA]	Note 1	VLE	Light Bar Operation Voltage (for reference)	36	38.4	43.2	[Vdc]	Note 2	PBLU	BLU Power Consumption (for reference)	-	9.2	10.9	[Watt]	Note 3	LTLED	LED Life Time (Typical)	30,000	-	-	[Hour]	Note 4	<p><b>5.2 Backlight Unit-</b> Parameter guideline for LED driving is under stable conditions at 25 °C (Room Temperature):-</p> <table border="1"> <thead> <tr> <th>Symbol</th> <th>Description</th> <th>Min.</th> <th>Typ.</th> <th>Max.</th> <th>Unit</th> <th>Note</th> </tr> </thead> <tbody> <tr> <td>IRLED1~ IRLED2~ IRLED3~ IRLED4~</td> <td>LED Forward Current</td> <td>-</td> <td>60</td> <td>63</td> <td>[mA]</td> <td>Note 1</td> </tr> <tr> <td>VLE</td> <td>Light Bar Operation Voltage (for reference)</td> <td>34.5</td> <td>39.6</td> <td>43.2</td> <td>[Vdc]</td> <td>Note 2</td> </tr> <tr> <td>PBLU</td> <td>BLU Power Consumption (for reference)</td> <td>8.26</td> <td>9.5</td> <td>10.37</td> <td>[Watt]</td> <td>Note 3</td> </tr> <tr> <td>LTLED</td> <td>LED Life Time (Typical)</td> <td>30,000</td> <td>-</td> <td>-</td> <td>[Hour]</td> <td>Note 4</td> </tr> </tbody> </table>	Symbol	Description	Min.	Typ.	Max.	Unit	Note	IRLED1~ IRLED2~ IRLED3~ IRLED4~	LED Forward Current	-	60	63	[mA]	Note 1	VLE	Light Bar Operation Voltage (for reference)	34.5	39.6	43.2	[Vdc]	Note 2	PBLU	BLU Power Consumption (for reference)	8.26	9.5	10.37	[Watt]	Note 3	LTLED	LED Life Time (Typical)	30,000	-	-	[Hour]	Note 4																																																																			
Symbol	Description	Min.	Typ.	Max.	Unit	Note																																																																																																																																					
IRLED1~ IRLED2~ IRLED3~ IRLED4~	LED Operation Current	-	60	63	[mA]	Note 1																																																																																																																																					
VLE	Light Bar Operation Voltage (for reference)	36	38.4	43.2	[Vdc]	Note 2																																																																																																																																					
PBLU	BLU Power Consumption (for reference)	-	9.2	10.9	[Watt]	Note 3																																																																																																																																					
LTLED	LED Life Time (Typical)	30,000	-	-	[Hour]	Note 4																																																																																																																																					
Symbol	Description	Min.	Typ.	Max.	Unit	Note																																																																																																																																					
IRLED1~ IRLED2~ IRLED3~ IRLED4~	LED Forward Current	-	60	63	[mA]	Note 1																																																																																																																																					
VLE	Light Bar Operation Voltage (for reference)	34.5	39.6	43.2	[Vdc]	Note 2																																																																																																																																					
PBLU	BLU Power Consumption (for reference)	8.26	9.5	10.37	[Watt]	Note 3																																																																																																																																					
LTLED	LED Life Time (Typical)	30,000	-	-	[Hour]	Note 4																																																																																																																																					
25	<p><b>7.2 LED Connector on Backlight Unit-</b> This connector is mounted on LED light bar:-</p> <table border="1"> <thead> <tr> <th>Connector Name / Designation</th> <th>Light Bar Connector</th> </tr> </thead> <tbody> <tr> <td>Manufacturer</td> <td>CVILLIX</td> </tr> <tr> <td>Type/Part Number</td> <td>CII-406111HRB-NH</td> </tr> </tbody> </table>	Connector Name / Designation	Light Bar Connector	Manufacturer	CVILLIX	Type/Part Number	CII-406111HRB-NH	<p><b>7.2 LED Connector on Backlight Unit-</b> This connector is mounted on LED light bar:-</p> <table border="1"> <thead> <tr> <th>Connector Name / Designation</th> <th>Light Bar Connector</th> </tr> </thead> <tbody> <tr> <td>Manufacturer</td> <td>CVILLIX</td> </tr> <tr> <td>Type/Part Number</td> <td>CII-406111HRB-NH</td> </tr> <tr> <td>Mating Housing Part Number</td> <td>-</td> </tr> </tbody> </table>	Connector Name / Designation	Light Bar Connector	Manufacturer	CVILLIX	Type/Part Number	CII-406111HRB-NH	Mating Housing Part Number	-																																																																																																																											
Connector Name / Designation	Light Bar Connector																																																																																																																																										
Manufacturer	CVILLIX																																																																																																																																										
Type/Part Number	CII-406111HRB-NH																																																																																																																																										
Connector Name / Designation	Light Bar Connector																																																																																																																																										
Manufacturer	CVILLIX																																																																																																																																										
Type/Part Number	CII-406111HRB-NH																																																																																																																																										
Mating Housing Part Number	-																																																																																																																																										
21	<p><b>6.4 Timing Characteristics-</b> The input signal timing specifications are shown as the following table:-</p> <table border="1"> <thead> <tr> <th>Signal</th> <th>Item</th> <th>Symbol</th> <th>Min.</th> <th>Typ.</th> <th>Max.</th> <th>Unit</th> </tr> </thead> <tbody> <tr> <td rowspan="3">Vertical Section</td> <td>Period</td> <td>Tp</td> <td>1080</td> <td>1120</td> <td>2047</td> <td>Th</td> </tr> <tr> <td>Active</td> <td>Tdisp(v)</td> <td>1080</td> <td>1080</td> <td>1080</td> <td>Th</td> </tr> <tr> <td>Blanking</td> <td>Tbp(v)+Tfp(v)+FWvs</td> <td>8</td> <td>40</td> <td>967</td> <td>Th</td> </tr> <tr> <td rowspan="3">Horizontal Section</td> <td>Period</td> <td>Th</td> <td>1034</td> <td>1060</td> <td>2047</td> <td>Tclk</td> </tr> <tr> <td>Active</td> <td>Tdisp(h)</td> <td>960</td> <td>960</td> <td>960</td> <td>Tclk</td> </tr> <tr> <td>Blanking</td> <td>Tbp(h)+Tfp(h)+FWhs</td> <td>74</td> <td>100</td> <td>1087</td> <td>Tclk</td> </tr> <tr> <td rowspan="2">Clock</td> <td>Period</td> <td>Tclk</td> <td>25</td> <td>13.3</td> <td>11.1</td> <td>ns</td> </tr> <tr> <td>Frequency</td> <td>Freq</td> <td>40</td> <td>75</td> <td>94</td> <td>MHz</td> </tr> <tr> <td rowspan="2">Frame rate</td> <td>Frame rate</td> <td>F</td> <td>50</td> <td>60</td> <td>75</td> <td>Hz</td> </tr> </tbody> </table>	Signal	Item	Symbol	Min.	Typ.	Max.	Unit	Vertical Section	Period	Tp	1080	1120	2047	Th	Active	Tdisp(v)	1080	1080	1080	Th	Blanking	Tbp(v)+Tfp(v)+FWvs	8	40	967	Th	Horizontal Section	Period	Th	1034	1060	2047	Tclk	Active	Tdisp(h)	960	960	960	Tclk	Blanking	Tbp(h)+Tfp(h)+FWhs	74	100	1087	Tclk	Clock	Period	Tclk	25	13.3	11.1	ns	Frequency	Freq	40	75	94	MHz	Frame rate	Frame rate	F	50	60	75	Hz	<p><b>6.4 Timing Characteristics-</b> The input signal timing specifications are shown as the following table:-</p> <table border="1"> <thead> <tr> <th>Signal</th> <th>Item</th> <th>Symbol</th> <th>Min.</th> <th>Typ.</th> <th>Max.</th> <th>Unit</th> </tr> </thead> <tbody> <tr> <td rowspan="3">Vertical Section</td> <td>Period</td> <td>Tp</td> <td>1092</td> <td>1130</td> <td>1818</td> <td>Th</td> </tr> <tr> <td>Active</td> <td>Tdisp(v)</td> <td>1080</td> <td>1080</td> <td>1080</td> <td>Th</td> </tr> <tr> <td>Blanking</td> <td>Tbp(v)+Tfp(v)+FWvs</td> <td>12</td> <td>60</td> <td>738</td> <td>Th</td> </tr> <tr> <td rowspan="3">Horizontal Section</td> <td>Period</td> <td>Th</td> <td>1034</td> <td>1050</td> <td>1100</td> <td>Tclk</td> </tr> <tr> <td>Active</td> <td>Tdisp(h)</td> <td>900</td> <td>900</td> <td>900</td> <td>Tclk</td> </tr> <tr> <td>Blanking</td> <td>Tbp(h)+Tfp(h)+FWhs</td> <td>74</td> <td>90</td> <td>140</td> <td>Tclk</td> </tr> <tr> <td rowspan="2">Clock</td> <td>Period</td> <td>Tclk</td> <td>10.6</td> <td>14.0</td> <td>17.7</td> <td>ns</td> </tr> <tr> <td>Frequency</td> <td>Freq</td> <td>66.5</td> <td>71.2</td> <td>94.0</td> <td>MHz</td> </tr> <tr> <td rowspan="2">Frame rate</td> <td>Frame rate</td> <td>F</td> <td>60</td> <td>60</td> <td>76</td> <td>Hz</td> </tr> <tr> <td>Frame Frequency</td> <td>Frame Frequency</td> <td>65</td> <td>68</td> <td>81</td> <td>KHz</td> </tr> </tbody> </table>	Signal	Item	Symbol	Min.	Typ.	Max.	Unit	Vertical Section	Period	Tp	1092	1130	1818	Th	Active	Tdisp(v)	1080	1080	1080	Th	Blanking	Tbp(v)+Tfp(v)+FWvs	12	60	738	Th	Horizontal Section	Period	Th	1034	1050	1100	Tclk	Active	Tdisp(h)	900	900	900	Tclk	Blanking	Tbp(h)+Tfp(h)+FWhs	74	90	140	Tclk	Clock	Period	Tclk	10.6	14.0	17.7	ns	Frequency	Freq	66.5	71.2	94.0	MHz	Frame rate	Frame rate	F	60	60	76	Hz	Frame Frequency	Frame Frequency	65	68	81	KHz	
Signal	Item	Symbol	Min.	Typ.	Max.	Unit																																																																																																																																					
Vertical Section	Period	Tp	1080	1120	2047	Th																																																																																																																																					
	Active	Tdisp(v)	1080	1080	1080	Th																																																																																																																																					
	Blanking	Tbp(v)+Tfp(v)+FWvs	8	40	967	Th																																																																																																																																					
Horizontal Section	Period	Th	1034	1060	2047	Tclk																																																																																																																																					
	Active	Tdisp(h)	960	960	960	Tclk																																																																																																																																					
	Blanking	Tbp(h)+Tfp(h)+FWhs	74	100	1087	Tclk																																																																																																																																					
Clock	Period	Tclk	25	13.3	11.1	ns																																																																																																																																					
	Frequency	Freq	40	75	94	MHz																																																																																																																																					
Frame rate	Frame rate	F	50	60	75	Hz																																																																																																																																					
	Signal	Item	Symbol	Min.	Typ.	Max.	Unit																																																																																																																																				
Vertical Section	Period	Tp	1092	1130	1818	Th																																																																																																																																					
	Active	Tdisp(v)	1080	1080	1080	Th																																																																																																																																					
	Blanking	Tbp(v)+Tfp(v)+FWvs	12	60	738	Th																																																																																																																																					
Horizontal Section	Period	Th	1034	1050	1100	Tclk																																																																																																																																					
	Active	Tdisp(h)	900	900	900	Tclk																																																																																																																																					
	Blanking	Tbp(h)+Tfp(h)+FWhs	74	90	140	Tclk																																																																																																																																					
Clock	Period	Tclk	10.6	14.0	17.7	ns																																																																																																																																					
	Frequency	Freq	66.5	71.2	94.0	MHz																																																																																																																																					
Frame rate	Frame rate	F	60	60	76	Hz																																																																																																																																					
	Frame Frequency	Frame Frequency	65	68	81	KHz																																																																																																																																					



## 1 Handling Precautions

- 1) Since front polarizer is easily damaged, pay attention not to scratch it.
- 2) Be sure to turn off power supply when inserting or disconnecting from input connector.
- 3) Wipe off water drop immediately. Long contact with water may cause discoloration or spots.
- 4) When the panel surface is soiled, wipe it with absorbent cotton or other soft cloth.
- 5) Since the panel is made of glass, it may break or crack if dropped or bumped on hard surface.
- 6) Since CMOS LSI is used in this module, take care of static electricity and insure human earth when handling.
- 7) Do not open or modify the Module Assembly.
- 8) Do not press the reflector sheet at the back of the module to any directions.
- 9) In case if a Module has to be put back into the packing container slot after once it was taken out from the container, do not press the center of LED light bar edge. Instead, press at the far ends of the LED light bar edge softly. Otherwise the TFT Module may be damaged.
- 10) At the insertion or removal of the Signal Interface Connector, be sure not to rotate nor tilt the Interface Connector of the TFT Module.
- 11) After installation of the TFT Module into an enclosure, do not twist nor bend the TFT Module even momentary. At designing the enclosure, it should be taken into consideration that no bending/twisting forces are applied to the TFT Module from outside. Otherwise the TFT Module may be damaged.
- 12) Small amount of materials having no flammability grade is used in the LCD module. The LCD module should be supplied by power complied with requirements of Limited Power Source (IEC60950 or UL1950), or be applied exemption.
- 13) Avoid touching COF position while doing mechanical design.
- 14) While storing modules as spares for a long time, the following precautions are necessary:
  - Store modules in a dark place. Do not expose them to sunlight or fluorescent light.
  - Keep the temperature between 5°C and 35°C at normal humidity.
- 15) Pls avoid touching COF position while you are doing mechanical design.
- 16) When storing modules as spares for a long time, the following precaution is necessary: Store them in a dark place. Do not expose the module to sunlight or fluorescent light. Keep the temperature between 5°C and 35°C at normal humidity.



# Product Specification

M215HTN01.0

AU OPTRONICS CORPORATION

## 2 General Description

This specification applies to the 21.5 inch-FHD color  $\alpha$ -Si TFT-LCD Module M215HTN01.0. The display supports the FHD - 1920(H) x 1080(V) screen format and 16.7M colors (RGB 6-bit data). The light source of this TFT-LCD module is W-LED. All input signals are 2-channel LVDS interface and this module doesn't contain a driver for backlight.

### 2.1 Display Characteristics

The following items are characteristics summary on the table under 25°C condition:

Items	Unit	Specification
Screen Diagonal	[mm]	546.86 (21.53")
Active Area	[mm]	476.64 (H) x 268.11 (V)
Pixels H x V		1920(x3) x 1080
Pixel Pitch	[ $\mu$ m]	248.25 (per one triad) $\times$ 248.25
Pixel Arrangement		R.G.B. Vertical Stripe
Display Mode		TN Mode, Normally White
White Luminance ( Center )	[cd/m <sup>2</sup> ]	200 cd/m <sup>2</sup> (Typ.)
Contrast Ratio		600 (Typ.)
Optical Response Time	[msec]	5ms (Typ., on/off)
Nominal Input Voltage VDD	[Volt]	+5.0 V (Type)
Power Consumption (VDD line + LED line)	[Watt]	13.6W VDD line : PDD (typ), All black pattern at 60Hz = 4.1W LED line : PBLU (typ) = 9.5W
Weight	[Grams]	1850 (Typ.)
Physical Size	[mm]	495.6(H) $\times$ 292.2(V) $\times$ 10.3(D)
Electrical Interface		Dual channel LVDS
Support Color		16.7M colors (RGB 6-bit + Hi_FRC )
Surface Treatment		Anti-Glare, 3H
Temperature Range		
Operating	[°C]	0 to +50
Storage (Shipping)	[°C]	-20 to +60
RoHS Compliance		RoHS Compliance



# Product Specification

M215HTN01.0

AU OPTRONICS CORPORATION

## 2.2 Optical Characteristics

The optical characteristics are measured under stable conditions at 25°C:

Item	Unit	Conditions	Min.	Typ.	Max.	Note
Viewing Angle	[degree]	Horizontal (Right)	40	45	-	<b>2</b>
		CR = 10 (Left)	40	45	-	
		Vertical (Up)	15	20	-	
		CR = 10 (Down)	40	45	-	
Contrast ratio		Normal Direction	360	600	-	<b>3</b>
Response Time	[msec]	Raising Time (Tr <sub>R</sub> )	-	3.8	5.5	<b>4</b>
		Falling Time (Tr <sub>F</sub> )	-	1.2	2.5	
		Raising + Falling	-	5	8	
		Gray to Gray(16x16 avg.)				
Color / Chromaticity Coordinates (CIE)		Red x	0.610	0.640	0.670	<b>5</b>
		Red y	0.300	0.330	0.360	
		Green x	0.302	0.332	0.362	
		Green y	0.595	0.625	0.655	
		Blue x	0.126	0.156	0.186	
		Blue y	0.019	0.049	0.079	
Color Coordinates (CIE) White		White x	0.283	0.313	0.343	<b>5</b>
		White y	0.299	0.329	0.359	
Central Luminance	[cd/m <sup>2</sup> ]		160	200	-	<b>6</b>
Luminance Uniformity	[%]		75	80	-	<b>7</b>
Crosstalk (in 60Hz)	[%]				1.5	<b>8</b>
Flicker	dB				-20	<b>9</b>





# Product Specification

M215HTN01.0

AU OPTRONICS CORPORATION

## Note 1: Measurement Method

The LCD module should be stabilized at given temperature for 30 minutes to avoid abrupt temperature change during measuring (at surface 35°C). In order to stabilize the luminance, the measurement should be executed after lighting Backlight for 30 minutes in a stable, windless and dark room.

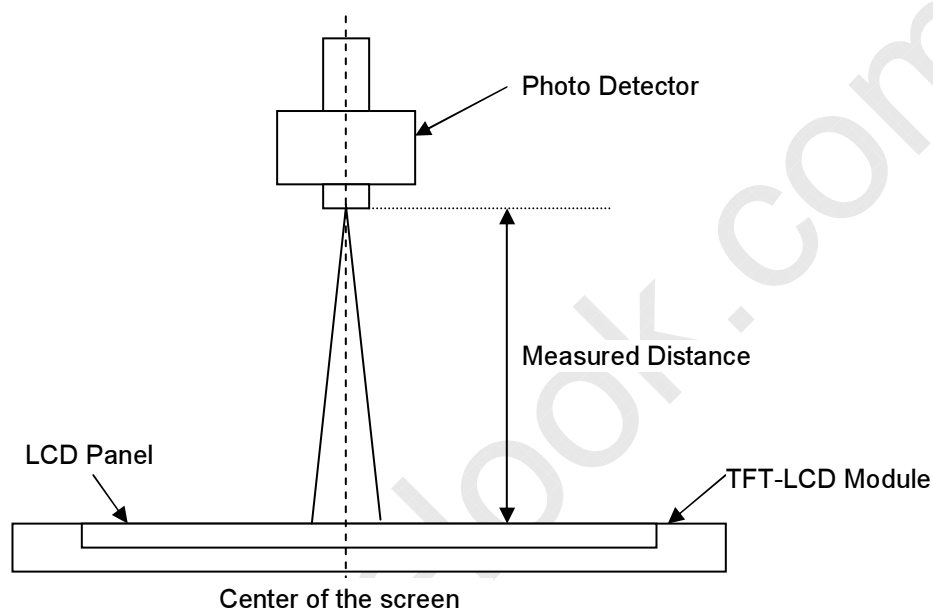

## Note 2: Definition of Viewing Angle measured by ELDIM (EZContrast 88)

Viewing angle is the measurement of contrast ratio  $\geq 10$ , at the screen center, over a 180° horizontal and 180° vertical range (off-normal viewing angles). The 180° viewing angle range is broken down as follows; 90° ( $\theta$ ) horizontal left and right and 90° ( $\Phi$ ) vertical, high (up) and low (down). The measurement direction is typically perpendicular to the display surface with the screen rotated about its center to develop the desired measurement viewing angle.

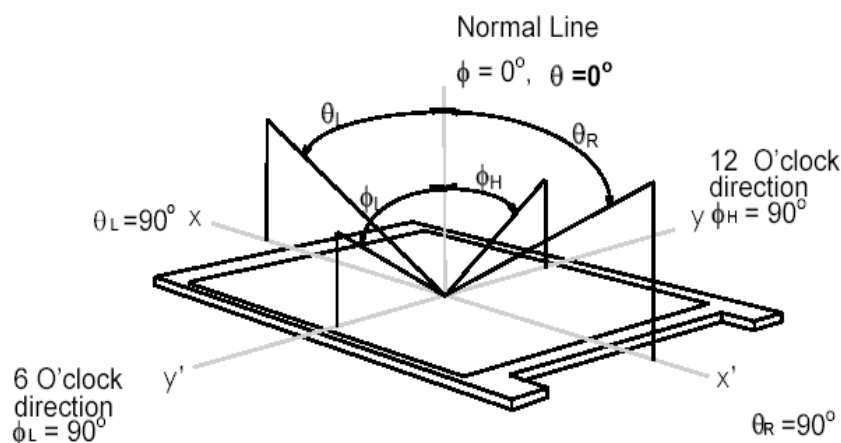



# Product Specification

M215HTN01.0

AU OPTRONICS CORPORATION

**Note 3: Contrast Ratio** measured by TOPCON SR-3

**Note 4: Definition of Response time** measured by Westar TRD-100A

The output signals of photo detector are measured when the input signals are changed from "Full Black" to "Full White" (rising time,  $T_{rR}$ ), and from "Full White" to "Full Black" (falling time,  $T_{rF}$ ), respectively. The response time is interval between the 10% and 90% (1 frame at 60 Hz) of amplitudes.

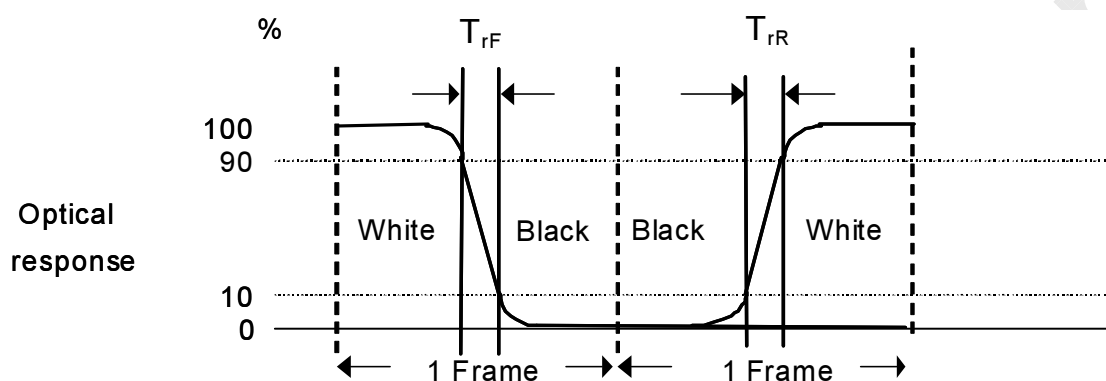

$T_{rR} + T_{rF} = 5 \text{ msec (typ.)}$ .

Algorithm:  $|\text{Gray Level A} - \text{Gray Level B}| \geq 16$ , then the average gray to gray response time is 2 ms, (F= 60 Hz).

**Note 5: Color Chromaticity and Coordinates (CIE)** measured by TOPCON SR-3

**Note 6: Central Luminance** measured by TOPCON SR-3

**Note 7: Luminance Uniformity** of these 9 points defined as below and measured by TOPCON SR-3

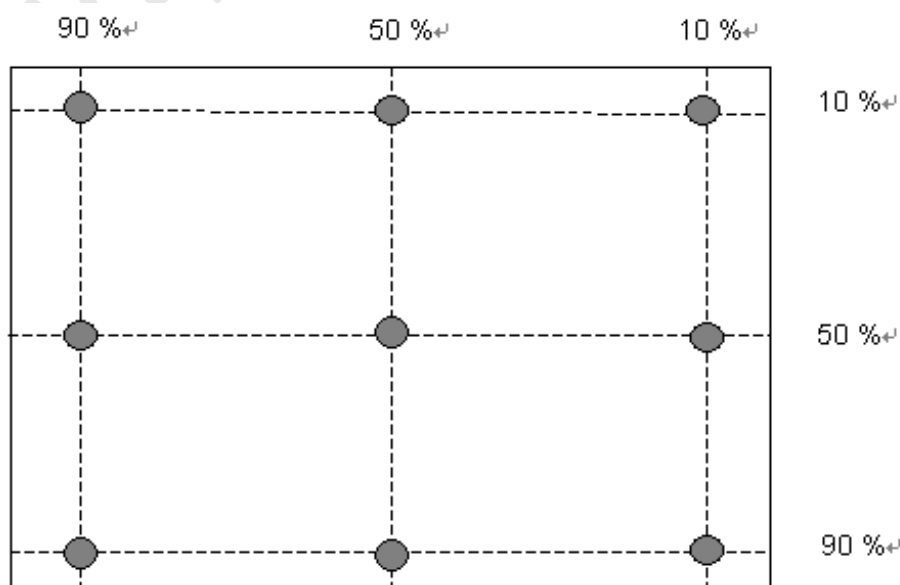



# Product Specification

M215HTN01.0

AU OPTRONICS CORPORATION

$$\text{Uniformity} = \frac{\text{Minimum Luminance in 9 points (1-9)}}{\text{Maximum Luminance in 9 Points (1-9)}}$$

**Note 8: Crosstalk** defined as below and measured by TOPCON SR-3

$$CT = | YB - YA | / YA \times 100 (\%)$$

Where

YA = Luminance of measured location without gray level 0 pattern (cd/m2)

YB = Luminance of measured location with gray level 0 pattern (cd/m2)

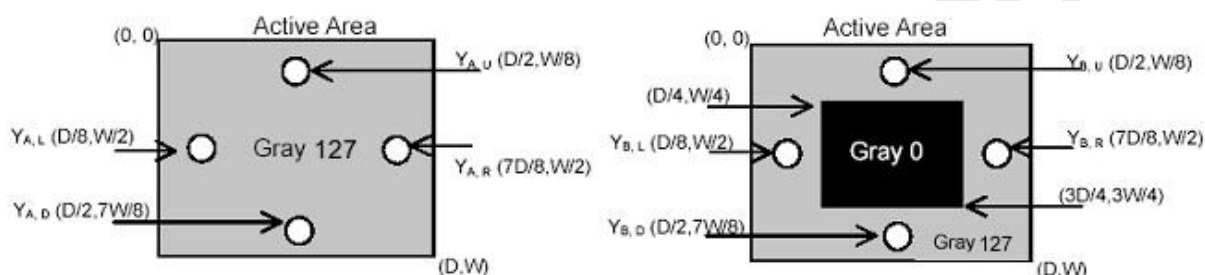

**Note 9: Test Pattern Sub-checker Pattern** measured by TOPCON SR-3

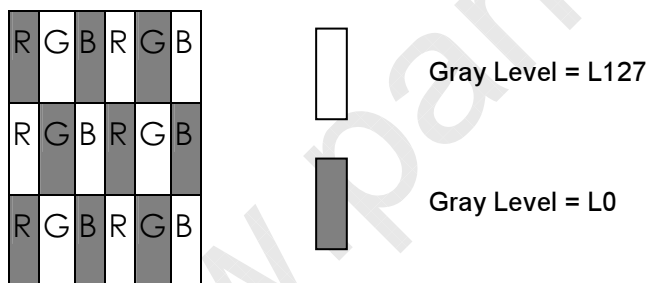

Method: Record dBV & DC value with TRD-100

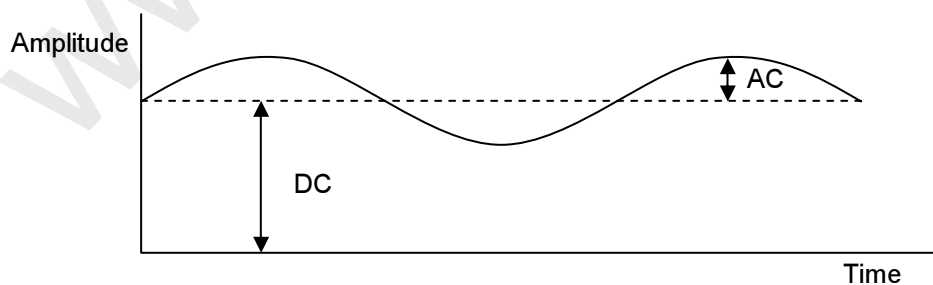

$$\text{Flicker (dB)} = 20 \log \frac{\text{AC Level(at 30 Hz)}}{\text{DC Level}}$$



# Product Specification

M215HTN01.0

AU OPTRONICS CORPORATION

## 3 Functional Block Diagram

The following diagram shows the functional block of the 21.5 inch Color TFT-LCD Module:

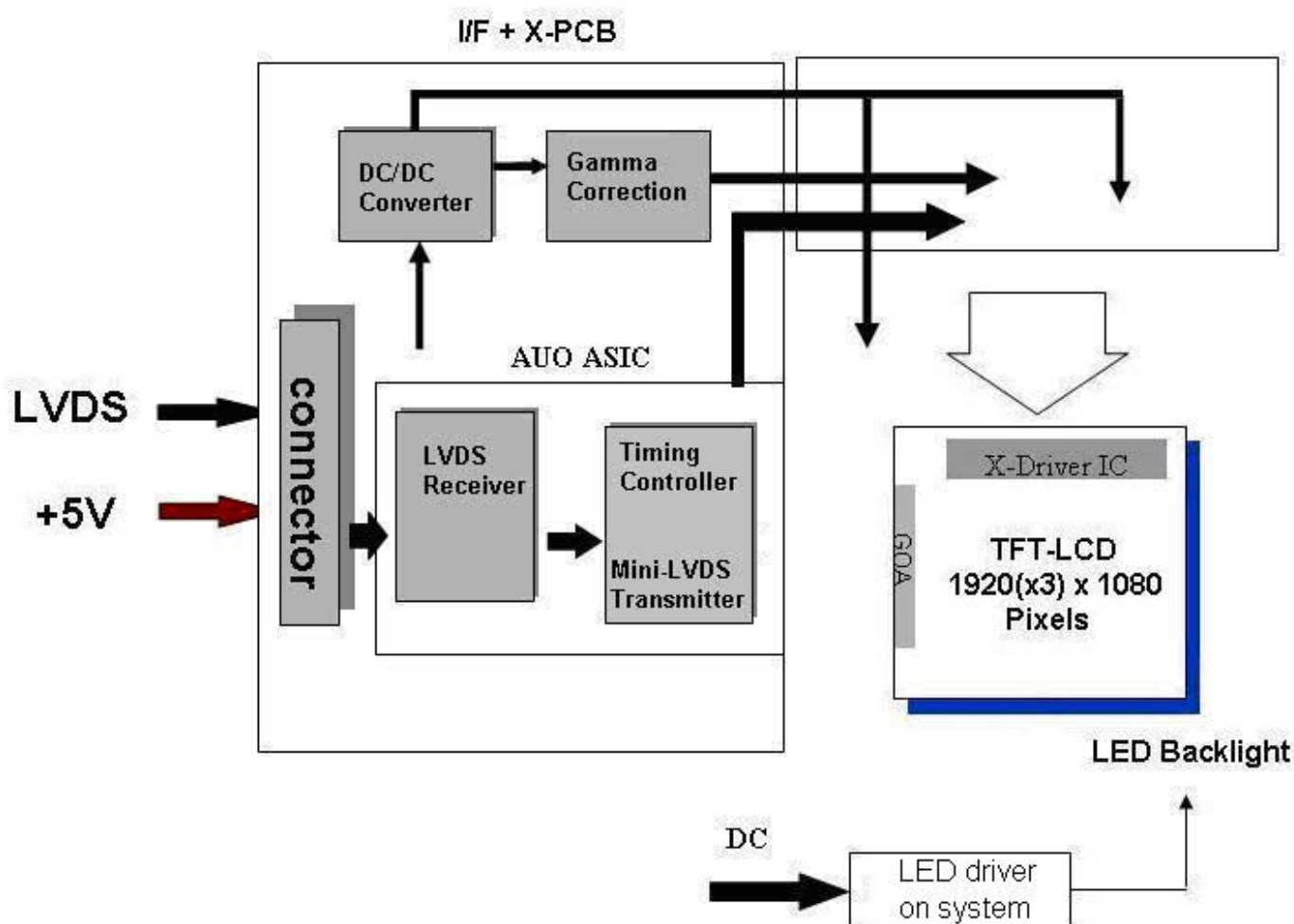

### I/F PCB Interface:

FI-XPB30SRLA-HF11 (JAE)

01-187145-30091-3(A) (P-TWO)

### Mating Type:

FI-X30HL (Locked Type)



# Product Specification

M215HTN01.0

AU OPTRONICS CORPORATION

## 4 Absolute Maximum Ratings

Absolute maximum ratings of the module are listed as follows:

### 4.1 TFT LCD Module

Item	Symbol	Min	Max	Unit	Conditions
Logic/LCD Drive	VDD	0	6	[Volt]	<b>Note 1,2</b>

### 4.2 Backlight Unit

Item	Symbol	Min	Max	Unit	Conditions
LED Forward Current	IRLED1	0	90	[mA]	<b>Note 1,2,5</b> 100% duty
	IRLED2				
	IRLED3				
	IRLED4				
LED Pulse Forward Current	IPLD1	-	150	[mA]	<b>Note 1,2,5</b> 10% duty @100Hz
	IPLD2				
	IPLD3				
	IPLD4				
LED forward Voltage variation (per string variation)	$\Delta V_f$	3.0	3.6	[Volt]	<b>Note 1,2</b>

### 4.3 Absolute Ratings of Environment

Item	Symbol	Min.	Max.	Unit	Conditions
Operating Temperature	TOP	0	+50	[°C]	<b>Note 3</b>
Glass surface temperature (operation)	TGS	0	+65	[°C]	<b>Note3</b> <b>Note4</b>
Operation Humidity	HOP	5	90	[%RH]	<b>Note 3</b>
Storage Temperature	TST	-20	+60	[°C]	
Storage Humidity	HST	5	90	[%RH]	

**Note 1:** With in Ta (25°C)

**Note 2:** Permanent damage to the device may occur if exceeding maximum values

**Note 3:** Temperature and relative humidity range are shown as the below figure.

1. 90% RH Max ( Ta ≤ 39°C)
2. Max wet-bulb temperature at 39°C or less. ( Ta ≤ 39°C)
3. No condensation

**Note 4:** Function Judged only

**Note 5:** IRLED1,2,3,4 and IPLD1,2,3,4 define as per strings LED current.



# Product Specification

M215HTN01.0

AU OPTRONICS CORPORATION

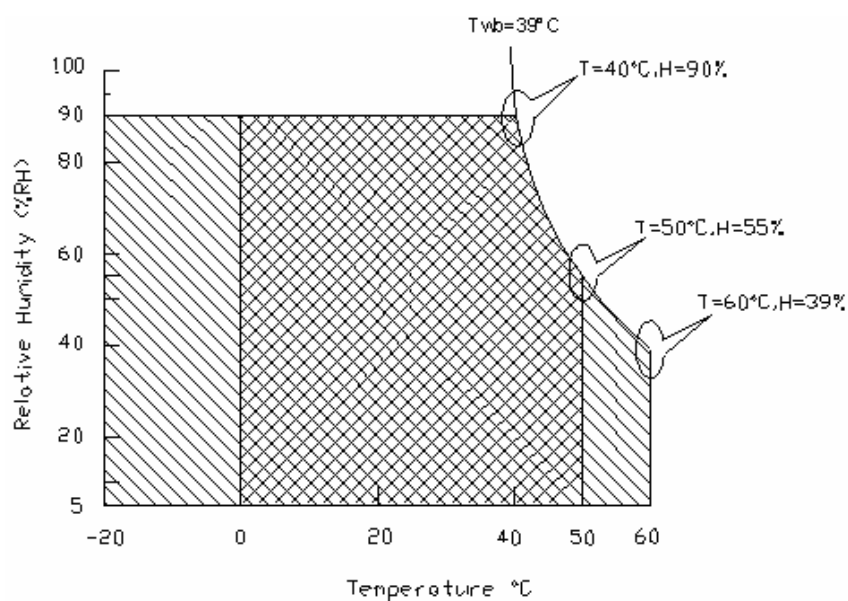

Operating Range



Storage Range

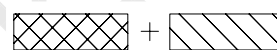





# Product Specification

M215HTN01.0

AU OPTRONICS CORPORATION

## 5.1.2 Signal Electrical Characteristics

(1) DC Characteristics of each signal are as following:

Symbol	Description	Min	Typ	Max	Units	Conditions
$V_{TH}$	Differential Input High Threshold	-	-	+100	[mV]	$V_{CM} = 1.2V$ <b>Note 1</b>
$V_{TL}$	Differential Input Low Threshold	-100	-	-	[mV]	$V_{CM} = 1.2V$ <b>Note 1</b>
$ V_{ID} $	Input Differential Voltage	100	-	600	[mV]	<b>Note 1</b>
$V_{CM}$	Differential Input Common Mode Voltage	+1.0	+1.2	+1.5	[V]	$V_{TH}-V_{TL} = 200mV$ (max) <b>Note 1</b>

**Note 1:** LVDS Signal Waveform

### Single-End

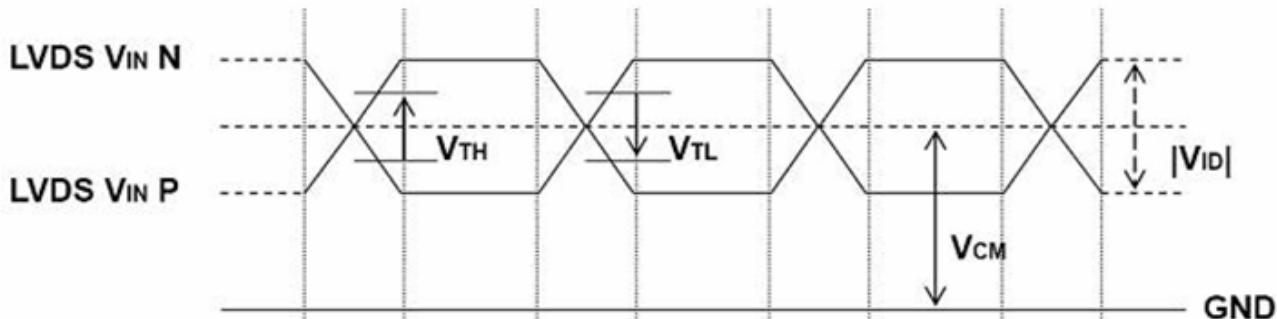

### Differential Signal

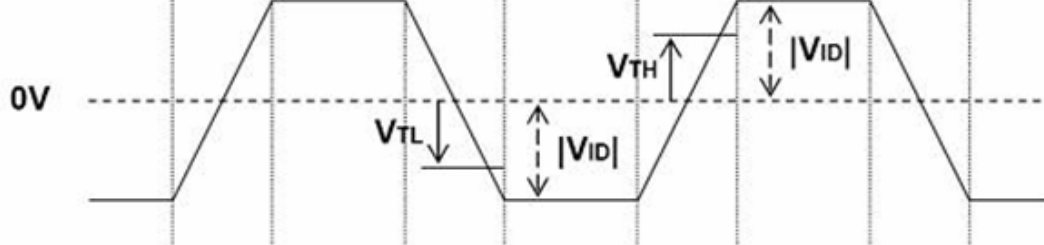





# Product Specification

M215HTN01.0

AU OPTRONICS CORPORATION

## (2) AC Characteristics

Symbol	Description	Min	Max	Units	Conditions
$F_{DEV}$	Maximum deviation of input clock frequency during SSC	-	$\pm 3$	%	
$F_{MOD}$	Maximum modulation frequency of input clock during SSC	-	200	KHz	

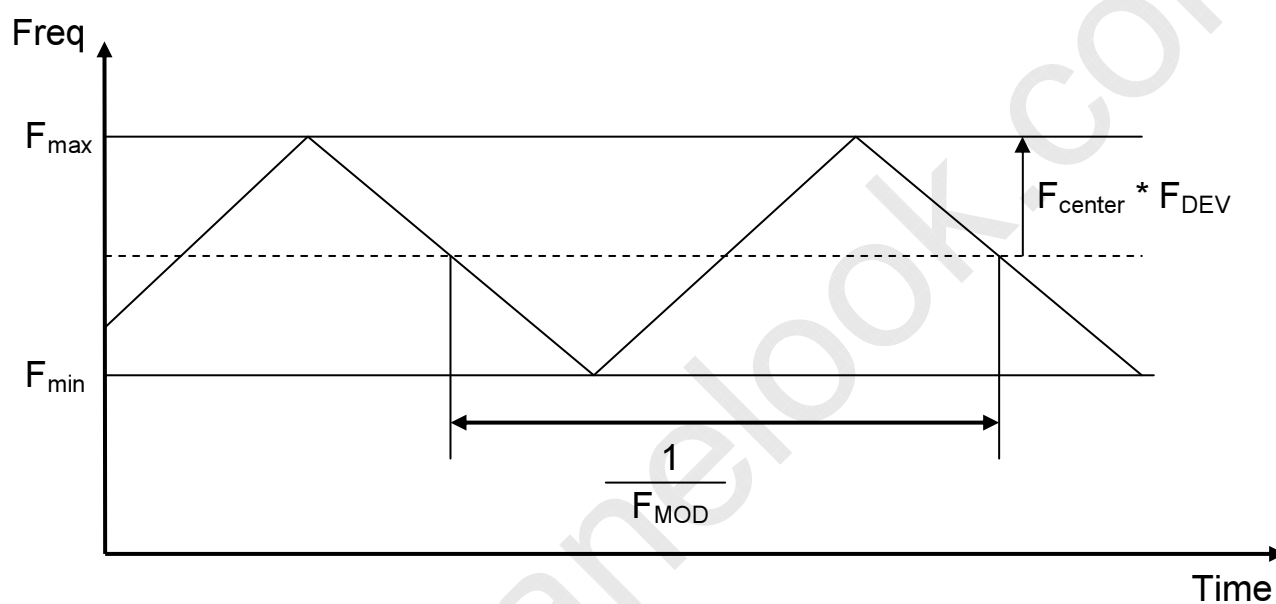

< Spread Spectrum >



# Product Specification

M215HTN01.0

AU OPTRONICS CORPORATION

## 5.2 Backlight Unit

Parameter guideline for LED driving is under stable conditions at 25 °C (Room Temperature):

Symbol	Description	Min.□	Typ.	Max.	Unit	Note
IRLED1	LED Forward Current	-	60	63	[mA]	<b>Note 1</b>
IRLED2						
IRLED3						
IRLED4						
VLED	Light Bar Operation Voltage (for reference)	34.5	39.6	43.2	[Volt]	<b>Note 2</b>
PBLU	BLU Power Consumption (for reference)	8.28	9.5	10.37	[Watt]	<b>Note 3</b>
LTLED	LED Life Time (Typical)	30,000	-	-	[Hour]	<b>Note 4</b>

Each module consists of 48 pcs LED ( 4 strings x 12 pcs / string )

**Note 1:** The specified current is 100% duty of LED chip input current, IRLED1,2,3,4 define as per strings LED current.

**Note 2:** The value showed is one string operation voltage.

**Note 3:**  $PBLU = VLED * (IRLED1 + IRLED2 + IRLED3 + IRLED4)$

**Note 4:** Definition of life time: Brightness becomes to 50% of its original value. The minimum life time of LED unit is on the condition of IRLED = 60mA and 25±2°C (Room Temperature).



# Product Specification

M215HTN01.0

AU OPTRONICS CORPORATION

## 6 Signal Characteristics

### 6.1 Pixel Format Definition

Following figure shows the relationship between the input signals and LCD pixel format.

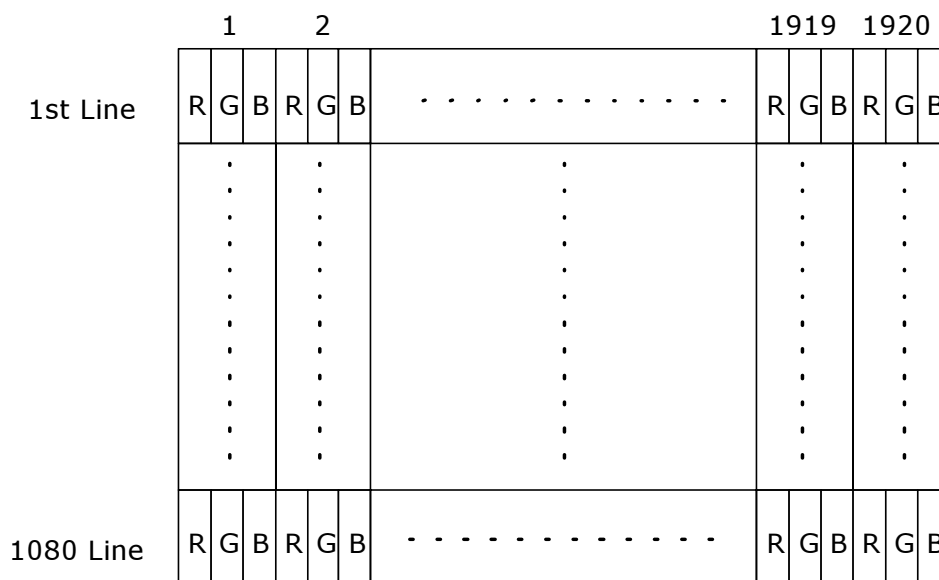

### 6.2 Input Data Format Definition

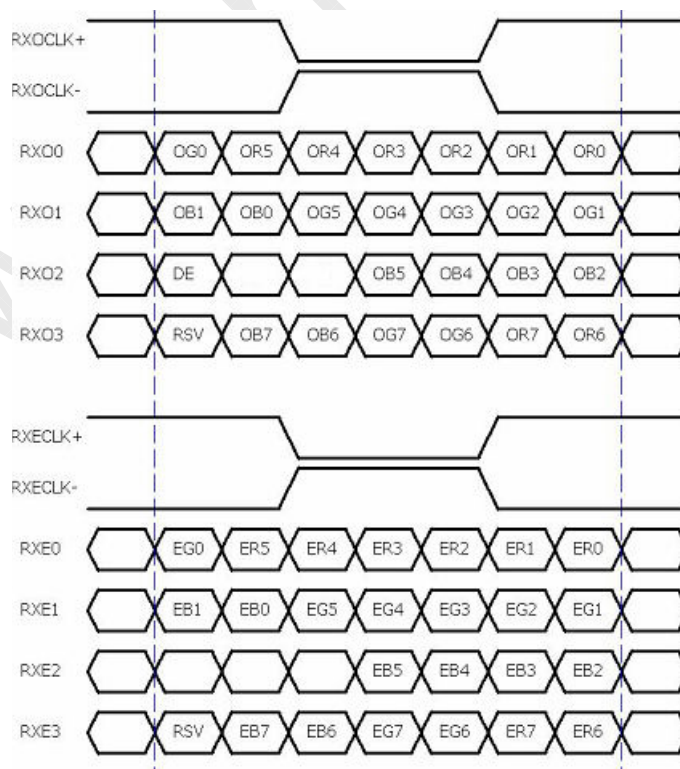

**Note 1:** R/G/B data 7:MSB, R/G/B data 0:LSB    O = "Odd Pixel Data"    E = "Even Pixel Data"



# Product Specification

M215HTN01.0

AU OPTRONICS CORPORATION

## 6.3 Signal Description

PIN #	SIGNAL NAME	DESCRIPTION
1	RxOIN0-	Negative LVDS differential data input (Odd data)
2	RxOIN0+	Positive LVDS differential data input (Odd data)
3	RxOIN1-	Negative LVDS differential data input (Odd data)
4	RxOIN1+	Positive LVDS differential data input (Odd data)
5	RxOIN2-	Negative LVDS differential data input (Odd data, DSPTMG)
6	RxOIN2+	Positive LVDS differential data input (Odd data, DSPTMG)
7	GND	Power Ground
8	RxOCLK-	Negative LVDS differential clock input (Odd clock)
9	RxOCLK+	Positive LVDS differential clock input (Odd clock)
10	RxOIN3-	Negative LVDS differential data input (Odd data)
11	RxOIN3+	Positive LVDS differential data input (Odd data)
12	RxEIN0-	Negative LVDS differential data input (Even data)
13	RxEIN0+	LVDS differential data input (Even data)
14	GND	Power Ground
15	RxEIN1-	Negative LVDS differential data input (Even data)
16	RxEIN1+	Positive LVDS differential data input (Even data)
17	GND	Power Ground
18	RxEIN2-	Negative LVDS differential data input (Even data)
19	RxEIN2+	Positive LVDS differential data input (Even data)
20	RxECLK-	Negative LVDS differential clock input (Even clock)
21	RxECLK+	Positive LVDS differential clock input (Even clock)
22	RxEIN3-	Negative LVDS differential data input (Even data)
23	RxEIN3+	Positive LVDS differential data input (Even data)
24	GND	Power Ground
25	NC	No connection (for AUO test only. Do not connect)
26	NC	No connection (for AUO test only. Do not connect)
27	NC	No connection (for AUO test only. Do not connect)
28	VDD	Power +5V
29	VDD	Power +5V
30	VDD	Power +5V

**Note 1:** Input signals of odd and even clock shall be the same timing.



# Product Specification

M215HTN01.0

AU OPTRONICS CORPORATION

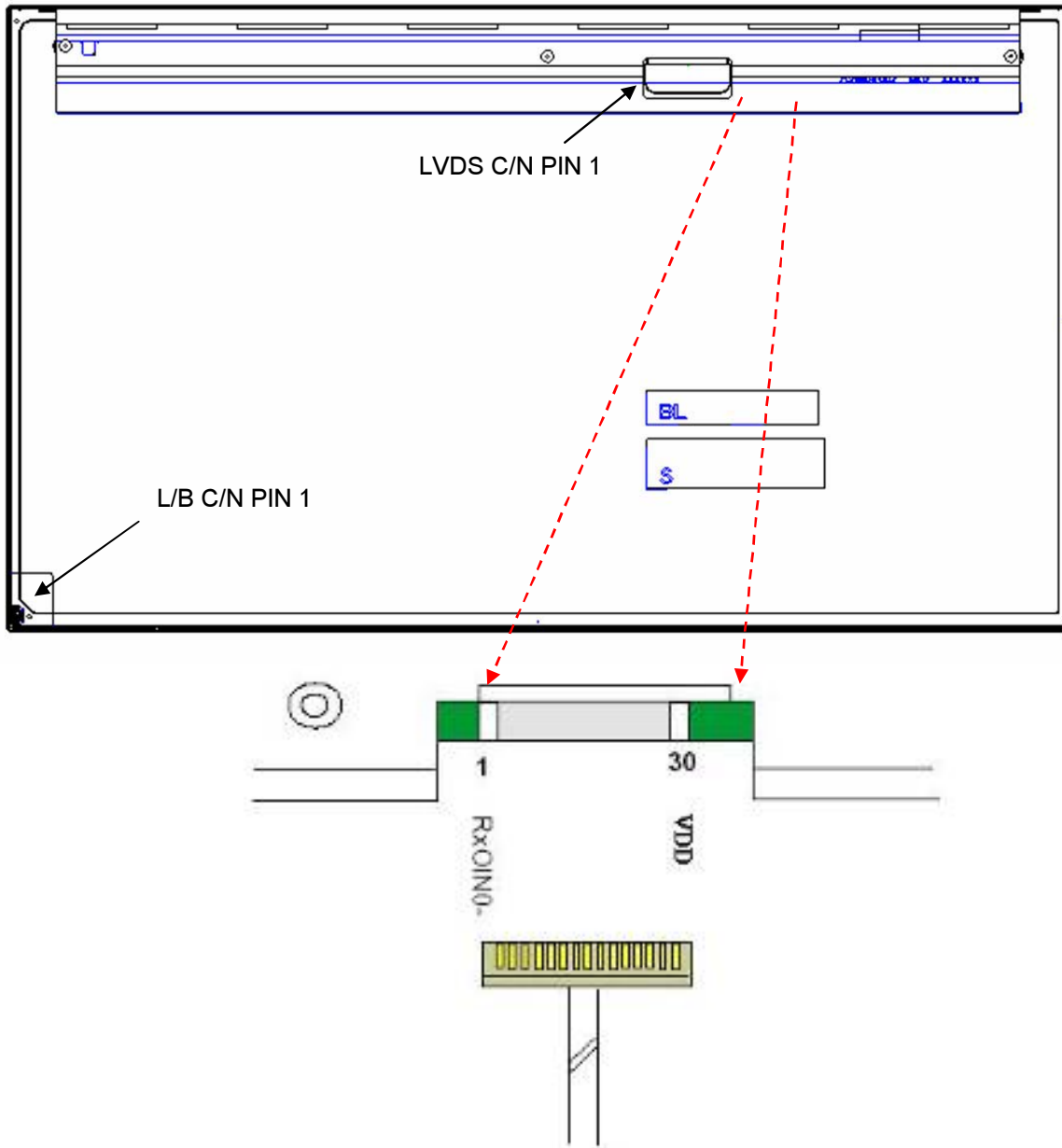



# Product Specification

M215HTN01.0

AU OPTRONICS CORPORATION

## 6.4 Timing Characteristics

The input signal timing specifications are shown as the following table

Signal	Item	Symbol	Min	Typ	Max	Unit
Vertical Section	Period	Tv	1092	1130	1818	Th
	Active	Tdisp(v)	1080	1080	1080	Th
	Blanking	Tbp(v)+Tfp(v)+PWvs	12	50	738	Th
Horizontal Section	Period	Th	1034	1050	1100	Tclk
	Active	Tdisp(h)	960	960	960	Tclk
	Blanking	Tbp(h)+Tfp(h)+PWhs	74	90	140	Tclk
Clock	Period	Tclk	10.6	14.0	17.7	ns
	Frequency	Freq	56.5	71.2	94.0	MHz
Frame rate	Frame rate	F	50	60	76	Hz
Hsync Frequency	Hsync Frequency	HFreq	55	68	91	KHz

**Note 1:** DE mode only



# Product Specification

M215HTN01.0

AU OPTRONICS CORPORATION

## 6.5 Timing Diagram

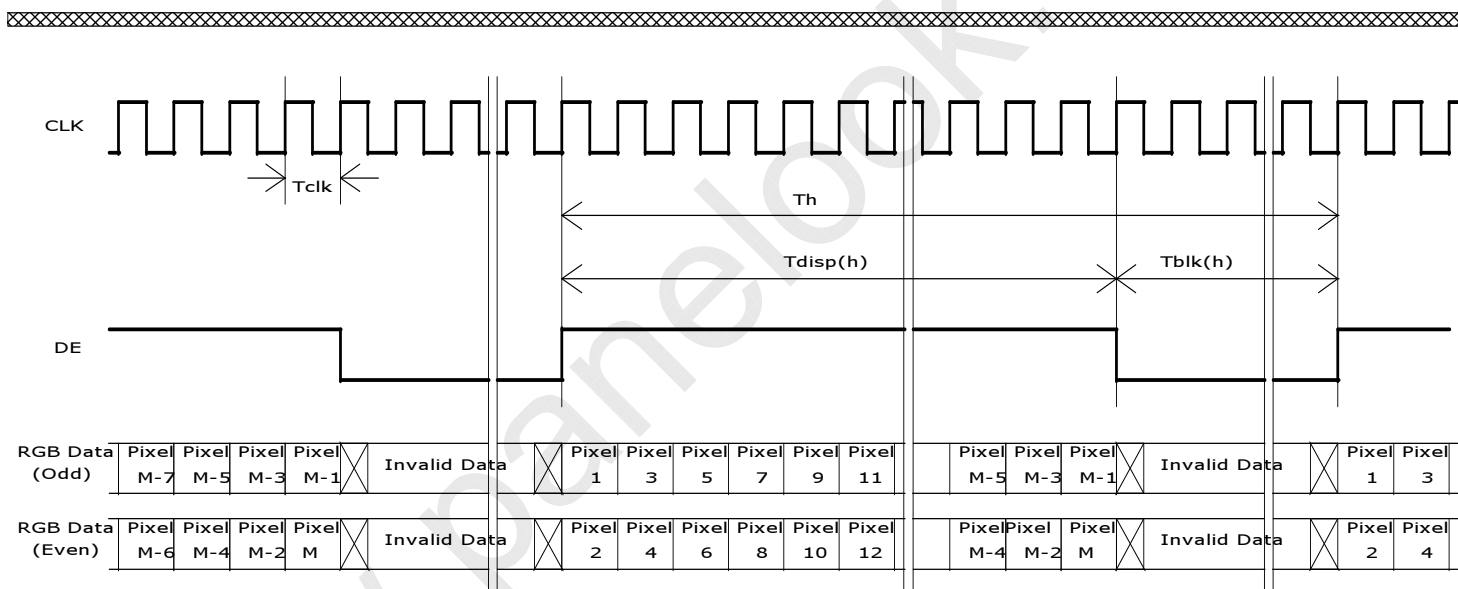
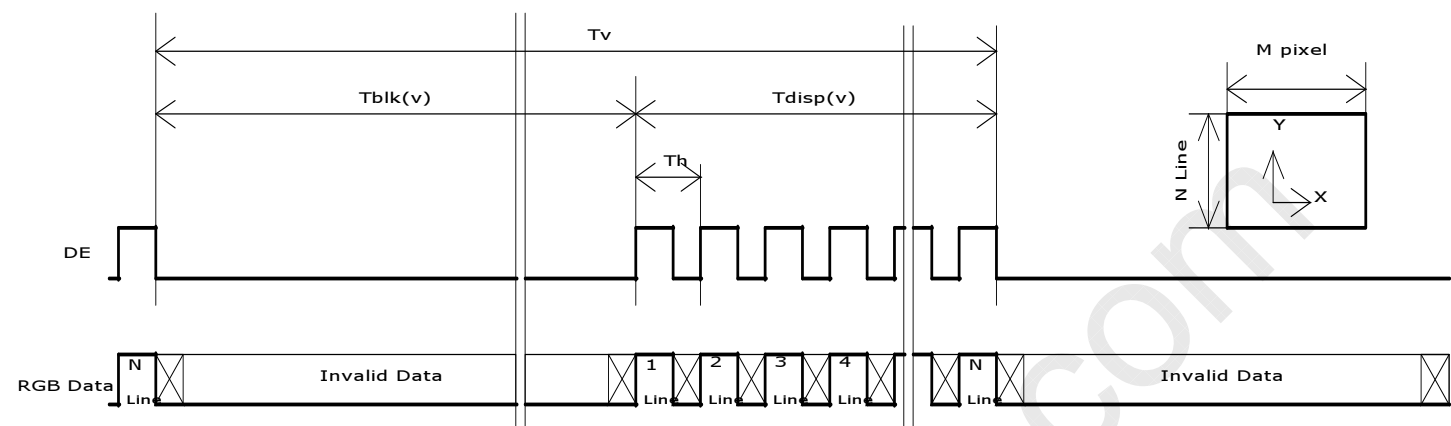



# Product Specification

M215HTN01.0

AU OPTRONICS CORPORATION

## 6.6 Power ON/OFF Sequence

VDD power and lamp on/off sequence are as follows. Interface signals are also shown in the chart. Signals from any system shall be Hi-Z state when VDD is off.

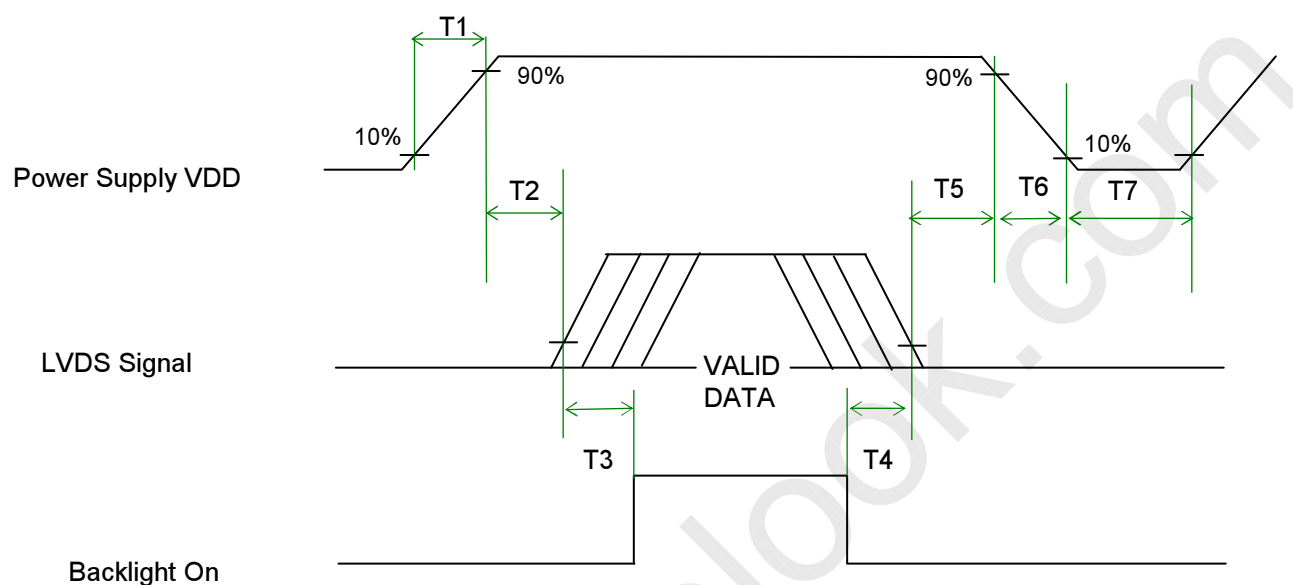

Power Sequence Timing

Parameter	Value			Unit
	Min.	Typ.	Max.	
T1	0.5	-	10	[ms]
T2	0	-	50	[ms]
T3	500	-	-	[ms]
T4	100	-	-	[ms]
T5	0	-	50	[ms] Note 1,2
T6	5	-	100	[ms] Note 1,2
T7	1000	-	-	[ms]

**Note 1 :** Recommend setting T5 = 0ms to avoid electronic noise when VDD is off.

**Note 2 :** During T5 and T6 period , please keep the level of input LVDS signals with Hi-Z state.





# Product Specification

M215HTN01.0

AU OPTRONICS CORPORATION

## 7 Connector and Pin Assignment

Physical interface is described as for the connector on module. These connectors are capable of accommodating the following signals and will be following components.

### 7.1 TFT LCD Module

Connector Name / Designation	Interface Connector / Interface Card
Manufacturer	JAE P-TWO
Type Part Number	FI-XPB30SRLA-HF11 01-187145-30091-3(A)
Mating Housing Part Number	FI-X30HL (Locked Type)

#### 7.1.1 Pin Assignment

Pin#	Signal Name	Pin#	Signal Name
1	RxOIN0-	2	RxOIN0+
3	RxOIN1-	4	RxOIN1+
5	RxOIN2-	6	RxOIN2+
7	GND	8	RxOCLKIN-
9	RxOCLKIN+	10	RxOIN3-
11	RxOIN3+	12	RxEIN0-
13	RxEIN0+	14	GND
15	RxEIN1-	16	RxEIN1+
17	GND	18	RxEIN2-
19	RxEIN2+	20	RxECLKIN-
21	RxECLKIN+	22	RxEIN3-
23	RxEIN3+	24	GND
25	NC (for AUO test only. Do not connect)	26	NC (for AUO test only. Do not connect)
27	NC (for AUO test only. Do not connect)	28	VDD
29	VDD	30	VDD



# Product Specification

M215HTN01.0

AU OPTRONICS CORPORATION

## 7.2 LED Connector on Backlight Unit

This connector is mounted on LED light bar.

Connector Name / Designation	Light Bar Connector
Manufacturer	CVILUX
Type Part Number	CI1406M1HRB-NH
Mating Housing Part Number	

### 7.2.1 LED Pin assignment

Pin#	Signal Name
1	IRLED1 (current out)
2	IRLED2 (current out)
3	VLED (voltage in)
4	VLED (voltage in)
5	IRLED3 (current out)
6	IRLED4 (current out)

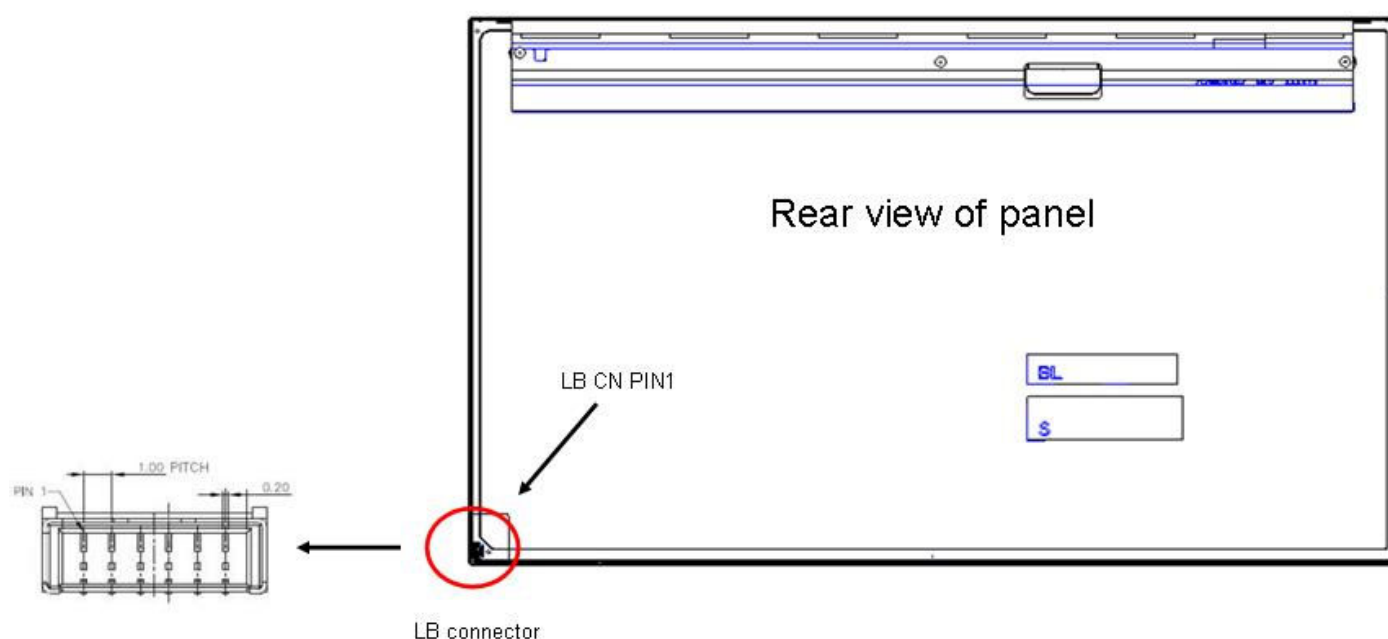



## Product Specification

M215HTN01.0

AU OPTRONICS CORPORATION

### 7.2.2 LED Connector Dimension

$H \times V \times D = 7.9 \times 3.05 \times 4.25$ , Pitch = 1.0 (unit = mm)

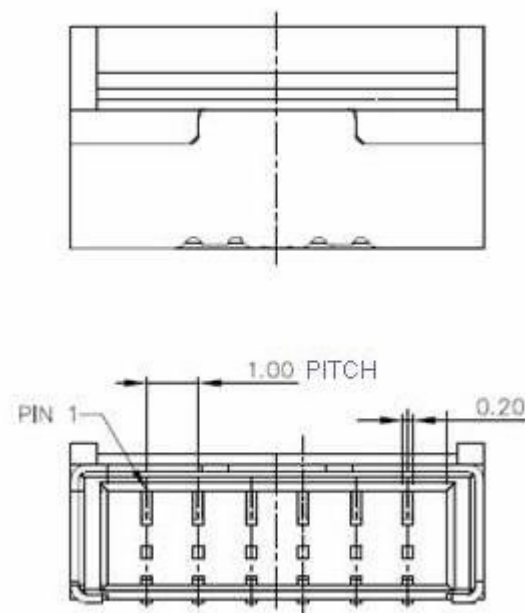

### 7.2.3 LED Mating housing dimension

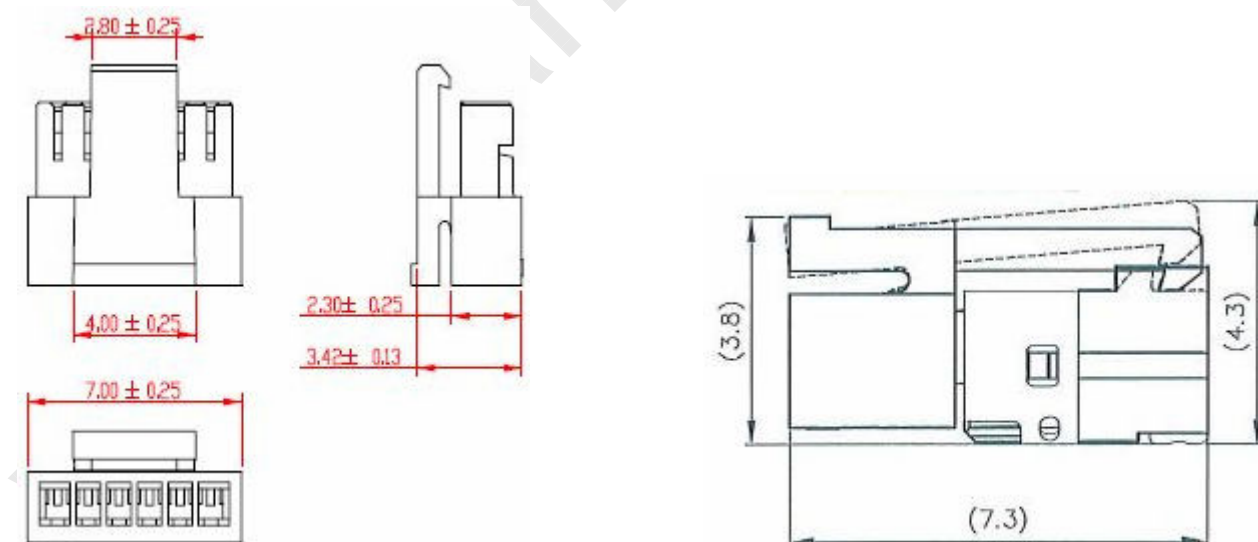



# Product Specification

M215HTN01.0

AU OPTRONICS CORPORATION

## 8 Reliability Test

Environment test conditions are listed as following table.

Items	Required Condition	Note
Temperature Humidity Bias (THB)	Ta= 50°C, 80%RH, 300 hours	
High Temperature Operation (HTO)	Ta= 50°C, 50%RH, 300 hours	
Low Temperature Operation (LTO)	Ta= 0°C, 300 hours	
High Temperature Storage (HTS)	Ta= 60°C, 300 hours	
Low Temperature Storage (LTS)	Ta= -20°C, 300 hours	
Vibration Test (Non-operation)	Acceleration: 1.5 Grms Wave: Random Frequency: 10 - 200 Hz Duration: 30 Minutes each Axis (X, Y, Z)	
Shock Test (Non-operation)	Acceleration: 50 G Wave: Half-sine Active Time: 20 ms Direction: ±X, ±Y, ±Z (one time for each Axis)	
Drop Test	Height: 46 cm, package test	
Thermal Shock Test (TST)	-20°C/30min, 60°C/30min, 100 cycles	<b>Note 1</b>
On/Off Test	On/10sec, Off/10sec, 30,000 cycles	
ESD (Electro Static Discharge)	Contact Discharge: ± 15KV, 150pF(330Ω ) 1sec, 11 points, 25 times/ point.	<b>Note 2</b>
	Air Discharge: ± 15KV, 150pF(330Ω ) 1sec 11 points, 25 times/ point.	
Altitude Test	Operation: 18,000 ft Non-Operation: 40,000 ft	

**Note 1:** The TFT-LCD module will not sustain damage after being subjected to 100 cycles of rapid temperature change. A cycle of rapid temperature change consists of varying the temperature from -20°C to 60°C, and back again. Power is not applied during the test. After temperature cycling, the unit is placed in normal room ambient for at least 4 hours before power on.

**Note 2:** EN61000-4-2, ESD class B: Certain performance degradation allowed:

- No data lost
- Self-recoverable
- No hardware failures



# Product Specification

M215HTN01.0

AU OPTRONICS CORPORATION

www.panelook.com



## Product Specification

M215HTN01.0

AU OPTRONICS CORPORATION

### 9 Shipping Label

The label is on the panel as shown below:

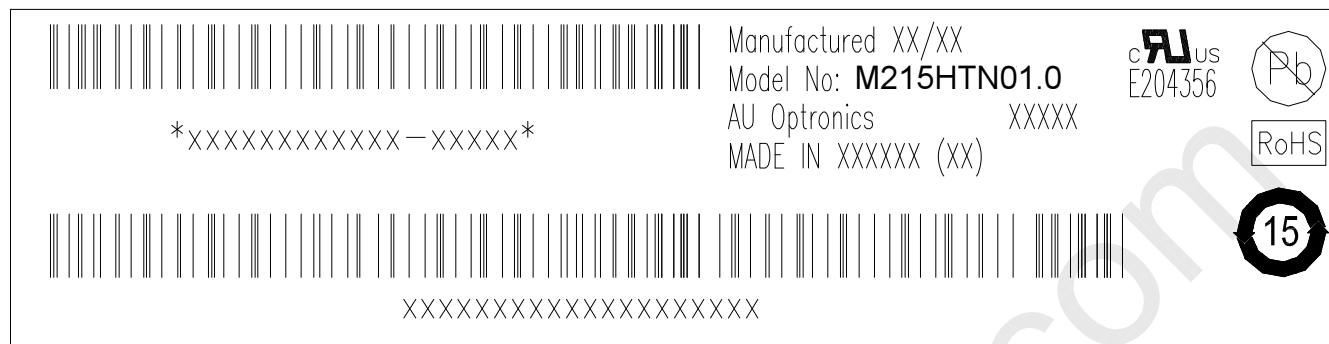

**Note 1:** For Pb Free products, AUO will add  for identification.

**Note 2:** For RoHS compatible products, AUO will add  for identification.

**Note 3:** For China RoHS compatible products, AUO will add  for identification.

**Note 4:** The Green Mark will be presented only when the green documents have been ready by AUO Internal Green Team.

## 10.0 Mechanical Characteristics

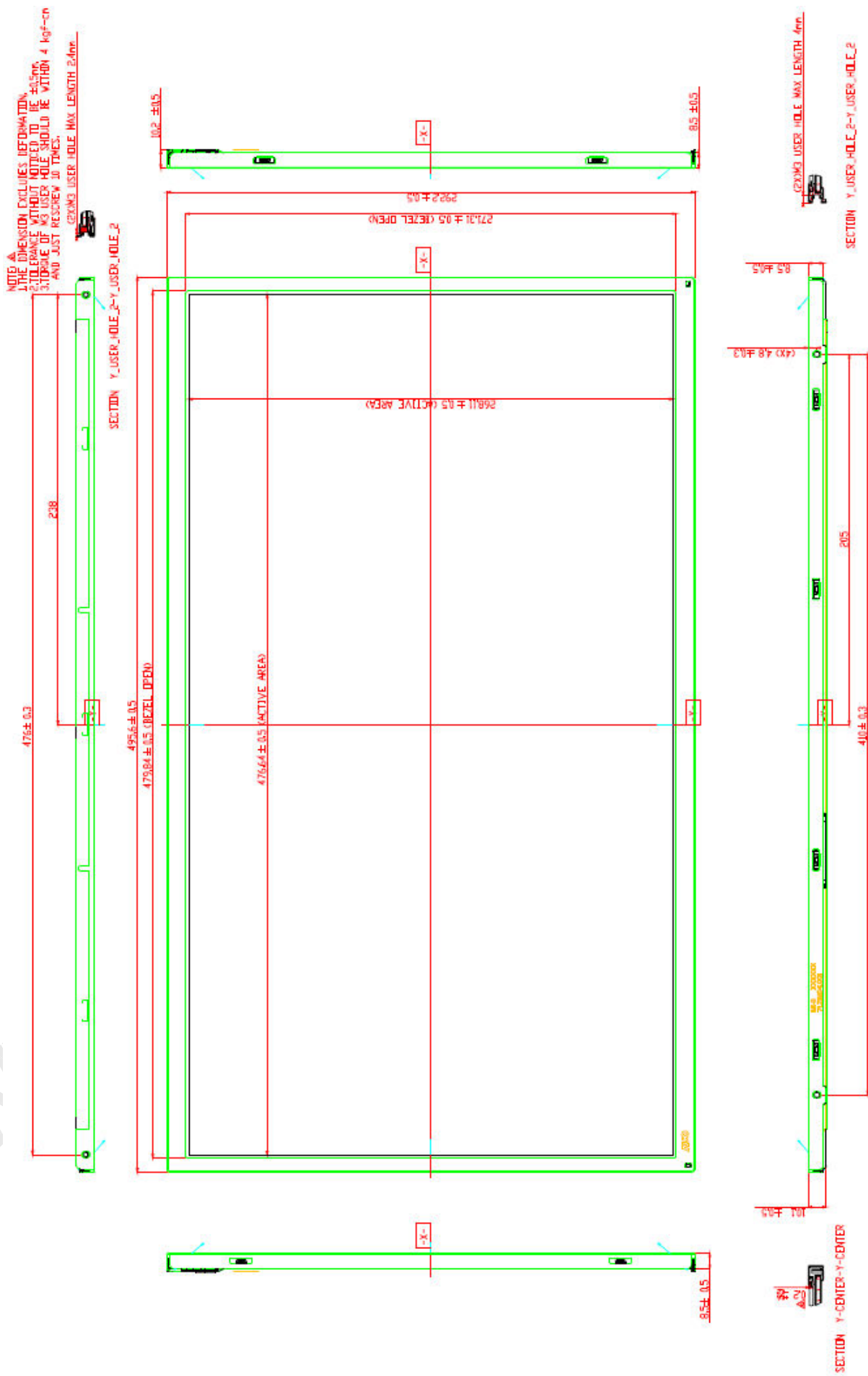

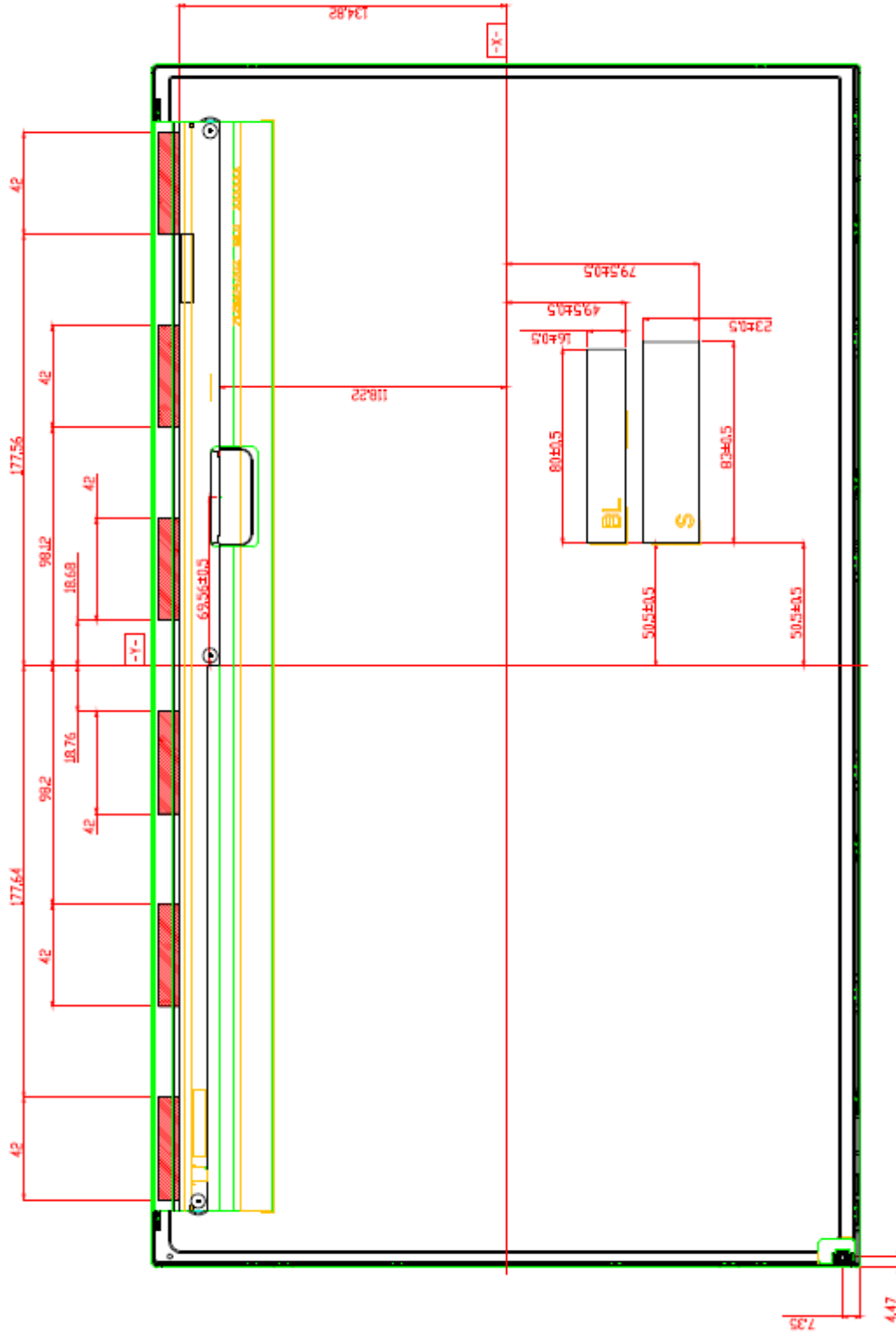

**Avoid touching COF position when doing mechanical design**



## 11. Packing Specification

### 11.1 Packing Flow

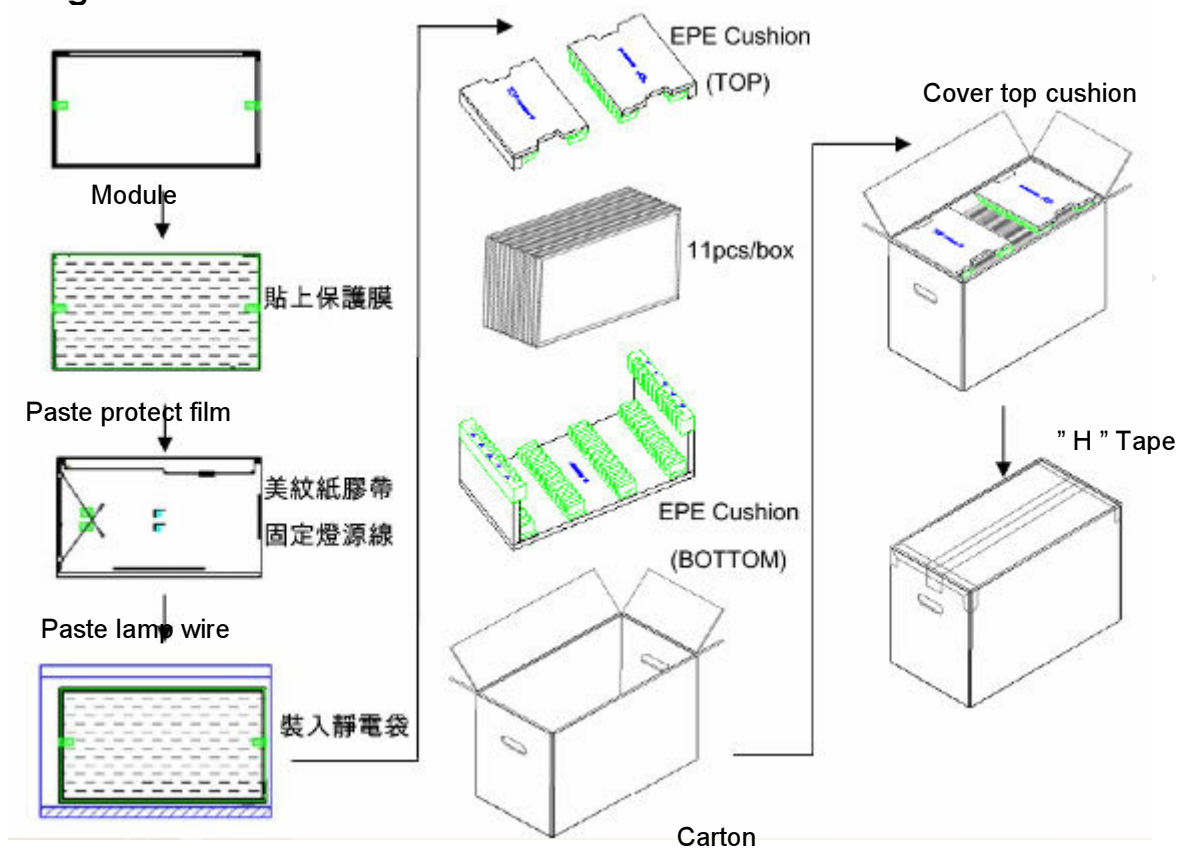

1pcs Module/ESD

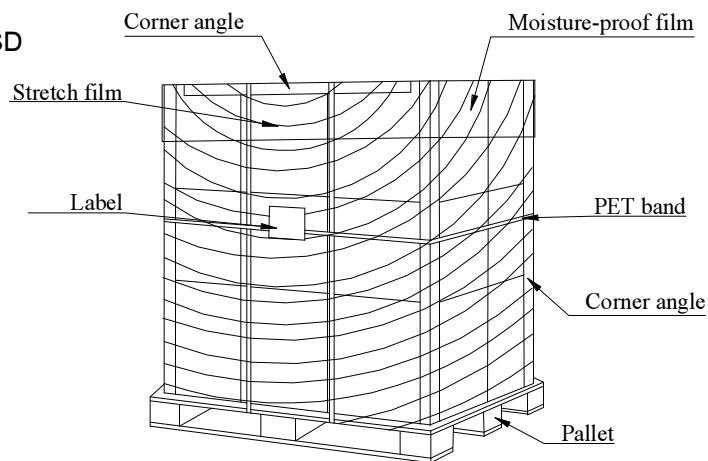

www.panelook.com



## 11.2. Pallet and shipment information

	Item	Specification			Remark
		Q'ty	Dimension	Weight(kg)	
1	Panel	1	495.6(W)mm × 292.2(H)mm × 11(D)mm	1.92	Note1
2	Cushion	1	-	0.40	
3	Box	1	556(L)mm x 292(W)mm x 375(H)mm	0.95	without Panel & cushion Note1
4	Packing Box	11 pcs/Box	556(L)mm x 292(W)mm x 375(H)mm	23.00	with panel & cushion Note1
5	Pallet	1	1150(L)mm x 910(W)mm x 132(H)mm	12.00	Note1
6	Pallet after Packing	18 boxes/pallet	1150(L)mm x 910(W)mm x 1257(H)mm	426.00	Note1

**Note 1:** Estimated value which is subject to change based on real measured data.