



() Preliminary Specification

(V) Final Specification

Module	21.5" Color TFT-LCD
Model Name	M215HTN01.3

Customer	Date
_____	_____
Approved by	
_____	_____

Approved by	Date
<u>Howard Lee</u>	<u>Nov 5, 2012</u>
Prepared by	Date
<u>Louis Jung</u>	<u>Nov 5, 2012</u>

Note: This Specification is subject to change without notice.

AU Optronics corporation

Contents

1 Handling Precautions	4
2 General Description	5
2.1 Display Characteristics.....	5
2.2 Optical Characteristics	6
3 Functional Block Diagram	10
4 Absolute Maximum Ratings	11
4.1 TFT LCD Module.....	11
4.2 Backlight Unit	11
4.3 Absolute Ratings of Environment.....	11
5 Electrical characteristics	13
5.1 TFT LCD Module.....	13
5.1.1 Power Specification.....	13
5.1.2 Signal Electrical Characteristics.....	14
6.0 Signal Characteristic	17
6.1 Pixel Format Definition	17
6.2 Input Data Format Definition	17
6.3 Signal Description	18
6.4 Timing Characteristics.....	20
6.5 Timing diagram	21
6.6 Power ON/OFF Sequence	22
7 Connector & Pin Assignment	23
7.1 TFT LCD Module.....	23
7.1.1 Pin Assignment	23
7.2 LED Connector on Backlight Unit.....	24
7.2.1 LED Pin assignment	24
7.2.2 LED Connector dimension	25
7.2.3 LED Mating housing dimension	25
8 Reliability Test	26
9 Shipping Label	27
10 Mechanical Characteristics	28
11. Packing Specification	29
11.1 Packing Flow.....	29
11. 2 Pallet and shipment information.....	30

Record of Revision

Version and Date	Page	Old description	New Description	Remark																																																																																																																																									
0.1 2012/06/26	All	First Edition for Customer	-																																																																																																																																										
2012/11/5	28			Revised																																																																																																																																									
	20	6.4 Timing Characteristics <table border="1"> <thead> <tr> <th>Signal</th> <th>Item</th> <th>Symbol</th> <th>Min</th> <th>Typ</th> <th>Max</th> <th>Unit</th> </tr> </thead> <tbody> <tr> <td rowspan="3">Vertical Section</td> <td>Period</td> <td>T_V</td> <td>1050</td> <td>1130</td> <td>1218</td> <td>Th</td> </tr> <tr> <td>Active</td> <td>$T_{disp}(V)$</td> <td>1080</td> <td>1080</td> <td>1080</td> <td>Th</td> </tr> <tr> <td>Blanking</td> <td>$T_{bp}(V)+T_{b}(V)+T_{W}(V)$</td> <td>25</td> <td>50</td> <td>738</td> <td>Th</td> </tr> <tr> <td rowspan="3">Horizontal Section</td> <td>Period</td> <td>T_H</td> <td>1034</td> <td>1050</td> <td>1100</td> <td>Th</td> </tr> <tr> <td>Active</td> <td>$T_{disp}(H)$</td> <td>960</td> <td>960</td> <td>960</td> <td>Th</td> </tr> <tr> <td>Blanking</td> <td>$T_{bp}(H)+T_{b}(H)+T_{W}(H)$</td> <td>74</td> <td>90</td> <td>140</td> <td>Th</td> </tr> <tr> <td rowspan="2">Clock</td> <td>Period</td> <td>T_{clk}</td> <td>10.6</td> <td>14</td> <td>17.5</td> <td>ns</td> </tr> <tr> <td>Frequency</td> <td>Freq</td> <td>57.1</td> <td>71.2</td> <td>94</td> <td>MHz</td> </tr> <tr> <td>Frame rate</td> <td>Frame rate</td> <td>F</td> <td>60</td> <td>60</td> <td>76</td> <td>Hz</td> </tr> </tbody> </table>	Signal	Item	Symbol	Min	Typ	Max	Unit	Vertical Section	Period	T_V	1050	1130	1218	Th	Active	$T_{disp}(V)$	1080	1080	1080	Th	Blanking	$T_{bp}(V)+T_{b}(V)+T_{W}(V)$	25	50	738	Th	Horizontal Section	Period	T_H	1034	1050	1100	Th	Active	$T_{disp}(H)$	960	960	960	Th	Blanking	$T_{bp}(H)+T_{b}(H)+T_{W}(H)$	74	90	140	Th	Clock	Period	T_{clk}	10.6	14	17.5	ns	Frequency	Freq	57.1	71.2	94	MHz	Frame rate	Frame rate	F	60	60	76	Hz	6.4 Timing Characteristics <table border="1"> <thead> <tr> <th>Signal</th> <th>Item</th> <th>Symbol</th> <th>Min</th> <th>Typ</th> <th>Max</th> <th>Unit</th> </tr> </thead> <tbody> <tr> <td rowspan="3">Vertical Section</td> <td>Period</td> <td>T_V</td> <td>1052</td> <td>1130</td> <td>1218</td> <td>Th</td> </tr> <tr> <td>Active</td> <td>$T_{disp}(V)$</td> <td>1080</td> <td>1080</td> <td>1080</td> <td>Th</td> </tr> <tr> <td>Blanking</td> <td>$T_{bp}(V)+T_{b}(V)+T_{W}(V)$</td> <td>12</td> <td>50</td> <td>738</td> <td>Th</td> </tr> <tr> <td rowspan="3">Horizontal Section</td> <td>Period</td> <td>T_H</td> <td>1034</td> <td>1050</td> <td>1100</td> <td>Th</td> </tr> <tr> <td>Active</td> <td>$T_{disp}(H)$</td> <td>960</td> <td>960</td> <td>960</td> <td>Th</td> </tr> <tr> <td>Blanking</td> <td>$T_{bp}(H)+T_{b}(H)+T_{W}(H)$</td> <td>74</td> <td>90</td> <td>140</td> <td>Th</td> </tr> <tr> <td rowspan="2">Clock</td> <td>Period</td> <td>T_{clk}</td> <td>10.6</td> <td>14</td> <td>17.7</td> <td>ns</td> </tr> <tr> <td>Frequency</td> <td>Freq</td> <td>57.1</td> <td>71.2</td> <td>94</td> <td>MHz</td> </tr> <tr> <td>Frame rate</td> <td>Frame rate</td> <td>F</td> <td>60</td> <td>60</td> <td>76</td> <td>Hz</td> </tr> <tr> <td>Hypec Frequency</td> <td>Hypec Frequency</td> <td>HFreq</td> <td>55</td> <td>68</td> <td>91</td> <td>KHz</td> </tr> </tbody> </table>	Signal	Item	Symbol	Min	Typ	Max	Unit	Vertical Section	Period	T_V	1052	1130	1218	Th	Active	$T_{disp}(V)$	1080	1080	1080	Th	Blanking	$T_{bp}(V)+T_{b}(V)+T_{W}(V)$	12	50	738	Th	Horizontal Section	Period	T_H	1034	1050	1100	Th	Active	$T_{disp}(H)$	960	960	960	Th	Blanking	$T_{bp}(H)+T_{b}(H)+T_{W}(H)$	74	90	140	Th	Clock	Period	T_{clk}	10.6	14	17.7	ns	Frequency	Freq	57.1	71.2	94	MHz	Frame rate	Frame rate	F	60	60	76	Hz	Hypec Frequency	Hypec Frequency	HFreq	55	68	91	KHz	Revised
Signal	Item	Symbol	Min	Typ	Max	Unit																																																																																																																																							
Vertical Section	Period	T_V	1050	1130	1218	Th																																																																																																																																							
	Active	$T_{disp}(V)$	1080	1080	1080	Th																																																																																																																																							
	Blanking	$T_{bp}(V)+T_{b}(V)+T_{W}(V)$	25	50	738	Th																																																																																																																																							
Horizontal Section	Period	T_H	1034	1050	1100	Th																																																																																																																																							
	Active	$T_{disp}(H)$	960	960	960	Th																																																																																																																																							
	Blanking	$T_{bp}(H)+T_{b}(H)+T_{W}(H)$	74	90	140	Th																																																																																																																																							
Clock	Period	T_{clk}	10.6	14	17.5	ns																																																																																																																																							
	Frequency	Freq	57.1	71.2	94	MHz																																																																																																																																							
Frame rate	Frame rate	F	60	60	76	Hz																																																																																																																																							
Signal	Item	Symbol	Min	Typ	Max	Unit																																																																																																																																							
Vertical Section	Period	T_V	1052	1130	1218	Th																																																																																																																																							
	Active	$T_{disp}(V)$	1080	1080	1080	Th																																																																																																																																							
	Blanking	$T_{bp}(V)+T_{b}(V)+T_{W}(V)$	12	50	738	Th																																																																																																																																							
Horizontal Section	Period	T_H	1034	1050	1100	Th																																																																																																																																							
	Active	$T_{disp}(H)$	960	960	960	Th																																																																																																																																							
	Blanking	$T_{bp}(H)+T_{b}(H)+T_{W}(H)$	74	90	140	Th																																																																																																																																							
Clock	Period	T_{clk}	10.6	14	17.7	ns																																																																																																																																							
	Frequency	Freq	57.1	71.2	94	MHz																																																																																																																																							
Frame rate	Frame rate	F	60	60	76	Hz																																																																																																																																							
Hypec Frequency	Hypec Frequency	HFreq	55	68	91	KHz																																																																																																																																							
	10	3. Functional Block Diagram	3. Functional Block Diagram	Revised																																																																																																																																									
	6	<table border="1"> <tr> <td>Green x</td> <td>0.287</td> <td>0.317</td> <td>0.347</td> </tr> <tr> <td>Green y</td> <td>0.601</td> <td>0.631</td> <td>0.661</td> </tr> </table>	Green x	0.287	0.317	0.347	Green y	0.601	0.631	0.661	<table border="1"> <tr> <td>Green x</td> <td>0.290</td> <td>0.320</td> <td>0.350</td> </tr> <tr> <td>Green y</td> <td>0.595</td> <td>0.625</td> <td>0.655</td> </tr> </table>	Green x	0.290	0.320	0.350	Green y	0.595	0.625	0.655	Revised																																																																																																																									
Green x	0.287	0.317	0.347																																																																																																																																										
Green y	0.601	0.631	0.661																																																																																																																																										
Green x	0.290	0.320	0.350																																																																																																																																										
Green y	0.595	0.625	0.655																																																																																																																																										
	22	<table border="1"> <thead> <tr> <th rowspan="2">Parameter</th> <th colspan="3">Value</th> <th rowspan="2">Unit</th> </tr> <tr> <th>Min.</th> <th>Typ.</th> <th>Max.</th> </tr> </thead> <tbody> <tr> <td>T1</td> <td>0.5</td> <td>-</td> <td>10</td> <td>[ms]</td> </tr> <tr> <td>T2</td> <td>0</td> <td>-</td> <td>50</td> <td>[ms]</td> </tr> <tr> <td>T3</td> <td>500</td> <td>-</td> <td>-</td> <td>[ms]</td> </tr> <tr> <td>T4</td> <td>100</td> <td>-</td> <td>-</td> <td>[ms]</td> </tr> <tr> <td>T5</td> <td>0</td> <td>-</td> <td>50</td> <td>[ms]</td> </tr> <tr> <td>T6</td> <td>5</td> <td>-</td> <td>100</td> <td>[ms] Note) 2</td> </tr> <tr> <td>T7</td> <td>1000</td> <td>-</td> <td>-</td> <td>[ms]</td> </tr> </tbody> </table>	Parameter	Value			Unit	Min.	Typ.	Max.	T1	0.5	-	10	[ms]	T2	0	-	50	[ms]	T3	500	-	-	[ms]	T4	100	-	-	[ms]	T5	0	-	50	[ms]	T6	5	-	100	[ms] Note) 2	T7	1000	-	-	[ms]	<table border="1"> <thead> <tr> <th rowspan="2">Parameter</th> <th colspan="3">Value</th> <th rowspan="2">Unit</th> </tr> <tr> <th>Min.</th> <th>Typ.</th> <th>Max.</th> </tr> </thead> <tbody> <tr> <td>T1</td> <td>0.5</td> <td>-</td> <td>10</td> <td>[ms]</td> </tr> <tr> <td>T2</td> <td>0</td> <td>-</td> <td>50</td> <td>[ms]</td> </tr> <tr> <td>T3</td> <td>500</td> <td>-</td> <td>-</td> <td>[ms]</td> </tr> <tr> <td>T4</td> <td>100</td> <td>-</td> <td>-</td> <td>[ms]</td> </tr> <tr> <td>T5</td> <td>0</td> <td>-</td> <td>50</td> <td>[ms]</td> </tr> <tr> <td>T6</td> <td>0</td> <td>-</td> <td>100</td> <td>[ms] Note) 2</td> </tr> <tr> <td>T7</td> <td>1000</td> <td>-</td> <td>-</td> <td>[ms]</td> </tr> </tbody> </table>	Parameter	Value			Unit	Min.	Typ.	Max.	T1	0.5	-	10	[ms]	T2	0	-	50	[ms]	T3	500	-	-	[ms]	T4	100	-	-	[ms]	T5	0	-	50	[ms]	T6	0	-	100	[ms] Note) 2	T7	1000	-	-	[ms]	Revised																																																			
Parameter	Value			Unit																																																																																																																																									
	Min.	Typ.	Max.																																																																																																																																										
T1	0.5	-	10	[ms]																																																																																																																																									
T2	0	-	50	[ms]																																																																																																																																									
T3	500	-	-	[ms]																																																																																																																																									
T4	100	-	-	[ms]																																																																																																																																									
T5	0	-	50	[ms]																																																																																																																																									
T6	5	-	100	[ms] Note) 2																																																																																																																																									
T7	1000	-	-	[ms]																																																																																																																																									
Parameter	Value			Unit																																																																																																																																									
	Min.	Typ.	Max.																																																																																																																																										
T1	0.5	-	10	[ms]																																																																																																																																									
T2	0	-	50	[ms]																																																																																																																																									
T3	500	-	-	[ms]																																																																																																																																									
T4	100	-	-	[ms]																																																																																																																																									
T5	0	-	50	[ms]																																																																																																																																									
T6	0	-	100	[ms] Note) 2																																																																																																																																									
T7	1000	-	-	[ms]																																																																																																																																									
1.0 2012/11/5		Final version 1.0																																																																																																																																											

1 Handling Precautions

- 1) Since front polarizer is easily damaged, pay attention not to scratch it.
- 2) Be sure to turn off power supply when inserting or disconnecting from input connector.
- 3) Wipe off water drop immediately. Long contact with water may cause discoloration or spots.
- 4) When the panel surface is soiled, wipe it with absorbent cotton or other soft cloth.
- 5) Since the panel is made of glass, it may break or crack if dropped or bumped on hard surface.
- 6) Since CMOS LSI is used in this module, take care of static electricity and insure human earth when handling.
- 7) Do not open or modify the Module Assembly.
- 8) Do not press the reflector sheet at the back of the module to any directions.
- 9) In case if a Module has to be put back into the packing container slot after once it was taken out from the container, do not press the center of the LED lightbar edge. Instead, press at the far ends of the LED light bar edge softly. Otherwise the TFT Module may be damaged.
- 10) At the insertion or removal of the Signal Interface Connector, be sure not to rotate nor tilt the Interface Connector of the TFT Module.
- 11) After installation of the TFT Module into an enclosure, do not twist nor bend the TFT Module even momentary. At designing the enclosure, it should be taken into consideration that no bending/twisting forces are applied to the TFT Module from outside. Otherwise the TFT Module may be damaged.
- 12) Small amount of materials having no flammability grade is used in the LCD module. The LCD module should be supplied by power complied with requirements of Limited Power Source (IEC60950 or UL1950), or be applied exemption.
- 13) Pls avoid touching COF position while you are doing mechanical design.
- 14) When storing modules as spares for a long time, the following precaution is necessary:
Store them in a dark place. Do not expose the module to sunlight or fluorescent light. Keep the temperature between 5°C and 35°C at normal humidity.

2 General Description

This specification applies to the 21.5 inch-wide Color a-Si TFT-LCD Module M215HTN01.3. The display supports the Full HD - 1920(H) x 1080(V) screen format and 16.7M colors (RGB 6-bits + Hi-FRC data). All input signals are 2-channel LVDS interface and this module doesn't contain an driver board for backlight.

2.1 Display Characteristics

The following items are characteristics summary on the table under 25°C condition:

ITEMS	Unit	SPECIFICATIONS
Screen Diagonal	[mm]	546.86(21.53")
Active Area	[mm]	476.64 (H) x 268.11 (V)
Pixels H x V		1920(x3) x 1080
Pixel Pitch	[um]	248.25 (per one triad) x 248.25
Pixel Arrangement		R.G.B. Vertical Stripe
Display Mode		TN Mode, Normally White
White Luminance (Center)	[cd/m ²]	200cd/m ² (Typ.)
Contrast Ratio		600 (Typ.)
Optical Response Time	[msec]	5ms (Typ., on/off)
Nominal Input Voltage VDD	[Volt]	+5.0 V
Power Consumption (VDD line + LED line)	[Watt]	13.97W (Typ) VDD line : PDD (typ), All black pattern at 60Hz = 5.65W LED line : PBLU (typ) = 8.32 W
Weight	[Grams]	1750
Physical Size	[mm]	495.6(W) x 292.2(H) x 10.3(D) Typ.
Electrical Interface		Dual channel LVDS
Support Color		16.7M colors (RGB 6-bit + Hi_FRC)
Surface Treatment		Anti-Glare, 3H
Temperature Range		
Operating	[°C]	0 to +50
Storage (Shipping)	[°C]	-20 to +60
RoHS Compliance		RoHS Compliance
TCO Compliance		No Compliance

2.2 Optical Characteristics

The optical characteristics are measured under stable conditions at 25°C:

Item	Unit	Conditions	Min.	Typ.	Max.	Note
Viewing Angle	[degree]	Horizontal (Right) CR = 10 (Left)	40 40	45 45	- -	2
		Vertical (Up) CR = 10 (Down)	15 40	20 45	- -	
Contrast ratio		Normal Direction	360	600	-	3
Response Time	[msec]	Raising Time (T _{rR})	-	3.8	5.5	4
		Falling Time (T _{rF})	-	1.2	2.5	
		Raising + Falling	-	5	8	
Color / Chromaticity Coordinates (CIE)		Red x	0.615	0.645	0.675	5
		Red y	0.302	0.332	0.362	
		Green x	0.290	0.320	0.350	
		Green y	0.595	0.625	0.655	
		Blue x	0.127	0.157	0.187	
		Blue y	0.030	0.060	0.090	
Color Coordinates (CIE) White		White x	0.283	0.313	0.343	5
		White y	0.299	0.329	0.359	
Central Luminance	[cd/m ²]		160	200	-	6
Luminance Uniformity	[%]		75	80	-	7
Crosstalk (in 60Hz)	[%]				1.5	8
Flicker	dB				-20	9

Note 1: Measurement method

The LCD module should be stabilized at given temperature for 30 minutes to avoid abrupt temperature change during measuring (at surface 35°C). In order to stabilize the luminance, the measurement should be executed after lighting Backlight for 30 minutes in a stable, windless and dark room.

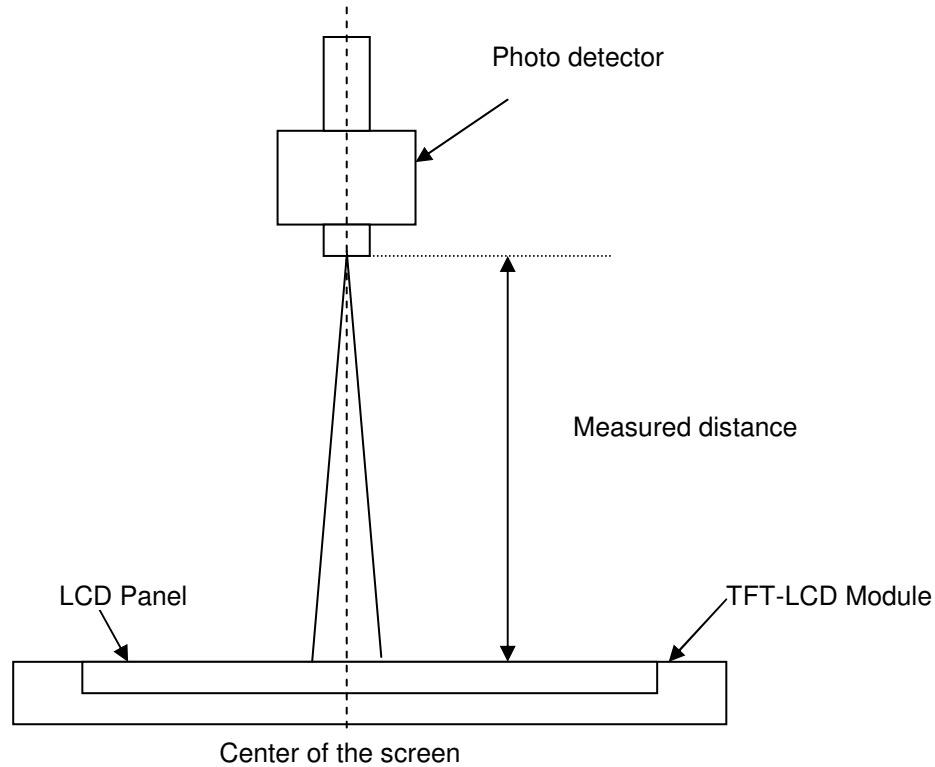

Note 2: Definition of viewing angle measured by ELDIM (EZContrast 88)

Viewing angle is the measurement of contrast ratio ≥ 10 , at the screen center, over a 180° horizontal and 180° vertical range (off-normal viewing angles). The 180° viewing angle range is broken down as follows; 90° (θ) horizontal left and right and 90° (ϕ) vertical, high (up) and low (down). The measurement direction is typically perpendicular to the display surface with the screen rotated about its center to develop the desired measurement viewing angle.

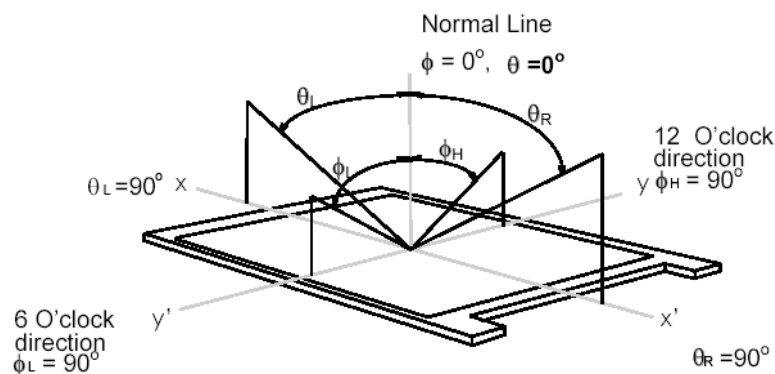

Note 3: Contrast ratio is measured by TOPCON SR-3

Note 4: Definition of Response time measured by Westar TRD-100A

The output signals of photo detector are measured when the input signals are changed from “Full Black” to “Full White” (rising time, T_{rR}), and from “Full White” to “Full Black” (falling time, T_{rF}), respectively. The response time is interval between the 10% and 90% (1 frame at 60 Hz) of amplitudes.

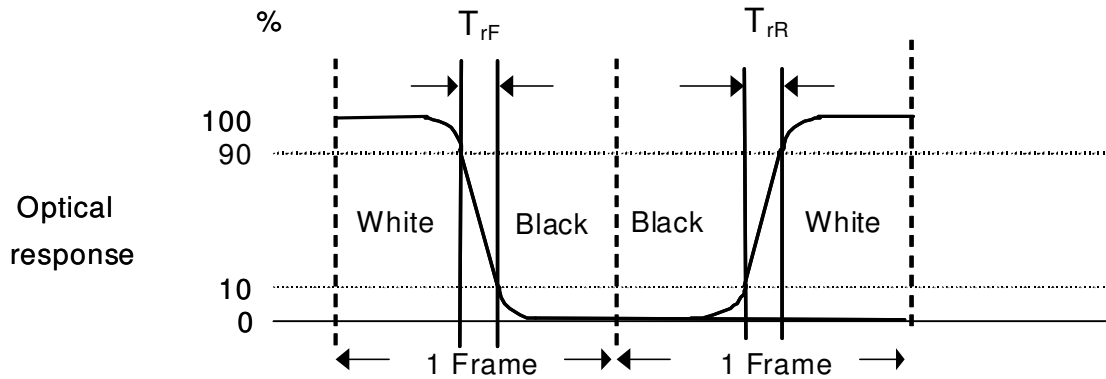

$T_{rR} + T_{rF} = 5 \text{ msec (typ.)}$.

Note 5: Color chromaticity and coordinates (CIE) is measured by TOPCON SR-3

Note 6: Central luminance is measured by TOPCON SR-3

Note 7: Luminance uniformity of these 9 points is defined as below and measured by TOPCON SR-3

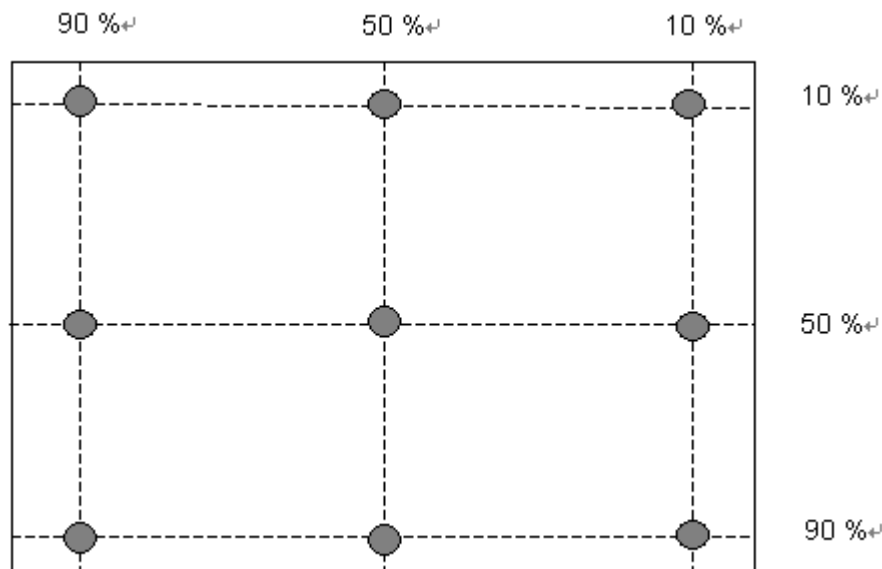

$$\text{Uniformity} = \frac{\text{Minimum Luminance in 9 points (1-9)}}{\text{Maximum Luminance in 9 Points (1-9)}}$$

Note 8: Crosstalk is defined as below and measured by TOPCON SR-3

$$CT = | YB - YA | / YA \times 100 (\%)$$

Where

YA = Luminance of measured location without gray level 0 pattern (cd/m²)

YB = Luminance of measured location with gray level 0 pattern (cd/m²)

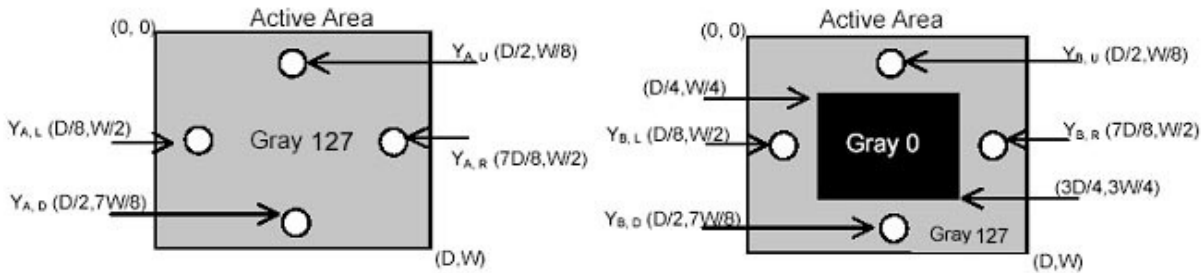

Note 9: Test Pattern: Subchecker Pattern measured by TOPCON SR-3

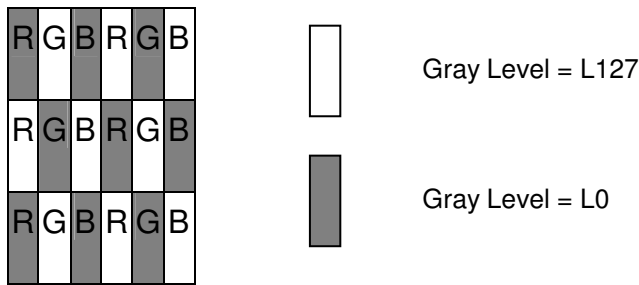

Method: Record dBV & DC value with TRD-100

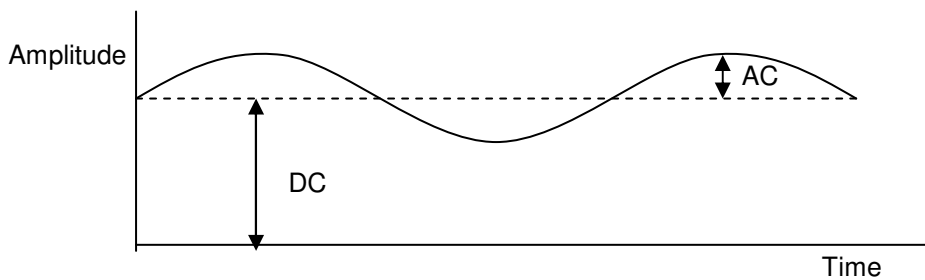

$$\text{Flicker (dB)} = 20 \log \frac{\text{AC Level (at 30 Hz)}}{\text{DC Level}}$$

3 Functional Block Diagram

The following diagram shows the functional block of the 21.5 inch Color TFT-LCD Module:

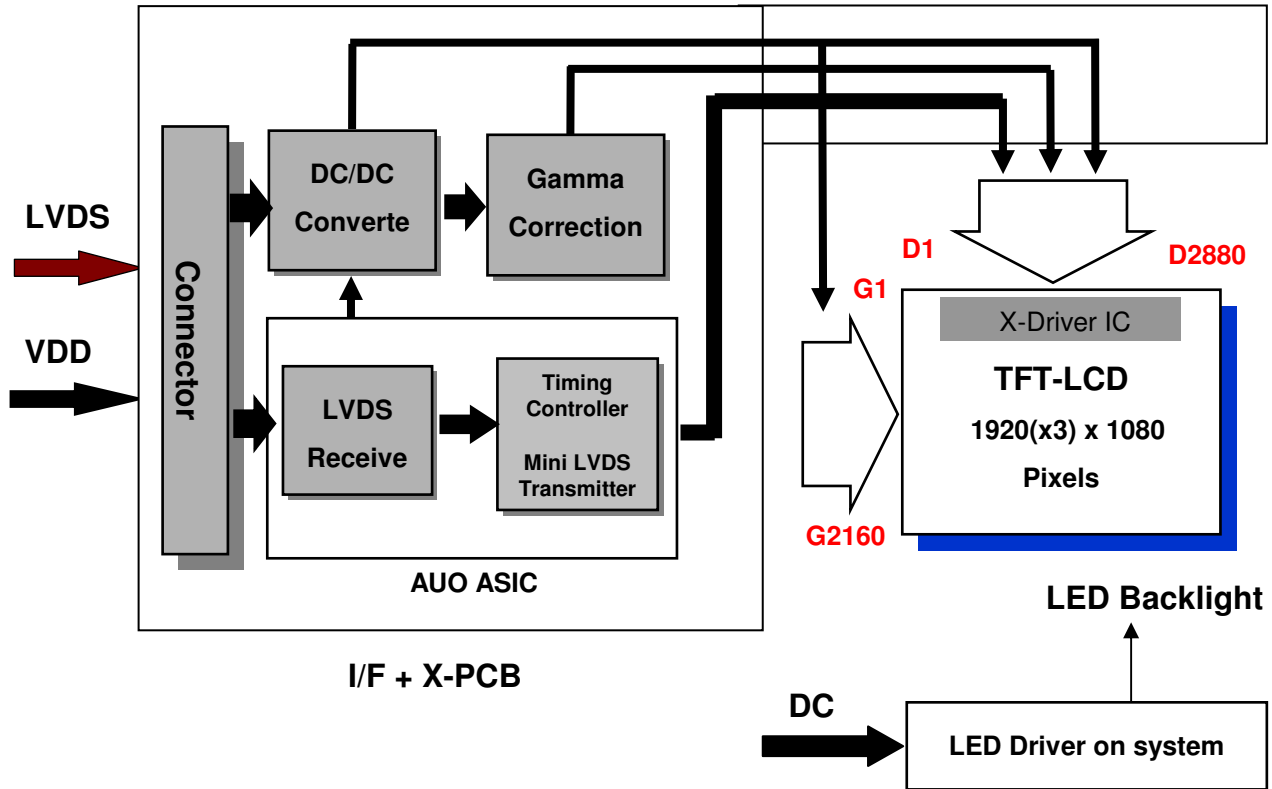

4 Absolute Maximum Ratings

Absolute maximum ratings of the module are as following:

4.1 TFT LCD Module

Item	Symbol	Min	Max	Unit	Conditions
Logic/LCD Drive Voltage	VDD	-0.3	6.0	[Volt]	Note 1,2

4.2 Backlight Unit

Item	Symbol	Min	Max	Unit	Conditions
LED Forward Current	IRLED1	0	90	[mA]	Note 1,2,5 100% duty
	IRLED2				
	IRLED3				
	IRLED4				
LED Pulse Forward Current	IPLD1	-	150	[mA]	Note 1,2,5 10% duty @100Hz
	IPLD2				
	IPLD3				
	IPLD4				
LED forward Voltage variation (per string variation)	ΔV_f	-	2	[Volt]	Note 1,2

4.3 Absolute Ratings of Environment

Item	Symbol	Min.	Max.	Unit	Conditions
Operating Temperature	TOP	0	+50	[°C]	Note 3
Glass surface temperature (operation)	TGS	0	+65	[°C]	Note 3, Note 4
Operation Humidity	HOP	5	90	[%RH]	Note 3
Storage Temperature	TST	-20	+60	[°C]	
Storage Humidity	HST	5	90	[%RH]	

Note 1: With in Ta (25°C)

Note 2: Permanent damage to the device may occur if exceeding maximum values

Note 3: Temperature and relative humidity range are shown as the below figure.

1. 90% RH Max (Ta ≤ 39°C)
2. Max wet-bulb temperature at 39°C or less. (Ta ≤ 39°C)
3. No condensation

Note 4: *Function Judged only*

Note 5: IRLED1,2,3,4 and IPLD1,2,3,4 define as per strings LED current.

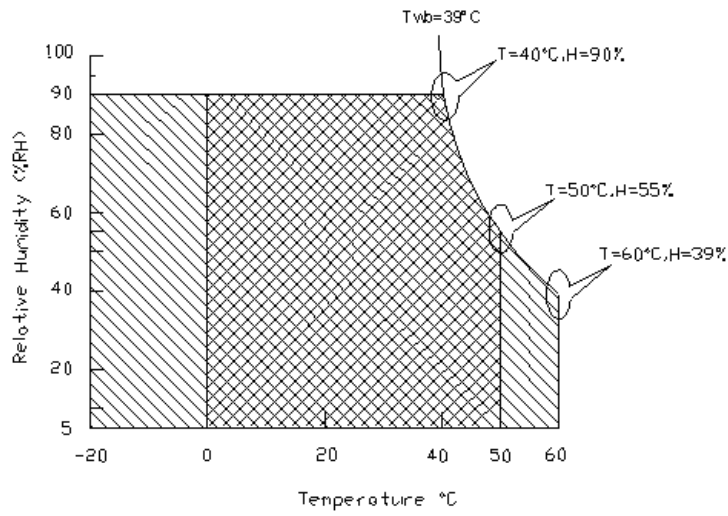

Operating Range



Storage Range

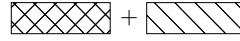

5 Electrical characteristics

5.1 TFT LCD Module

5.1.1 Power Specification

Input power specifications are as following:

Symbol	Parameter	Min	Typ	Max	Unit	Conditions
VDD	Logic/LCD Drive Voltage	4.5	5.0	5.5	[Volt]	+/-10%
IDD	Input Current	-	1.13	1.36	[A]	VDD= 5.0V, All Black Pattern At 60Hz
		-	1.34	1.61	[A]	VDD= 5.0V, All Black Pattern At 75Hz
PDD	VDD Power	-	5.65	6.80	[Watt]	VDD= 5.0V, All Black Pattern At 60Hz
		-	6.7	8.05	[Watt]	VDD= 5.0V, All Black Pattern At 75Hz
IRush	Inrush Current	-	-	3	[A]	Note 1
VDDrp	Allowable Logic/LCD Drive Ripple Voltage	-	-	500	[mV] p-p	VDD= 5.0V, All Black Pattern At 75Hz

Note 1: Measurement conditions:

The duration of rising time of power input is 470us.

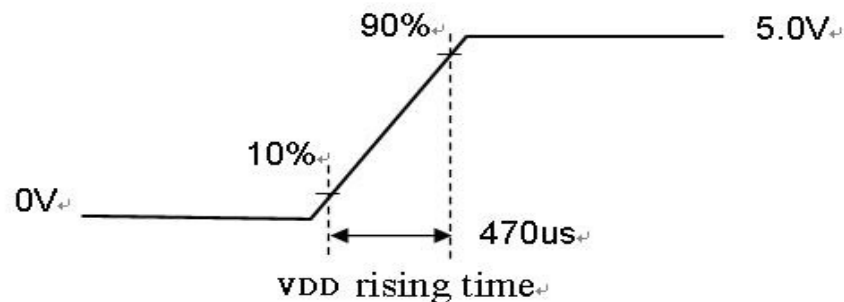
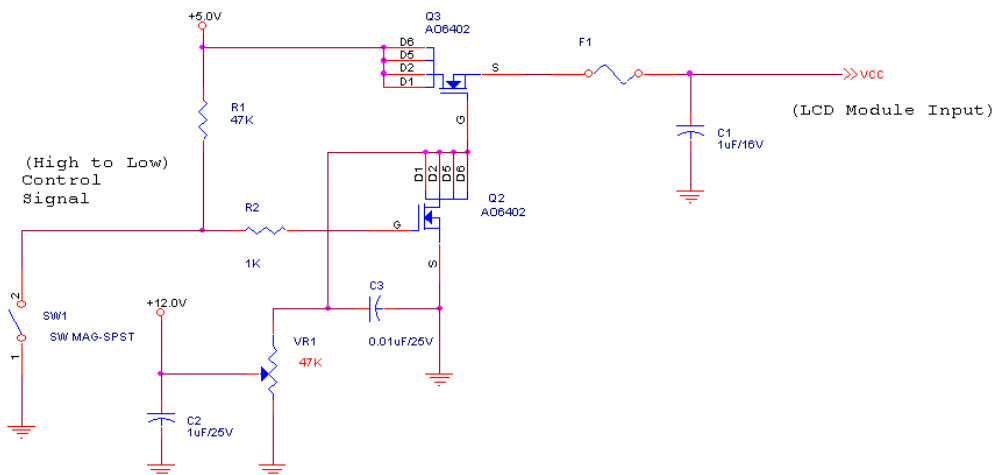

5.1.2 Signal Electrical Characteristics

1. DC Characteristics of each signal are as following:

Symbol	Parameter	Min	Typ	Max	Units	Condition
V _{TH}	Differential Input High Threshold	-	-	+100	[mV]	V _{ICM} = 1.2V Note 1
V _{TL}	Differential Input Low Threshold	-100	-	-	[mV]	V _{ICM} = 1.2V Note 1
V _{ID}	Input Differential Voltage	100	-	600	[mV]	Note 1
V _{ICM}	Differential Input Common Mode Voltage	+1.0	+1.2	+1.5	[V]	V _{TH} -V _{TL} = 200mV (max) Note 1

Note 1: LVDS Signal Waveform

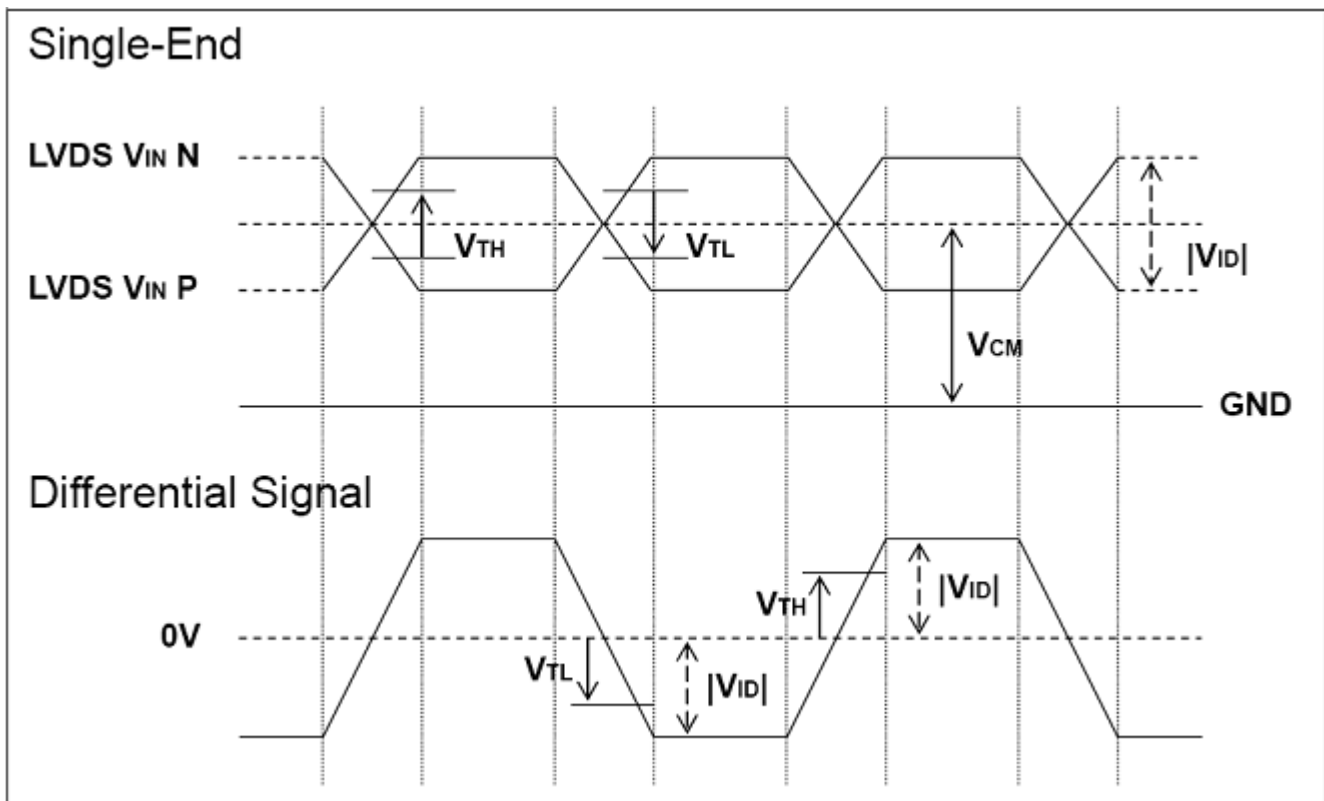

2. AC Characteristics

Description	Symbol	Min	Max	Unit	Note
Maximum deviation of input clock frequency during SSC	F_{DEV}	-	± 3	%	
Maximum modulation frequency of input clock during SSC	F_{MOD}	-	200	KHz	

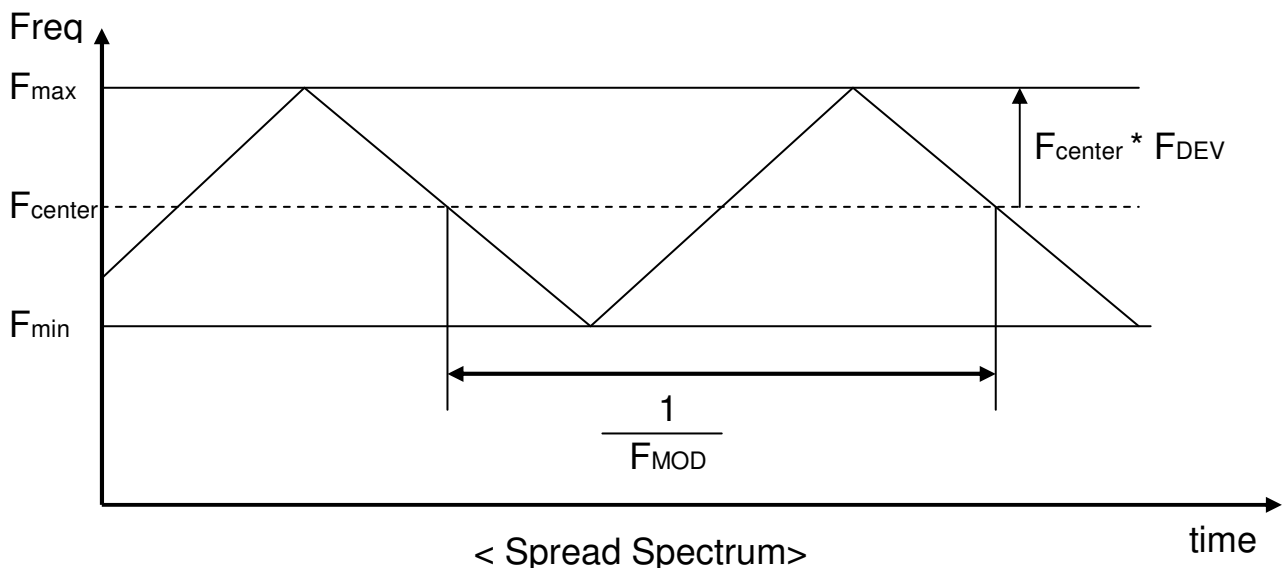

5.2 Backlight Unit

Parameter guideline for LED driver is under stable conditions at 25°C (Room Temperature):

Symbol	Description	Min.	Typ.	Max.	Unit	Note
IRLED1	LED Forward Current	-	65	68	[mA]	Note 1
IRLED2						
IRLED3						
IRLED4						
VLED	Light Bar Operation Voltage	30	32	36	[Volt]	Note 2
PBLU	BLU Power Consumption	-	8.32	9.792	[Watt]	Note 3
LTLED	LED Life Time (Typical)	30,000	-	-	[Hour]	Note 4

Each module consists of 40 pcs LED (4 strings x 10 pcs / string)

Note 1: The specified current is 100% duty of LED chip input current, IRLED1,2,3,4 define as per strings LED current.

Note 2: The value showed is one string operation voltage.

Note 3: $PBLU = VLED * (IRLED1 + IRLED2 + IRLED3 + IRLED4)$

Note 4: Definition of life time: Brightness becomes to 50% of its original value. The minimum life time of LED unit is on the condition of IRLED = 65mA and 25±2°C (Room Temperature).

6.0 Signal Characteristic

6.1 Pixel Format Definition

Following figure shows the relationship of the input signals and LCD pixel format.

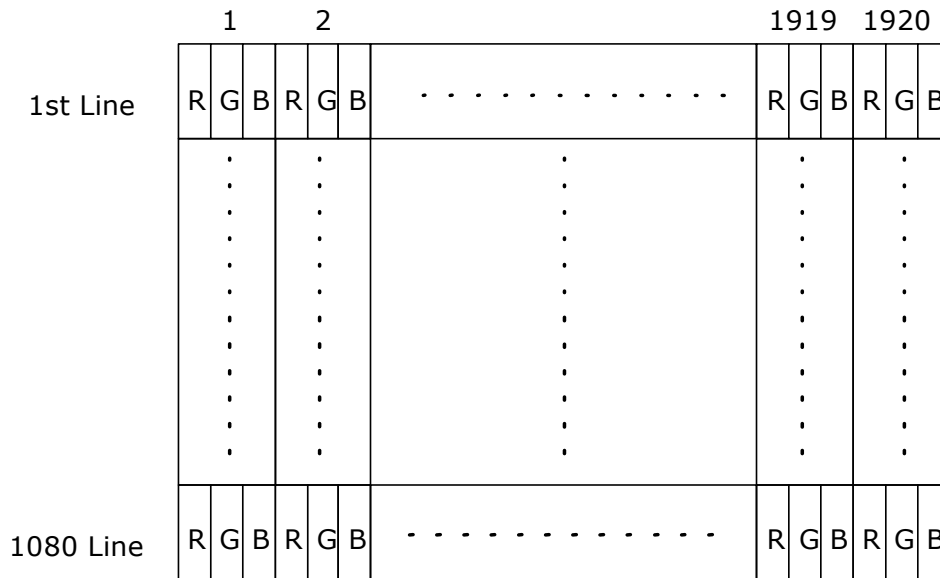

6.2 Input Data Format Definition

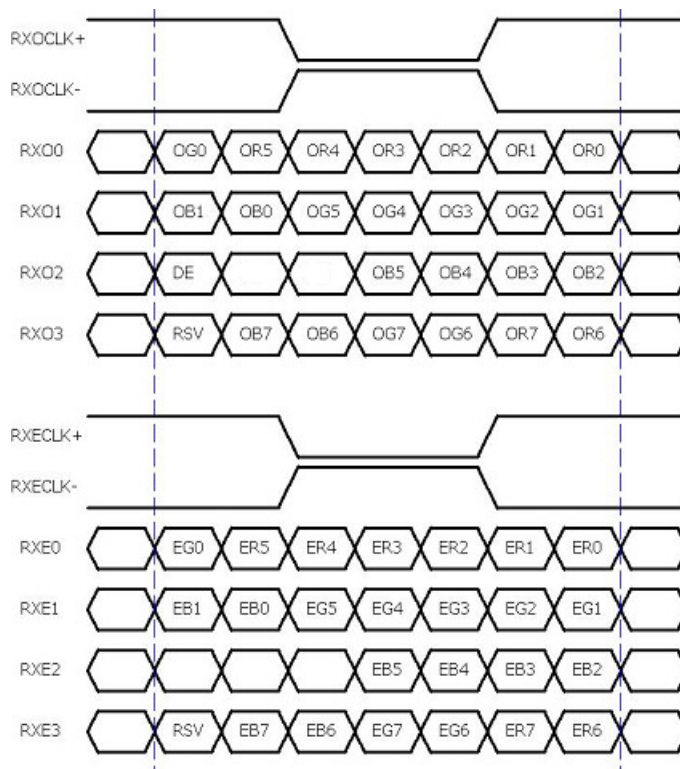

Note 1: R/G/B data 7:MSB, R/G/B data 0:LSB O = "Odd Pixel Data" E = "Even Pixel Data"

6.3 Signal Description

PIN #	SIGNAL NAME	DESCRIPTION
1	RxO0-	Negative LVDS differential data input (Odd data)
2	RxO0+	Positive LVDS differential data input (Odd data)
3	RxO1-	Negative LVDS differential data input (Odd data)
4	RxO1+	Positive LVDS differential data input (Odd data)
5	RxO2-	Negative LVDS differential data input (Odd data)
6	RxO2+	Positive LVDS differential data input (Odd data)
7	GND	Power Ground
8	RxOCLK-	Negative LVDS differential clock input (Odd clock)
9	RxOCLK+	Positive LVDS differential clock input (Odd clock)
10	RxO3-	Negative LVDS differential data input (Odd data)
11	RxO3+	Positive LVDS differential data input (Odd data)
12	RxE0-	Negative LVDS differential data input (Even data)
13	RxE0+	Positive LVDS differential data input (Even data)
14	GND	Power Ground
15	RxE1-	Negative LVDS differential data input (Even data)
16	RxE1+	Positive LVDS differential data input (Even data)
17	GND	Power Ground
18	RxE2-	Negative LVDS differential data input (Even data)
19	RxE2+	Positive LVDS differential data input (Even data)
20	RxECLK-	Negative LVDS differential clock input (Even clock)
21	RxECLK+	Positive LVDS differential clock input (Even clock)
22	RxE3-	Negative LVDS differential data input (Even data)
23	RxE3+	Positive LVDS differential data input (Even data)
24	GND	Power Ground
25	NC	No connection (for AUO test only. Do not connect)
26	NC	No connection (for AUO test only. Do not connect)
27	NC	No connection (for AUO test only. Do not connect)
28	VDD	Power +5V
29	VDD	Power +5V
30	VDD	Power +5V

Note 1: Input signals of odd and even clock shall be the same timing.

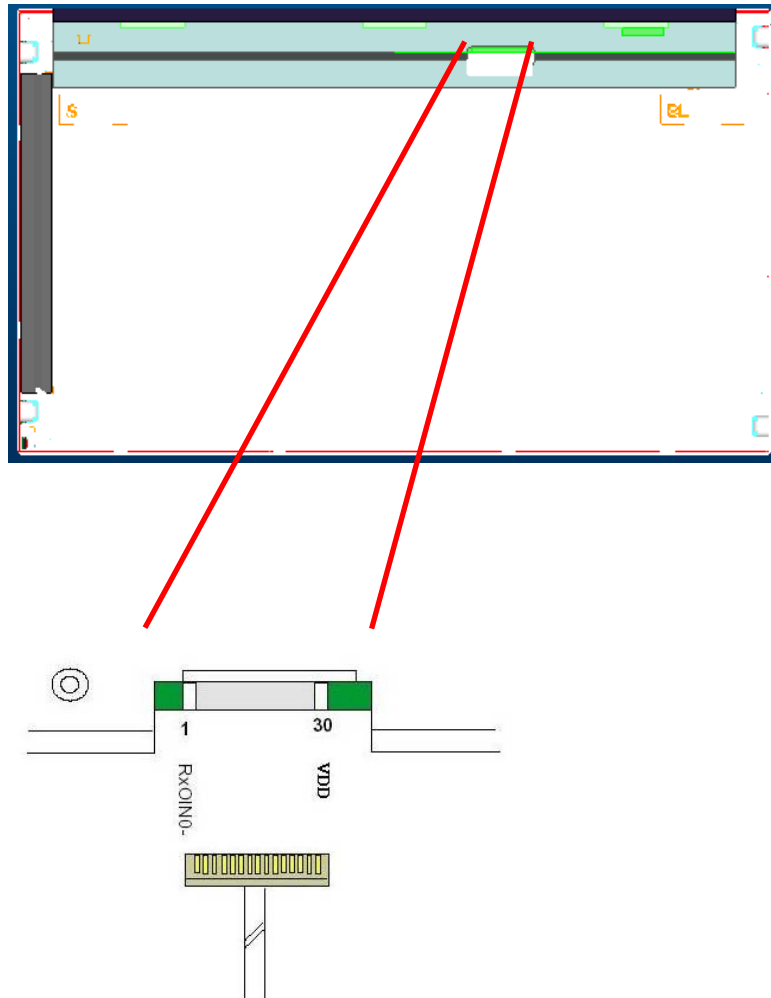

6.4 Timing Characteristics

The input signal timing specifications are shown as the following table

Signal	Item	Symbol	Min	Typ	Max	Unit
Vertical Section	Period	T_v	1092	1130	1818	Th
	Active	$T_{disp(v)}$	1080	1080	1080	Th
	Blanking	$T_{bp(v)}+T_{fp(v)}+PW_{vs}$	12	50	738	Th
Horizontal Section	Period	T_h	1034	1050	1100	Tclk
	Active	$T_{disp(h)}$	960	960	960	Tclk
	Blanking	$T_{bp(h)}+T_{fp(h)}+PW_{hs}$	74	90	140	Tclk
Clock	Period	Tclk	10.6	14.0	17.7	ns
	Frequency	Freq	56.5	71.2	94.0	MHz
Frame rate	Frame rate	F	50	60	76	Hz
Hsync Frequency	Hsync Frequency	HFreq	55	68	91	KHz

Note : DE mode only

6.5 Timing diagram

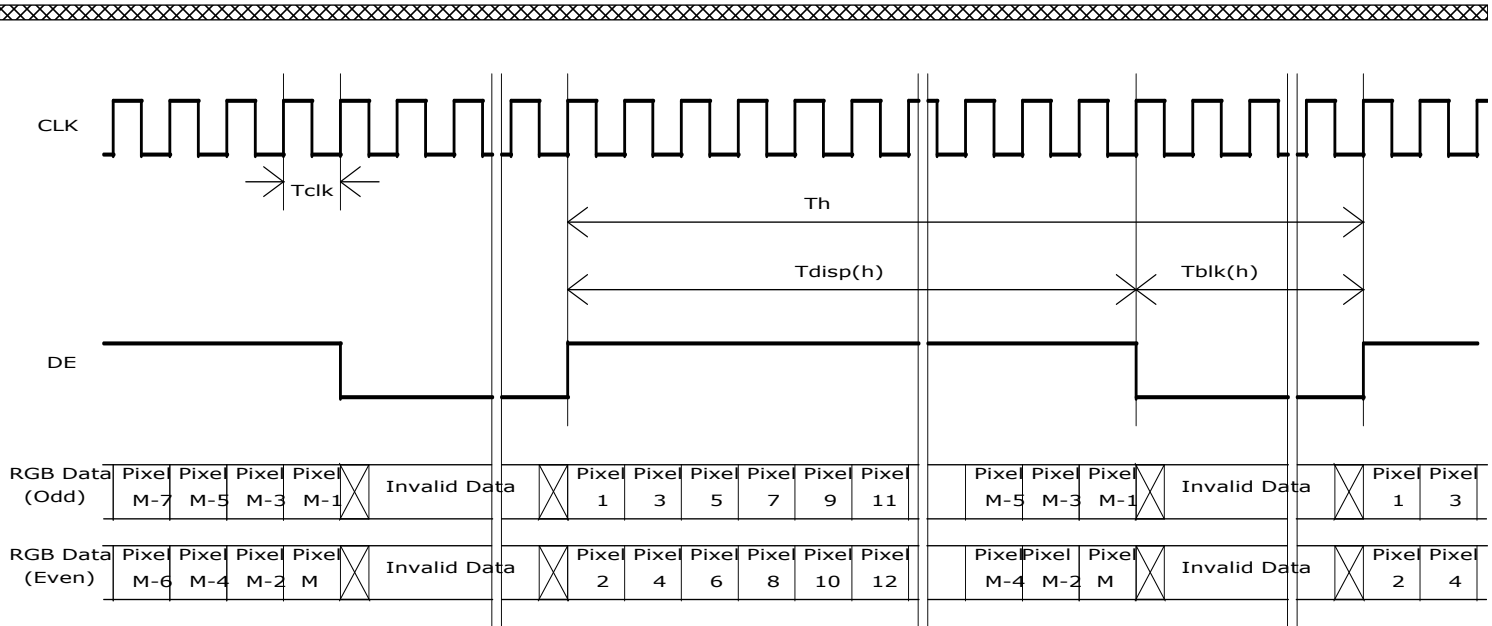
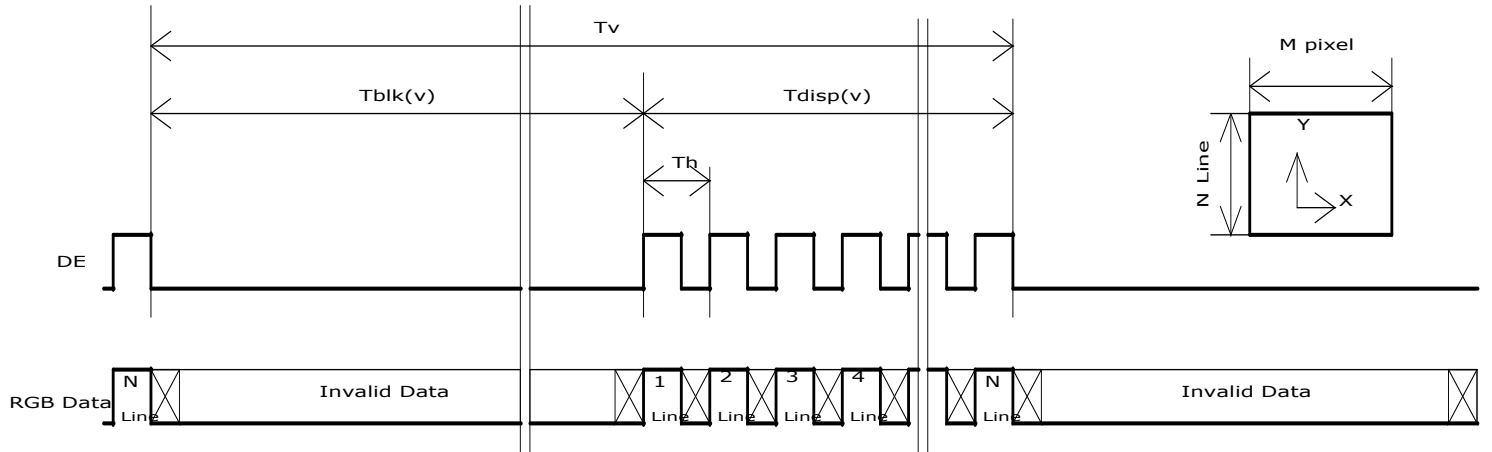

6.6 Power ON/OFF Sequence

VDD power and backlight on/off sequence are as follows. Interface signals are also shown in the chart. Signals from any system shall be Hi-Z state or low level when VDD is off.

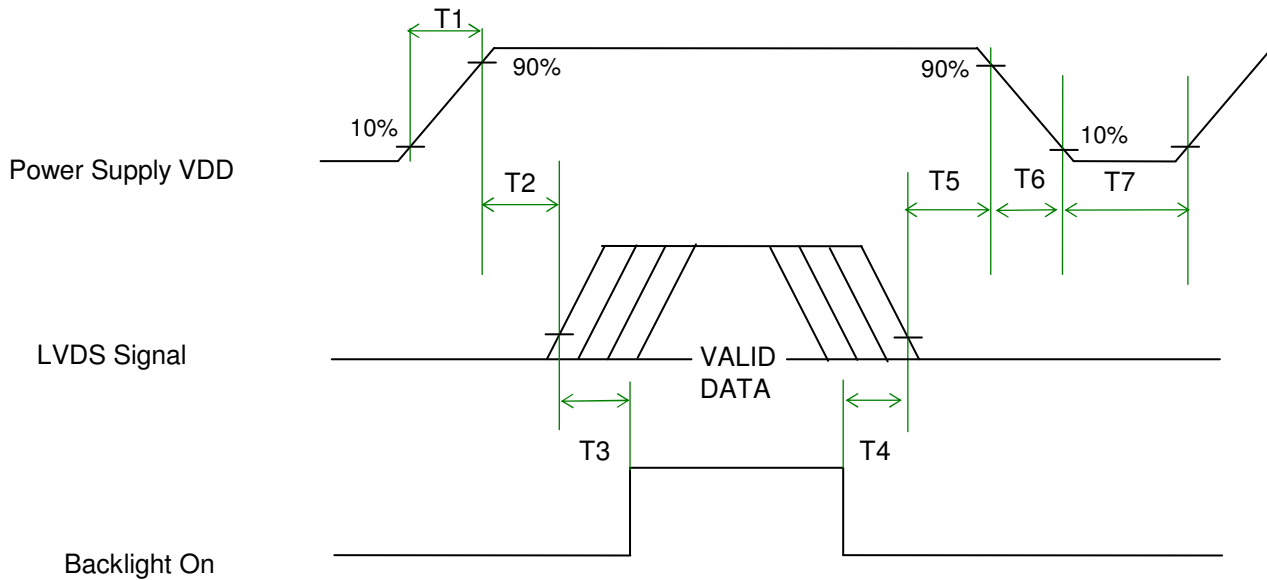

Power Sequence Timing

Parameter	Value			Unit
	Min.	Typ.	Max.	
T1	0.5	-	10	[ms]
T2	0	-	50	[ms]
T3	500	-	-	[ms]
T4	100	-	-	[ms]
T5	0	-	50	[ms] Note1,2
T6	0	-	100	[ms] Note1,2
T7	1000	-	-	[ms]

Note1 : Recommend setting T5 = 0ms to avoid electronic noise when VDD is off.

Note2 : During T5 and T6 period , please keep the level of input LVDS signals with Hi-Z state.

7 Connector & Pin Assignment

Physical interface is described as for the connector on module. These connectors are capable of accommodating the following signals and will be following components.

7.1 TFT LCD Module

Connector Name / Designation	Interface Connector / Interface card
Manufacturer	P-TWO, STM
Type Part Number	P-TWO AL230F-A0G1D-P STM MSCKT2407P30HB
Mating Housing Part Number	FI-X30HL (Locked Type)

7.1.1 Pin Assignment

Pin#	Signal Name	Pin#	Signal Name
1	RxO0-	2	RxO0+
3	RxO1-	4	RxO1+
5	RxO2-	6	RxO2+
7	GND	8	RxOCLKIN-
9	RxOCLKIN+	10	RxO3-
11	RxO3+	12	RxE0-
13	RxE0+	14	GND
15	RxE1-	16	RxE1+
17	GND	18	RxE2-
19	RxE2+	20	RxECLKIN-
21	RxECLKIN+	22	RxE3-
23	RxE3+	24	GND
25	NC (for AUO test only. Do not connect)	26	NC (for AUO test only. Do not connect)
27	NC (for AUO test only. Do not connect)	28	VDD
29	VDD	30	VDD

7.2 LED Connector on Backlight Unit.

This connector is mounted on LED light-bar.

Connector Name / Designation	Light Bar Connector
Manufacturer	ENTERY
Type Part Number	3707K-S06N-21R
Mating Type Part Number	ENTERY Non-Locking type: H112K-P06N-00B Locking type: H112K-P06N-03B

7.2.1 LED Pin assignment

Pin#	Signal Name
1	IRLED1 (current out)
2	IRLED2 (current out)
3	VLED (voltage in)
4	VLED (voltage in)
5	IRLED3 (current out)
6	IRLED4 (current out)

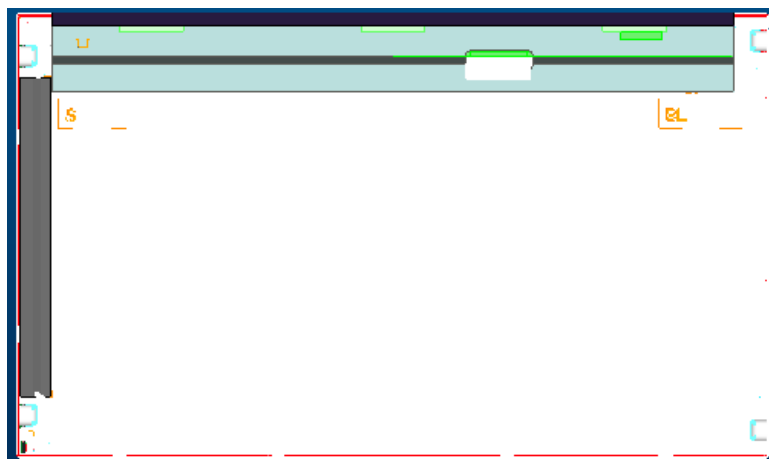
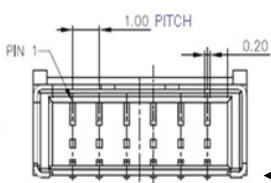

7.2.2 LED Connector dimension

$H \times V \times D = 13.9 \times 3.00 \times 4.25$, Pitch = 1.0 (unit = mm)

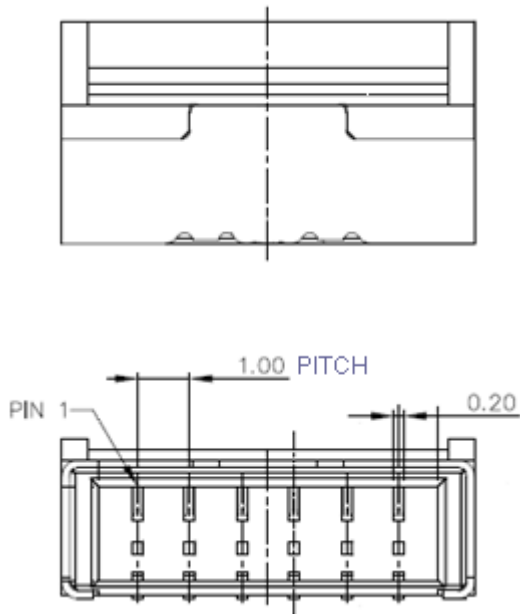

7.2.3 LED Mating housing dimension

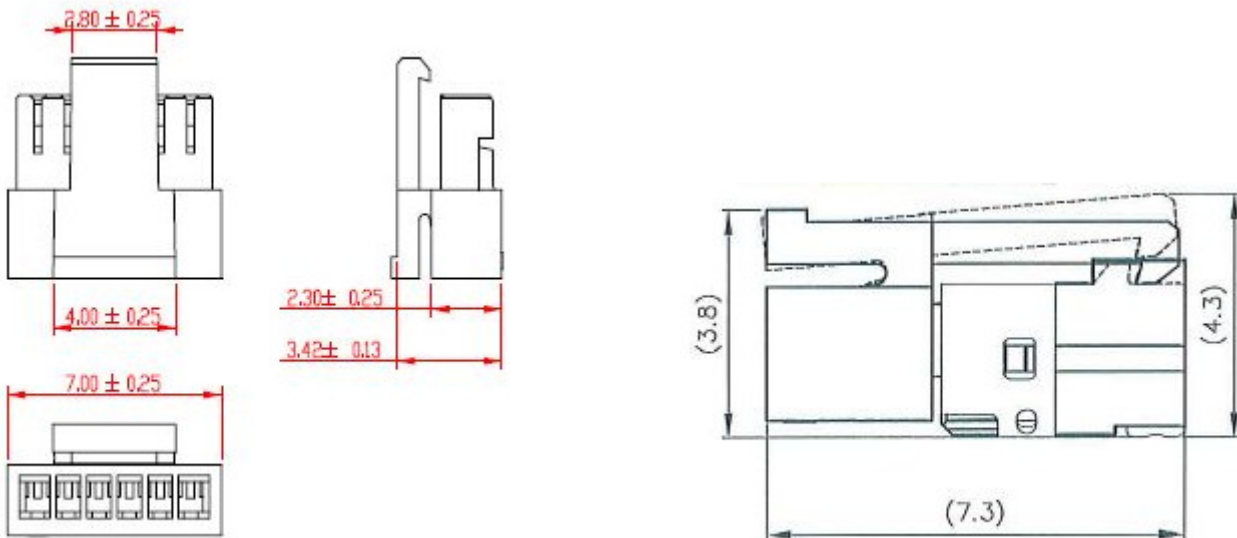

8 Reliability Test

Environment test conditions are listed as following table.

Items	Required Condition	Note
Temperature Humidity Bias (THB)	Ta= 50°C , 80%RH, 300hours	
High Temperature Operation (HTO)	Ta= 50°C , 50%RH, 300hours	
Low Temperature Operation (LTO)	Ta= 0°C , 300hours	
High Temperature Storage (HTS)	Ta= 60°C , 300hours	
Low Temperature Storage (LTS)	Ta= -20°C , 300hours	
Vibration Test (Non-operation)	Acceleration: 1.5 Grms Wave: Random Frequency: 10 - 200 Hz Sweep: 30 Minutes each Axis (X, Y, Z)	
Shock Test (Non-operation)	Acceleration: 50 G Wave: Half-sine Active Time: 20 ms Direction: ±X, ±Y, ±Z (one time for each Axis)	
Drop Test	Height: 60 cm, package test	
Thermal Shock Test (TST)	-20°C/30min, 60°C/30min, 100 cycles	1
On/Off Test	On/10sec, Off/10sec, 30,000 cycles	
ESD (Electro Static Discharge)	Contact Discharge: ± 15KV, 150pF(330Ω) 1sec, 8 points, 25 times/ point.	2
	Air Discharge: ± 15KV, 150pF(330Ω) 1sec 8 points, 25 times/ point.	
Altitude Test	Operation:18,000 ft Non-Operation:40,000 ft	

Note 1: The TFT-LCD module will not sustain damage after being subjected to 100 cycles of rapid temperature change. A cycle of rapid temperature change consists of varying the temperature from -20°C to 60°C, and back again. Power is not applied during the test. After temperature cycling, the unit is placed in normal room ambient for at least 4 hours before power on.

Note 2: EN61000-4-2, ESD class B: Certain performance degradation allowed

No data lost
Self-recoverable
No hardware failures.

9 Shipping Label

The label is on the panel as shown below:

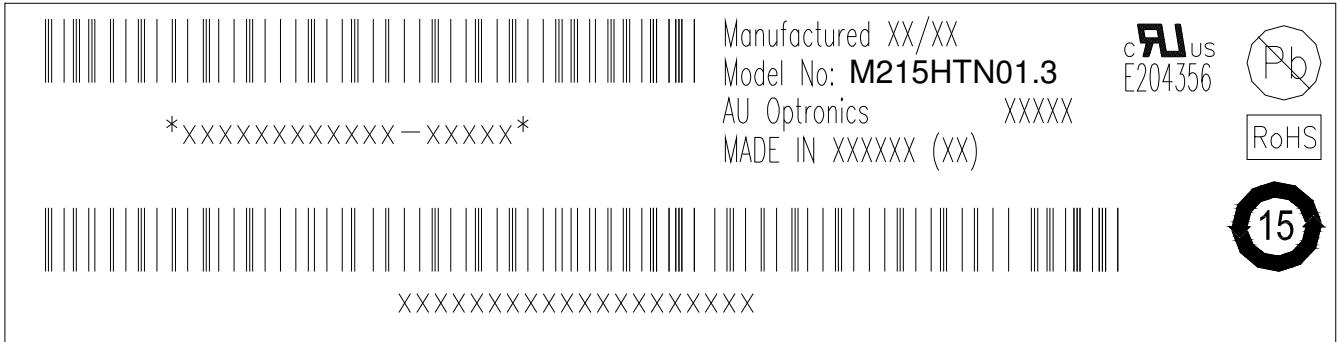

Note 1: For Pb Free products, AUO will add  for identification.

Note 2: For RoHS compatible products, AUO will add  for identification.

Note 3: For China RoHS compatible products, AUO will add  for identification.

Note 4: The Green Mark will be presented only when the green documents have been ready by AUO Internal Green Team.

10 Mechanical Characteristics

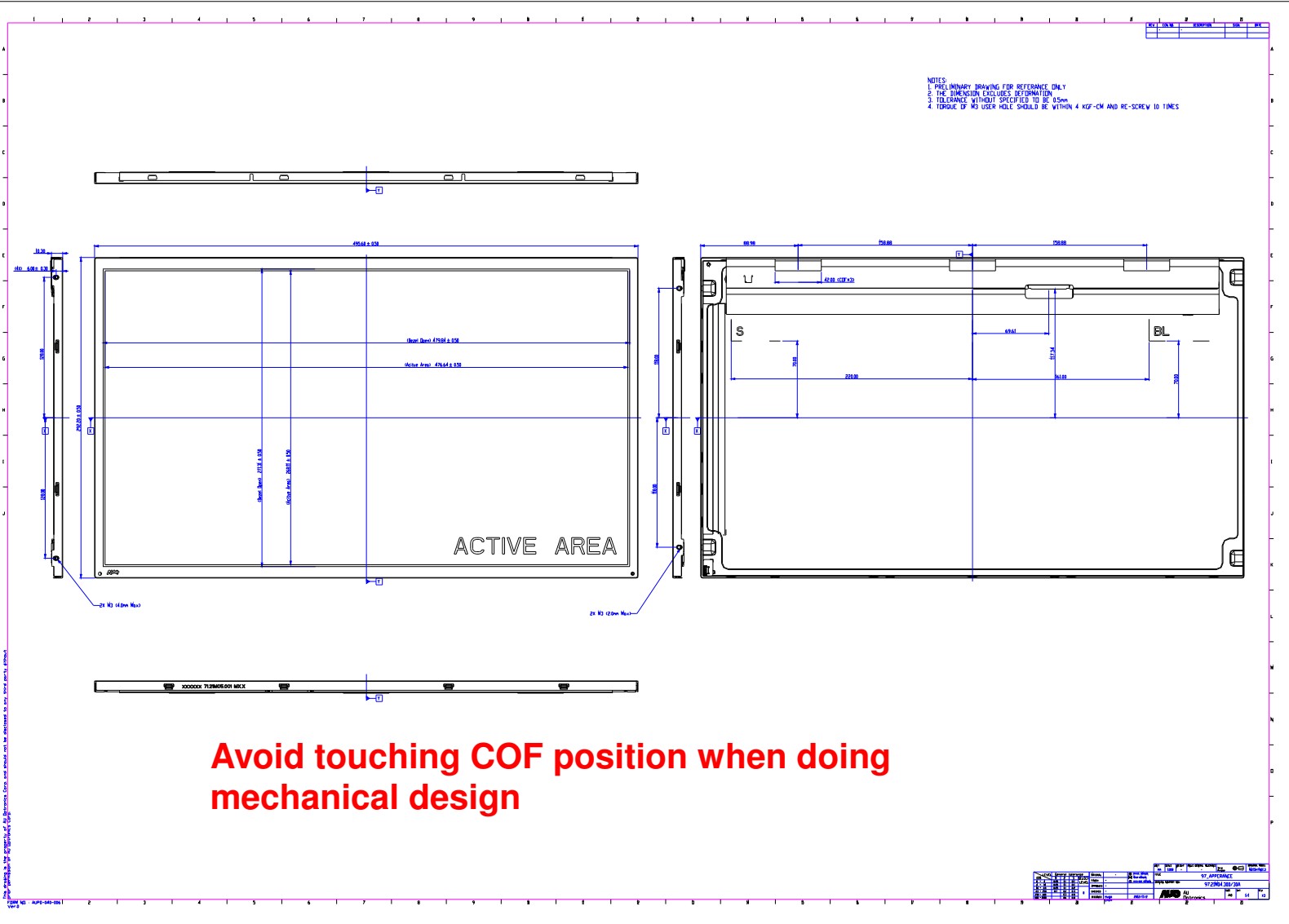

11. Packing Specification

11.1 Packing Flow

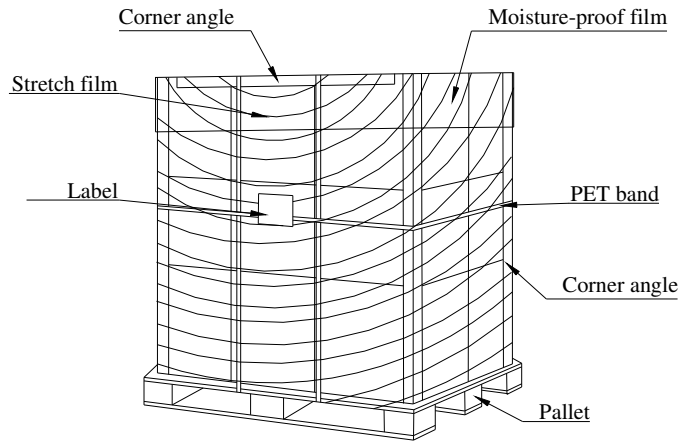
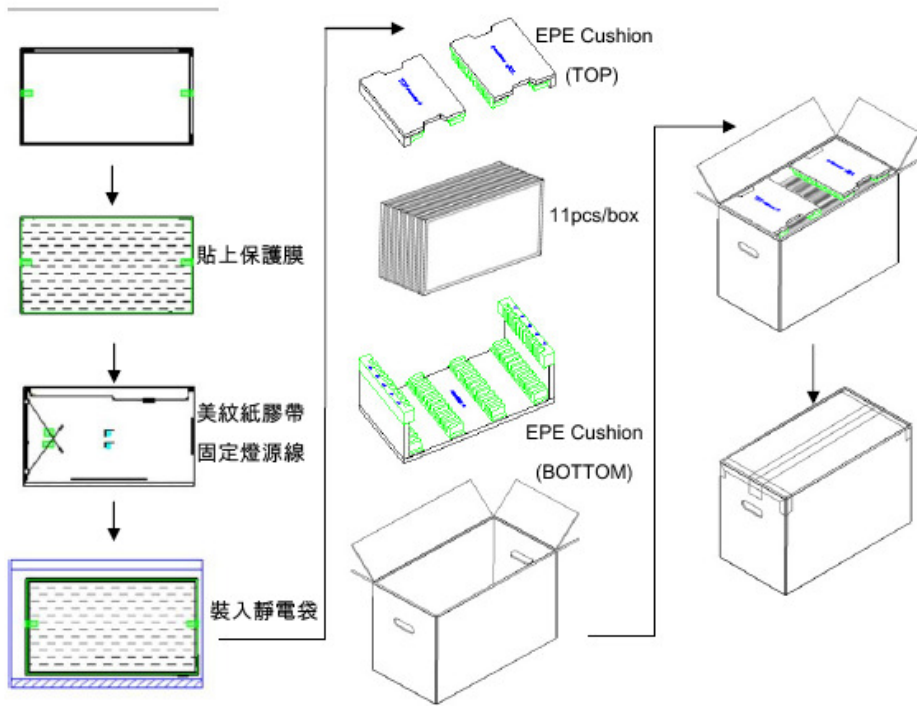

11. 2 Pallet and shipment information

	Item	Specification			Remark
		Q'ty	Dimension	Weight(kg)	
1	Panel	1	495.6(W)mm × 292.2(H)mm × 10.3(D)mm	1.75	
2	Cushion	1	-	0.40	
3	Box	1	556(L)mm x 292(W)mm x 375(H)mm	0.95	without Panel & cushion
4	Packing Box	11 pcs/Box	556(L)mm x 292(W)mm x 375(H)mm	20.6	with panel & cushion
5	Pallet	1	1150(L)mm x 910(W)mm x 132(H)mm	12.00	
6	Pallet after Packing	18 boxes/pallet	1150(L)mm x 910(W)mm x 1257(H)mm	382.8	