

( V ) Preliminary Specification

( ) Final Specification

Module	21.5" Color TFT-LCD
Model Name	M215HVN01.1

Customer	Date
_____	_____
Approved by 	_____
Note: This Specification is subject to change without notice.	

Approved by	Date
<u>Howard Lee</u>	<u>Jan 31, 2013</u>
Prepared by	Date
<u>Alan CH Liu</u>	<u>Jan 31, 2013</u>
AU Optronics corporation	

## Contents

<b>1 Handling Precautions</b> .....	<b>4</b>
<b>2 General Description</b> .....	<b>5</b>
2.1 Display Characteristics.....	5
2.2 Absolute Maximum Rating of Environment .....	6
2.3 Optical Characteristics .....	7
2.4 Mechanical Characteristics (For TPV ONLY).....	11
<b>3 TFT-LCD Module</b> .....	<b>12</b>
3.1 Block Diagram.....	12
3.2 Interface Connection.....	13
3.2.1 Connector Type.....	13
3.2.2 Connector Pin Assignment.....	13
3.3 Electrical Characteristics.....	15
3.3.1 Absolute Maximum Rating .....	15
3.3.2 Recommended Operating Condition.....	15
3.4 Signal Characteristics .....	16
3.4.1 LCD Pixel Format.....	16
3.4.2 LVDS Data Format.....	16
3.4.3 Color versus Input Data .....	17
3.4.4 LVDS Specification.....	18
3.4.5 Input Timing Specification.....	20
3.4.6 Input Timing Diagram.....	21
3.5 Power ON/OFF Sequence .....	21
<b>4 Backlight Unit</b> .....	<b>21</b>
4.1 Block Diagram.....	21
4.2 Interface Connection.....	21
4.2.1 Connector Type.....	21
4.2.2 Connector Pin Assignment.....	21
4.3 Electrical Characteristics.....	21
4.3.1 Absolute Maximum Rating .....	21
4.3.2 Recommended Operating Condition.....	21
<b>5 Reliability Test</b> .....	<b>21</b>
<b>6 Shipping Label</b> .....	<b>21</b>
<b>7 Mechanical Characteristics</b> .....	<b>21</b>
<b>8 Packing Specification</b> .....	<b>21</b>
8.1 Packing Flow.....	21
8.2 Pallet and shipment information.....	21

## Record of Revision

Version	Date	Page	Old description	New Description	Remark
0.1	2013/1/31	All	First version release	-	

SPLCD.com  
Supply & Purchase Cloud Platform



## 1 Handling Precautions

- 1) Since front polarizer is easily damaged, pay attention not to scratch it.
- 2) Be sure to turn off power supply when inserting or disconnecting from input connector.
- 3) Wipe off water drop immediately. Long contact with water may cause discoloration or spots.
- 4) When the panel surface is soiled, wipe it with absorbent cotton or other soft cloth.
- 5) Since the panel is made of glass, it may break or crack if dropped or bumped on hard surface.
- 6) Since CMOS LSI is used in this module, take care of static electricity and insure human earth when handling.
- 7) Do not open or modify the Module Assembly.
- 8) Do not press the reflector sheet at the back of the module to any directions.
- 9) In case a TFT-LCD Module has to be put back into the packing container slot after once it was taken out from the container, do not press the center of the LED lightbar edge. Otherwise the TFT-LCD Module may be damaged.
- 10) Insert or pull out the interface connector, be sure not to rotate nor tilt it of the TFT-LCD Module.
- 11) Do not twist nor bend the TFT -LCD Module even momentary. It should be taken into consideration that no bending/twisting forces are applied to the TFT-LCD Module from outside. Otherwise the TFT-LCD Module may be damaged.
- 12) Please avoid touching COF position while you are doing mechanical design.
- 13) When storing modules as spares for a long time, the following precaution is necessary: Store them in a dark place. Do not expose the module to sunlight or fluorescent light. Keep the temperature between 5°C and 35°C at normal humidity.

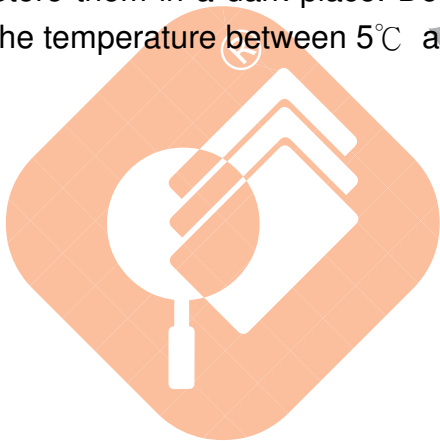

## 2 General Description

This specification applies to the 21.5 inch wide Color a-Si TFT-LCD Module M215HVN01.1. The display supports the Full HD - 1920(H) x 1080(V) screen format and 16.7M colors (RGB 8-bit). The input interface is Dual channel LVDS and this module doesn't contain an driver board for backlight.

### 2.1 Display Characteristics

The following items are characteristics summary on the table under 25°C condition:

ITEMS	Unit	SPECIFICATIONS
Screen Diagonal	[mm]	546.86 (21.53")
Active Area	[mm]	476.64 (H) x 268.11 (V)
Pixels H x V	-	1920(x3) x 1080
Pixel Pitch	[um]	248.25 (per one triad) x248.25
Pixel Arrangement	-	R.G.B. Vertical Stripe
Display Mode	-	VA Mode, Normally Black
White Luminance ( Center )	[cd/m <sup>2</sup> ]	250 (Typ.)
Contrast Ratio	-	3000 (Typ.)
Response Time	[msec]	12 (Typ., on/off)
Power Consumption (LCD Module + Backligh unit)	[Watt]	16.55 watt (Typ.) (VDD line : PDD (typ), All white pattern at 60Hz = 3.45W LED line : PBLU (typ) = 13.1W)
Weight	[Grams]	1800
Outline Dimension	[mm]	495.6(H) x 292.2(V) x 10.6 (D) Typ.
Electrical Interface	-	Dual channel LVDS
Support Color	-	16.7M colors (RGB 8-bit )
Surface Treatment	-	Anti-Glare, 3H
Temperature Range		
Operating	[°C]	0 to +50
Storage (Shipping)	[°C]	-20 to +60
RoHS Compliance	-	RoHS Compliance
TCO Compliance	-	TCO 6.0 Compliance

## 2.2 Absolute Maximum Rating of Environment

Permanent damage may occur if exceeding the following maximum rating.

Symbol	Description	Min.	Max.	Unit	Remark
TOP	Operating Temperature	0	+50	[°C]	<b>Note 2-1</b>
TGS	Glass surface temperature (operation)	0	+65	[°C]	<b>Note 2-1</b> Function judged only
HOP	Operation Humidity	5	90	[%RH]	<b>Note 2-1</b>
TST	Storage Temperature	-20	+60	[°C]	
HST	Storage Humidity	5	90	[%RH]	

**Note 2-1:** Temperature and relative humidity range are shown as the below figure.

1. 90% RH Max (  $T_a \leq 39^\circ\text{C}$  )
2. Max wet-bulb temperature at  $39^\circ\text{C}$  or less. (  $T_a \leq 39^\circ\text{C}$  )
3. No condensation

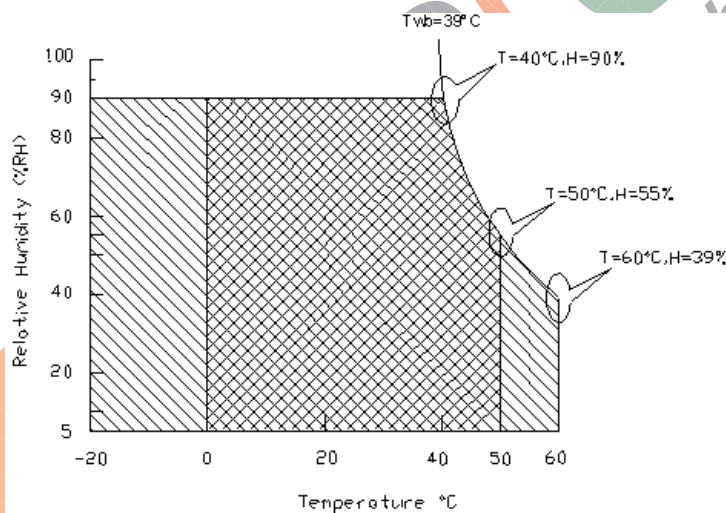

Operating Range



Storage Range

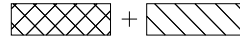

## 2.3 Optical Characteristics

The optical characteristics are measured on the following test condition.

### Test Condition:

1. Equipment setup: Please refer to **Note 2-2**.
2. Panel Lighting time: 30 minutes
3. VDD=5.0V, Fv=60Hz, Is=65mA, Ta=25°C

Symbol	Description		Min.	Typ.	Max	Unit	Remark
L <sub>w</sub>	White Luminance (Center of screen)		200	250	-	[cd/m <sup>2</sup> ]	<b>Note 2-2</b> By SR-3
L <sub>uni</sub>	Luminance Uniformity (9 points)		75	80	-	[%]	<b>Note 2-3</b> By SR-3
CR	Contrast Ratio (Center of screen)		2000	3000	-	-	<b>Note 2-4</b> By SR-3
θ <sub>R</sub>	Horizontal Viewing Angle (CR=10)	Right	75	89	-	[degree]	<b>Note 2-5</b> By SR-3
θ <sub>L</sub>		Left	75	89	-		
Φ <sub>H</sub>	Vertical Viewing Angle (CR=10)	Up	75	89	-		
Φ <sub>L</sub>		Down	75	89	-		
θ <sub>R</sub>	Horizontal Viewing Angle (CR=5)	Right	75	89	-		
θ <sub>L</sub>		Left	75	89	-		
Φ <sub>H</sub>	Vertical Viewing Angle (CR=5)	Up	75	89	-		
Φ <sub>L</sub>		Down	75	89	-		
T <sub>R</sub>	Response Time	Rising Time	-	7	-	[msec]	<b>Note 2-6</b> By TRD-100
T <sub>F</sub>		Falling Time	-	5	-		
-		Rising + Falling	-	12	-		
R <sub>x</sub>	Color Coordinates (CIE 1931)	Red x	0.617	0.647	0.677	-	By SR-3
R <sub>y</sub>		Red y	0.305	0.335	0.365		
G <sub>x</sub>		Green x	0.290	0.320	0.350		
G <sub>y</sub>		Green y	0.593	0.623	0.653		
B <sub>x</sub>		Blue x	0.119	0.149	0.179		
B <sub>y</sub>		Blue y	0.020	0.050	0.080		
W <sub>x</sub>		White x	0.283	0.313	0.343		
W <sub>y</sub>		White y	0.299	0.329	0.359		
CT	Crosstalk		-	-	1.5	[%]	<b>Note 2-7</b> By SR-3
F <sub>dB</sub>	Flicker (Center of screen)		-	-	-20	[dB]	<b>Note 2-8</b> By SR-3



**Note 2-2:** Equipment setup :

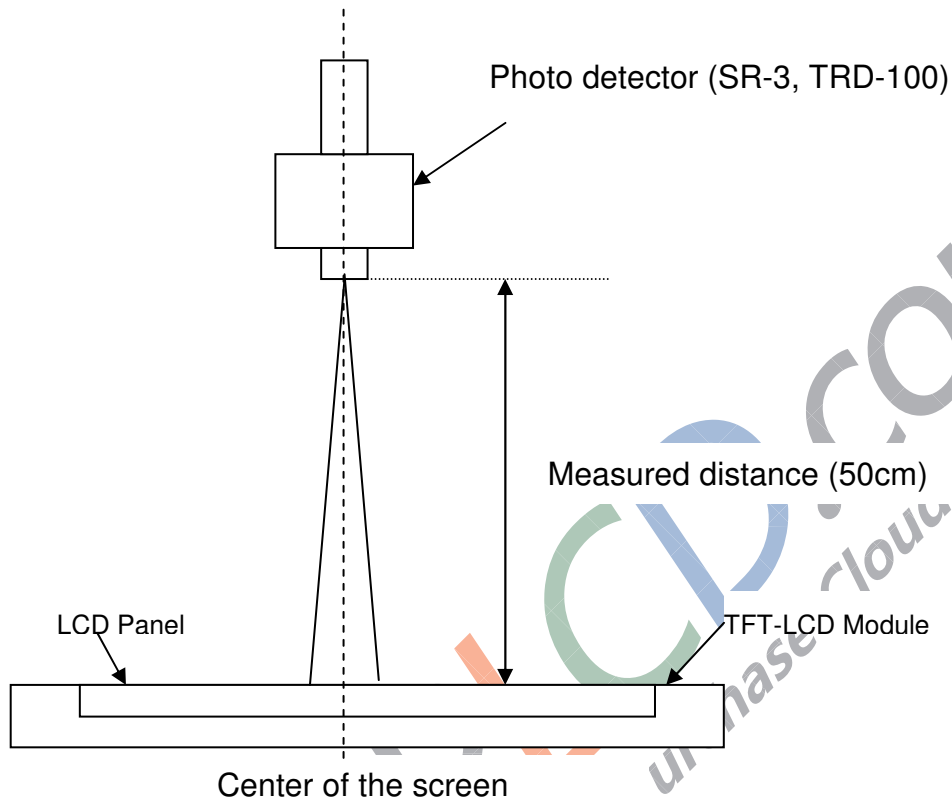

**Note 2-3:** Luminance Uniformity Measurement

**Definition:**

$$\text{Luminance Uniformity} = \frac{\text{Minimum Luminance of 9 Points (P1 ~ P9)}}{\text{Maximum Luminance of 9 Points (P1 ~ P9)}}$$

*a. Test pattern: White Pattern*

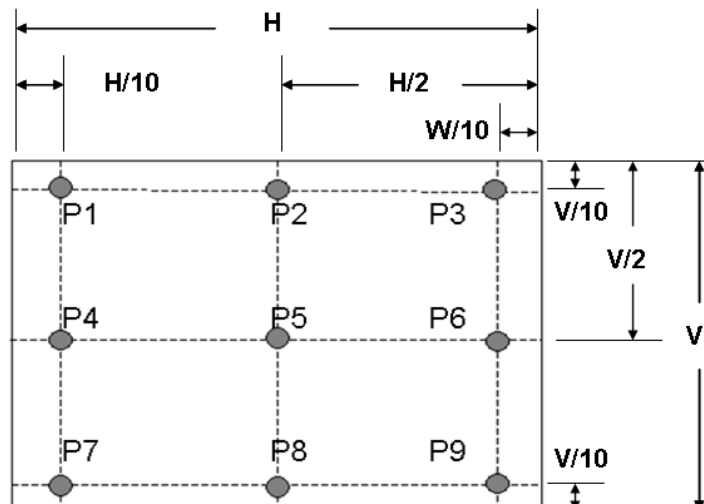



**Note 2-4:** Contrast Ratio Measurement

**Definition:**

$$\text{Contrast Ratio} = \frac{\text{Luminance of White pattern}}{\text{Luminance of Black pattern}}$$

- a. Measured position: Center of screen (P5) & perpendicular to the screen ( $\theta = \Phi = 0^\circ$ )

**Note 2-5:** Viewing angle measurement

**Definition:** The angle at which the contrast ratio is greater than 10 & 5.

- a. Horizontal view angle: Divide to left & right ( $\theta_L$  &  $\theta_R$ )  
Vertical view angle: Divide to up & down ( $\Phi_H$  &  $\Phi_L$ )

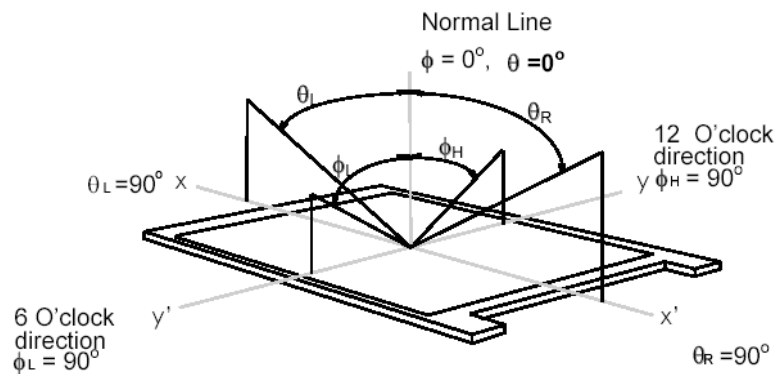

**Note 2-6:** Response time measurement

The output signals of photo detector are measured when the input signals are changed from “Black” to “White” (rising time,  $T_R$ ), and from “White” to “Black” (falling time,  $T_F$ ), respectively. The response time is interval between the 10% and 90% of optical response. (*Black & White color definition: Please refer section 3.4.3*)

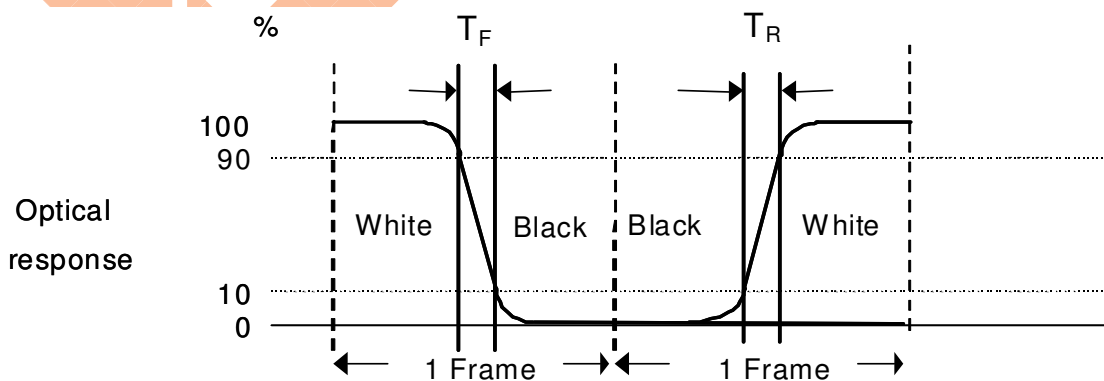

**Note 2-7: Crosstalk measurement**

**Definition:**

$$CT = \text{Max. } (CT_H, CT_V);$$

Where

a. Maximum Horizontal Crosstalk :

$$CT_H = \text{Max. } (| Y_{BL} - Y_{AL} | / Y_{AL} \times 100 \%, | Y_{BR} - Y_{AR} | / Y_{AR} \times 100 \%);$$

Maximum Vertical Crosstalk:

$$CT_V = \text{Max. } (| Y_{BU} - Y_{AU} | / Y_{AU} \times 100 \%, | Y_{BD} - Y_{AD} | / Y_{AD} \times 100 \%);$$

b.  $Y_{AU}, Y_{AD}, Y_{AL}, Y_{AR}$  = Luminance of measured location without Black pattern

$Y_{BU}, Y_{BD}, Y_{BL}, Y_{BR}$  = Luminance of measured location with Black pattern

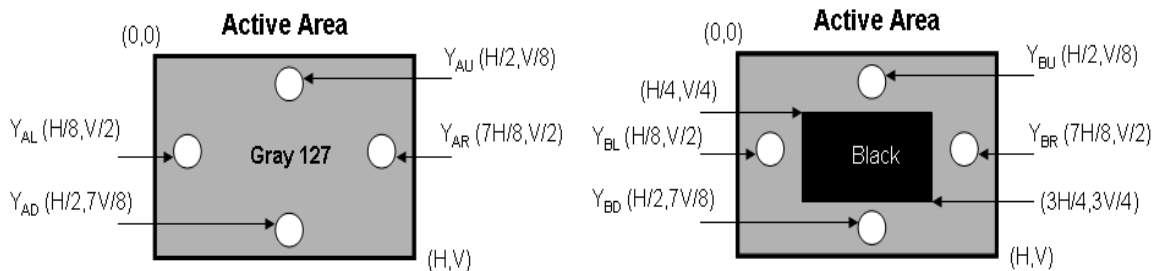

**Note 2-8: Flicker measurement**

a. Test pattern: It is listed as following.

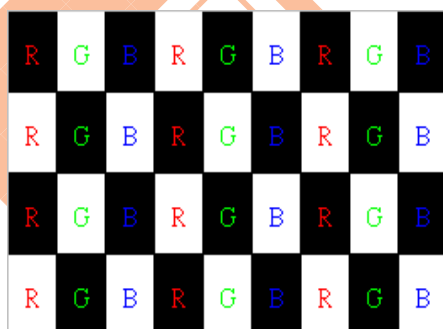

Gray level = L0



Gray level = L127

R: Red, G: Green, B:Blue

b. Measured position: Center of screen (P5) & perpendicular to the screen ( $\theta = \Phi = 0^\circ$ )

## 2.4 Mechanical Characteristics

Symbol	Description	Min.	Max.	Unit	Remark
P <sub>bc</sub>	Backside Compression	2.5	-	[Kgf]	<b>Note 2-9</b>

**Note 2-9:** Test Method:

The point is at a distance from right-downside 25mm x 25mm defined as the Start Point of Measure Points, and the point is at a distance 25mm from left-side & around 10mm from PCB defined as the End Point.

Align 50mm x 50mm block from Start Point on the Bezel Back, and the corners of each block are Measure Points.

If the distance from the last block to each side of the End Point  $\geq 25$ mm, add other blocks to make sure that most area of Bezel Back can be measured.

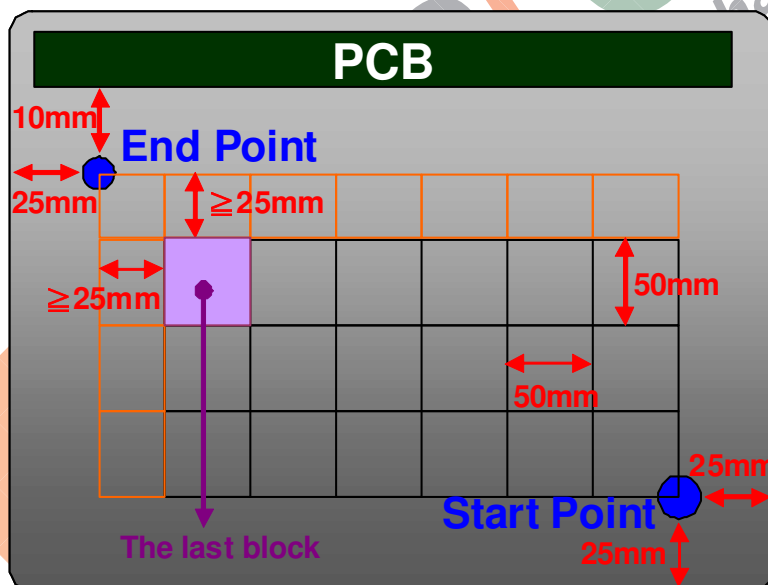

## 3 TFT-LCD Module

### 3.1 Block Diagram

The following shows the block diagram of the 21.5 inch Color TFT-LCD Module.

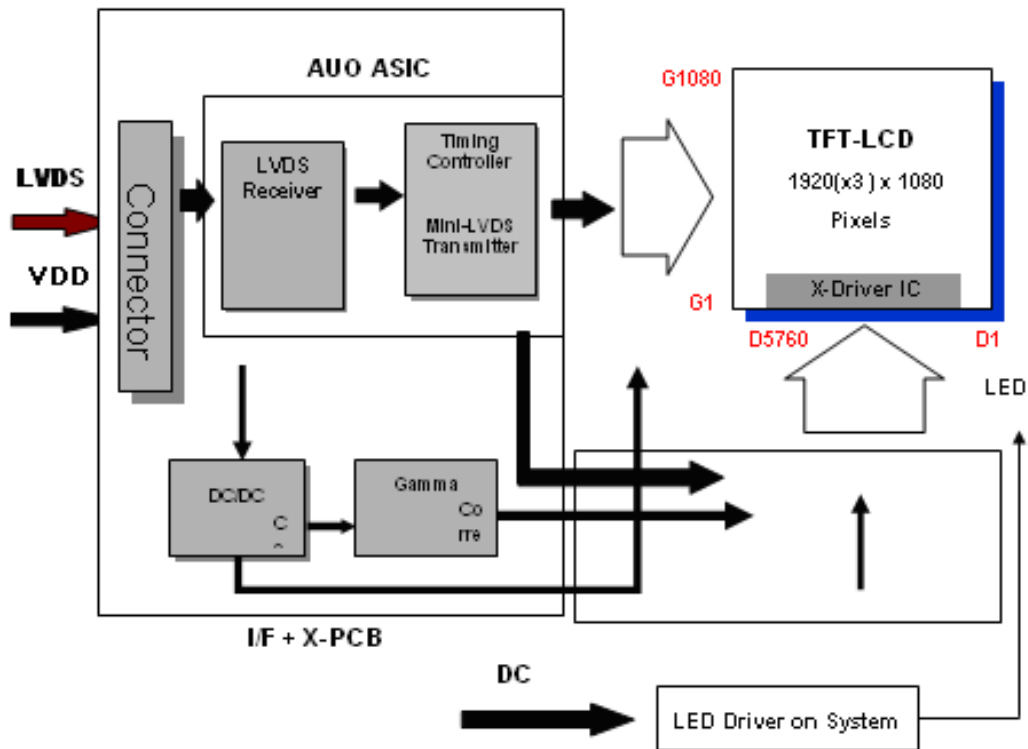

## 3.2 Interface Connection

### 3.2.1 Connector Type

TFT-LCD Connector	Manufacturer	STM	P-TWO
	Part Number	MSCKT2407P30HB	AL230F-A0G1D-P
Mating Connector	Manufacturer	JAE	
	Part Number	FI-X30HL (Locked Type)	

### 3.2.2 Connector Pin Assignment

PIN #	Symbol	Description	Remark
1	RxO0-	Negative LVDS differential data input (Odd data)	
2	RxO0+	Positive LVDS differential data input (Odd data)	
3	RxO1-	Negative LVDS differential data input (Odd data)	
4	RxO1+	Positive LVDS differential data input (Odd data)	
5	RxO2-	Negative LVDS differential data input (Odd data)	
6	RxO2+	Positive LVDS differential data input (Odd data)	
7	GND	Ground	
8	RxOCLK-	Negative LVDS differential clock input (Odd clock)	
9	RxOCLK+	Positive LVDS differential clock input (Odd clock)	
10	RxO3-	Negative LVDS differential data input (Odd data)	
11	RxO3+	Positive LVDS differential data input (Odd data)	
12	RxE0-	Negative LVDS differential data input (Even data)	
13	RxE0+	Positive LVDS differential data input (Even data)	
14	GND	Ground	
15	RxE1-	Negative LVDS differential data input (Even data)	
16	RxE1+	Positive LVDS differential data input (Even data)	
17	GND	Ground	
18	RxE2-	Negative LVDS differential data input (Even data)	
19	RxE2+	Positive LVDS differential data input (Even data)	
20	RxECLK-	Negative LVDS differential clock input (Even clock)	
21	RxECLK+	Positive LVDS differential clock input (Even clock)	
22	RxE3-	Negative LVDS differential data input (Even data)	
23	RxE3+	Positive LVDS differential data input (Even data)	
24	GND	Ground	
25	NC	No connection (for AUO test only. Do not connect)	
26	NC	No connection (for AUO test only. Do not connect)	

27	NC	No connection (for AUO test only. Do not connect)	
28	VDD	Power Supply Input Voltage	
29	VDD	Power Supply Input Voltage	
30	VDD	Power Supply Input Voltage	

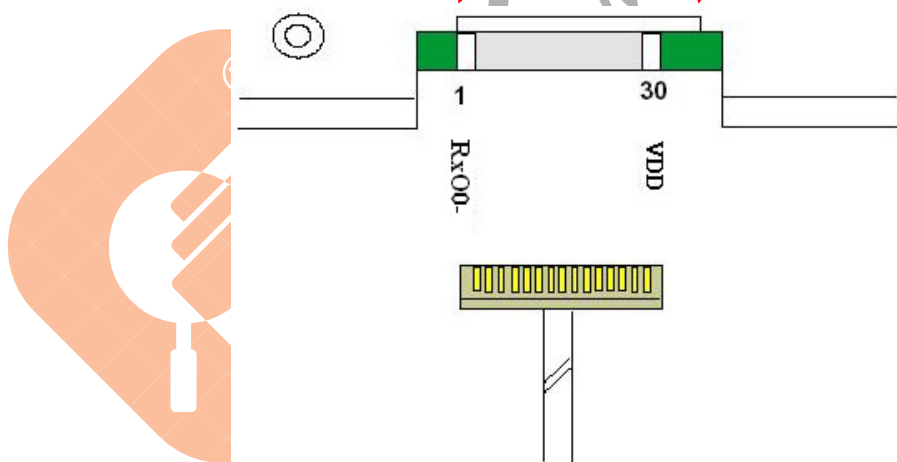
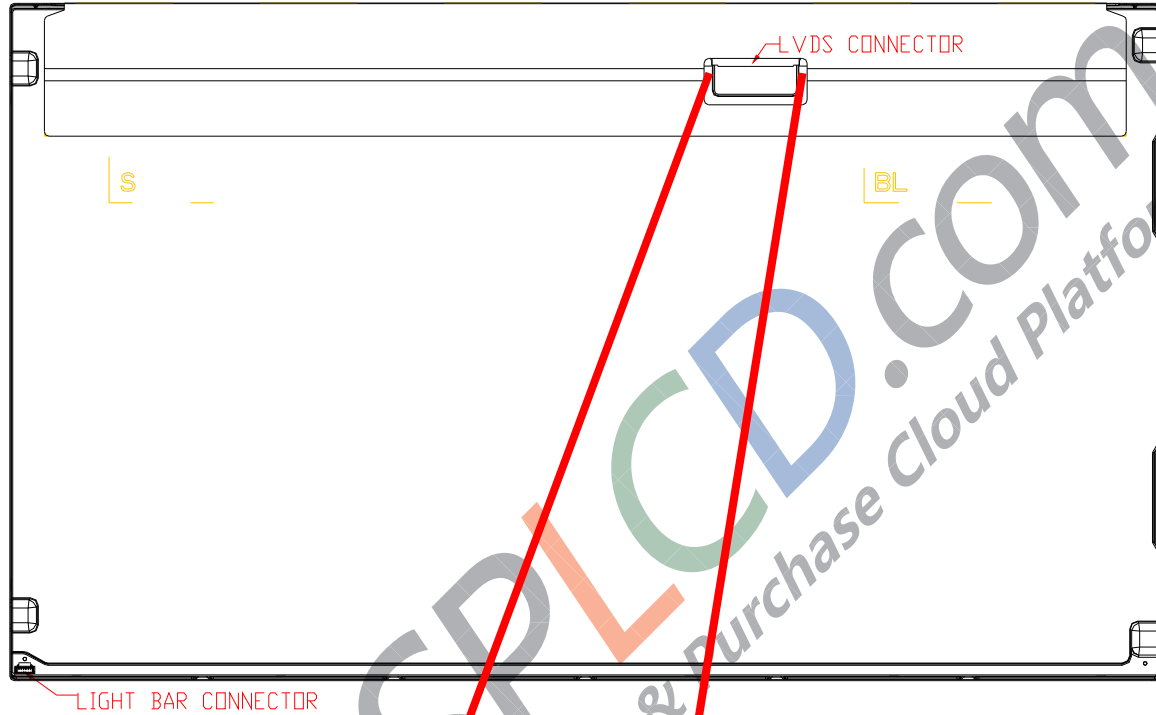

## 3.3 Electrical Characteristics

### 3.3.1 Absolute Maximum Rating

Permanent damage may occur if exceeding the following maximum rating.

Symbol	Description	Min	Max	Unit	Remark
VDD	Power Supply Input Voltage	GND-0.3	6.0	[Volt]	Ta=25°C

### 3.3.2 Recommended Operating Condition

Symbol	Description	Min	Typ	Max	Unit	Remark
VDD	Power supply Input voltage	4.5	5.0	5.5	[Volt]	
IDD	Power supply Input Current (RMS)	-	0.69	0.83	[A]	VDD= 5.0V, Black Pattern, Fv=60Hz
		-	0.8	0.96	[A]	VDD= 5.0V, Black Pattern, Fv=75Hz
PDD	VDD Power Consumption	-	3.45	4.15	[Watt]	VDD= 5.0V, Black Pattern, Fv=60Hz
		-	4	4.8	[Watt]	VDD= 5.0V, Black Pattern, Fv=75Hz
IRush	Inrush Current	-	-	3.0	[A]	<b>Note 3-1</b>
VDDrp	Allowable VDD Ripple Voltage	-	-	500	[mV]	VDD= 5.0V, Black Pattern, Fv=75Hz

**Note 3-1:** Inrush Current measurement:

Test circuit:

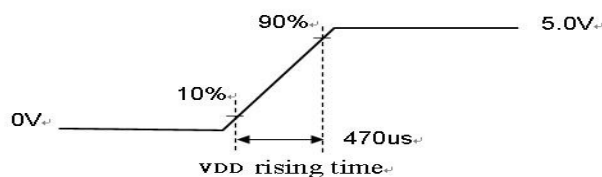
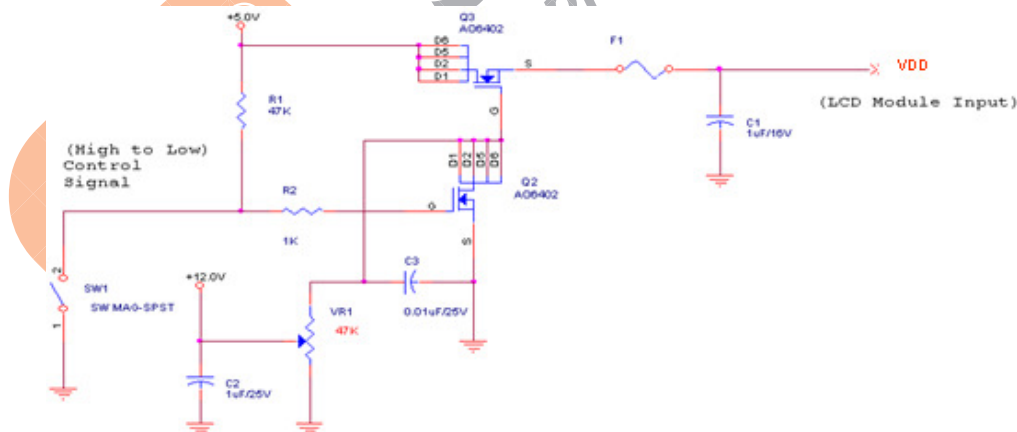

The duration of VDD rising time: 470us.



## 3.4 Signal Characteristics

### 3.4.1 LCD Pixel Format

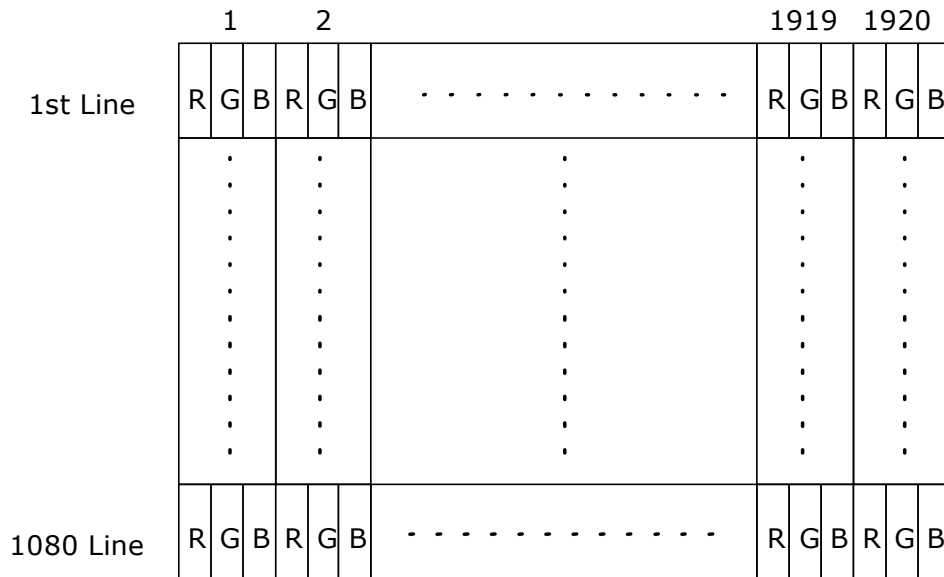

### 3.4.2 LVDS Data Format

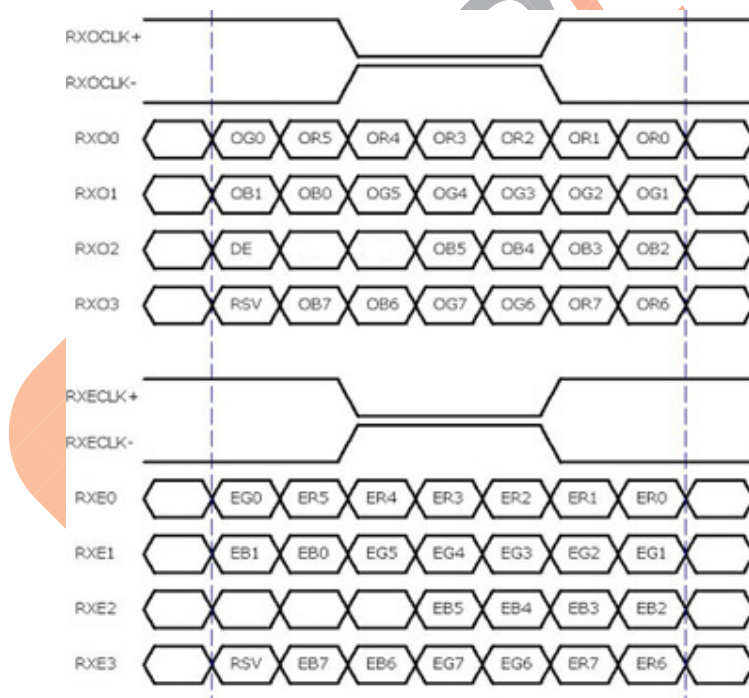

8 Bit Color Bit Order			
<b>MSB</b>	R7	G7	B7
	R6	G6	B6
	R5	G5	B5
	R4	G4	B4
	R3	G3	B3
	R2	G2	B2
	R1	G1	B1
<b>LSB</b>	R0	G0	B0

**Note 3-2:**

- a. O = "Odd Pixel Data"    E = "Even Pixel Data"
- b. Refer to 3.4.1 LCD pixel format, the 1st data is 1 (Odd Pixel Data), the 2<sup>nd</sup> data is 2 (Even Pixel Data) and the last data is 1920 (Even Pixel Data).

### 3.4.3 Color versus Input Data

The following table is for color versus input data (8bit). The higher the gray level, the brighter the color.

Color	Gray Level	Color Input Data																								Remark
		RED data (MSB:R7, LSB:R0)								GREEN data (MSB:G7, LSB:G0)								BLUE data (MSB:B7, LSB:B0)								
		R7	R6	R5	R4	R3	R2	R1	R0	G7	G6	G5	G4	G3	G2	G1	G0	B7	B6	B5	B4	B3	B2	B1	B0	
Black	-	0	0	0	0	0	0	0	0	0	0	0	0	0	0	0	0	0	0	0	0	0	0	0	0	
White	-	1	1	1	1	1	1	1	1	1	1	1	1	1	1	1	1	1	1	1	1	1	1	1	1	
Gray 127	-	0	1	1	1	1	1	1	1	0	1	1	1	1	1	1	1	0	1	1	1	1	1	1	1	
Red	L0	0	0	0	0	0	0	0	0	0	0	0	0	0	0	0	0	0	0	0	0	0	0	0	0	Black
	:	:	:	:	:	:	:	:	:	:	:	:	:	:	:	:	:	:	:	:	:	:	:	:	:	
	L255	1	1	1	1	1	1	1	1	0	0	0	0	0	0	0	0	0	0	0	0	0	0	0	0	
Green	L0	0	0	0	0	0	0	0	0	0	0	0	0	0	0	0	0	0	0	0	0	0	0	0	0	Black
	:	:	:	:	:	:	:	:	:	:	:	:	:	:	:	:	:	:	:	:	:	:	:	:	:	
	L255	0	0	0	0	0	0	0	0	1	1	1	1	1	1	1	1	0	0	0	0	0	0	0	0	
Blue	L0	0	0	0	0	0	0	0	0	0	0	0	0	0	0	0	0	0	0	0	0	0	0	0	0	Black
	:	:	:	:	:	:	:	:	:	:	:	:	:	:	:	:	:	:	:	:	:	:	:	:	:	
	L255	0	0	0	0	0	0	0	0	0	0	0	0	0	0	0	0	1	1	1	1	1	1	1	1	



### 3.4.4 LVDS Specification

#### a. DC Characteristics:

Symbol	Description	Min	Typ	Max	Units	Condition
$V_{TH}$	LVDS Differential Input High Threshold	-	-	+100	[mV]	$V_{CM} = 1.2V$
$V_{TL}$	LVDS Differential Input Low Threshold	-100	-	-	[mV]	$V_{CM} = 1.2V$
$ V_{ID} $	LVDS Differential Input Voltage	100	-	600	[mV]	
$V_{CM}$	LVDS Common Mode Voltage	+1.0	+1.2	+1.5	[V]	$V_{TH} - V_{TL} = 200mV$

#### LVDS Signal Waveform:

Use RxOCLK- & RxOCLK+ as example.

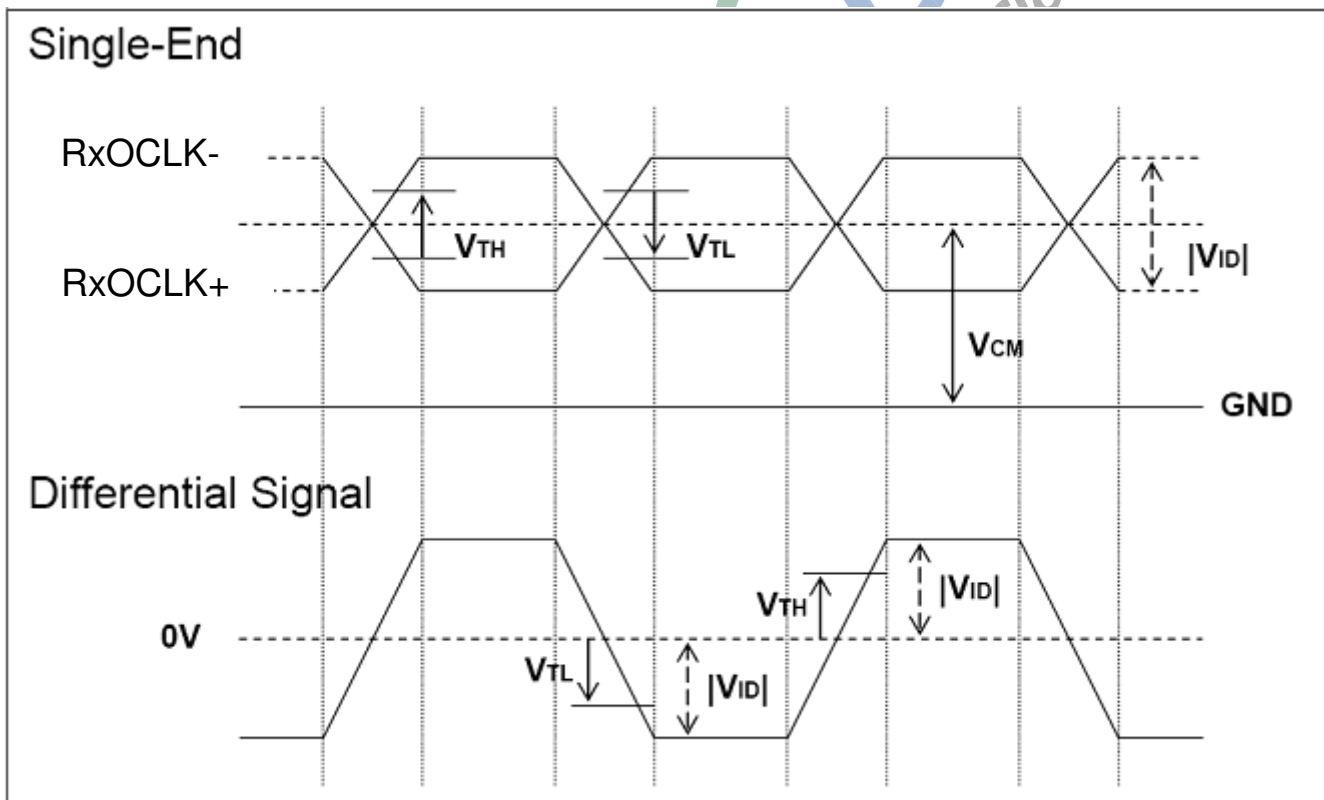

## b. AC Characteristics:

Symbol	Description	Min	Max	Unit	Remark
$F_{DEV}$	Maximum deviation of input clock frequency during Spread Spectrum	-	$\pm 3$	%	
$F_{MOD}$	Maximum modulation frequency of input clock during Spread Spectrum	-	200	KHz	

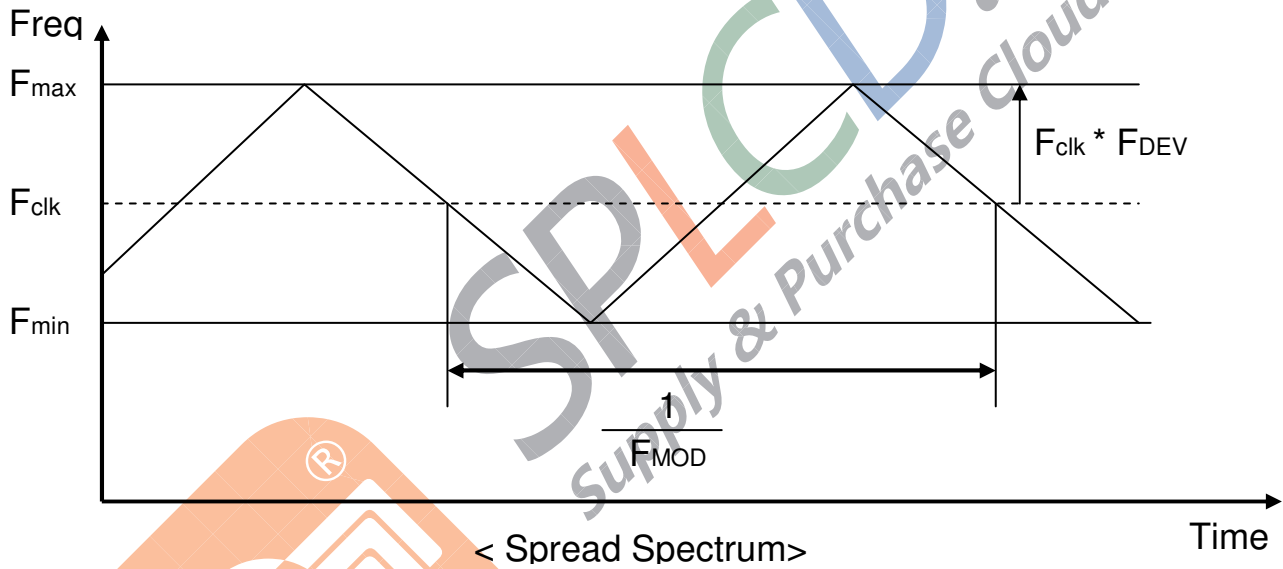

Fclk: LVDS Clock Frequency

### 3.4.5 Input Timing Specification

It only support DE mode, and the input timing are shown as the following table.

Symbol	Description		Min.	Typ.	Max.	Unit	Remark
Tv	Vertical Section	Period	1092	1130	1793	Th	
Tdisp (v)		Active	1080	1080	1080	Th	
Tblk (v)		Blanking	12	50	713	Th	
Fv		Frequency	50	60	76	Hz	
Th	Horizontal Section	Period	1004	1050	1100	Tclk	
Tdisp (h)		Active	960	960	960	Tclk	
Tblk (h)		Blanking	44	90	140	Tclk	
Fh		Frequency	55	68	90	KHz	<b>Note 3-3</b>
Tclk	LVDS Clock	Period	11.1	14	18.2	ns	1/Fclk
Fclk		Frequency	54.8	71.2	90	MHz	<b>Note 3-4</b>

**Note 3-3:** The equation is listed as following. Please don't exceed the above recommended value.

$$Fh (\text{Min.}) = Fclk (\text{Min.}) / Th (\text{Min.});$$

$$Fh (\text{Typ.}) = Fclk (\text{Typ.}) / Th (\text{Typ.});$$

$$Fh (\text{Max.}) = Fclk (\text{Max.}) / Th (\text{Min.});$$

**Note 3-4:** The equation is listed as following. Please don't exceed the above recommended value.

$$Fclk (\text{Min.}) = Fv (\text{Min.}) \times Th (\text{Min.}) \times Tv (\text{Min.});$$

$$Fclk (\text{Typ.}) = Fv (\text{Typ.}) \times Th (\text{Typ.}) \times Tv (\text{Typ.});$$

$$Fclk (\text{Max.}) = Fv (\text{Max.}) \times Th (\text{Typ.}) \times Tv (\text{Typ.});$$

## 3.4.6 Input Timing Diagram

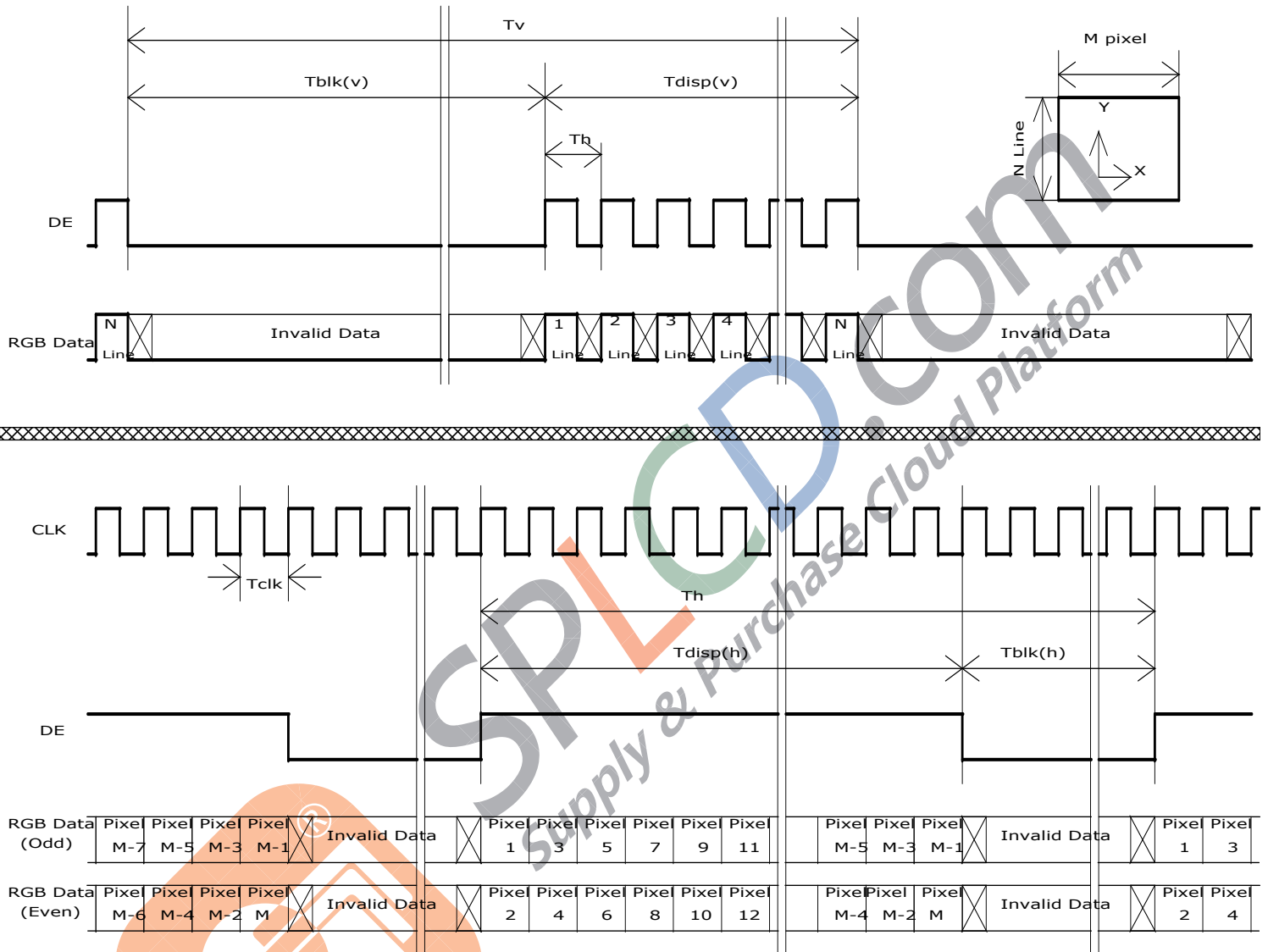

### 3.5 Power ON/OFF Sequence

VDD power, LVDS signal and backlight on/off sequence are as following. LVDS signals from any system shall be Hi-Z state when VDD is off.

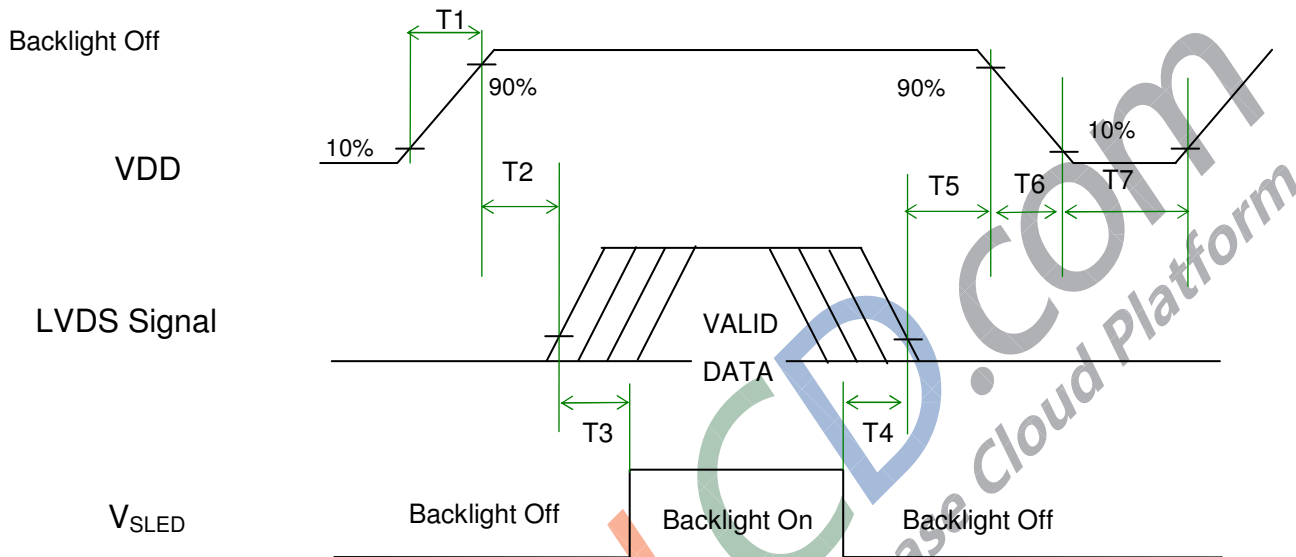

**Power Sequence Timing**

Symbol	Value			Unit	Remark
	Min.	Typ.	Max.		
T1	0.5	-	10	[ms]	
T2	0	-	50	[ms]	
T3	500	-	-	[ms]	
T4	100	-	-	[ms]	
T5	0	-	50	[ms]	<b>Note 3-5</b> <b>Note 3-6</b>
T6	0	-	150	[ms]	<b>Note 3-6</b>
T7	1000	-	-	[ms]	

**Note 3-5 :** Recommend setting T5 = 0ms to avoid electronic noise when VDD is off.

**Note 3-6 :** During T5 and T6 period , please keep the level of input LVDS signals with Hi-Z state.



## 4 Backlight Unit

### 4.1 Block Diagram

The following shows the block diagram of the 21.5 inch Backlight Unit. And it includes 68 pcs LED in the LED light bar. (4 strings and 17 pcs LED of one string).

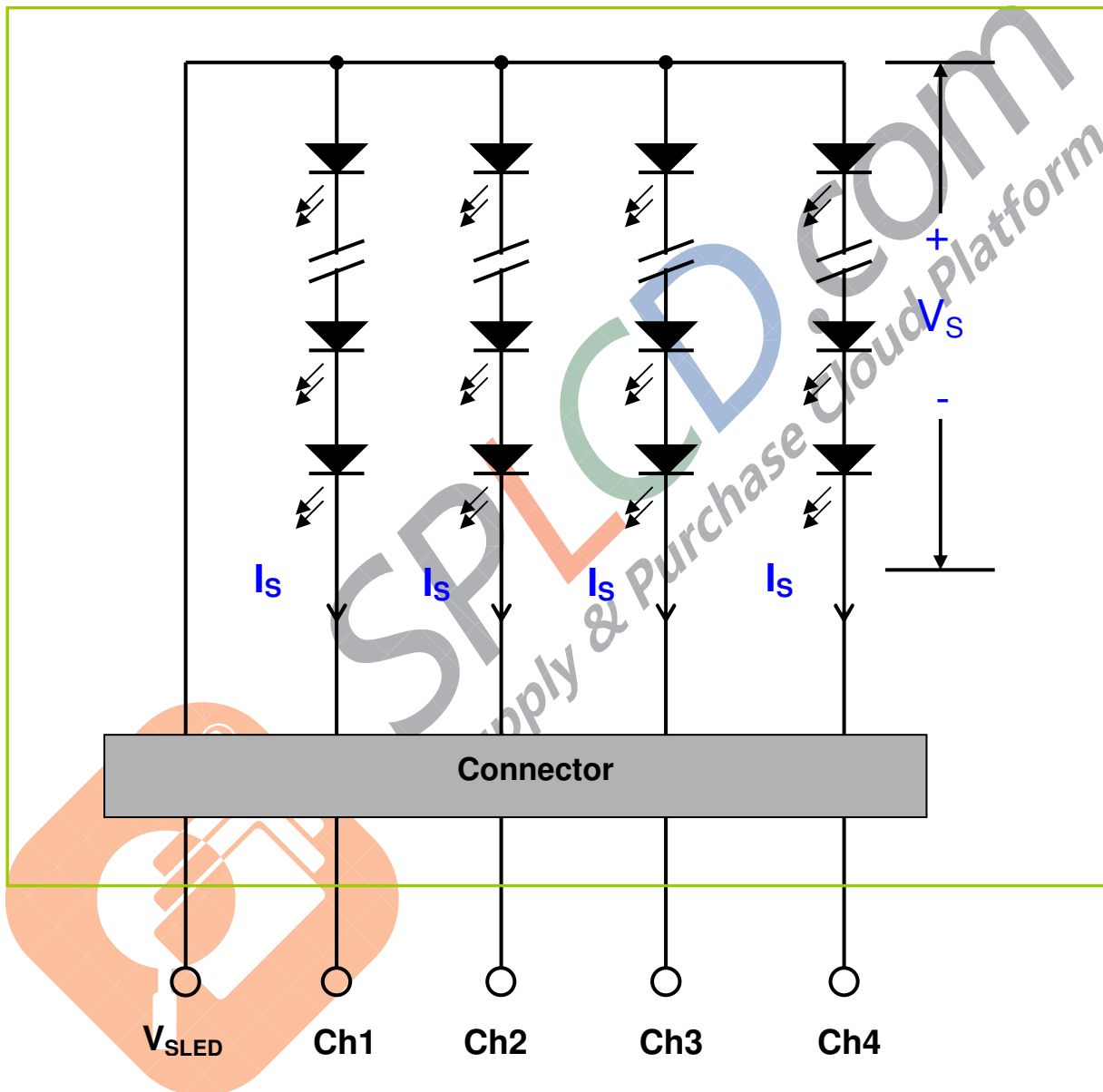

## 4.2 Interface Connection

### 4.2.1 Connector Type

Backlight Connector	Manufacturer	ENTERY
	Part Number	3707K-S06N-21R
Mating Connector	Manufacturer	ENTERY
	Part Number	H112K-P06N-00B (Non-Locking type) H112K-P06N-03B (Locking type)

### Backlight Connector dimension:

$H \times V \times D = 13.9 \times 3.00 \times 4.25$ , Pitch = 1.0 (unit = mm)

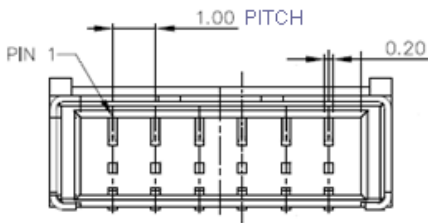
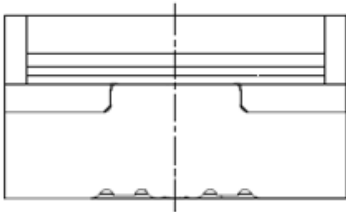

SPLCD.com  
 Supply & Purchase Cloud Platform

## Mating Connector dimension:

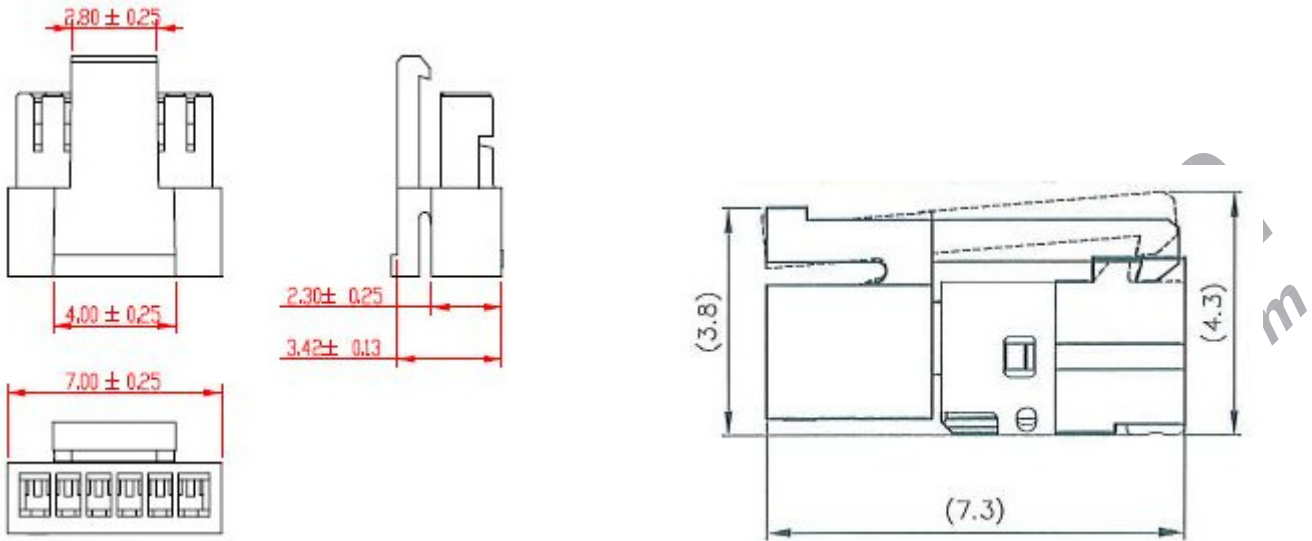

SPIC  
Supply & Purchase Clo

## 4.2.2 Connector Pin Assignment

Pin#	Symbol	Description	Remark
1	Ch1	LED Current Feedback Terminal (Channel 1)	
2	Ch2	LED Current Feedback Terminal (Channel 2)	
3	V <sub>SLED</sub>	LED Power Supply Voltage Input Terminal	
4	V <sub>SLED</sub>	LED Power Supply Voltage Input Terminal	
5	Ch3	LED Current Feedback Terminal (Channel 3)	
6	Ch4	LED Current Feedback Terminal (Channel 4)	

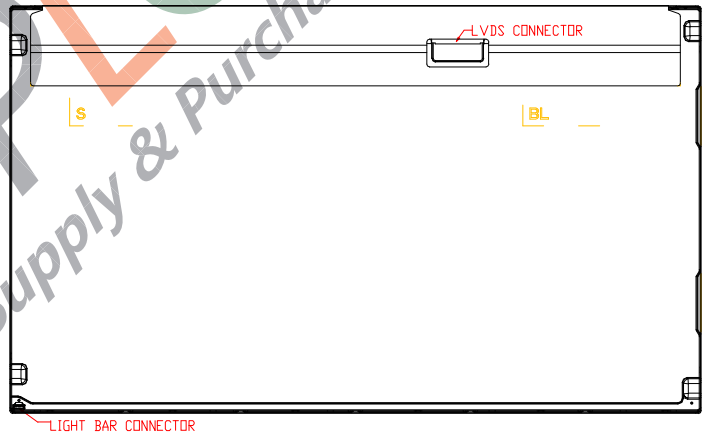
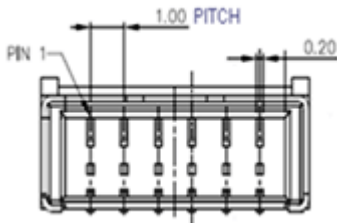

## 4.3 Electrical Characteristics

### 4.3.1 Absolute Maximum Rating

Permanent damage may occur if exceeding the following maximum rating.

(Ta=25°C)

Symbol	Description	Min	Max	Unit	Remark
Is	LED String Current	0	90	[mA]	100% duty ratio
			150	[mA]	Duty ratio ≤ 10% Pulse time=10 ms

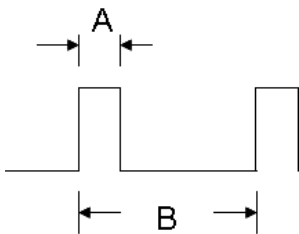

Duty ratio= (A / B) X 100% ; (A: Pulse time, B: Period)

### 4.3.2 Recommended Operating Condition

(Ta=25°C)

Symbol	Description	Min.	Typ.	Max.	Unit	Remark
Is	LED String Current	-	60	66	[mA]	100% duty ratio of LED chip
Vs	LED String Voltage	-	54.4	57.8	[Volt]	Is=60mA @ 100% duty ratio; <b>Note 4-1</b>
ΔVs	Maximum Vs Voltage Deviation of light bar	-	-	3.4	[Volt]	Is=60mA @ 100% duty ratio; <b>Note 4-2</b>
P <sub>BLU</sub>	LED Light Bar Power Consumption	-	13.1	15.3	[Watt]	<b>Note 4-3</b>
LT <sub>LED</sub>	LED Life Time	30,000	-	-	[Hour]	<b>Note 4-4</b>

**Note 4-1:**  $V_s$  (Typ.) =  $V_F$  (Typ.) X LED No. (one string);

- a.  $V_F$ : LED chip forward voltage,  $V_F$  (Min.)=2.8V,  $V_F$ (Typ.)=3.2V,  $V_F$ (Max.)=3.4V
- b. The same equation to calculate  $V_s$ (Min.) &  $V_s$  (Max.) for respective  $V_F$  (Min.) &  $V_F$ (Max.);

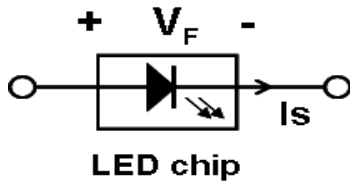

**Note 4-2:**  $\Delta V_s$  (Max.) =  $\Delta V_F$  X LED No. (one string);

- a.  $\Delta V_F$ : LED chip forward voltage deviation; (0.2 V , each Bin of LED  $V_F$ )

**Note 4-3:**  $P_{BLU}$  (Typ.) =  $V_s$  (Typ.) X  $I_s$  (Typ.) X 4 ; ( 4 is total String No. of LED Light bar)

$$P_{BLU} \text{ (Max.)} = V_s \text{ (Max.)} \times I_s \text{ (Max.)} \times 4 ;$$

**Note 4-4:** Definition of life time:

- a. Brightness of LED becomes to 50% of its original value
- b. Test condition:  $I_s = 60\text{mA}$  and  $25^\circ\text{C}$  (Room Temperature)



SPLCD.com  
 Supply & Purchase Cloud Platform

## 5 Reliability Test

AUO reliability test items are listed as following table. (*Bare Panel only*)

Items	Condition	Remark
Temperature Humidity Bias (THB)	Ta= 50°C , 80%RH, 300hours	
High Temperature Operation (HTO)	Ta= 50°C , 50%RH, 300hours	
Low Temperature Operation (LTO)	Ta= 0°C , 300hours	
High Temperature Storage (HTS)	Ta= 60°C , 300hours	
Low Temperature Storage (LTS)	Ta= -20°C , 300hours	
Vibration Test (Non-operation)	Acceleration: 1.5 Grms Wave: Random Frequency: 10 - 200 Hz Sweep: 30 Minutes each Axis (X, Y, Z)	
Shock Test (Non-operation)	Acceleration: 50 G Wave: Half-sine Active Time: 20 ms Direction: ±X, ±Y, ±Z (one time for each Axis)	
Drop Test	Height: 46 cm, package test	
Thermal Shock Test (TST)	-20°C/30min, 60°C/30min, 100 cycles	<b>Note 5-1</b>
On/Off Test	On/10sec, Off/10sec, 30,000 cycles	
ESD (Electro Static Discharge)	Contact Discharge: ± 15KV, 150pF(330Ω ) 1sec, 8 points, 25 times/ point.	<b>Note 5-2</b>
	Air Discharge: ± 15KV, 150pF(330Ω ) 1sec 8 points, 25 times/ point.	
Altitude Test	Operation:18,000 ft Non-Operation:40,000 ft	

- Note 5-1:** a. A cycle of rapid temperature change consists of varying the temperature from -20°C to 60°C, and back again. Power is not applied during the test.  
b. After finish temperature cycling, the unit is placed in normal room ambient for at least 4 hours before power on.

- Note 5-2:** EN61000-4-2, ESD class B: Certain performance degradation allowed  
No data lost  
Self-recoverable  
No hardware failures.



## 6 Shipping Label

The label is on the panel as shown below:

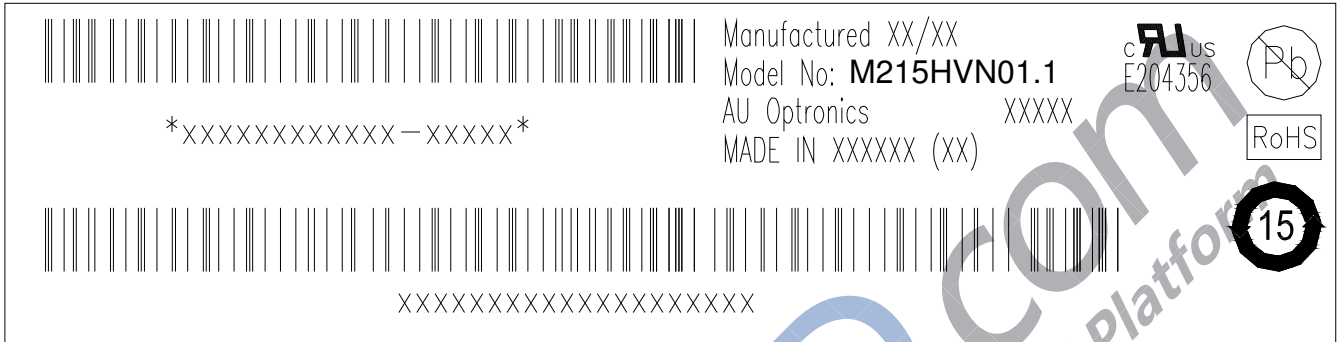

**Note 6-1:** For Pb Free products, AUO will add  for identification.

**Note 6-2:** For RoHS compatible products, AUO will add  for identification.

**Note 6-3:** For China RoHS compatible products, AUO will add  for identification.

**Note 6-4:** The Green Mark will be presented only when the green documents have been ready by AUO Internal Green Team.



## 7 Mechanical Characteristics

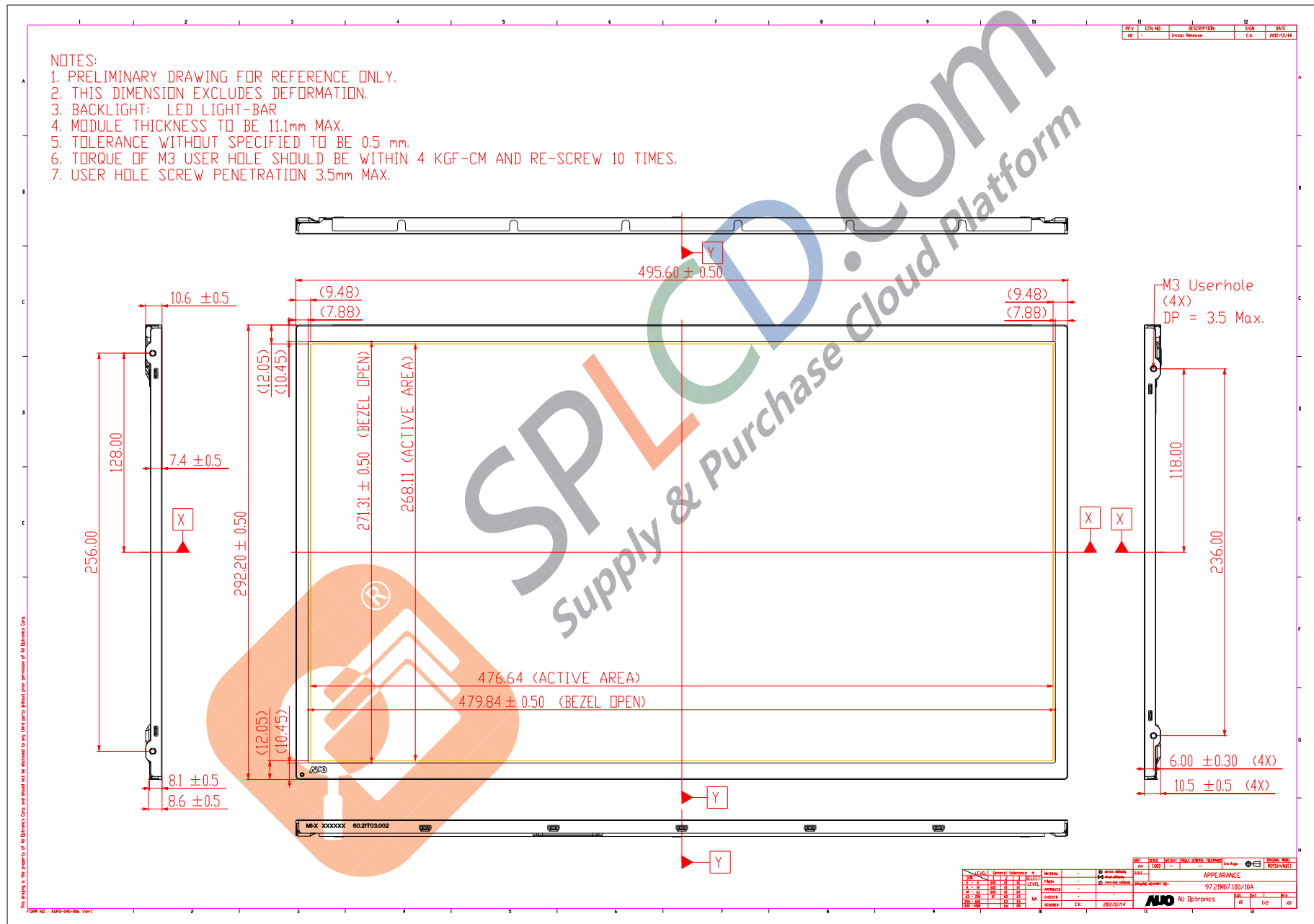

REV	CDR NO	DESCRIPTION	DATE
1		Initial Release	2023/12/14

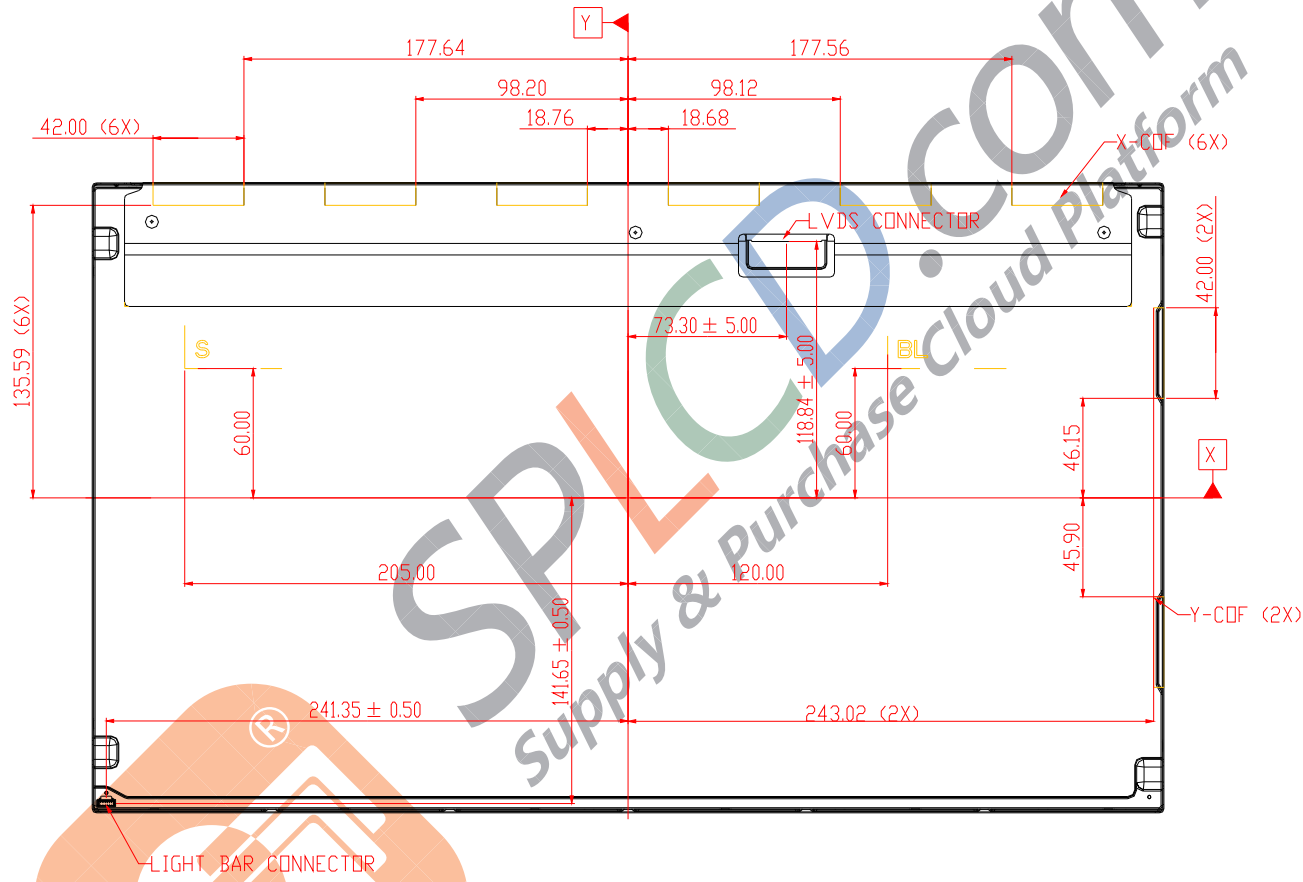

**Avoid touching COF position when doing mechanical design**

This drawing is the property of AU Optronics Corp and shall not be released to any third party without prior permission of AU Optronics Corp.

REV	CDR NO	DESCRIPTION	DATE
1		Initial Release	2023/12/14

GENERAL INFORMATION	NAME	972M07100/10A
APPEARANCE	DATE	2023/12/14
DESIGNER	CHK	2/2
DATE	REV	NO

# 8 Packing Specification

## 8.1 Packing Flow

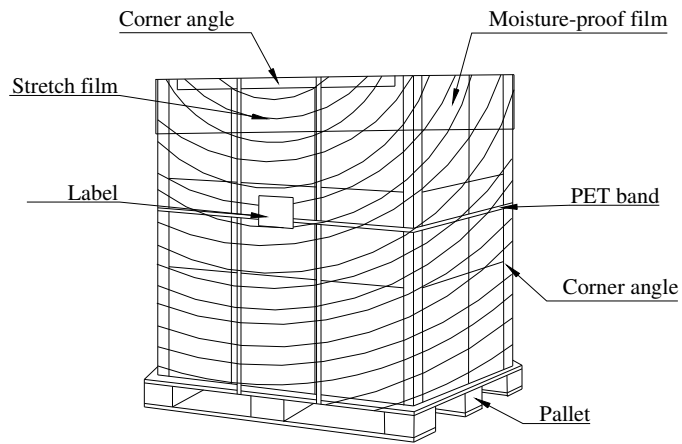
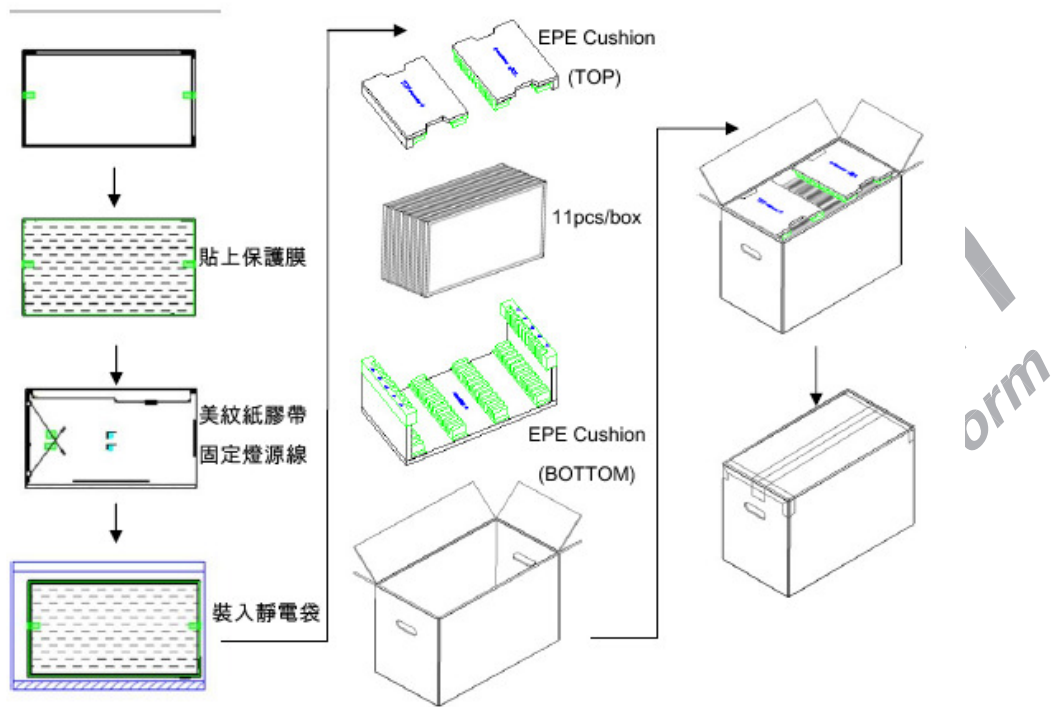

## 8.2 Pallet and shipment information

Item	Specification			Remark
	Q'ty	Dimension	Weight(kg)	
Panel	1	495.6(H)mm × 292.2(V)mm × 10.6(D)mm	1.8	
Cushion	1	-	0.40	
Box	1	556(L)mm × 292(W)mm × 375(H)mm	0.95	without Panel & cushion
Packing Box	11 pcs/Box	556(L)mm × 292(W)mm × 375(H)mm	20.6	with panel & cushion
Pallet	1	1150(L)mm × 910(W)mm × 132(H)mm	12.00	
Pallet after Packing	18 boxes/pallet	1150(L)mm × 910(W)mm × 1257(H)mm	382.8	



SPLCD.com  
Supply & Purchase Cloud Platform