



# Product Specification

M215HW02 V0

AU OPTRONICS CORPORATION

- ( ) Preliminary Specification  
 ( V ) Final Specification

<b>Module</b>	<b>21.5" Color TFT-LCD</b>
<b>Model Name</b>	<b>M215HW02 V0</b>

<p><b>Customer</b> _____ <b>Date</b> _____</p> <p><b>Approved by</b></p> <p>_____</p>	<p><b>Approved by</b> _____ <b>Date</b> _____</p> <p><i>Paul Huang</i> _____ 2011/01/17</p> <p><b>Prepared by</b></p> <p>_____</p> <p><i>Ken Ho</i> _____ 2011/01/17</p>
<p>Note: This Specification is subject to change without notice.</p>	<p>Desktop Display Business Group / AU Optronics corporation</p>



## Contents

<b>1.0 Handling Precautions .....</b>	<b>5</b>
<b>2.0 General Description .....</b>	<b>6</b>
2.1 Display Characteristics.....	6
2.2 Optical Characteristics .....	7
<b>3.0 Functional Block Diagram .....</b>	<b>10</b>
<b>4.0 Absolute Maximum Ratings .....</b>	<b>12</b>
4.1 TFT LCD Module .....	12
4.2 Backlight Unit .....	12
4.3 Absolute Ratings of Environment.....	12
<b>5.0 Electrical characteristics .....</b>	<b>14</b>
5.1 TFT LCD Module .....	14
5.1.1 Power Specification .....	14
5.1.2 Signal Electrical Characteristics.....	15
5.2 Backlight Unit .....	17
<b>6.0 Signal Characteristic.....</b>	<b>18</b>
6.1 Pixel Format Image .....	18
6.2 The input data format.....	18
6.3 Signal Description .....	19
6.4 Timing Characteristics .....	21
6.5 Timing diagram .....	22
6.6 Power ON/OFF Sequence .....	23
<b>7.0 Connector &amp; Pin Assignment.....</b>	<b>24</b>
7.1 TFT LCD Module .....	24
7.1.1 Pin Assignment .....	24
7.2 Connector on Backlight Unit. ....	25
7.2.1 Pin assignment .....	25
<b>8.0 Reliability Test.....</b>	<b>26</b>
<b>9.0 Shipping Label .....</b>	<b>27</b>
<b>10 Mechanical Characteristics .....</b>	<b>28</b>
<b>11 Packing Specification .....</b>	<b>29</b>



# Product Specification

M215HW02 V0

AU OPTRONICS CORPORATION

## Record of Revision

Version and Date	Page	Old description	New Description	Remark																												
0.1 2010/10/15		First Version for Customer																														
0.2 2010/11/22	5	RGB 6 bits + Hi-FRC data	RGB 8 bits data	Revised																												
	5	Power consumption (VDD line + LED line): 21 watt	Power consumption (VDD line + LED line): 19.5 watt	Revised																												
	11	Maximum LED current: 60 mA	Maximum LED current: 90 mA.	Revised																												
	15	1. Maximum LED operation current: 80 mA. 2. Light bar operation voltage: 68 voltage. 3. Maximum BLU power consumption: 16.32 watt.	1. Maximum LED operation current: 90 mA. 2. Light bar operation voltage: 72 voltage. 3. Maximum BLU power consumption: 24.48 watt.	Revised																												
1.0 2010/01/17	5	N/A	14) When storing module as spares for a long time, the following precaution is necessary: Store them in a dark place. Do not expose the module to sunlight or fluorescent light. Keep the temperature between 5°C and 35°C at normal humidity	Add																												
	7	1. Viewing Angle, Horizontal Min./Typ. 75/75/85/85 2. Viewing Angle, Vertical Min./Typ. 70/70/80/80	1. Viewing Angle, Horizontal Min./Typ. 150 / 178. 2. Viewing Angle, Vertical Min./Typ. 150 / 178.	Revised																												
	9	$T_{rR} + T_{rF} = 25 \text{ msec (typ.)}$ .	$T_{rR} + T_{rF} = 16 \text{ msec (typ.)}$ .	Revised																												
	12	N/A	<table border="1" style="width: 100%; border-collapse: collapse;"> <tr> <td style="font-size: small;">(Glass Surface Temperature (Operation))</td> <td style="font-size: small;">TGS</td> <td style="font-size: small;">0</td> <td style="font-size: small;">+65</td> <td style="font-size: small;">[C]</td> <td style="font-size: small;">Note 3, Note 4</td> </tr> </table> <p><b>Note 3.</b> 1.) 90% RH Max ( <math>T_a \leq 39^\circ\text{C}</math> ) ;            2. ) Max wet-bulb temperature at <math>39^\circ\text{C}</math> or less. ( <math>T_a \leq 39^\circ\text{C}</math> ); 3.) No condensation</p> <p><b>Note4.</b> Function Judged only</p>	(Glass Surface Temperature (Operation))	TGS	0	+65	[C]	Note 3, Note 4	Add																						
(Glass Surface Temperature (Operation))	TGS	0	+65	[C]	Note 3, Note 4																											
	14	N/A	Add IDD current and PDD power at 75 Hz. <table border="1" style="width: 100%; border-collapse: collapse;"> <tr> <td style="font-size: small;">IDD</td> <td style="font-size: small;">Input Current</td> <td style="font-size: small;">--</td> <td style="font-size: small;">0.7</td> <td style="font-size: small;">0.8</td> <td style="font-size: small;">[A]</td> <td style="font-size: small;">VDD= 5.0V, All white pattern, At 60Hz</td> </tr> <tr> <td></td> <td></td> <td style="font-size: small;">--</td> <td style="font-size: small;">0.81</td> <td style="font-size: small;">0.89</td> <td style="font-size: small;">[A]</td> <td style="font-size: small;">VDD= 5.0V, All white pattern, At 75Hz</td> </tr> <tr> <td style="font-size: small;">PDD</td> <td style="font-size: small;">VDD Power</td> <td style="font-size: small;">--</td> <td style="font-size: small;">3.5</td> <td style="font-size: small;">4.4</td> <td style="font-size: small;">[Watt]</td> <td style="font-size: small;">VDD= 5.0V, All white pattern, At 60Hz</td> </tr> <tr> <td></td> <td></td> <td style="font-size: small;">--</td> <td style="font-size: small;">4.05</td> <td style="font-size: small;">4.9</td> <td style="font-size: small;">[Watt]</td> <td style="font-size: small;">VDD= 5.0V, All white pattern, At 75Hz</td> </tr> </table>	IDD	Input Current	--	0.7	0.8	[A]	VDD= 5.0V, All white pattern, At 60Hz			--	0.81	0.89	[A]	VDD= 5.0V, All white pattern, At 75Hz	PDD	VDD Power	--	3.5	4.4	[Watt]	VDD= 5.0V, All white pattern, At 60Hz			--	4.05	4.9	[Watt]	VDD= 5.0V, All white pattern, At 75Hz	Add
IDD	Input Current	--	0.7	0.8	[A]	VDD= 5.0V, All white pattern, At 60Hz																										
		--	0.81	0.89	[A]	VDD= 5.0V, All white pattern, At 75Hz																										
PDD	VDD Power	--	3.5	4.4	[Watt]	VDD= 5.0V, All white pattern, At 60Hz																										
		--	4.05	4.9	[Watt]	VDD= 5.0V, All white pattern, At 75Hz																										



# Product Specification

M215HW02 V0

AU OPTRONICS CORPORATION

Signal	Item	Symbol	Min	Typ	Max	Unit	Item	Symbol	Min	Typ	Max	Unit			
21	Vertical Section	Period	T <sub>v</sub>	1080	1120	2047	Th	Data CLK	Tclk	40	72	83	[MHz]	Revised	
		Active	Tdisp(v)	1080	1080	1080	Th	Period	Th	1004	1050	2047	[Tclk]		
		Blanking	Tbp(v)+Tfp(v)+PWvs	8	40	987	Th	Display Area	Tdisp(h)	960	960	960	[Tclk]		
	Horizontal Section	Period	Th	1034	1060	2047	Tclk	Blanking	Tblk(h)	44	80	1087	[Tclk]		
		Active	Tdisp(h)	960	960	960	Tclk	Period	T <sub>v</sub>	1088	1130	2047	[Th]		
		Blanking	Tbp(h)+Tfp(h)+PWhs	74	100	1087	Tclk	Display Area	Tdisp(h)	1080	1080	1080	[Th]		
	Clock	Period	Tclk	25	13	11	ns	Blanking	Tblk(h)	8	50	967	[Th]		
		Frequency	Freq	40	75	90	MHz	Frame Rate	F	50	60	75	[Hz]		
	Frame rate	Frame rate	F	50	60	75	Hz								
	28	N/A						Avoid touching COF position when doing mechanical design.							Add



# Product Specification

M215HW02 V0

AU OPTRONICS CORPORATION

## 1.0 Handling Precautions

- 1) Since front polarizer is easily damaged, pay attention not to scratch it.
- 2) Be sure to turn off power supply when inserting or disconnecting from input connector.
- 3) Wipe off water drop immediately. Long contact with water may cause discoloration or spots.
- 4) When the panel surface is soiled, wipe it with absorbent cotton or other soft cloth.
- 5) Since the panel is made of glass, it may break or crack if dropped or bumped on hard surface.
- 6) Since CMOS LSI is used in this module, take care of static electricity and insure human earth when handling.
- 7) Do not open or modify the Module Assembly.
- 8) Do not press the reflector sheet at the back of the module to any directions.
- 9) In case if a Module has to be put back into the packing container slot after once it was taken out from the container, do not press the center of the LED lightbar edge. Instead, press at the far ends of the LED light bar edge softly. Otherwise the TFT Module may be damaged.
- 10) At the insertion or removal of the Signal Interface Connector, be sure not to rotate nor tilt the Interface Connector of the TFT Module.
- 11) After installation of the TFT Module into an enclosure, do not twist nor bend the TFT Module even momentary. At designing the enclosure, it should be taken into consideration that no bending/twisting forces are applied to the TFT Module from outside. Otherwise the TFT Module may be damaged.
- 12) Small amount of materials having no flammability grade is used in the LCD module. The LCD module should be supplied by power complied with requirements of Limited Power Source (IEC60950 or UL1950), or be applied exemption.
- 13) Please avoid touching COF position while you are doing mechanical design.
- 14) When storing modules as spares for a long time, the following precaution is necessary:  
Store them in a dark place. Do not expose the module to sunlight or fluorescent light. Keep the temperature between 5°C and 35°C at normal humidity.



# Product Specification

M215HW02 V0

AU OPTRONICS CORPORATION

## 2.0 General Description

This specification applies to the 21.5 inch-FHD Color a-Si TFT-LCD Module M215HW02. The display supports the FHD - 1920(H) x 1080(V) screen format and 16.7M colors (RGB 8-bits data). The light source of this TFT-LCD module is W-LED. All input signals are 2-channel LVDS interface and this module doesn't contain a driver for backlight.

## 2.1 Display Characteristics

The following items are characteristics summary on the table under 25°C condition:

ITEMS	Unit	SPECIFICATIONS
Screen Diagonal	[mm]	546.86(21.53")
Active Area	[mm]	476.64 (H) x 268.11 (V)
Pixels H x V		1920(x3) x 1080
Pixel Pitch	[um]	248.25 (per one triad) x248.25
Pixel Arrangement		R.G.B. Vertical Stripe
Display Mode		VA Mode, Normally Black
White Luminance ( Center )	[cd/m <sup>2</sup> ]	250cd/m <sup>2</sup> (Typ.)
Contrast Ratio		5000 (Typ.)
Optical Response Time	[msec]	16 ms (Typ., on/off)
Nominal Input Voltage VDD	[Volt]	+5.0 V
Power Consumption (VDD line + LED line)	[Watt]	19.5 (Typ.) (without driver board, all white pattern)
Weight	[Grams]	1800 (max.)
Physical Size	[mm]	495.6(W) x 292.2(H) x 10.7(D) Max.
Electrical Interface		Dual channel LVDS
Support Color		16.7M colors (RGB 8 bits)
Surface Treatment		Anti-Glare, 3H
Temperature Range		
Operating	[°C]	0 to +50
Storage (Shipping)	[°C]	-20 to +60
RoHS Compliance		RoHS Compliance
TCO Compliance		TCO 5.1 Compliance



# Product Specification

M215HW02 V0

AU OPTRONICS CORPORATION

## 2.2 Optical Characteristics

The optical characteristics are measured under stable conditions at 25°C:

Item	Unit	Conditions	Min.	Typ.	Max.	Note
Viewing Angle	[degree]	Horizontal (Right) CR = 10 (Left)	150	178	-	<b>2</b>
		Vertical (Up) CR = 10 (Down)	150	178	-	
Contrast ratio		Normal Direction	3000	5000	-	<b>3</b>
Response Time	[msec]	Raising Time (T <sub>rR</sub> )	-	10	12	<b>4</b>
		Falling Time (T <sub>rF</sub> )	-	6	7	
		Raising + Falling	-	16	19	
Color / Chromaticity Coordinates (CIE)		Red x	0.609	0.639	0.669	<b>5</b>
		Red y	0.303	0.333	0.363	
		Green x	0.304	0.334	0.364	
		Green y	0.593	0.623	0.653	
		Blue x	0.125	0.155	0.185	
		Blue y	0.018	0.048	0.078	
Color Coordinates (CIE) White		White x	0.283	0.313	0.343	<b>5</b>
		White y	0.299	0.329	0.359	
Central Luminance	[cd/m <sup>2</sup> ]		200	250	-	<b>6</b>
Luminance Uniformity	[%]		75	80	-	<b>7</b>
Crosstalk (in 60Hz)	[%]				1.5	<b>8</b>
Flicker	dB				-20	<b>9</b>





# Product Specification

M215HW02 V0

AU OPTRONICS CORPORATION

## Note 1: Measurement method

The LCD module should be stabilized at given temperature for 30 minutes to avoid abrupt temperature change during measuring (at surface  $35^{\circ}\text{C}$ ). In order to stabilize the luminance, the measurement should be executed after lighting Backlight for 30 minutes in a stable, windless and dark room.

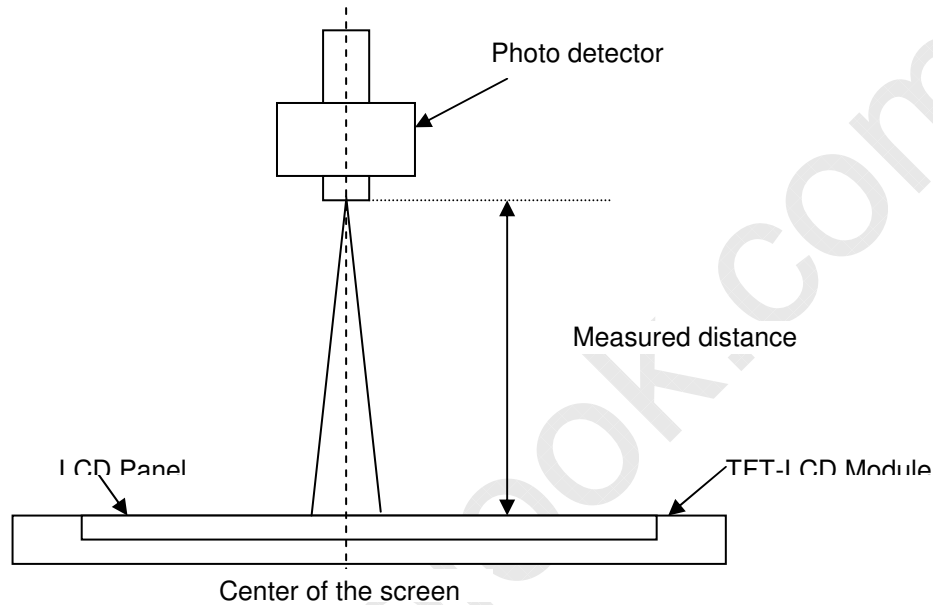

## Note 2: Definition of viewing angle measured by ELDIM (EZContrast 88)

Viewing angle is the measurement of contrast ratio  $\geq 10$ , at the screen center, over a  $180^{\circ}$  horizontal and  $180^{\circ}$  vertical range (off-normal viewing angles). The  $180^{\circ}$  viewing angle range is broken down as follows;  $90^{\circ}$  ( $\theta$ ) horizontal left and right and  $90^{\circ}$  ( $\phi$ ) vertical, high (up) and low (down). The measurement direction is typically perpendicular to the display surface with the screen rotated about its center to develop the desired measurement viewing angle.

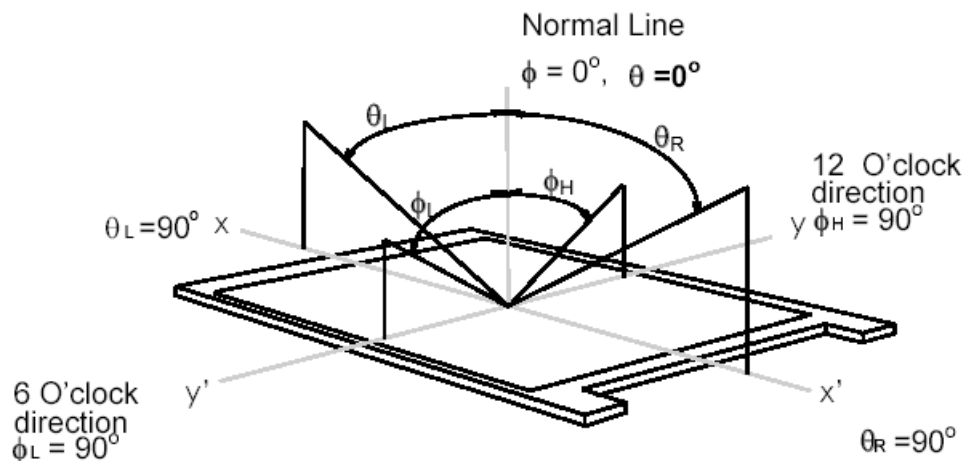





# Product Specification

M215HW02 V0

AU OPTRONICS CORPORATION

**Note 3: Contrast ratio is** measured by TOPCON SR-3

**Note 4: Definition of Response time** measured by Westar TRD-100A

The output signals of photo detector are measured when the input signals are changed from “Full Black” to “Full White” (rising time,  $T_{rR}$ ), and from “Full White” to “Full Black” (falling time,  $T_{rF}$ ), respectively. The response time is interval between the 10% and 90% (1 frame at 60 Hz) of amplitudes.

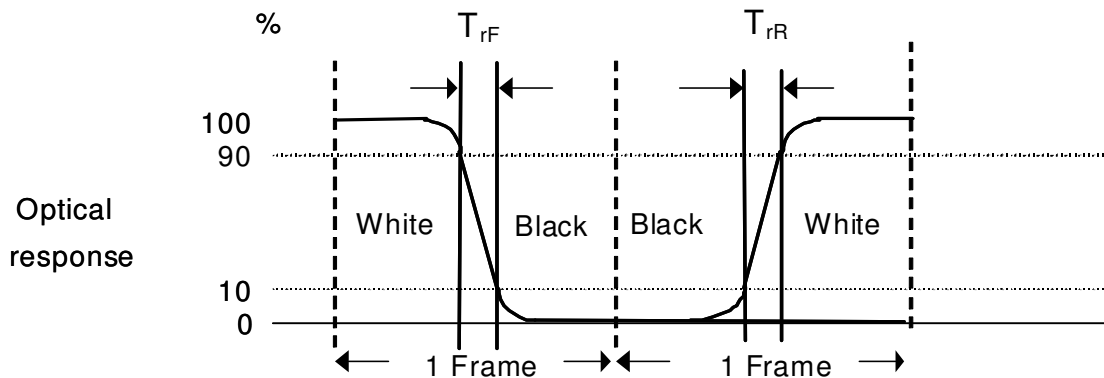

$T_{rR} + T_{rF} = 16$  msec (typ.).

**Note 5: Color chromaticity and coordinates (CIE)** is measured by TOPCON SR-3

**Note 6: Central luminance** is measured by TOPCON SR-3

**Note 7: Luminance uniformity of these 9 points** is defined as below and measured by TOPCON SR-3

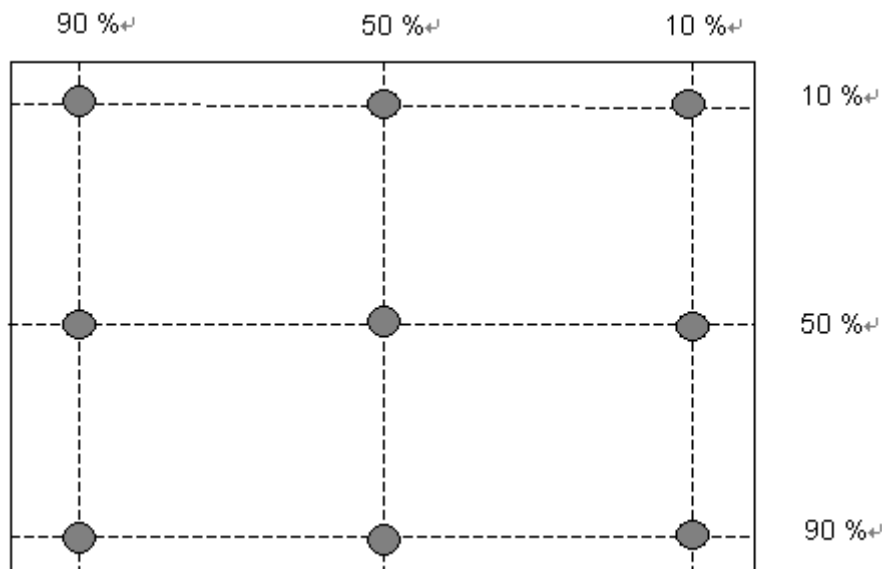

$$\text{Uniformity} = \frac{\text{Minimum Luminance in 9 points (1-9)}}{\text{Maximum Luminance in 9 Points (1-9)}}$$

**Note 8: Crosstalk** is defined as below and measured by TOPCON SR-3



# Product Specification

M215HW02 V0

AU OPTRONICS CORPORATION

$$CT = | YB - YA | / YA \times 100 (\%)$$

Where

YA = Luminance of measured location without gray level 0 pattern (cd/m<sup>2</sup>)

YB = Luminance of measured location with gray level 0 pattern (cd/m<sup>2</sup>)

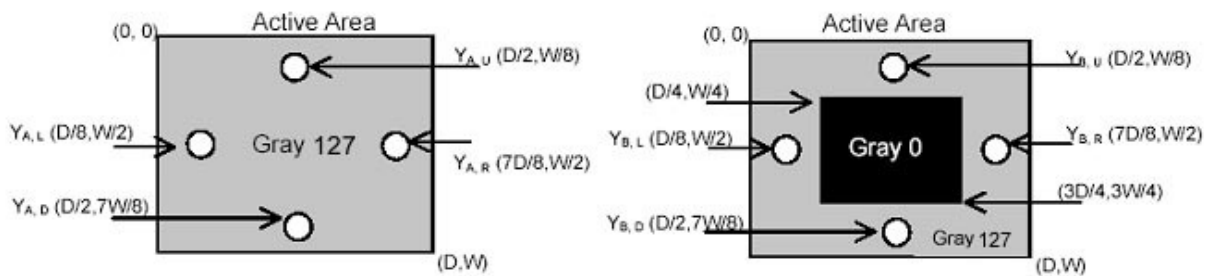

**Note 9: Test Pattern: Subchecker Pattern** measured by TOPCON SR-3

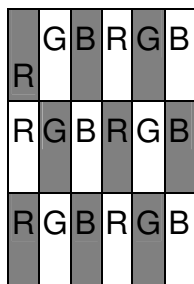

Gray Level = L127



Gray Level = L0

Method: Record dBV & DC value with TRD-100

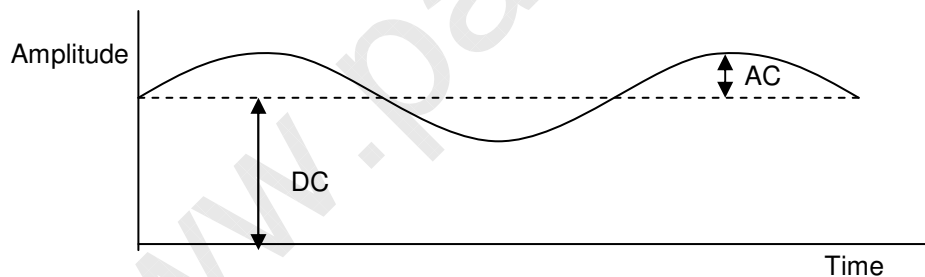

$$\text{Flicker (dB)} = 20 \log \frac{\text{AC Level (at 30 Hz)}}{\text{DC Level}}$$

## 3.0 Functional Block Diagram

The following diagram shows the functional block of the 21.5 inch Color TFT-LCD Module:



# Product Specification

M215HW02 V0

AU OPTRONICS CORPORATION

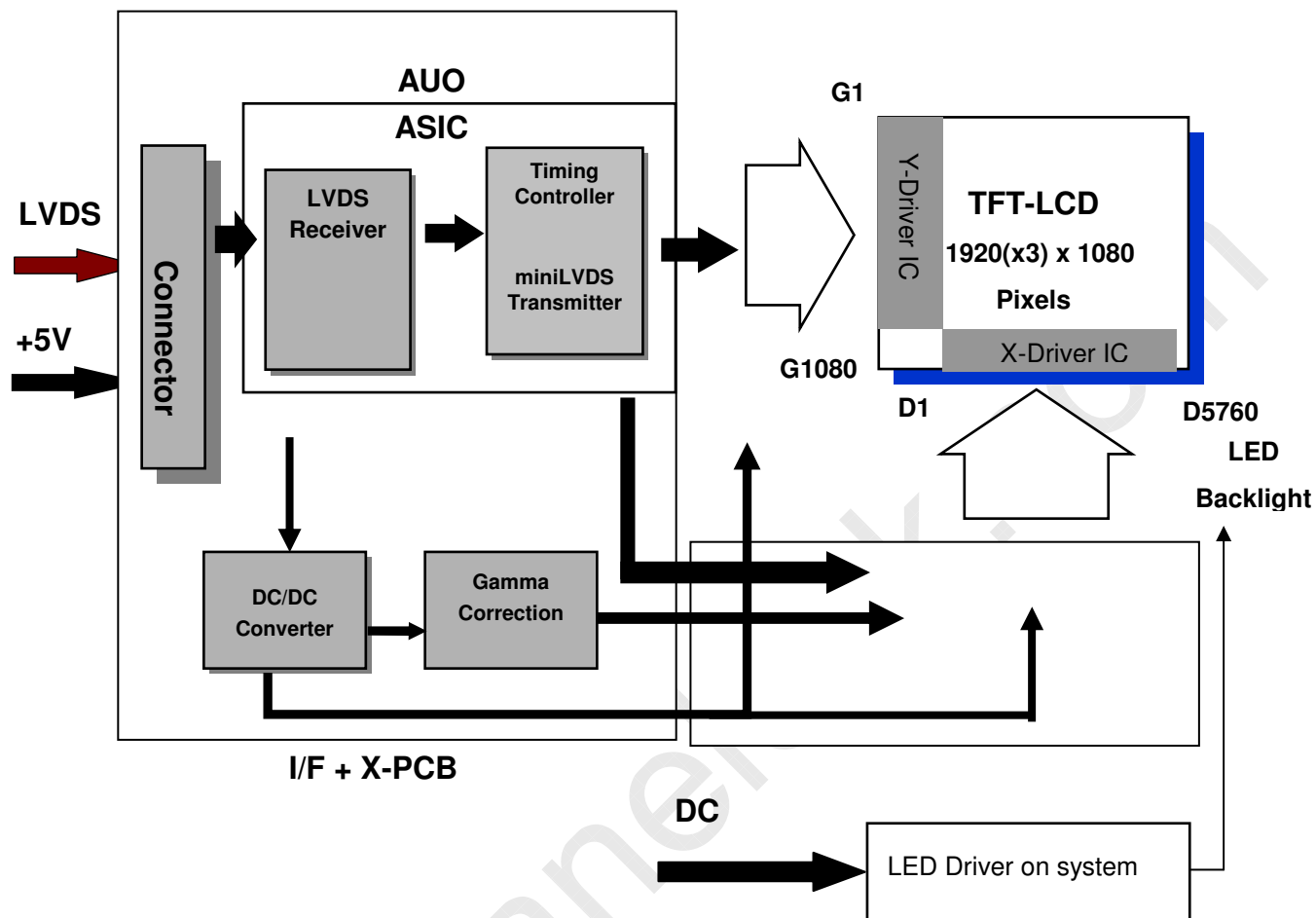

## I/F PCB Interface:

FI-XPB30SRLA-HF11 (JAE)

01-187121-30091-3 (P-TWO)

## Mating Type:

FI-X30HL(Locked Type)



# Product Specification

M215HW02 V0

AU OPTRONICS CORPORATION

## 4.0 Absolute Maximum Ratings

Absolute maximum ratings of the module are as following:

### 4.1 TFT LCD Module

Item	Symbol	Min	Max	Unit	Conditions
Logic/LCD Drive Voltage	VDD	0	5.5	[Volt]	<b>Note 1,2</b>

### 4.2 Backlight Unit

Item	Symbol	Min	Max	Unit	Conditions
LED Current	ILED	-	90	[mA]	<b>Note 1,2</b>

### 4.3 Absolute Ratings of Environment

Item	Symbol	Min.	Max.	Unit	Conditions
Operating Temperature	TOP	0	+50	[°C]	<b>Note 3</b>
Glass Surface Temperature (Operation)	TGS	0	+65	[°C]	<b>Note 3, Note 4</b>
Operation Humidity	HOP	5	90	[%RH]	<b>Note 3</b>
Storage Temperature	TST	-20	+60	[°C]	
Storage Humidity	HST	5	90	[%RH]	

**Note 1:** With in Ta (25°C)

**Note 2:** Permanent damage to the device may occur if exceeding maximum values

**Note 3:** For quality performance, please refer to AUO IIS(Incoming Inspection Standard).

1. 90% RH Max ( Ta ≤39°C)

2. Max wet-bulb temperature at 39°C or less. ( Ta ≤39°C)

3. No condensation.

**Note4:** Function judge only.



# Product Specification

M215HW02 V0

AU OPTRONICS CORPORATION

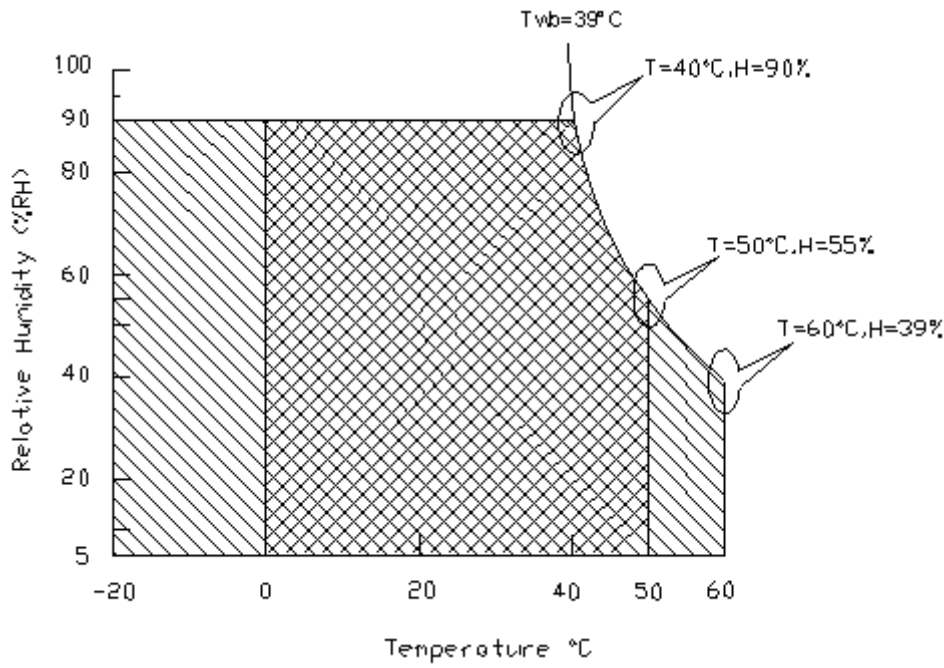

Operating Range



Storage Range

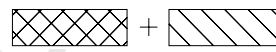



# Product Specification

M215HW02 V0

AU OPTRONICS CORPORATION

## 5.0 Electrical characteristics

### 5.1 TFT LCD Module

#### 5.1.1 Power Specification

Input power specifications are as following:

Symbol	Parameter	Min	Typ	Max	Unit	Conditions
VDD	Logic/LCD Drive Voltage	4.5	5.0	5.5	[Volt]	+/-10%
IDD	Input Current	-	0.7	0.8	[A]	VDD= 5.0V, All white pattern, At 60Hz
		-	0.81	0.89	[A]	VDD= 5.0V, All white pattern At 75Hz,
PDD	VDD Power	-	3.5	4.4	[Watt]	VDD= 5.0V, All white pattern, At 60Hz
		-	4.05	4.9	[Watt]	VDD= 5.0V, All white pattern At 75Hz,
IRush	Inrush Current	-	-	3	[A]	<b>Note 1</b>
VDDrp	Allowable Logic/LCD Drive Ripple Voltage	-	-	500	[mV] p-p	VDD= 5.0V, All white Pattern At 75Hz

**Note 1:** Measurement conditions:

The duration of rising time of power input is 470us.

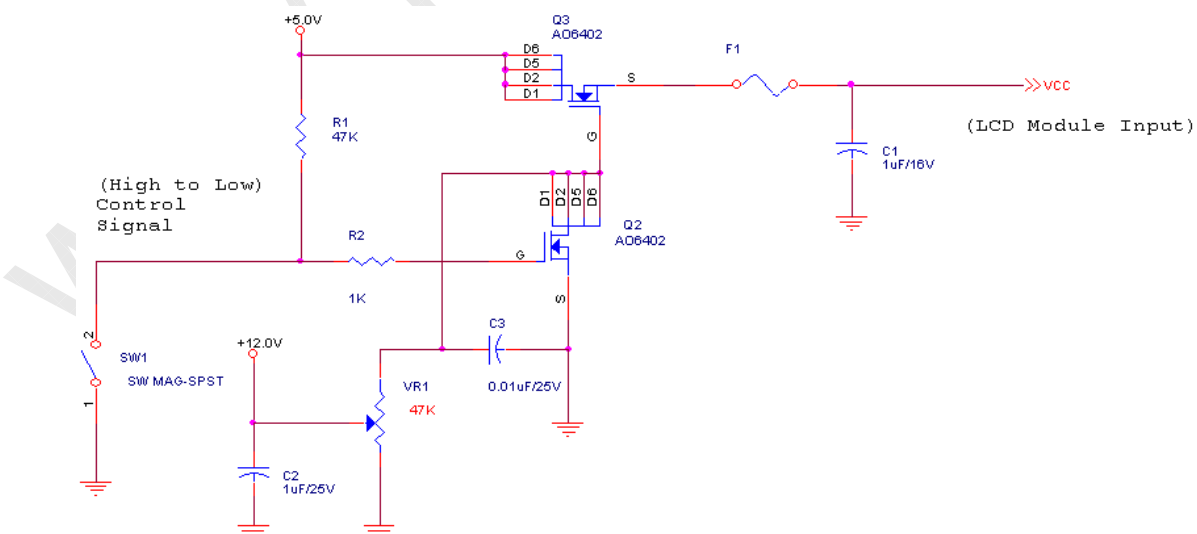



# Product Specification

M215HW02 V0

AU OPTRONICS CORPORATION

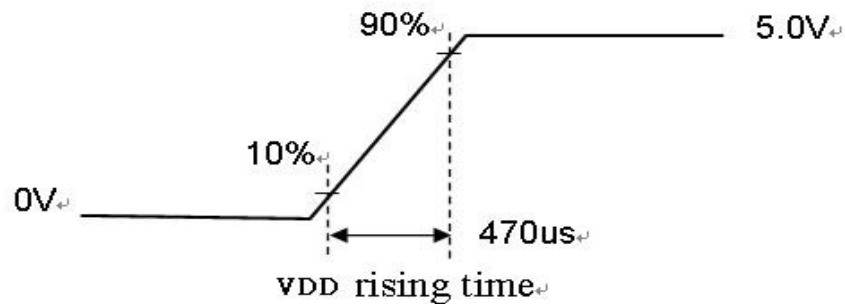

## 5.1.2 Signal Electrical Characteristics

Input signals shall be low or Hi-Z state when VDD is off. Please refer to specifications of SN75LVDS82DGG (Texas Instruments) in detail.

### 1. DC Characteristics of each signal are as following:

Symbol	Parameter	Min	Typ	Max	Units	Condition
$V_{TH}$	Differential Input High Threshold	-	-	+100	[mV]	$V_{CM} = 1.2V$ , <b>Note 1</b>
$V_{TL}$	Differential Input Low Threshold	-100	-	-	[mV]	$V_{CM} = 1.2V$ <b>Note 1</b>
$ V_{ID} $	Input Differential Voltage	100	-	600	[mV]	<b>Note 1</b>
$V_{CM}$	Differential Input Common Mode Voltage	+1.0	+1.2	+1.5	[V]	$V_{TH} - V_{TL} = 200MV$ (max) <b>Note 1</b>

**Note 1:** LVDS Signal Waveform





# Product Specification

M215HW02 V0

AU OPTRONICS CORPORATION

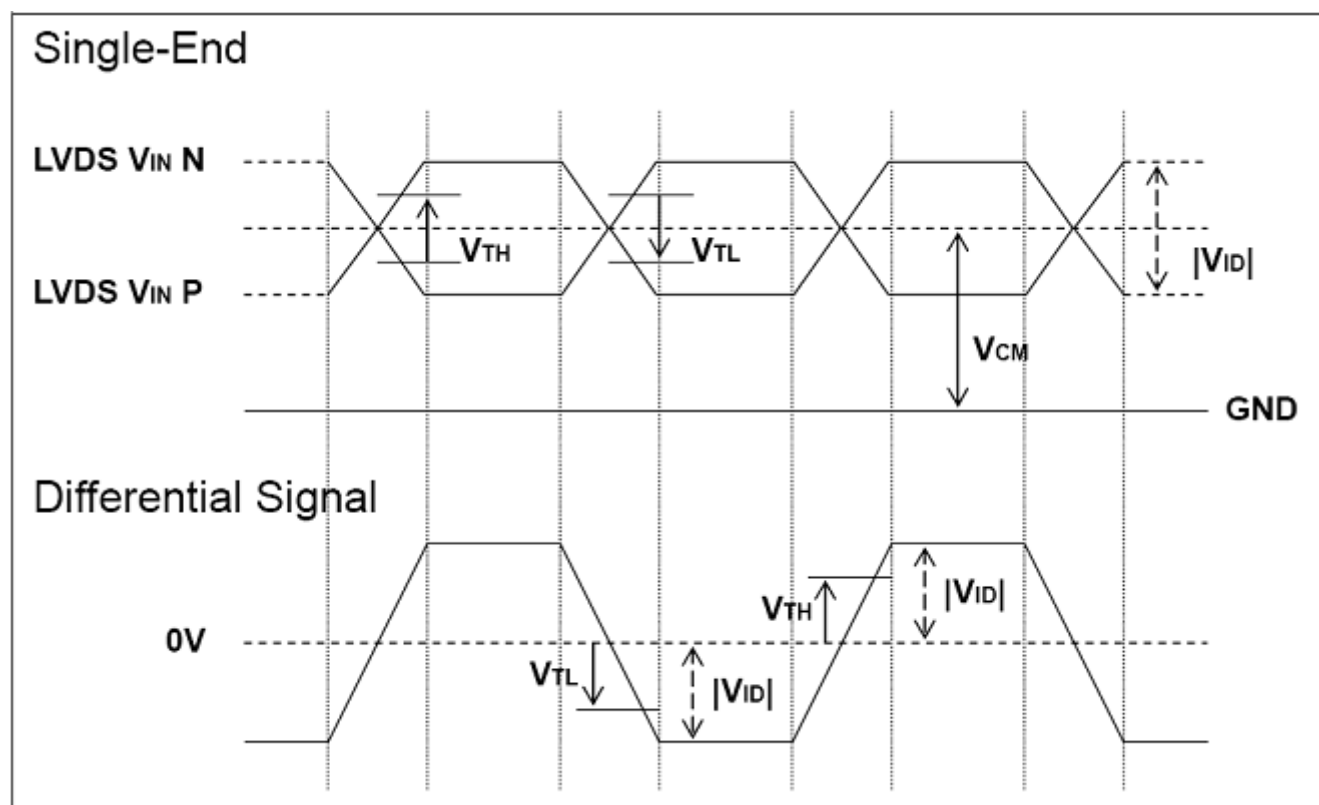

## 2. AC Characteristics

Description	Symbol	Min	Max	Unit	Note
Maximum deviation of input clock frequency during SSC	FDEV	-	$\pm 3$	%	
Maximum modulation frequency of input clock during SSC	FMOD	-	200	KHz	

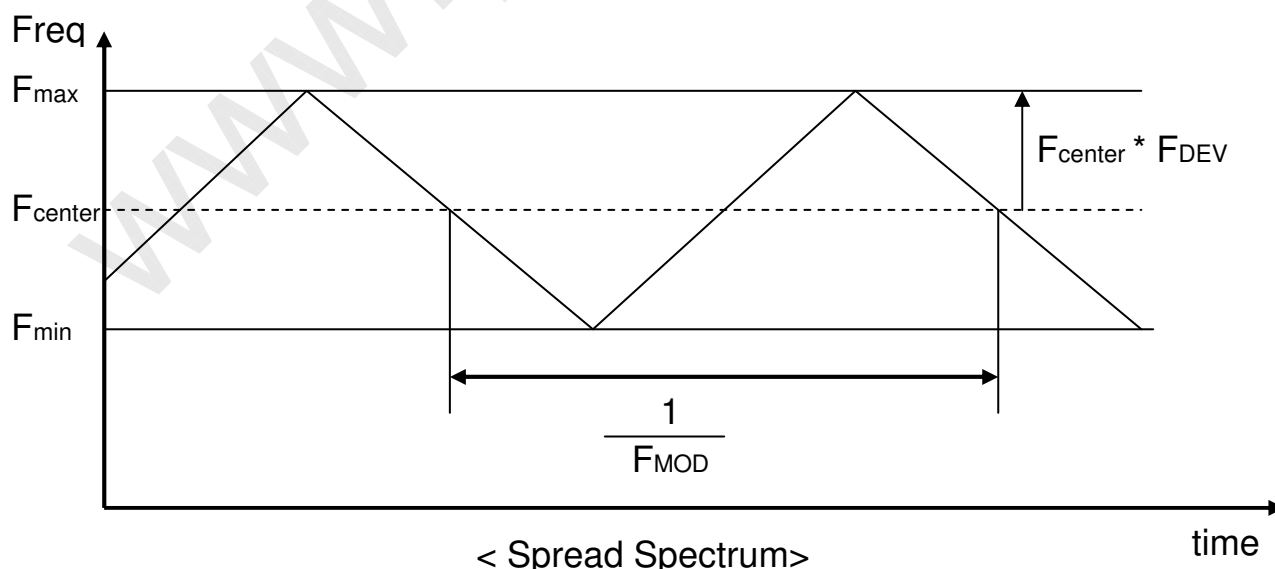



# Product Specification

M215HW02 V0

AU OPTRONICS CORPORATION

## 5.2 Backlight Unit

Parameter guideline for LED driving is under stable conditions at 25°C (Room Temperature):

Symbol	Parameter	Min.	Typ.	Max.	Unit	Note
$I_{R_{LED}}$	LED Operation Current	-	60	90	[mA] <b>Note 1</b>	<b>Operating with fixed driving current</b>
$V_{LB}$	Light Bar Operation Voltage (for reference)	-	66	68	[Volt] <b>Note 2</b>	
$P_{BLU}$	BLU Power consumption (for reference)	-	15.84	24.48	[Watt]	
$LT_{LED}$	LED life Time (Typical)	30,000	-	-	[Hour] <b>Note 3</b>	

**Note 1** :The specified current is input LED chip 100% duty current.

**Note 2** : The value showed in the table is one light bar's operation voltage.

**Note 3** : Definition of life time : brightness becomes 50% of its original value. The minimum life time of LED unit is on the condition of  $I_{R_{LED}} = 60\text{mA}$  and  $25\pm 2^\circ\text{C}$  (Room temperature).

**Note 4** : Each LED light bar consists of 80 pcs LED package ( 4 strings x 20 pcs / string ).



# Product Specification

M215HW02 V0

AU OPTRONICS CORPORATION

## 6.0 Signal Characteristic

### 6.1 Pixel Format Image

Following figure shows the relationship of the input signals and LCD pixel format.

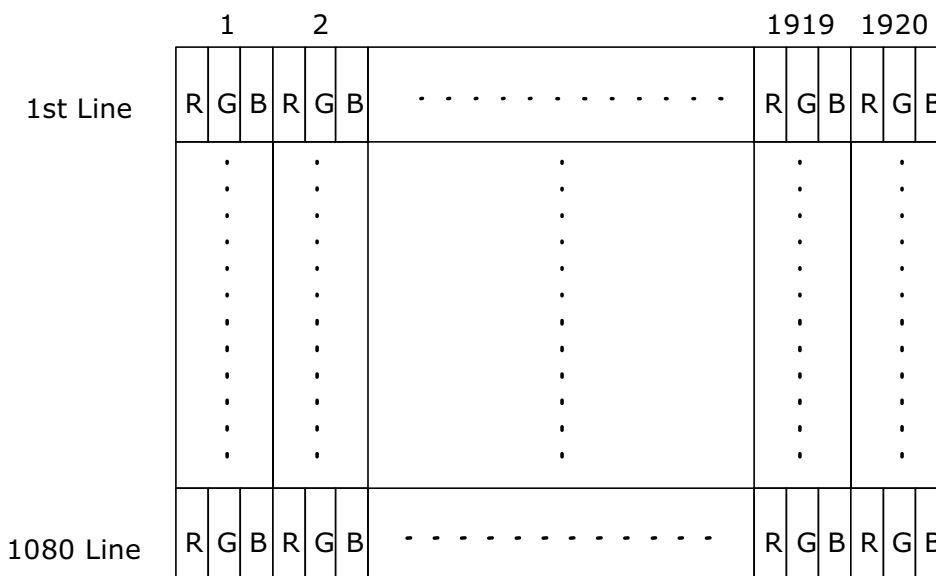

### 6.2 The input data format

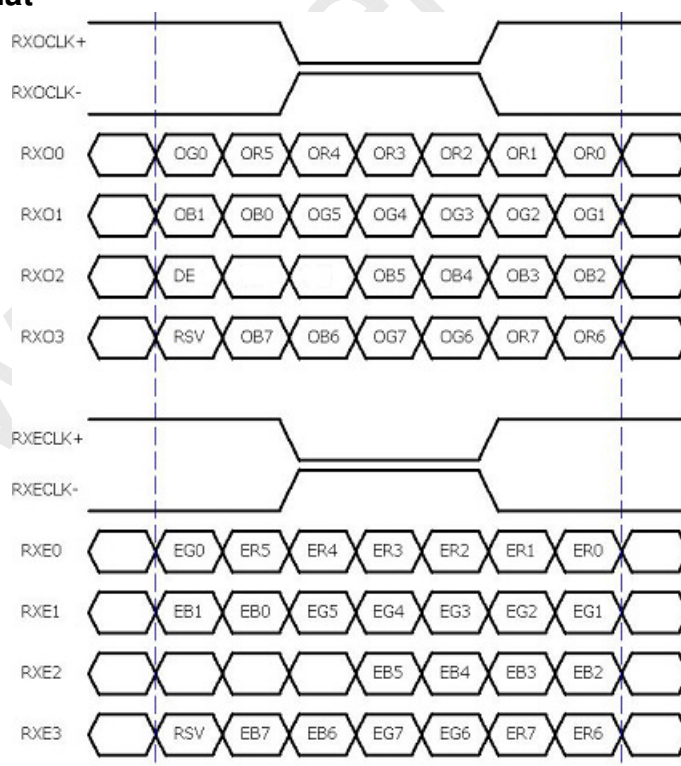

**Note 1:** R/G/B data 7:MSB, R/G/B data 0:LSB O = "Odd Pixel Data" E = "Even Pixel Data"



# Product Specification

M215HW02 V0

AU OPTRONICS CORPORATION

## 6.3 Signal Description

The module using one LVDS receiver SN75LVDS82(Texas Instruments). LVDS is a differential signal technology for LCD interface and high speed data transfer device. LVDS transmitters shall be SN75LVDS83(negative edge sampling). The first LVDS port(RxOxxx) transmits odd pixels while the second LVDS port(RxExxx) transmits even pixels.

PIN #	SIGNAL NAME	DESCRIPTION
1	RxOIN0-	Negative LVDS differential data input (Odd data)
2	RxOIN0+	Positive LVDS differential data input (Odd data)
3	RxOIN1-	Negative LVDS differential data input (Odd data)
4	RxOIN1+	Positive LVDS differential data input (Odd data)
5	RxOIN2-	Negative LVDS differential data input (Odd data, DSPTMG)
6	RxOIN2+	Positive LVDS differential data input (Odd data, DSPTMG)
7	GND	Power Ground
8	RxOCLK-	Negative LVDS differential clock input (Odd clock)
9	RxOCLK+	Positive LVDS differential clock input (Odd clock)
10	RxOIN3-	Negative LVDS differential data input (Odd data)
11	RxOIN3+	Positive LVDS differential data input (Odd data)
12	RxEIN0-	Negative LVDS differential data input (Even data)
13	RxEIN0+	Positive LVDS differential data input (Even data)
14	GND	Power Ground
15	RxEIN1-	Negative LVDS differential data input (Even data)
16	RxEIN1+	Positive LVDS differential data input (Even data)
17	GND	Power Ground
18	RxEIN2-	Negative LVDS differential data input (Even data)
19	RxEIN2+	Positive LVDS differential data input (Even data)
20	RxECLK-	Negative LVDS differential clock input (Even clock)
21	RxECLK+	Positive LVDS differential clock input (Even clock)
22	RxEIN3-	Negative LVDS differential data input (Even data)
23	RxEIN3+	Positive LVDS differential data input (Even data)
24	GND	Power Ground
25	NC	No connection (for AUO test only. Do not connect)
26	NC	No connection (for AUO test only. Do not connect)
27	NC	No connection (for AUO test only. Do not connect)
28	VDD	Power +5V
29	VDD	Power +5V
30	VDD	Power +5V

**Note1:** Start from left side



# Product Specification

M215HW02 V0

AU OPTRONICS CORPORATION

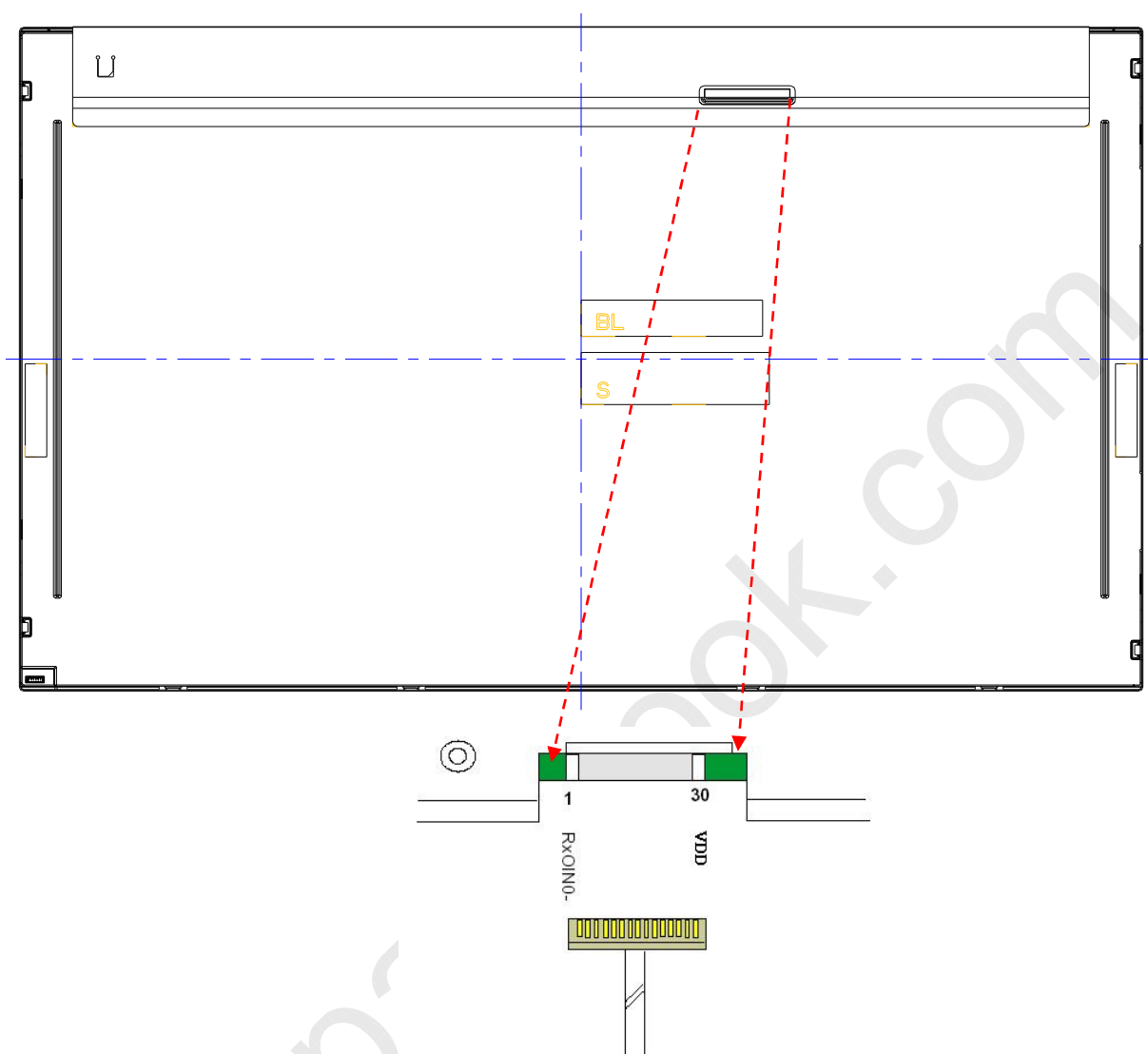

**Note2:** Input signals of odd and even clock shall be the same timing.



# Product Specification

M215HW02 V0

AU OPTRONICS CORPORATION

## 6.4 Timing Characteristics

Basically, interface timing described here is not actual input timing of LCD module but close to output timing of SN75LVDS82DGG (Texas Instruments) or equivalent.

Item	Symbol	Min	Typ	Max	Unit	
Data CLK	Tclk	40	72	83	[MHz]	
H-section	Period	Th	1004	1050	2047	[Tclk]
	Display Area	Tdisp(h)	960	960	960	[Tclk]
	Blanking	Tblk(h)	44	90	1087	[Tclk]
V-section	Period	Tv	1088	1130	2047	[Th]
	Display Area	Tdisp(h)	1080	1080	1080	[Th]
	Blanking	Tblk(h)	8	50	967	[Th]
Frame Rate	F	50	60	75	[Hz]	

**Note :** DE mode only



# Product Specification

M215HW02 V0

AU OPTRONICS CORPORATION

## 6.5 Timing diagram

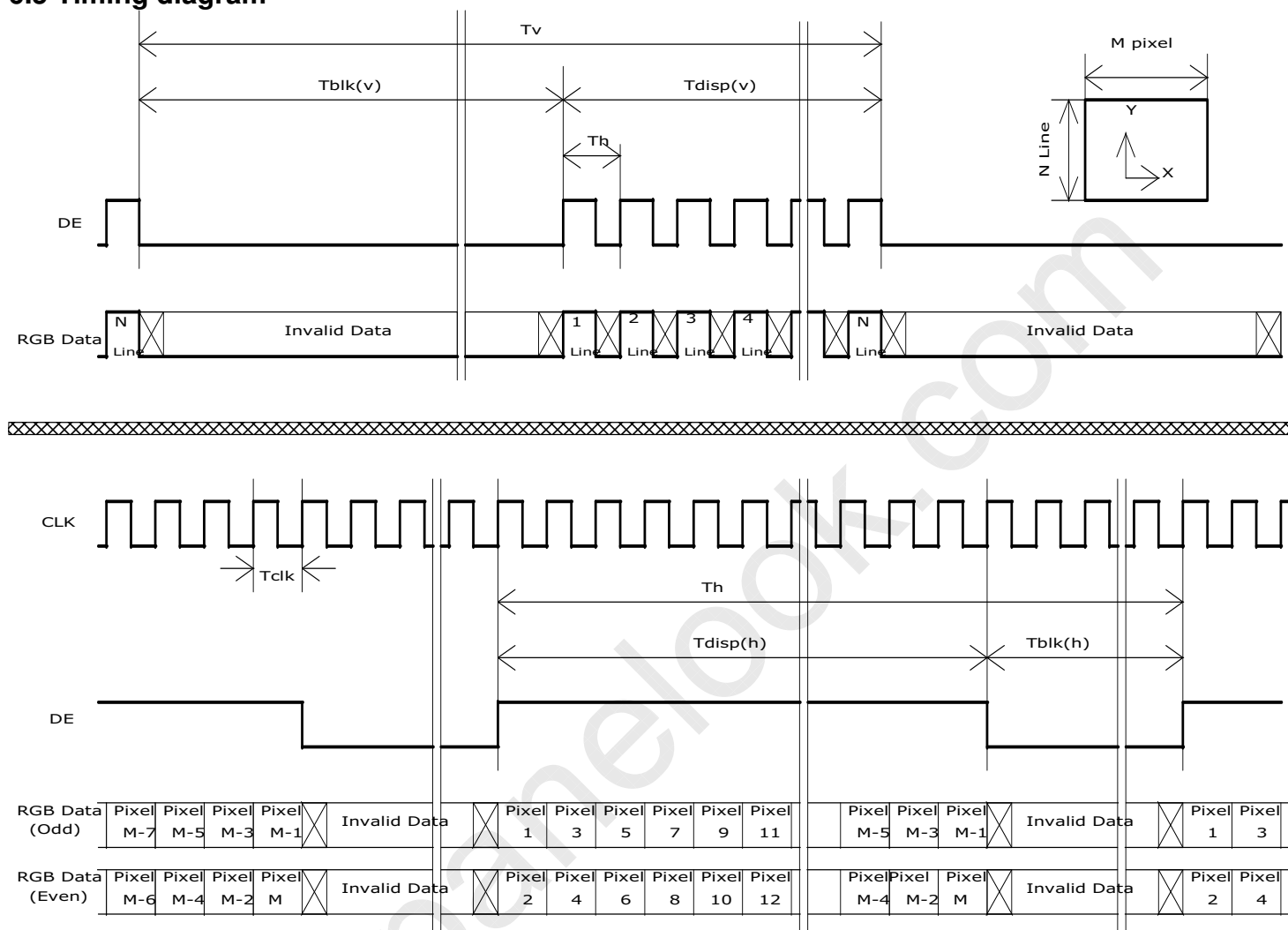





# Product Specification

M215HW02 V0

AU OPTRONICS CORPORATION

## 6.6 Power ON/OFF Sequence

VDD power and lamp on/off sequence are as follows. Interface signals are also shown in the chart. Signals from any system shall be Hi-Z state or low level when VDD is off.

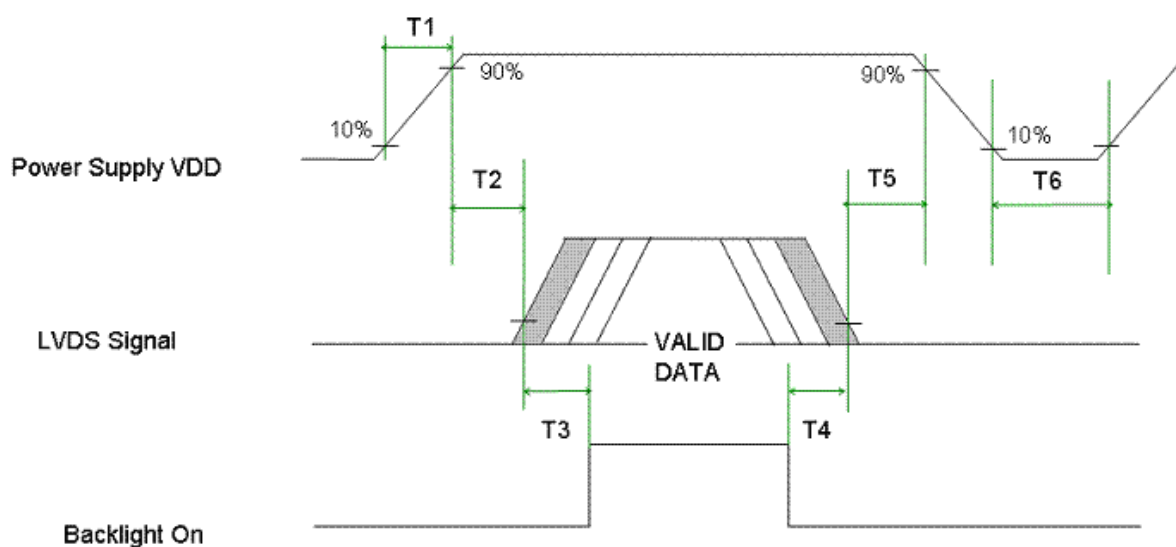

Parameter	Value		Unit
	Min.	Max.	
T1	0.5	10	[msec]
T2	0	50	[msec]
T3	500	-	[msec]
T4	200	-	[msec]
T5	0	50	[msec]
T6	1000	-	[msec]



# Product Specification

M215HW02 V0

AU OPTRONICS CORPORATION

## 7.0 Connector & Pin Assignment

Physical interface is described as for the connector on module. These connectors are capable of accommodating the following signals and will be following components.

### 7.1 TFT LCD Module

Connector Name / Designation	Interface Connector / Interface card
Manufacturer	JAE P-TWO
Type Part Number	FI-XPB30SRLA-HF11 01-187121-30091-3
Mating Housing Part Number	FI-X30HL (Locked Type)

#### 7.1.1 Pin Assignment

Pin#	Signal Name	Pin#	Signal Name
1	RxOIN0-	2	RxOIN0+
3	RxOIN1-	4	RxOIN1+
5	RxOIN2-	6	RxOIN2+
7	GND	8	RxOCLKIN-
9	RxOCLKIN+	10	RxOIN3-
11	RxOIN3+	12	RxEIN0-
13	RxEIN0+	14	GND
15	RxEIN1-	16	RxEIN1+
17	GND	18	RxEIN2-
19	RxEIN2+	20	RxECLKIN-
21	RxECLKIN+	22	RxEIN3-
23	RxEIN3+	24	GND
25	NC (for AUO test only. Do not connect)	26	NC (for AUO test only. Do not connect)
27	NC (for AUO test only. Do not connect)	28	VDD
29	VDD	30	VDD



# Product Specification

M215HW02 V0

AU OPTRONICS CORPORATION

## 7.2 Connector on Backlight Unit.

This connector is mounted on LED light-bar.

Connector Name / Designation	Light Bar Connector
Manufacturer	CVILUX CORPORATION
Type Part Number	CI1406M1HRC-NH

### 7.2.1 Pin assignment

Pin no.	Signal name
1	IRLED (current out)
2	IRLED (current out)
3	VLED (voltage in)
4	VLED (voltage in)
5	IRLED (current out)
6	IRLED (current out)



# Product Specification

M215HW02 V0

AU OPTRONICS CORPORATION

## 8.0 Reliability Test

Environment test conditions are listed as following table.

Items	Required Condition	Note
Temperature Humidity Bias (THB)	Ta= 50°C, 80%RH, 300hours	
High Temperature Operation (HTO)	Ta= 50°C, 50%RH, 300hours	
Low Temperature Operation (LTO)	Ta= 0°C, 300hours	
High Temperature Storage (HTS)	Ta= 60°C, 300hours	
Low Temperature Storage (LTS)	Ta= -20°C, 300hours	
Vibration Test (Non-operation)	Acceleration: 1.5 Grms Wave: Random Frequency: 10 - 200 Hz	
Shock Test (Non-operation)	Acceleration: 50 G Wave: Half-sine Active Time: 20 ms	
Drop Test	Height: 46 cm, package test	
Thermal Shock Test (TST)	-20°C/30min, 60°C/30min, 100 cycles	<b>1</b>
On/Off Test	On/10sec, Off/10sec, 30,000 cycles	
ESD (Electro Static Discharge)	Contact Discharge: ± 8KV, 150pF(330Ω) 1sec, 15 points, 25 times/ point.	<b>2</b>
	Air Discharge: ± 15KV, 150pF(330Ω) 1sec 15 points, 25 times/ point.	
Altitude Test	Operation:10,000 ft Non-Operation:30,000 ft	

**Note 1:** The TFT-LCD module will not sustain damage after being subjected to 100 cycles of rapid temperature change. A cycle of rapid temperature change consists of varying the temperature from -20°C to 60°C, and back again. Power is not applied during the test. After temperature cycling, the unit is placed in normal room ambient for at least 4 hours before power on.

**Note 2:** EN61000-4-2, ESD class B: Certain performance degradation allowed  
 No data lost  
 Self-recoverable  
 No hardware failures.



# Product Specification

M215HW02 V0

AU OPTRONICS CORPORATION

## 9.0 Shipping Label

The label is on the panel as shown below:

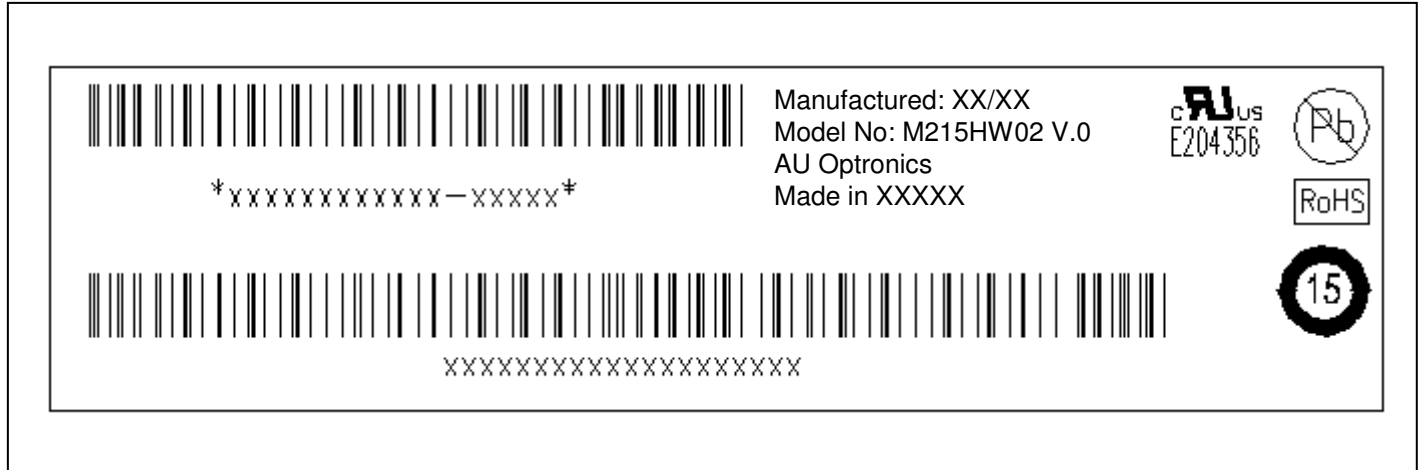

**Note 1:** For Pb Free products, AUO will add  for identification.

**Note 2:** For RoHS compatible products, AUO will add  for identification.

**Note 3:** For China RoHS compatible products, AUO will add  for identification.

**Note 4:** The Green Mark will be presented only when the green documents have been ready by AUO Internal Green Team.

### 10.0 Mechanical Characteristics

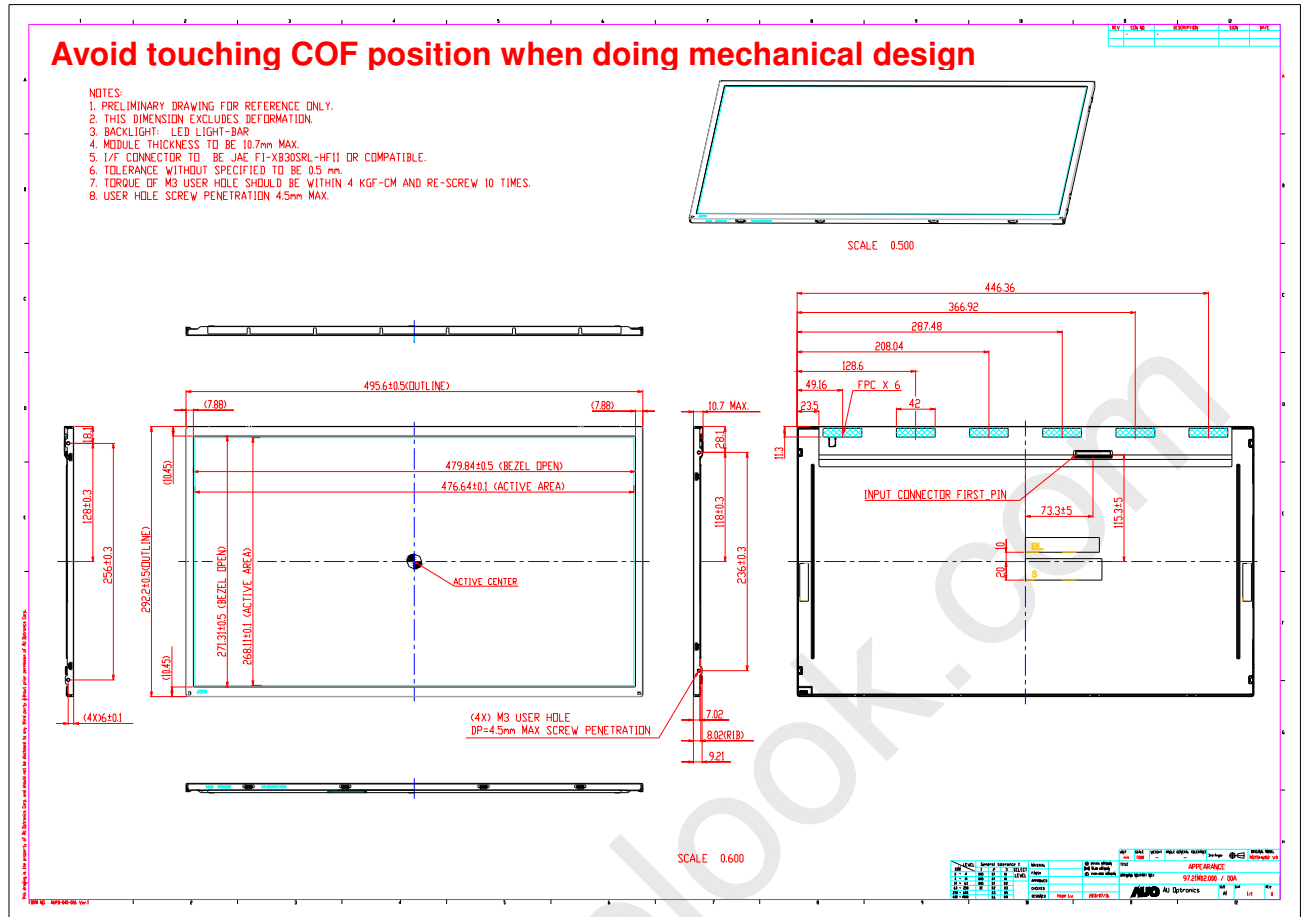



# Product Specification

M215HW02 V0

AU OPTRONICS CORPORATION

## 11.0 Packing Specification

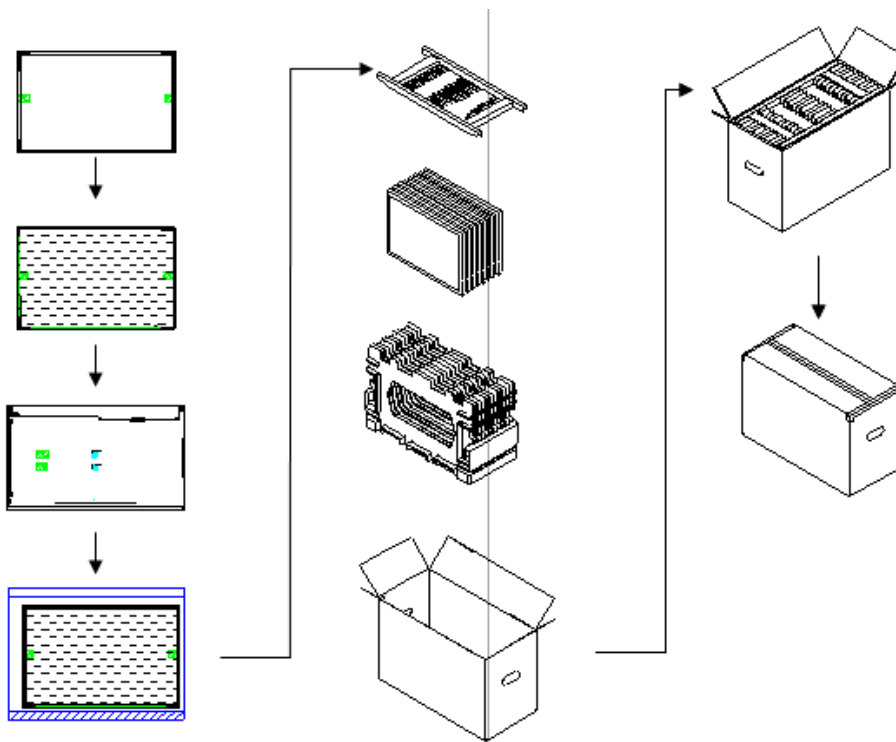

## Pallet and shipment information

	Item	Specification			Remark
		Q'ty	Dimension (mm)	Weight(kg)	
1	Panel	1	459.6(H) x 292.2(V) x 10.7(D)	1.8	
2	Cushion	1	-	1.11	
3	Box	1	568(L)mm x 277(W)mm x 382(H)mm	1.035	without Panel & cushion
4	Packing Box	10 pcs/Box	568(L)mm x 277(W)mm x 382(H)mm	19.6	with panel & cushion
5	Pallet	1	1150(L)mm x 840(W)mm x 138(H)mm	12	
6	Pallet after Packing	18 boxes/pallet	1150(L)mm x 840(W)mm x 128.6(H)mm	365.6	