



Product Specification

M215HW03 V2

AU OPTRONICS CORPORATION

() Preliminary Specification
(V) Final Specification

| | |
|------------|---------------------|
| Module | 21.5" Color TFT-LCD |
| Model Name | M215HW03 V2 |

| | |
|----------------------------------------------------------------------------------------------------------------|---------------------------------------------------------------------------------------------------------------------------------------------------------------------------------------------------------------------------------------------------------------------------|
| <p>Customer Date</p> <p>_____</p> <p>Approved by</p> <p>_____</p> | <p>Approved by Date</p> <p><u>Paul Huang</u> <u>Nov 17, 2011</u></p> <p>Prepared by Date</p> <p><u>Steven Su</u> <u>Nov 17, 2011</u></p> |
| <p>Note: This Specification is subject to change without notice.</p> | <p>Desktop Display Business Group / AU Optronics corporation</p> |



Product Specification

M215HW03 V2

AU OPTRONICS CORPORATION

Contents

| | |
|-------------------------------------------------|-----------|
| 1.0 Handling Precautions..... | 4 |
| 2.0 General Description | 5 |
| 2.1 Display Characteristics..... | 5 |
| 2.2 Optical Characteristics | 6 |
| 3.0 Functional Block Diagram | 10 |
| 4.0 Absolute Maximum Ratings | 11 |
| 4.1 TFT LCD Module..... | 11 |
| 4.2 Absolute Ratings of Environment..... | 11 |
| 5.0 Electrical characteristics..... | 12 |
| 5.1 TFT LCD Module..... | 12 |
| 5.1.1 Power Specification | 12 |
| 5.1.2 Signal Electrical Characteristics | 13 |
| 6.0 Signal Characteristic..... | 16 |
| 6.1 Pixel Format Image..... | 16 |
| 6.2 The input data format | 16 |
| 6.3 Signal Description..... | 17 |
| 6.4 Timing Characteristics | 19 |
| 6.5 Timing diagram..... | 20 |
| 6.6 Power ON/OFF Sequence | 21 |
| 7.0 Connector & Pin Assignment | 22 |
| 7.1 TFT LCD Module..... | 22 |
| 7.1.1 Pin Assignment | 22 |
| 7.2 Connector on Backlight Unit..... | 23 |
| 7.2.1 Signal for LED light bar connector..... | 23 |
| 8.0 Reliability Test..... | 24 |
| 9.0 Shipping Label | 25 |
| 10.0 Mechanical Characteristics | 26 |
| 11. Packing Specification..... | 28 |



Product Specification

M215HW03 V2

AU OPTRONICS CORPORATION

Record of Revision

| Version and Date | Page | Old description | New Description | Remark |
|------------------|------|--------------------------------------------------|--------------------------------------------------|---------|
| 0.1 2011/5/5 | All | First Edition for Customer | - | |
| 1.0 2011/7/7 | All | Final Spec. | | |
| 1.1 2011/7/20 | 19 | Data clock max=90MHz | Data clock max=94MHz | Revised |
| 1.1 2011/7/20 | 26 | Mechanical Characteristics Thickness 10.3±0.5 | Mechanical Characteristics Thickness 10.5±0.5 | Revised |
| 1.2 2011/11/17 | 27 | Mechanical Characteristics | Modify label position | Revised |
| | | | | |
| | | | | |
| | | | | |
| | | | | |
| | | | | |
| | | | | |
| | | | | |
| | | | | |
| | | | | |
| | | | | |
| | | | | |
| | | | | |



1.0 Handling Precautions

- 1) Since front polarizer is easily damaged, pay attention not to scratch it.
- 2) Be sure to turn off power supply when inserting or disconnecting from input connector.
- 3) Wipe off water drop immediately. Long contact with water may cause discoloration or spots.
- 4) When the panel surface is soiled, wipe it with absorbent cotton or other soft cloth.
- 5) Since the panel is made of glass, it may break or crack if dropped or bumped on hard surface.
- 6) Since CMOS LSI is used in this module, take care of static electricity and insure human earth when handling.
- 7) Do not open or modify the Module Assembly.
- 8) Do not press the reflector sheet at the back of the module to any directions.
- 9) In case if a Module has to be put back into the packing container slot after once it was taken out from the container, do not press the center of the LED lightbar edge. Instead, press at the far ends of the LED light bar edge softly. Otherwise the TFT Module may be damaged.
- 10) At the insertion or removal of the Signal Interface Connector, be sure not to rotate nor tilt the Interface Connector of the TFT Module.
- 11) After installation of the TFT Module into an enclosure, do not twist nor bend the TFT Module even momentary. At designing the enclosure, it should be taken into consideration that no bending/twisting forces are applied to the TFT Module from outside. Otherwise the TFT Module may be damaged.
- 12) Small amount of materials having no flammability grade is used in the LCD module. The LCD module should be supplied by power complied with requirements of Limited Power Source (IEC60950 or UL1950), or be applied exemption.
- 13) Pls avoid touching COF position while you are doing mechanical design.
- 14) When storing modules as spares for a long time, the following precaution is necessary:
Store them in a dark place. Do not expose the module to sunlight or fluorescent light. Keep the temperature between 5°C and 35°C at normal humidity.



Product Specification

M215HW03 V2

AU OPTRONICS CORPORATION

2.0 General Description

This specification applies to the 21.5 inch-wide Color a-Si TFT-LCD Module M215HW03. The display supports the Full HD - 1920(H) x 1080(V) screen format and 16.7M colors (RGB 6-bits + Hi-FRC data). All input signals are 2-channel LVDS interface and this module doesn't contain an driver board for backlight.

2.1 Display Characteristics

The following items are characteristics summary on the table under 25□ condition:

| ITEMS | Unit | SPECIFICATIONS |
|-----------------------------------------|----------------------|--------------------------------------------------------|
| Screen Diagonal | [mm] | 546.86(21.53") |
| Active Area | [mm] | 476.64 (H) x 268.11 (V) |
| Pixels H x V | | 1920(x3) x 1080 |
| Pixel Pitch | [um] | 248.25 (per one triad) x248.25 |
| Pixel Arrangement | | R.G.B. Vertical Stripe |
| Display Mode | | TN Mode, Normally White |
| White Luminance (Center) | [cd/m ²] | 250cd/m ² (Typ.) |
| Contrast Ratio | | 1000 (Typ.) |
| Optical Response Time | [msec] | 5ms (Typ., on/off) |
| Nominal Input Voltage VDD | [Volt] | +5.0 V |
| Power Consumption (VDD line + LED line) | [Watt] | 17 (Typ.) (without driver board, all black pattern) |
| Weight | [Grams] | 1750 |
| Physical Size | [mm] | 495.6(W) x 292.2(H) x 10.5(D) Typ. |
| Electrical Interface | | Dual channel LVDS |
| Support Color | | 16.7M colors (RGB 6-bit + Hi_FRC) |
| Surface Treatment | | Glare, 3H |
| Temperature Range | | |
| Operating | [°C] | 0 to +50 |
| Storage (Shipping) | [°C] | -20 to +60 |
| RoHS Compliance | | RoHS Compliance |
| TCO Compliance | | TCO Compliance |



Product Specification

M215HW03 V2

AU OPTRONICS CORPORATION

2.2 Optical Characteristics

The optical characteristics are measured under stable conditions at 25□:

| Item | Unit | Conditions | Min. | Typ. | Max. | Note |
|----------------------------------------|----------------------|--------------------------------------|----------|----------|--------|------|
| Viewing Angle | [degree] | Horizontal (Right) CR = 10 (Left) | 75 75 | 85 85 | - - | 2 |
| | | Vertical (Up) CR = 10 (Down) | 70 70 | 80 80 | - - | |
| Contrast ratio | | Normal Direction | 600 | 1000 | - | 3 |
| Response Time | [msec] | Raising Time (T _{RR}) | - | 3.8 | 5.5 | 4 |
| | | Falling Time (T _{RF}) | - | 1.2 | 2.5 | |
| | | Raising + Falling | - | 5 | 8 | |
| Color / Chromaticity Coordinates (CIE) | | Red x | 0.616 | 0.646 | 0.676 | 5 |
| | | Red y | 0.302 | 0.332 | 0.362 | |
| | | Green x | 0.301 | 0.331 | 0.361 | |
| | | Green y | 0.595 | 0.625 | 0.655 | |
| | | Blue x | 0.126 | 0.156 | 0.186 | |
| | | Blue y | 0.021 | 0.051 | 0.081 | |
| Color Coordinates (CIE) White | | White x | 0.283 | 0.313 | 0.343 | |
| | | White y | 0.299 | 0.329 | 0.359 | |
| Central Luminance | [cd/m ²] | | 200 | 250 | - | 6 |
| Luminance Uniformity | [%] | | 75 | 80 | - | 7 |
| Crosstalk (in 60Hz) | [%] | | | | 1.5 | 8 |
| Flicker | dB | | | | -20 | 9 |



Product Specification

M215HW03 V2

AU OPTRONICS CORPORATION

Note 1: Measurement method

The LCD module should be stabilized at given temperature for 30 minutes to avoid abrupt temperature change during measuring (at surface 35°C). In order to stabilize the luminance, the measurement should be executed after lighting Backlight for 30 minutes in a stable, windless and dark room.

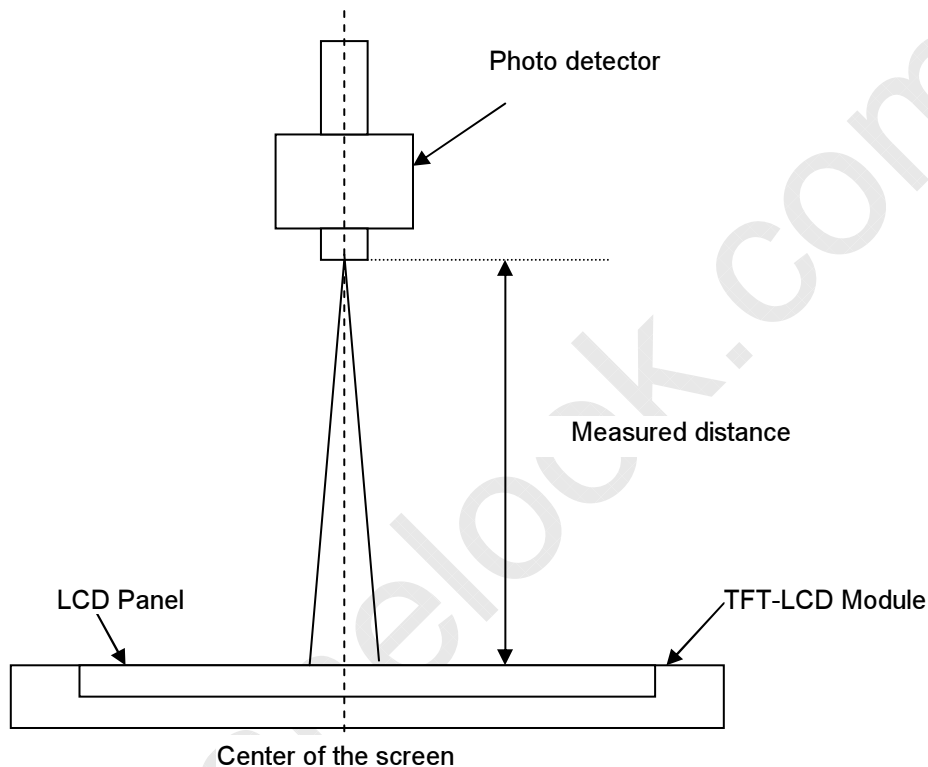

Note 2: Definition of viewing angle measured by ELDIM (EZContrast 88)

Viewing angle is the measurement of contrast ratio ≥ 10 , at the screen center, over a 180° horizontal and 180° vertical range (off-normal viewing angles). The 180° viewing angle range is broken down as follows; 90° (θ) horizontal left and right and 90° (ϕ) vertical, high (up) and low (down). The measurement direction is typically perpendicular to the display surface with the screen rotated about its center to develop the desired measurement viewing angle.

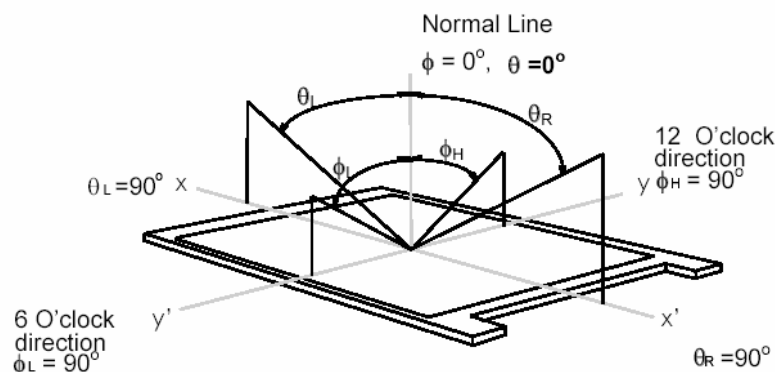



Product Specification

M215HW03 V2

AU OPTRONICS CORPORATION

Note 3: Contrast ratio is measured by TOPCON SR-3

Note 4: Definition of Response time measured by Westar TRD-100A

The output signals of photo detector are measured when the input signals are changed from “Full Black” to “Full White” (rising time, T_{rR}), and from “Full White” to “Full Black” (falling time, T_{rF}), respectively. The response time is interval between the 10% and 90% (1 frame at 60 Hz) of amplitudes.

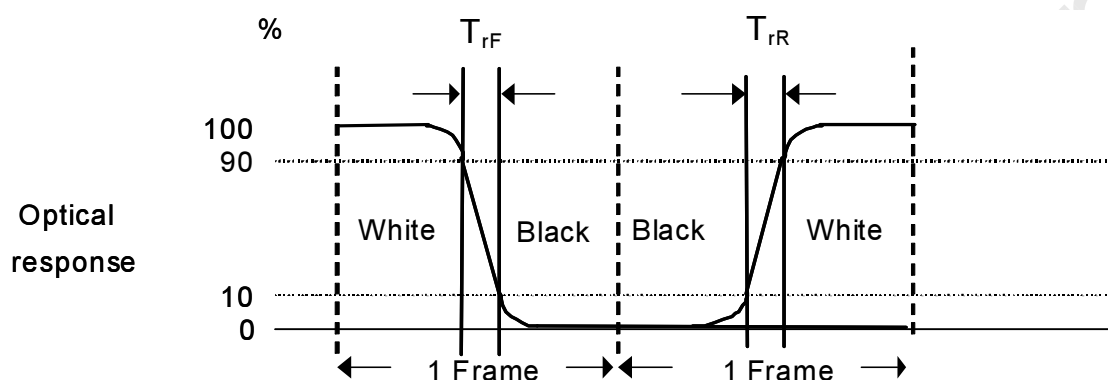

$T_{rR} + T_{rF} = 5 \text{ msec (typ.)}$.

Note 5: Color chromaticity and coordinates (CIE) is measured by TOPCON SR-3

Note 6: Central luminance is measured by TOPCON SR-3

Note 7: Luminance uniformity of these 9 points is defined as below and measured by TOPCON SR-3

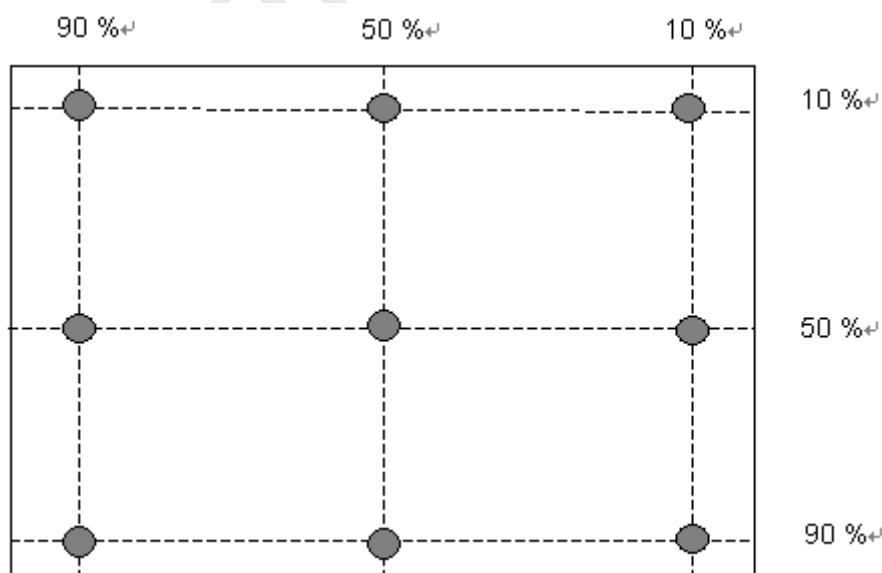

$$\text{Uniformity} = \frac{\text{Minimum Luminance in 9 points (1-9)}}{\text{Maximum Luminance in 9 Points (1-9)}}$$



Product Specification

M215HW03 V2

AU OPTRONICS CORPORATION

Note 8: Crosstalk is defined as below and measured by TOPCON SR-3

$$CT = |YB - YA| / YA \times 100 (\%)$$

Where

YA = Luminance of measured location without gray level 0 pattern (cd/m2)

YB = Luminance of measured location with gray level 0 pattern (cd/m2)

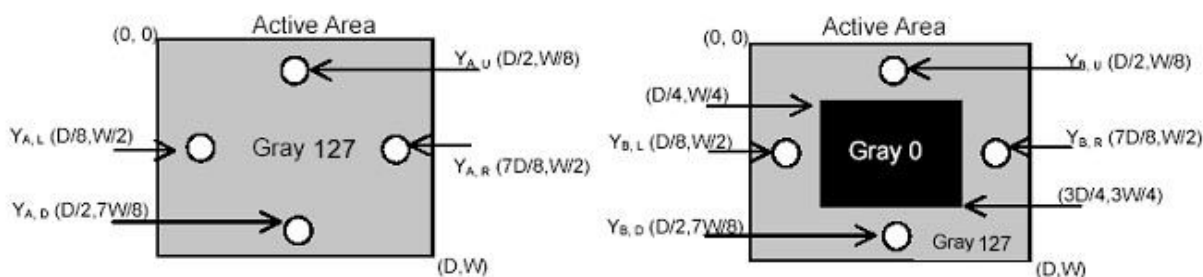

Note 9: Test Pattern: Subchecker Pattern measured by TOPCON SR-3

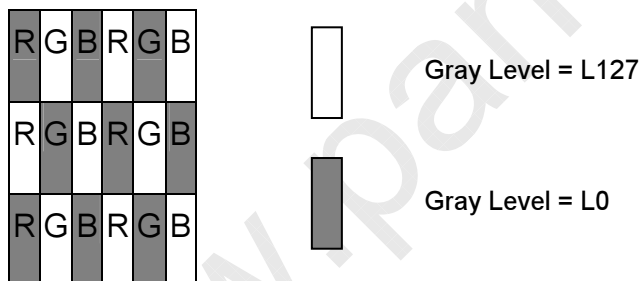

Method: Record dBV & DC value with TRD-100

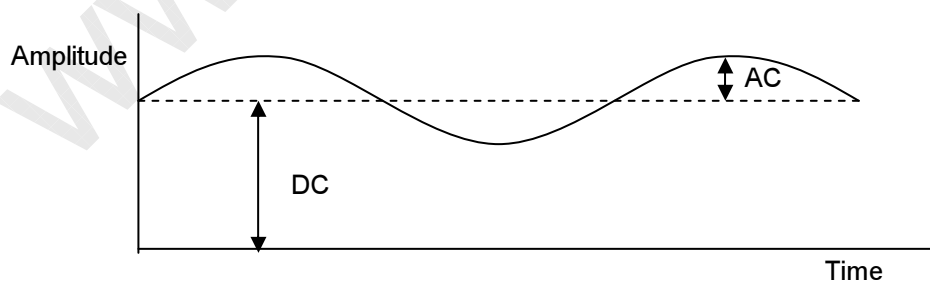

$$\text{Flicker (dB)} = 20 \log \frac{\text{AC Level(at 30 Hz)}}{\text{DC Level}}$$



Product Specification

M215HW03 V2

AU OPTRONICS CORPORATION

3.0 Functional Block Diagram

The following diagram shows the functional block of the 21.5 inch Color TFT-LCD Module:

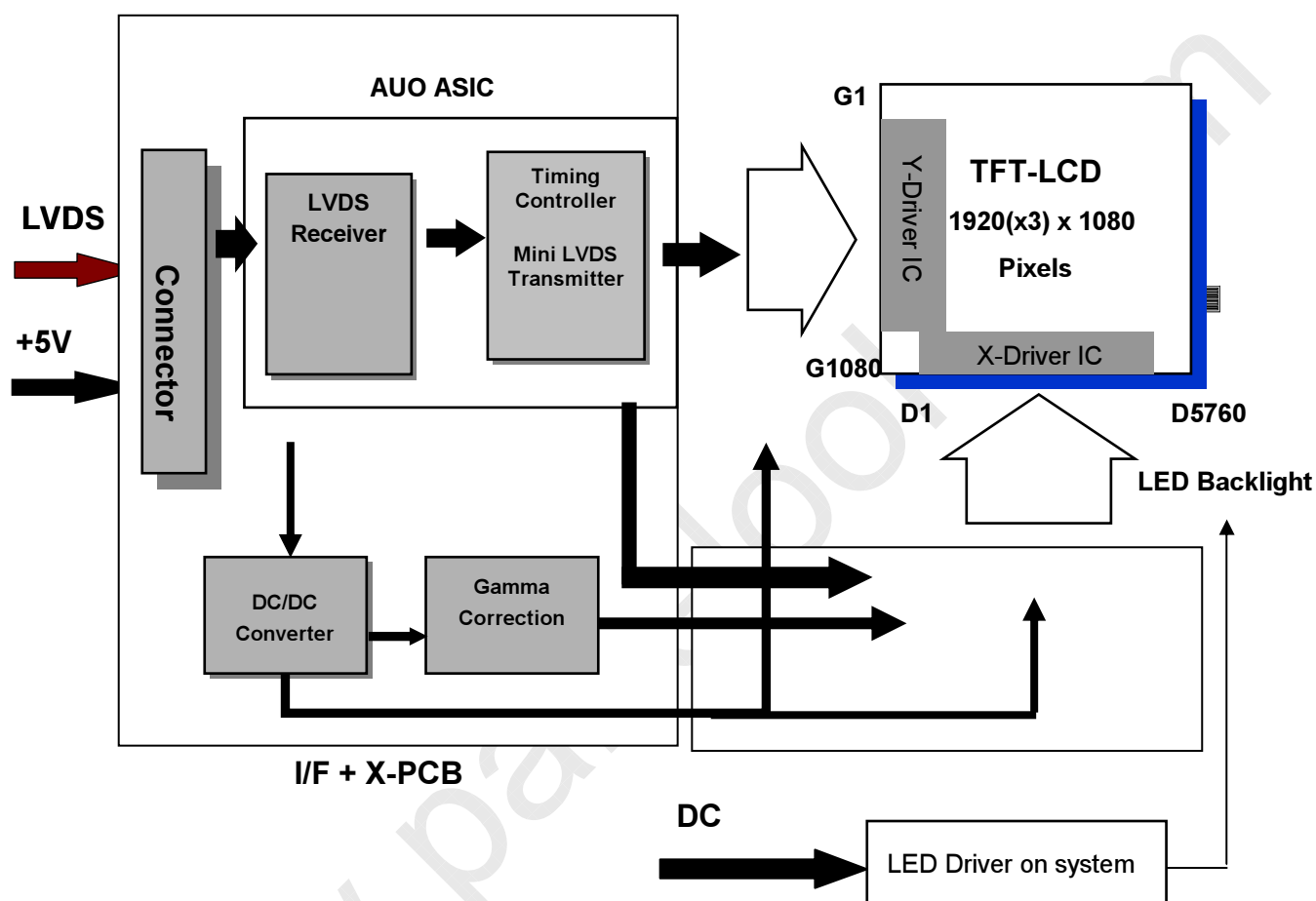

I/F PCB Interface:

JAE-FI-XPB30SRLA-HF11

P-TWO-187121-30091-3(A)

Mating Type:

FI-X30HL (Locked Type)



Product Specification

M215HW03 V2

AU OPTRONICS CORPORATION

4.0 Absolute Maximum Ratings

Absolute maximum ratings of the module are as following:

4.1 TFT LCD Module

| Item | Symbol | Min | Max | Unit | Conditions |
|-------------------------|--------|-----|-----|--------|-----------------|
| Logic/LCD Drive Voltage | VDD | 0 | 6.0 | [Volt] | Note 1,2 |

4.2 Absolute Ratings of Environment

| Item | Symbol | Min. | Max. | Unit | Conditions |
|---------------------------------------|--------|------|------|-------|-----------------------|
| Operating Temperature | TOP | 0 | +50 | [°C] | Note 3 |
| Glass surface temperature (operation) | TGS | 0 | +65 | [°C] | Note 3, Note 4 |
| Operation Humidity | HOP | 5 | 90 | [%RH] | Note 3 |
| Storage Temperature | TST | -20 | +60 | [°C] | |
| Storage Humidity | HST | 5 | 90 | [%RH] | |

Note 1: With in Ta (25°C)

Note 2: Permanent damage to the device may occur if exceeding maximum values

Note 3: Temperature and relative humidity range are shown as the below figure.

1. 90% RH Max (Ta ≤39°C)
2. Max wet-bulb temperature at 39°C or less. (Ta ≤39°C)
3. No condensation

Note 4: Function Judged only

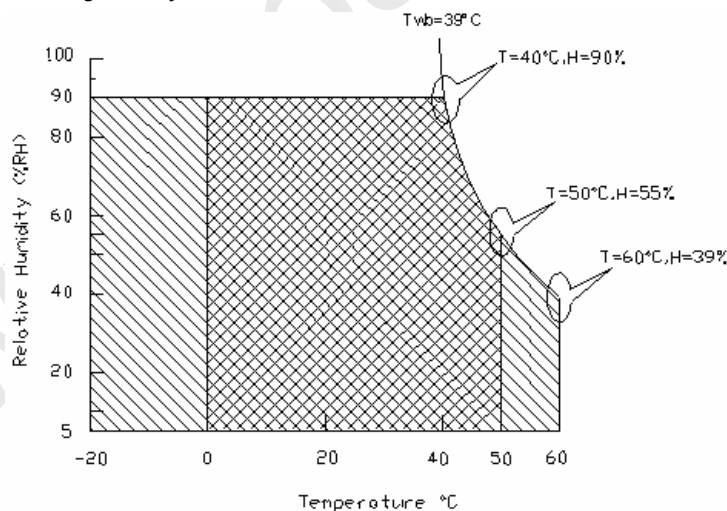

Operating Range



Storage Range

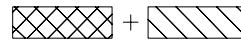



Product Specification

M215HW03 V2

AU OPTRONICS CORPORATION

5.0 Electrical characteristics

5.1 TFT LCD Module

5.1.1 Power Specification

Input power specifications are as following:

| Symbol | Parameter | Min | Typ | Max | Unit | Conditions |
|-------------------|------------------------------------------|-----|------|------|----------|-----------------------------------------|
| VDD | Logic/LCD Drive Voltage | 4.5 | 5.0 | 5.5 | [Volt] | +/-10% |
| IDD | Input Current | - | 0.82 | 0.98 | [A] | VDD= 5.0V, All Black Pattern At 60Hz |
| | | - | 0.92 | 1.1 | [A] | VDD= 5.0V, All Black Pattern At 75Hz |
| PDD | VDD Power | - | 4.1 | 4.9 | [Watt] | VDD= 5.0V, All Black Pattern At 60Hz |
| | | - | 4.6 | 5.5 | [Watt] | VDD= 5.0V, All Black Pattern At 75Hz |
| IRush | Inrush Current | - | - | 3 | [A] | Note 1 |
| VDD _{rp} | Allowable Logic/LCD Drive Ripple Voltage | - | - | 500 | [mV] p-p | VDD= 5.0V, All Black Pattern At 75Hz |

Note 1: Measurement conditions:

The duration of rising time of power input is 470us.

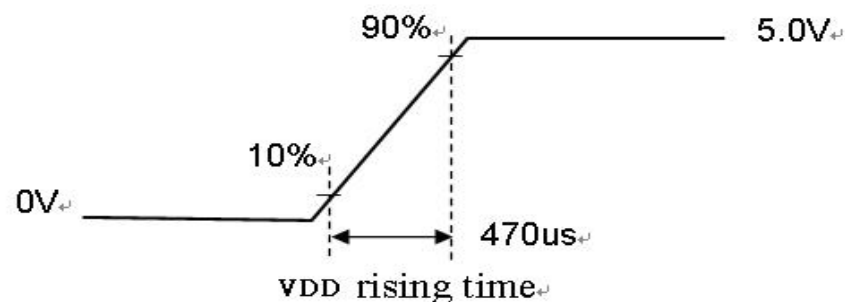
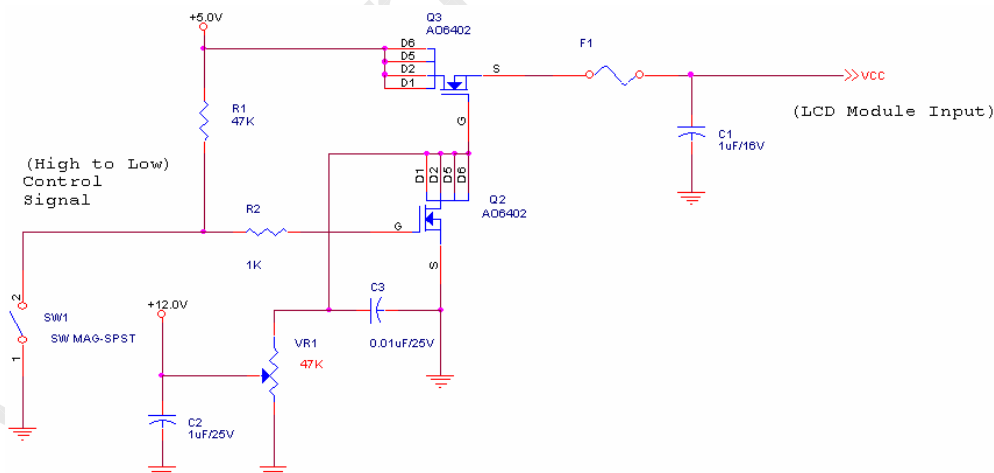



Product Specification

M215HW03 V2

AU OPTRONICS CORPORATION

5.1.2 Signal Electrical Characteristics

Input signals shall be low or Hi-Z state when VDD is off. Please refer to specifications of SN75LVDS82DGG (Texas Instruments) in detail.

1. DC Characteristics of each signal are as following:

| Symbol | Parameter | Min | Typ | Max | Units | Condition |
|------------------|----------------------------------------|------|------|------|-------|-----------------------------------------------------------------|
| V _{TH} | Differential Input High Threshold | - | - | +100 | [mV] | V _{ICM} = 1.2V Note 1 |
| V _{TL} | Differential Input Low Threshold | -100 | - | - | [mV] | V _{ICM} = 1.2V Note 1 |
| V _{ID} | Input Differential Voltage | 100 | - | 600 | [mV] | Note 1 |
| V _{ICM} | Differential Input Common Mode Voltage | +1.0 | +1.2 | +1.5 | [V] | V _{TH} -V _{TL} = 200mV (max) Note 1 |

Note 1: LVDS Signal Waveform

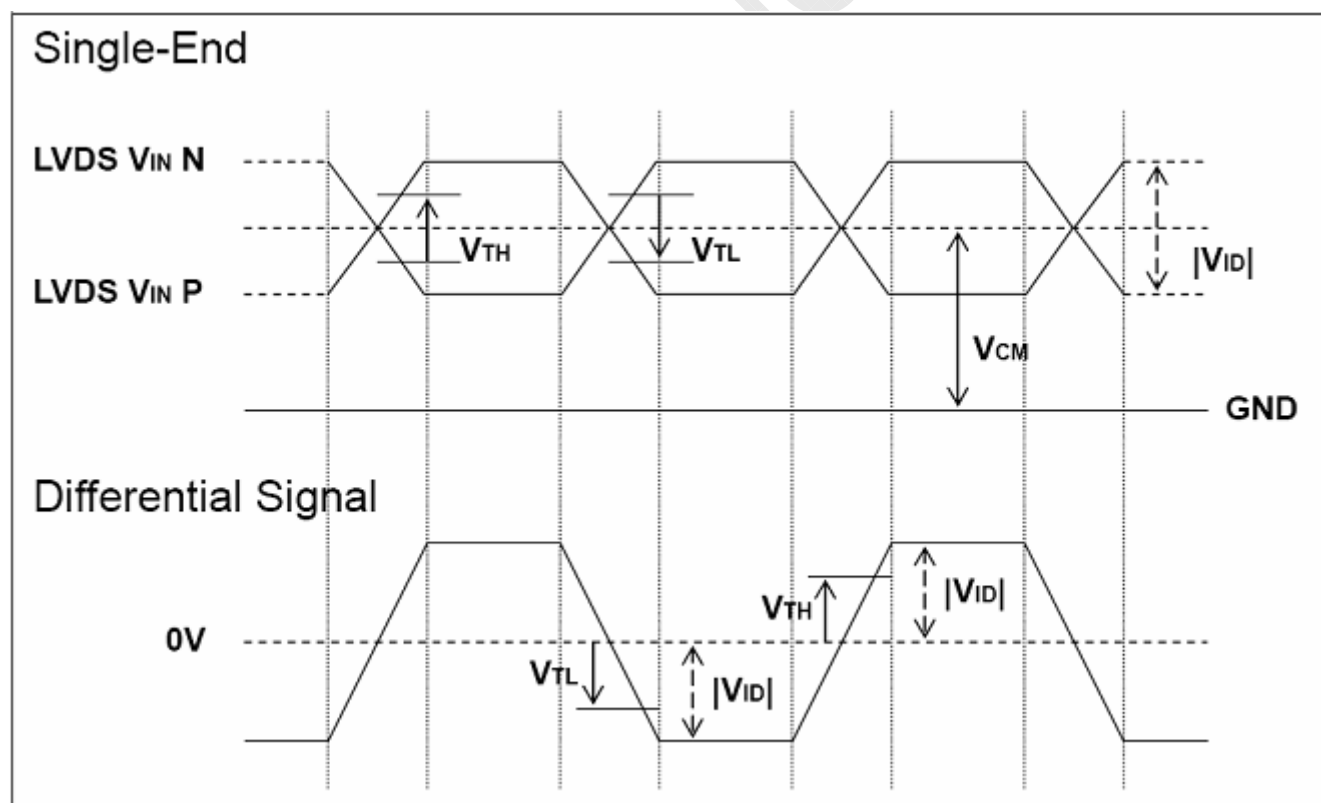



Product Specification

M215HW03 V2

AU OPTRONICS CORPORATION

2. AC Characteristics

| Description | Symbol | Min | Max | Unit | Note |
|--------------------------------------------------------|-----------|-----|---------|------|------|
| Maximum deviation of input clock frequency during SSC | F_{DEV} | - | ± 3 | % | |
| Maximum modulation frequency of input clock during SSC | F_{MOD} | - | 300 | KHz | |

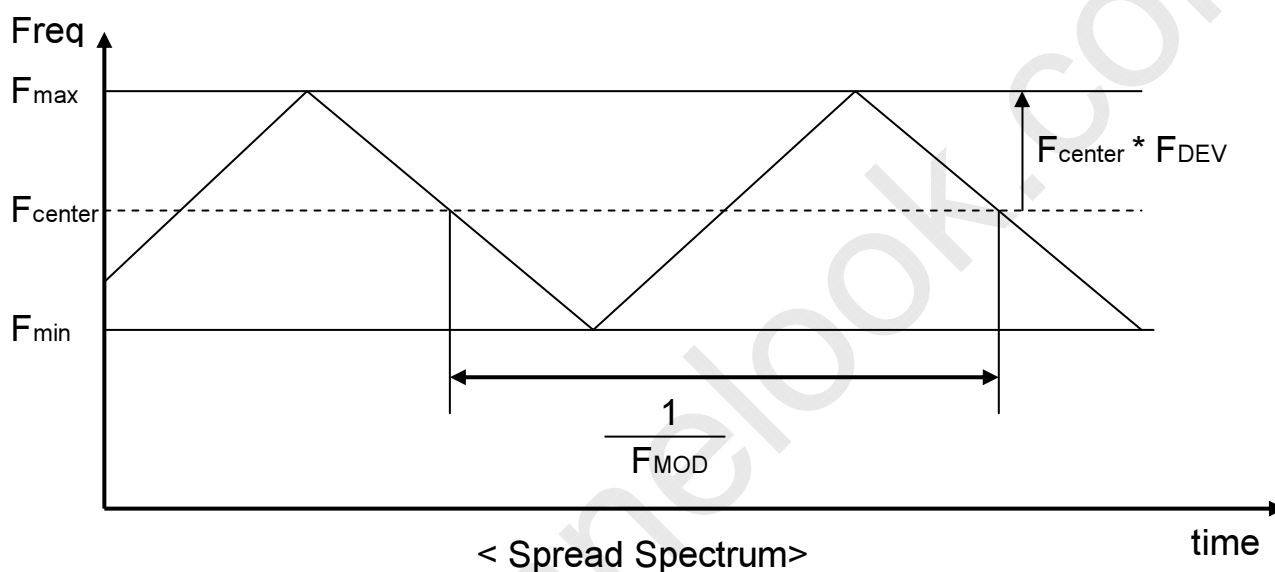



Product Specification

M215HW03 V2

AU OPTRONICS CORPORATION

5.2 Backlight Unit

Parameter guideline for LED driver is under stable conditions at 25□(Room Temperature):

| Symbol | Parameter | Min.□ | Typ. | Max. | Unit | Note |
|---------------|---------------------------------------------|-------|------|------|------------------|---------------------------------------------|
| $I_{R_{LED}}$ | LED Operation Current | - | 60 | 63 | [mA] Note 1 | Operating with fixed driving current |
| V_{LB} | Light Bar Operation Voltage (for reference) | 48 | 52.8 | 57.6 | [Volt] Note 2 | |
| P_{BLU} | BLU Power consumption (for reference) | | 12.7 | 13.8 | [Watt] Note 3 | |
| LT_{LED} | LED life Time | 30000 | | | [Hour] Note 3 | |

Note 1 :The specified current is input LED chip 100% duty current.

Note 2 : The value showed in the table is one light bar's operation voltage.

Note 3 : Definition of life time : brightness becomes 50% of its original value. The minimum life time of LED unit is on the condition of $I_{R_{LED}}=60mA$ and $25\pm 2^{\circ}C$ (Room temperature).

Note 4: Each LED light bar consists of 64 pcs LED package (4 strings x 16 pcs / string).



Product Specification

M215HW03 V2

AU OPTRONICS CORPORATION

6.0 Signal Characteristic

6.1 Pixel Format Image

Following figure shows the relationship of the input signals and LCD pixel format.

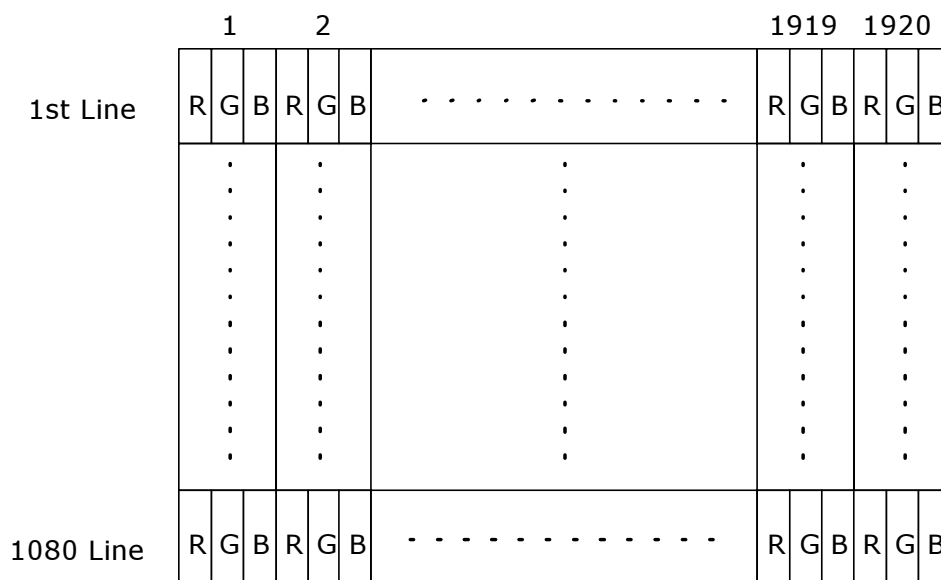

6.2 The input data format

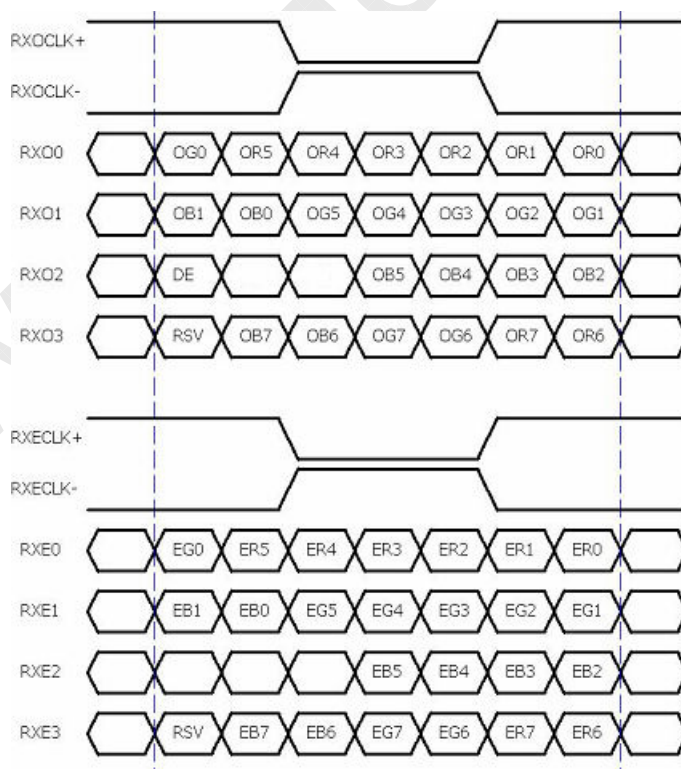

Note 1: R/G/B data 7:MSB, R/G/B data 0:LSB O = "First Pixel Data" E = "Second Pixel Data"



Product Specification

M215HW03 V2

AU OPTRONICS CORPORATION

6.3 Signal Description

The module using one LVDS receiver SN75LVDS82(Texas Instruments). LVDS is a differential signal technology for LCD interface and high speed data transfer device. LVDS transmitters shall be SN75LVDS83(negative edge sampling). The first LVDS port(RxOxxx) transmits odd pixels while the second LVDS port(RxExxx) transmits even pixels.

| PIN # | SIGNAL NAME | DESCRIPTION |
|-------|-------------|---------------------------------------------------------|
| 1 | RxOIN0- | Negative LVDS differential data input (Odd data) |
| 2 | RxOIN0+ | Positive LVDS differential data input (Odd data) |
| 3 | RxOIN1- | Negative LVDS differential data input (Odd data) |
| 4 | RxOIN1+ | Positive LVDS differential data input (Odd data) |
| 5 | RxOIN2- | Negative LVDS differential data input (Odd data,DSPTMG) |
| 6 | RxOIN2+ | Positive LVDS differential data input (Odd data,DSPTMG) |
| 7 | GND | Power Ground |
| 8 | RxOCLK- | Negative LVDS differential clock input (Odd clock) |
| 9 | RxOCLK+ | Positive LVDS differential clock input (Odd clock) |
| 10 | RxOIN3- | Negative LVDS differential data input (Odd data) |
| 11 | RxOIN3+ | Positive LVDS differential data input (Odd data) |
| 12 | RxEIN0- | Negative LVDS differential data input (Even data) |
| 13 | RxEIN0+ | Positive LVDS differential data input (Even data) |
| 14 | GND | Power Ground |
| 15 | RxEIN1- | Negative LVDS differential data input (Even data) |
| 16 | RxEIN1+ | Positive LVDS differential data input (Even data) |
| 17 | GND | Power Ground |
| 18 | RxEIN2- | Negative LVDS differential data input (Even data) |
| 19 | RxEIN2+ | Positive LVDS differential data input (Even data) |
| 20 | RxECLK- | Negative LVDS differential clock input (Even clock) |
| 21 | RxECLK+ | Positive LVDS differential clock input (Even clock) |
| 22 | RxEIN3- | Negative LVDS differential data input (Even data) |
| 23 | RxEIN3+ | Positive LVDS differential data input (Even data) |
| 24 | GND | Power Ground |
| 25 | NC | No connection (for AUO test only. Do not connect) |
| 26 | NC | No connection (for AUO test only. Do not connect) |
| 27 | NC | No connection (for AUO test only. Do not connect) |
| 28 | VDD | Power +5V |
| 29 | VDD | Power +5V |
| 30 | VDD | Power +5V |

Note1: Start from left side



Product Specification

M215HW03 V2

AU OPTRONICS CORPORATION

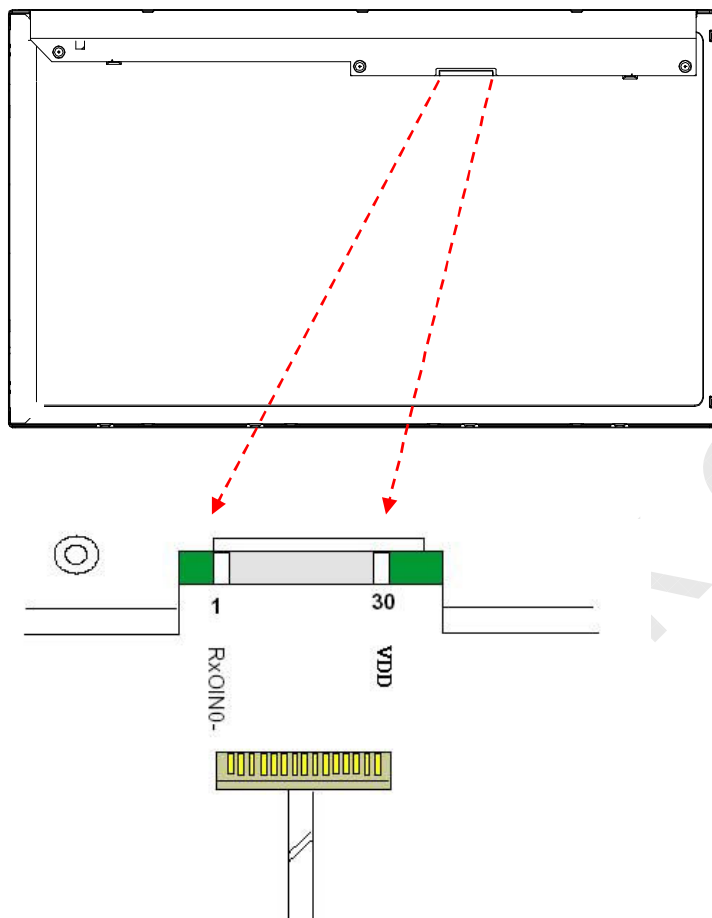

Note2: Input signals of odd and even clock shall be the same timing.



Product Specification

M215HW03 V2

AU OPTRONICS CORPORATION

6.4 Timing Characteristics

Basically, interface timing described here is not actual input timing of LCD module but close to output timing of SN75LVDS82DGG (Texas Instruments) or equivalent.

| Signal | Item | Symbol | Min | Typ | Max | Unit |
|--------------------|------------|-------------------------------|------|------|------|------|
| Vertical Section | Period | T_v | 1088 | 1120 | 2047 | Th |
| | Active | $T_{disp(v)}$ | 1080 | 1080 | 1080 | Th |
| | Blanking | $T_{bp(v)}+T_{fp(v)}+PW_{vs}$ | 8 | 40 | 967 | Th |
| Horizontal Section | Period | T_h | 1034 | 1060 | 2047 | Tclk |
| | Active | $T_{disp(h)}$ | 960 | 960 | 960 | Tclk |
| | Blanking | $T_{bp(h)}+T_{fp(h)}+PW_{hs}$ | 74 | 100 | 1087 | Tclk |
| Clock | Period | Tclk | 25 | 13.3 | 11.1 | ns |
| | Frequency | Freq | 40 | 75 | 94 | MHz |
| Frame rate | Frame rate | F | 50 | 60 | 75 | Hz |

Note : DE mode only



Product Specification

M215HW03 V2

AU OPTRONICS CORPORATION

6.5 Timing diagram

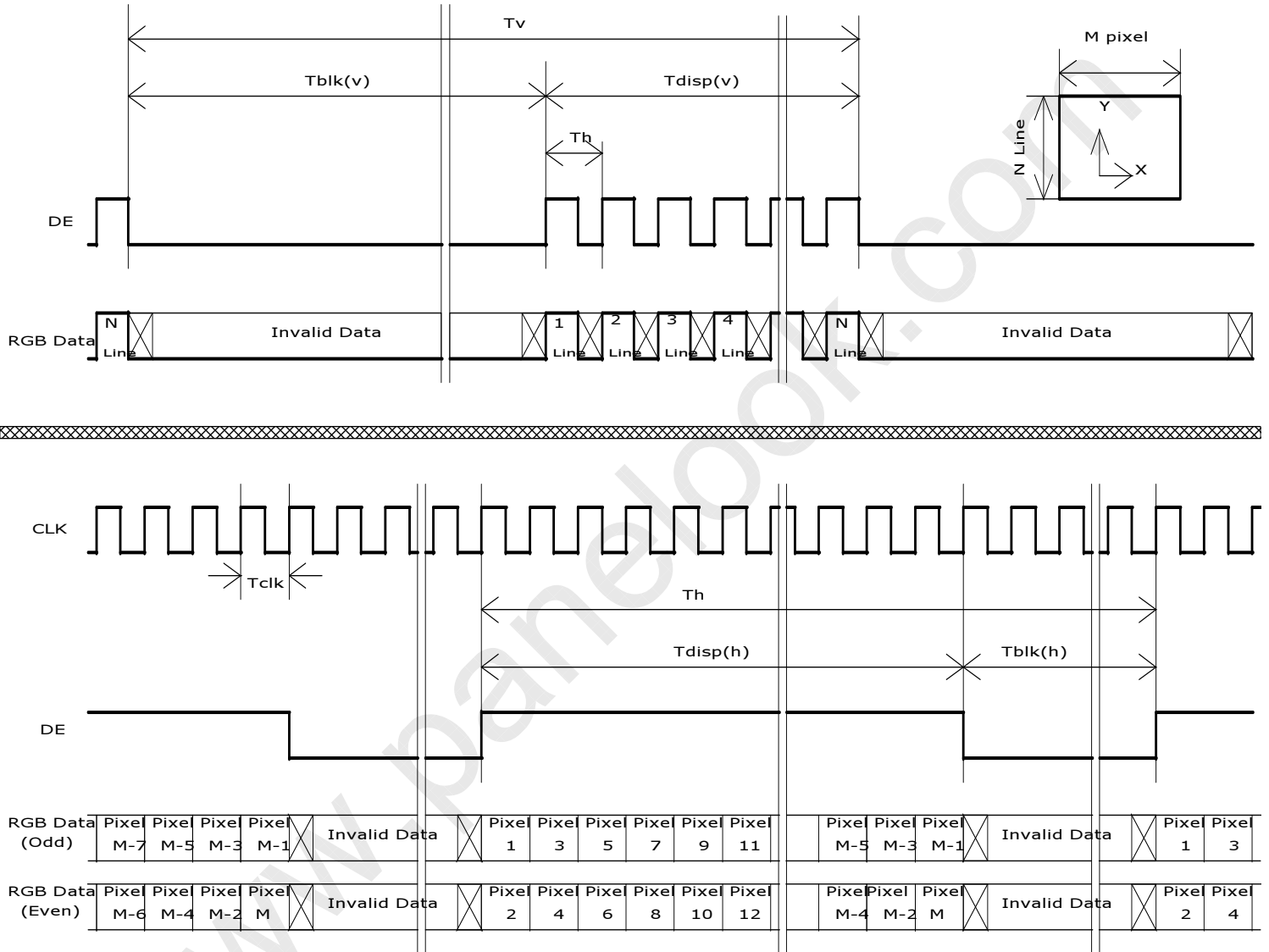



Product Specification

M215HW03 V2

AU OPTRONICS CORPORATION

6.6 Power ON/OFF Sequence

VDD power and backlight on/off sequence are as follows. Interface signals are also shown in the chart. Signals from any system shall be Hi-Z state or low level when VDD is off.

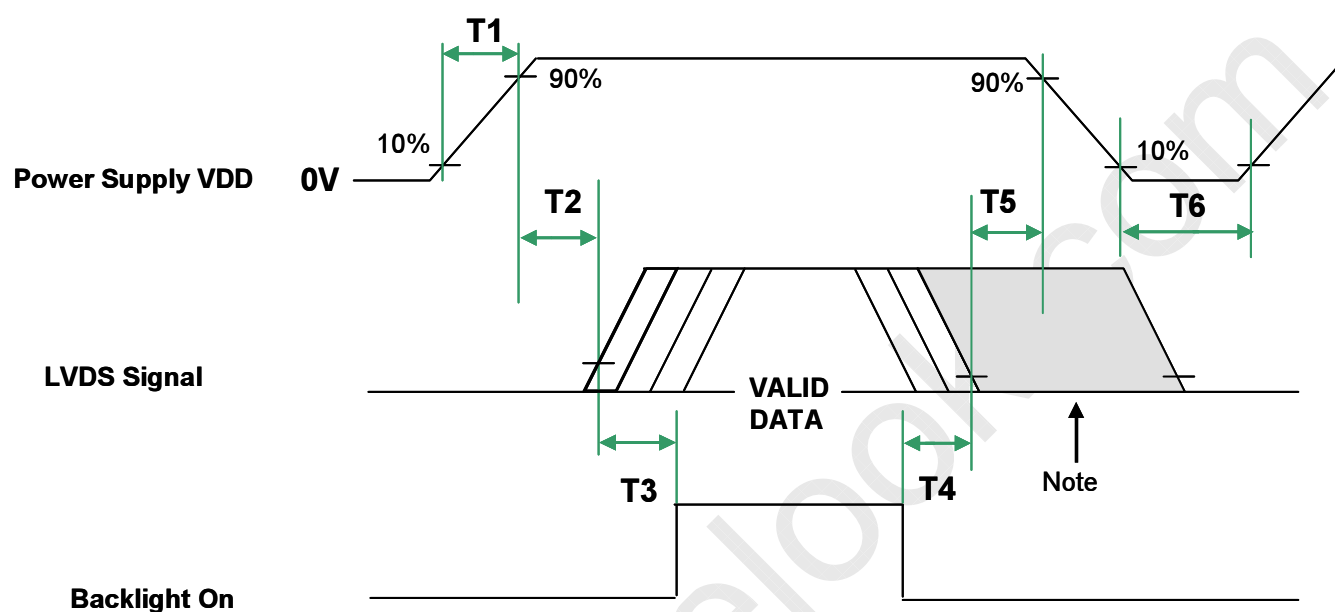

Note : Insert a white pattern after valid data and last until VDD falls to 10%

| Parameter | Value | | Unit |
|-----------|-------|------|--------|
| | Min. | Max. | |
| T1 | 0.5 | 10 | [msec] |
| T2 | 0 | 50 | [msec] |
| T3 | 500 | - | [msec] |
| T4 | 200 | - | [msec] |
| T5 | 40 | - | [msec] |
| T6 | 1000 | - | [msec] |



Product Specification

M215HW03 V2

AU OPTRONICS CORPORATION

7.0 Connector & Pin Assignment

Physical interface is described as for the connector on module. These connectors are capable of accommodating the following signals and will be following components.

7.1 TFT LCD Module

| Connector Name / Designation | Interface Connector / Interface card |
|------------------------------|--------------------------------------------------|
| Manufacturer | JAE, P-TWO, |
| Type Part Number | JAE-FI-XPB30SRLA-HF11 P-TWO-187121-30091-3(A) |
| Mating Housing Part Number | FI-X30HL (Locked Type) |

7.1.1 Pin Assignment

| Pin# | Signal Name | Pin# | Signal Name |
|------|----------------------------------------|------|----------------------------------------|
| 1 | RxOIN0- | 2 | RxOIN0+ |
| 3 | RxOIN1- | 4 | RxOIN1+ |
| 5 | RxOIN2- | 6 | RxOIN2+ |
| 7 | GND | 8 | RxOCLKIN- |
| 9 | RxOCLKIN+ | 10 | RxOIN3- |
| 11 | RxOIN3+ | 12 | RxEIN0- |
| 13 | RxEIN0+ | 14 | GND |
| 15 | RxEIN1- | 16 | RxEIN1+ |
| 17 | GND | 18 | RxEIN2- |
| 19 | RxEIN2+ | 20 | RxECLKIN- |
| 21 | RxECLKIN+ | 22 | RxEIN3- |
| 23 | RxEIN3+ | 24 | GND |
| 25 | NC (for AUO test only. Do not connect) | 26 | NC (for AUO test only. Do not connect) |
| 27 | NC (for AUO test only. Do not connect) | 28 | VDD |
| 29 | VDD | 30 | VDD |



Product Specification

M215HW03 V2

AU OPTRONICS CORPORATION

7.2 Connector on Backlight Unit.

This connector is mounted on LED light-bar.

| | |
|------------------------------|-----------------------|
| Connector Name / Designation | Light Bar Connector |
| Manufacturer | ENTERY |
| Type Part Number | 3707K-S06N-21R |
| Mating Type Part Number | ENTERY H112K-P06N-03B |

7.2.1 Signal for LED light bar connector

| Pin no. | Signal name |
|---------|--------------------------------|
| 1 | I _{LED} (current out) |
| 2 | I _{LED} (current out) |
| 3 | V _{LED} (voltage in) |
| 4 | V _{LED} (voltage in) |
| 5 | I _{LED} (current out) |
| 6 | I _{LED} (current out) |



Product Specification

M215HW03 V2

AU OPTRONICS CORPORATION

8.0 Reliability Test

Environment test conditions are listed as following table.

| Items | Required Condition | Note |
|-----------------------------------|---------------------------------------------------------------------------------------------------------------|----------|
| Temperature Humidity Bias (THB) | Ta= 50□, 80%RH, 300hours | |
| High Temperature Operation (HTO) | Ta= 50□, 50%RH, 300hours | |
| Low Temperature Operation (LTO) | Ta= 0□, 300hours | |
| High Temperature Storage (HTS) | Ta= 60□, 300hours | |
| Low Temperature Storage (LTS) | Ta= -20□, 300hours | |
| Vibration Test (Non-operation) | Acceleration: 1.5 Grms Wave: Random Frequency: 10 - 200 Hz Sweep: 30 Minutes each Axis (X, Y, Z) | |
| Shock Test (Non-operation) | Acceleration: 50 G Wave: Half-sine Active Time: 20 ms Direction: ±X, ±Y, ±Z (one time for each Axis) | |
| Drop Test | Height: 60 cm, package test | |
| Thermal Shock Test (TST) | -20□/30min, 60□/30min, 100 cycles | 1 |
| On/Off Test | On/10sec, Off/10sec, 30,000 cycles | |
| ESD (Electro Static Discharge) | Contact Discharge: ± 8KV, 150pF(330Ω) 1sec, 8 points, 25 times/ point. | 2 |
| | Air Discharge: ± 15KV, 150pF(330Ω) 1sec 8 points, 25 times/ point. | |
| Altitude Test | Operation:10,000 ft Non-Operation:30,000 ft | |

Note 1: The TFT-LCD module will not sustain damage after being subjected to 100 cycles of rapid temperature change. A cycle of rapid temperature change consists of varying the temperature from -20□ to 60□, and back again. Power is not applied during the test. After temperature cycling, the unit is placed in normal room ambient for at least 4 hours before power on.

Note 2: EN61000-4-2, ESD class B: Certain performance degradation allowed
No data lost
Self-recoverable
No hardware failures.



Product Specification

M215HW03 V2

AU OPTRONICS CORPORATION

9.0 Shipping Label

The label is on the panel as shown below:

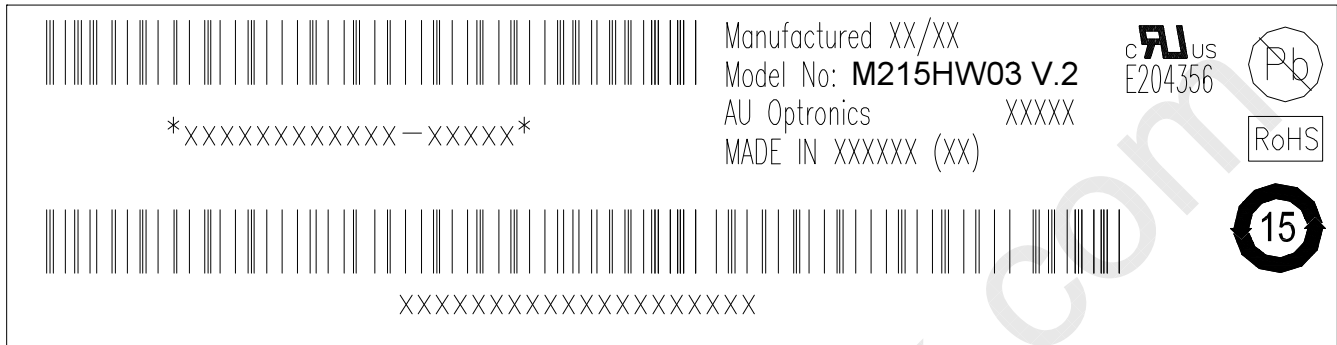

Note 1: For Pb Free products, AUO will add  for identification.

Note 2: For RoHS compatible products, AUO will add  for identification.

Note 3: For China RoHS compatible products, AUO will add  for identification.

Note 4: The Green Mark will be presented only when the green documents have been ready by AUO Internal Green Team.

10.0 Mechanical Characteristics

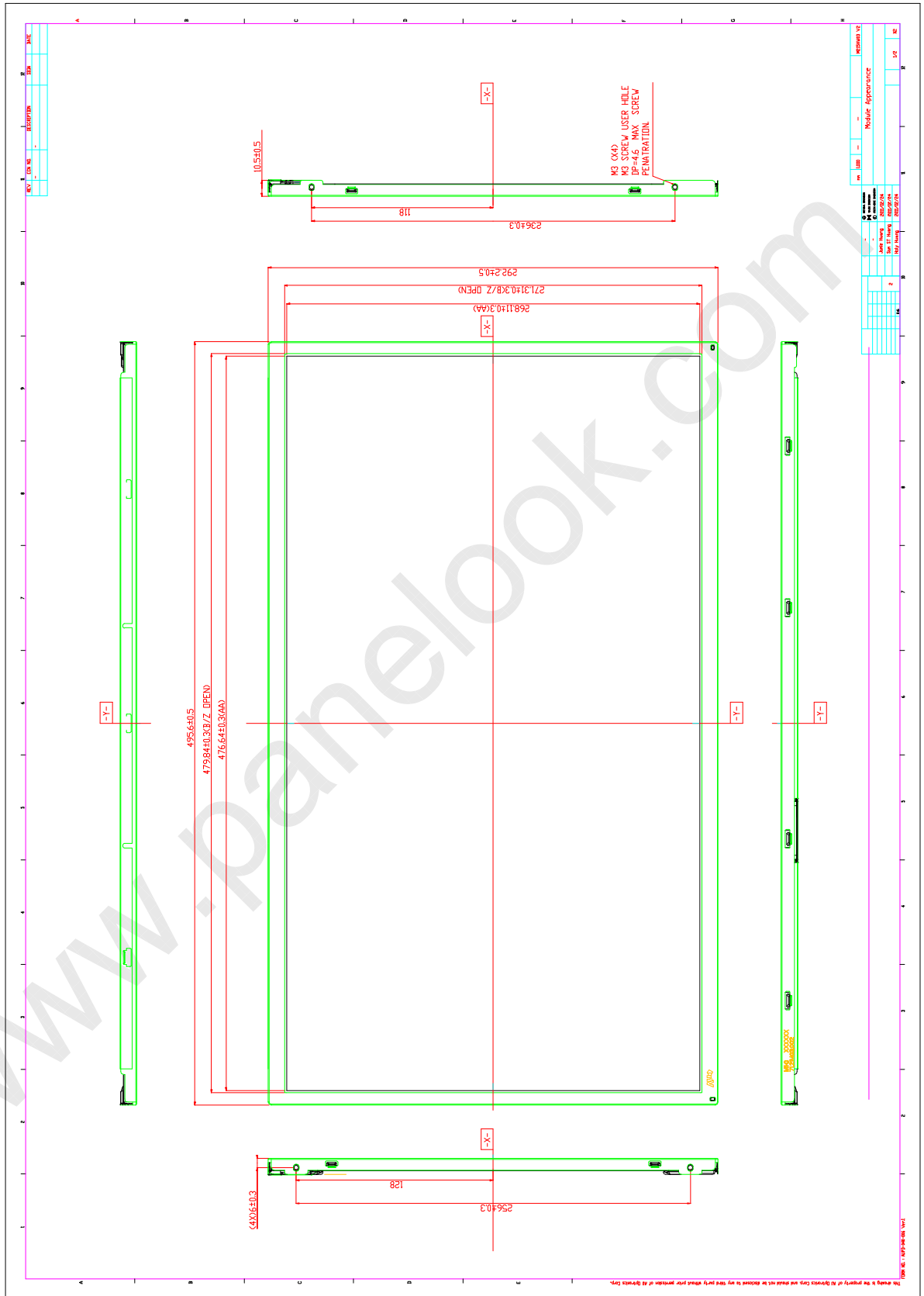

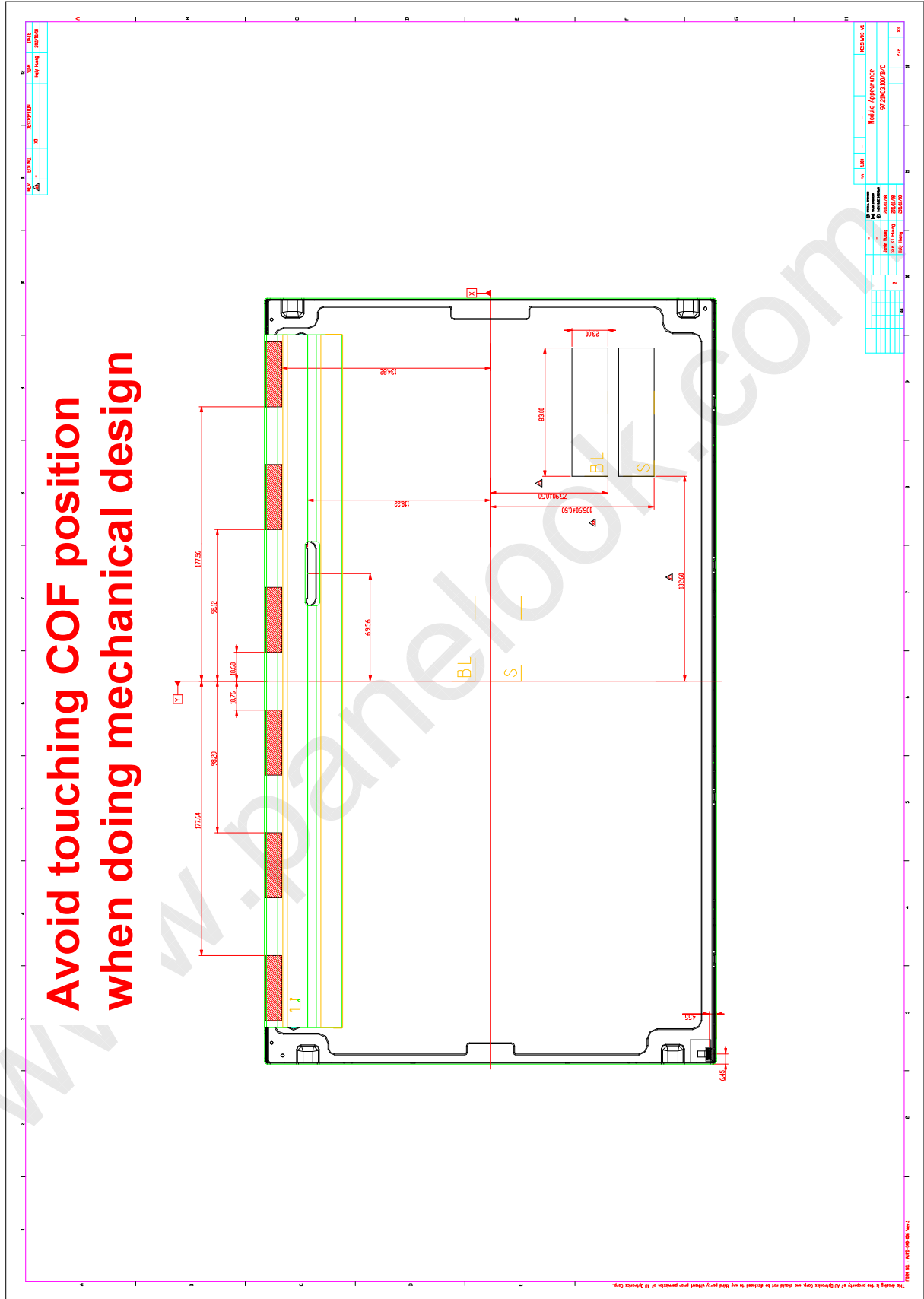

Avoid touching COF position when doing mechanical design

11. Packing Specification

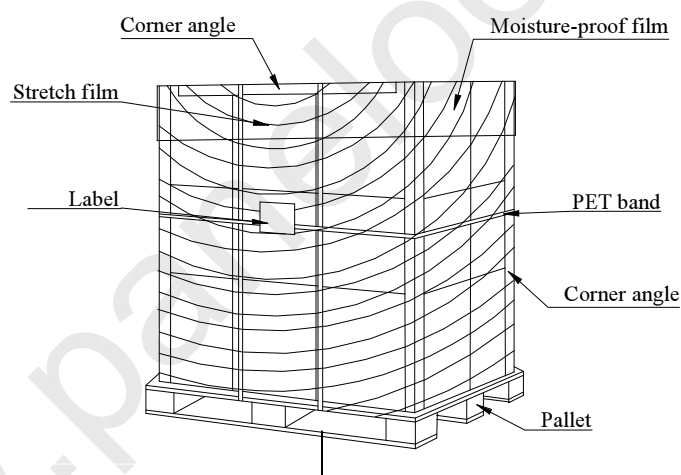
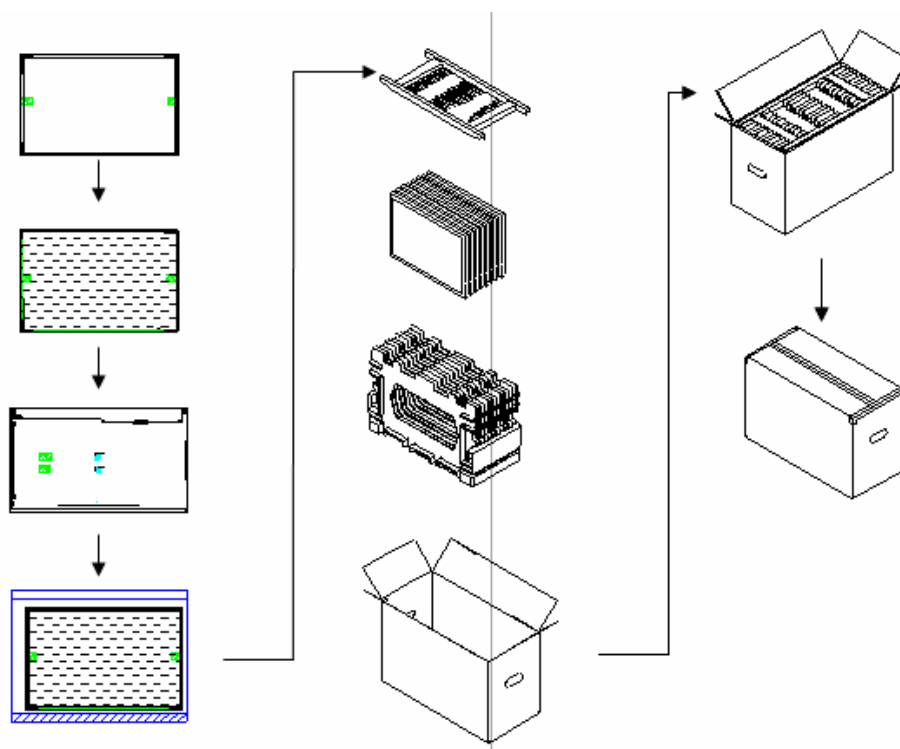

2. Pallet and shipment information

| | Item | Specification | | | Remark |
|---|----------------------|-----------------|-----------------------------------|------------|-------------------------|
| | | Q'ty | Dimension | Weight(kg) | |
| 1 | Panel | 1 | 556(H)mm x 323(V)mm x 17.1(D)mm | 1.75 | |
| 2 | Cushion | 1 | - | 1.11 | |
| 3 | Box | 1 | 568(L)mm x 277(W)mm x 382(H)mm | 1.035 | without Panel & cushion |
| 4 | Packing Box | 10 pcs/Box | 568(L)mm x 277(W)mm x 382(H)mm | 19.645 | with panel & cushion |
| 5 | Pallet | 1 | 1150(L)mm x 840(W)mm x 138(H)mm | 12 | |
| 6 | Pallet after Packing | 18 boxes/pallet | 1150(L)mm x 840(W)mm x 128.6(H)mm | 365.6 | |