



() Preliminary Specification
(V) Final Specification

Module	21.5" Color TFT-LCD
Model Name	M215XTN01.0

Customer	Date
_____	_____
Approved by	
_____	_____
<p>Note: This Specification is subject to change without notice.</p>	

Approved by	Date
<u>Howard Lee</u>	<u>Oct 22, 2012</u>
Prepared by	Date
<u>AlanCHLiu</u>	<u>Oct 22, 2012</u>
<p>AU Optronics corporation</p>	

AUO Confidential For ACMEPOINT Internal Use Only / 2013/1/17

Contents

1.0 Handling Precautions.....	4
2.0 General Description	5
2.1 Display Characteristics.....	5
2.2 Optical Characteristics	6
3.0 Functional Block Diagram	11
4.0 Absolute Maximum Ratings	12
4.1 TFT LCD Module	12
4.2 Backlight Unit.....	12
4.3 Absolute Ratings of Environment.....	12
5.0 Electrical characteristics.....	14
5.1 TFT LCD Module	14
5.1.1 Power Specification	14
5.1.2 Signal Electrical Characteristics.....	15
5.2 Backlight Unit.....	16
6.0 Signal Characteristic.....	18
6.1 Pixel Format Image	18
6.2 The input data format	18
6.3 Signal Description	19
6.4 Timing Characteristics	21
6.5 Timing diagram	22
6.6 Power ON/OFF Sequence	23
7.0 Connector & Pin Assignment	24
7.1 TFT LCD Module	24
7.1.1 Pin Assignment	24
7.2 LED Connector on Backlight Unit.....	25
7.2.1 LED Pin assignment.....	25
7.2.2 LED Connector Dimension	26
7.2.3 LED Mating housing dimension.....	26
8.0 Reliability Test.....	27
9.0 Shipping Label	28
10.0 Mechanical Characteristics	29
11. Packing Specification.....	31
11.1 Packing Flow.....	31
11.2 Pallet and shipment information.....	31

Record of Revision

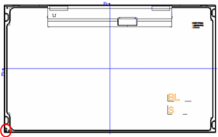
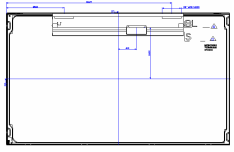
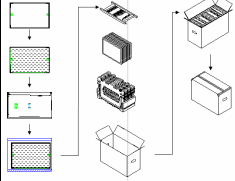
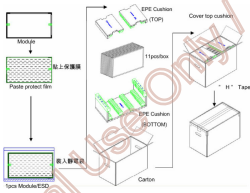
Version and Date	Page	Old description	New Description	Remark																																																																																																																																								
0.1 2012/8/22	All	First Edition for Customer	-																																																																																																																																									
	6	2.2 Optical Characteristics <table border="1"> <tr><td>Red x</td><td>0.605</td><td>0.635</td><td>0.665</td></tr> <tr><td>Red y</td><td>0.300</td><td>0.330</td><td>0.361</td></tr> <tr><td>Green x</td><td>0.287</td><td>0.317</td><td>0.347</td></tr> <tr><td>Green y</td><td>0.596</td><td>0.626</td><td>0.656</td></tr> <tr><td>Blue x</td><td>0.128</td><td>0.158</td><td>0.188</td></tr> <tr><td>Blue y</td><td>0.029</td><td>0.059</td><td>0.089</td></tr> </table>	Red x	0.605	0.635	0.665	Red y	0.300	0.330	0.361	Green x	0.287	0.317	0.347	Green y	0.596	0.626	0.656	Blue x	0.128	0.158	0.188	Blue y	0.029	0.059	0.089	<table border="1"> <tr><td>Red x</td><td>0.615</td><td>0.645</td><td>0.675</td></tr> <tr><td>Red y</td><td>0.303</td><td>0.333</td><td>0.363</td></tr> <tr><td>Green x</td><td>0.287</td><td>0.317</td><td>0.347</td></tr> <tr><td>Green y</td><td>0.584</td><td>0.614</td><td>0.644</td></tr> <tr><td>Blue x</td><td>0.128</td><td>0.158</td><td>0.188</td></tr> <tr><td>Blue y</td><td>0.032</td><td>0.062</td><td>0.092</td></tr> </table>	Red x	0.615	0.645	0.675	Red y	0.303	0.333	0.363	Green x	0.287	0.317	0.347	Green y	0.584	0.614	0.644	Blue x	0.128	0.158	0.188	Blue y	0.032	0.062	0.092	Revised																																																																																								
Red x	0.605	0.635	0.665																																																																																																																																									
Red y	0.300	0.330	0.361																																																																																																																																									
Green x	0.287	0.317	0.347																																																																																																																																									
Green y	0.596	0.626	0.656																																																																																																																																									
Blue x	0.128	0.158	0.188																																																																																																																																									
Blue y	0.029	0.059	0.089																																																																																																																																									
Red x	0.615	0.645	0.675																																																																																																																																									
Red y	0.303	0.333	0.363																																																																																																																																									
Green x	0.287	0.317	0.347																																																																																																																																									
Green y	0.584	0.614	0.644																																																																																																																																									
Blue x	0.128	0.158	0.188																																																																																																																																									
Blue y	0.032	0.062	0.092																																																																																																																																									
	19	6.3 Signal Description 		Revised																																																																																																																																								
	16	5.2 Backlight Unit <table border="1"> <tr><td>V_{LA}</td><td>Light Bar Operation Voltage (for reference)</td><td>-</td><td>32</td><td>36</td><td>[Vdc]</td></tr> </table>	V _{LA}	Light Bar Operation Voltage (for reference)	-	32	36	[Vdc]	<table border="1"> <tr><td>V_{LA}</td><td>Light Bar Operation Voltage (for reference)</td><td>30</td><td>32</td><td>36</td><td>[Vdc] Note 2</td></tr> </table>	V _{LA}	Light Bar Operation Voltage (for reference)	30	32	36	[Vdc] Note 2	Revised																																																																																																																												
V _{LA}	Light Bar Operation Voltage (for reference)	-	32	36	[Vdc]																																																																																																																																							
V _{LA}	Light Bar Operation Voltage (for reference)	30	32	36	[Vdc] Note 2																																																																																																																																							
	26	8.0 Reliability Test <table border="1"> <tr><td>Altitude Test</td><td>Operation 10,000 ft Non-Operation 30,000 ft</td></tr> </table>	Altitude Test	Operation 10,000 ft Non-Operation 30,000 ft	<table border="1"> <tr><td>Altitude Test</td><td>Operation 18,000 ft Non-Operation 40,000 ft</td></tr> </table>	Altitude Test	Operation 18,000 ft Non-Operation 40,000 ft	Revised																																																																																																																																				
Altitude Test	Operation 10,000 ft Non-Operation 30,000 ft																																																																																																																																											
Altitude Test	Operation 18,000 ft Non-Operation 40,000 ft																																																																																																																																											
	30	11. Packing Specification  <table border="1"> <thead> <tr><th rowspan="2">Item</th><th colspan="3">Specification</th></tr> <tr><th>Qty</th><th>Dimension</th><th>Weight(g)</th></tr> </thead> <tbody> <tr><td>Panel</td><td>1</td><td>556(±0.05)mm x 323(±0.05)mm x 1.7 (±0.05)mm</td><td>1.75</td></tr> <tr><td>Cushion</td><td>1</td><td>-</td><td>1.11</td></tr> <tr><td>Box</td><td>1</td><td>565(±0.05)mm x 271(±0.05)mm x 82(±0.05)mm</td><td>1.68</td></tr> <tr><td>Packing Box</td><td>10 pcs/Box</td><td>565(±0.05)mm x 271(±0.05)mm x 82(±0.05)mm</td><td>16.8</td></tr> <tr><td>Panel</td><td>1</td><td>1130(±0.05)mm x 846(±0.05)mm x 13.6(±0.05)mm</td><td>32</td></tr> <tr><td>Panel after Packing</td><td>10 items/panel</td><td>1130(±0.05)mm x 846(±0.05)mm x 13.6(±0.05)mm</td><td>365.6</td></tr> </tbody> </table>	Item	Specification			Qty	Dimension	Weight(g)	Panel	1	556(±0.05)mm x 323(±0.05)mm x 1.7 (±0.05)mm	1.75	Cushion	1	-	1.11	Box	1	565(±0.05)mm x 271(±0.05)mm x 82(±0.05)mm	1.68	Packing Box	10 pcs/Box	565(±0.05)mm x 271(±0.05)mm x 82(±0.05)mm	16.8	Panel	1	1130(±0.05)mm x 846(±0.05)mm x 13.6(±0.05)mm	32	Panel after Packing	10 items/panel	1130(±0.05)mm x 846(±0.05)mm x 13.6(±0.05)mm	365.6	 <table border="1"> <thead> <tr><th rowspan="2">Item</th><th colspan="3">Specification</th></tr> <tr><th>Qty</th><th>Dimension</th><th>Weight(g)</th></tr> </thead> <tbody> <tr><td>Panel</td><td>1</td><td>485(±0.05)mm x 293(±0.05)mm x 3.0(±0.05)mm</td><td>1.80</td></tr> <tr><td>Cushion</td><td>1</td><td>-</td><td>0.40</td></tr> <tr><td>Box</td><td>1</td><td>556(±0.05)mm x 293(±0.05)mm x 37.5(±0.05)mm</td><td>0.85</td></tr> <tr><td>Packing Box</td><td>11 pcs/Box</td><td>556(±0.05)mm x 293(±0.05)mm x 37.5(±0.05)mm</td><td>11.15</td></tr> <tr><td>Panel</td><td>1</td><td>1130(±0.05)mm x 1306(±0.05)mm x 13.6(±0.05)mm</td><td>13.00</td></tr> <tr><td>Panel after Packing</td><td>10 items/panel</td><td>1130(±0.05)mm x 1306(±0.05)mm x 13.6(±0.05)mm</td><td>361.70</td></tr> </tbody> </table>	Item	Specification			Qty	Dimension	Weight(g)	Panel	1	485(±0.05)mm x 293(±0.05)mm x 3.0(±0.05)mm	1.80	Cushion	1	-	0.40	Box	1	556(±0.05)mm x 293(±0.05)mm x 37.5(±0.05)mm	0.85	Packing Box	11 pcs/Box	556(±0.05)mm x 293(±0.05)mm x 37.5(±0.05)mm	11.15	Panel	1	1130(±0.05)mm x 1306(±0.05)mm x 13.6(±0.05)mm	13.00	Panel after Packing	10 items/panel	1130(±0.05)mm x 1306(±0.05)mm x 13.6(±0.05)mm	361.70	Revised																																																																										
Item	Specification																																																																																																																																											
	Qty	Dimension	Weight(g)																																																																																																																																									
Panel	1	556(±0.05)mm x 323(±0.05)mm x 1.7 (±0.05)mm	1.75																																																																																																																																									
Cushion	1	-	1.11																																																																																																																																									
Box	1	565(±0.05)mm x 271(±0.05)mm x 82(±0.05)mm	1.68																																																																																																																																									
Packing Box	10 pcs/Box	565(±0.05)mm x 271(±0.05)mm x 82(±0.05)mm	16.8																																																																																																																																									
Panel	1	1130(±0.05)mm x 846(±0.05)mm x 13.6(±0.05)mm	32																																																																																																																																									
Panel after Packing	10 items/panel	1130(±0.05)mm x 846(±0.05)mm x 13.6(±0.05)mm	365.6																																																																																																																																									
Item	Specification																																																																																																																																											
	Qty	Dimension	Weight(g)																																																																																																																																									
Panel	1	485(±0.05)mm x 293(±0.05)mm x 3.0(±0.05)mm	1.80																																																																																																																																									
Cushion	1	-	0.40																																																																																																																																									
Box	1	556(±0.05)mm x 293(±0.05)mm x 37.5(±0.05)mm	0.85																																																																																																																																									
Packing Box	11 pcs/Box	556(±0.05)mm x 293(±0.05)mm x 37.5(±0.05)mm	11.15																																																																																																																																									
Panel	1	1130(±0.05)mm x 1306(±0.05)mm x 13.6(±0.05)mm	13.00																																																																																																																																									
Panel after Packing	10 items/panel	1130(±0.05)mm x 1306(±0.05)mm x 13.6(±0.05)mm	361.70																																																																																																																																									
	20	6.4 Timing Characteristics <table border="1"> <thead> <tr><th>Signal</th><th>Item</th><th>Symbol</th><th>Min</th><th>Typ</th><th>Max</th><th>Unit</th></tr> </thead> <tbody> <tr><td rowspan="3">Vertical Section</td><td>Period</td><td>Tv</td><td>776</td><td>808</td><td>1023</td><td>Th</td></tr> <tr><td>Active</td><td>Tdssp(v)</td><td>768</td><td>768</td><td>768</td><td>Th</td></tr> <tr><td>Blanking</td><td>Tbp(v)+Tfp(v)+PWvs</td><td>8</td><td>40</td><td>255</td><td>Th</td></tr> <tr><td rowspan="3">Horizontal Section</td><td>Period</td><td>Th</td><td>1416</td><td>1606</td><td>2047</td><td>Tck</td></tr> <tr><td>Active</td><td>Tdssp(h)</td><td>1366</td><td>1366</td><td>1366</td><td>Tck</td></tr> <tr><td>Blanking</td><td>Tbp(h)+Tfp(h)+PWvs</td><td>50</td><td>240</td><td>681</td><td>Tck</td></tr> <tr><td rowspan="2">Clock</td><td>Period</td><td>Tclk</td><td>-</td><td>12.8</td><td>-</td><td>ns</td></tr> <tr><td>Frequency</td><td>Freq</td><td>55</td><td>78</td><td>90</td><td>MHz</td></tr> <tr><td rowspan="2">Frame rate</td><td>Frame rate</td><td>F</td><td>50</td><td>60</td><td>75</td><td>Hz</td></tr> </tbody> </table>	Signal	Item	Symbol	Min	Typ	Max	Unit	Vertical Section	Period	Tv	776	808	1023	Th	Active	Tdssp(v)	768	768	768	Th	Blanking	Tbp(v)+Tfp(v)+PWvs	8	40	255	Th	Horizontal Section	Period	Th	1416	1606	2047	Tck	Active	Tdssp(h)	1366	1366	1366	Tck	Blanking	Tbp(h)+Tfp(h)+PWvs	50	240	681	Tck	Clock	Period	Tclk	-	12.8	-	ns	Frequency	Freq	55	78	90	MHz	Frame rate	Frame rate	F	50	60	75	Hz	<table border="1"> <thead> <tr><th>Signal</th><th>Item</th><th>Symbol</th><th>Min</th><th>Typ</th><th>Max</th><th>Unit</th></tr> </thead> <tbody> <tr><td rowspan="3">Vertical Section</td><td>Period</td><td>Tv</td><td>793</td><td>808</td><td>1283</td><td>Th</td></tr> <tr><td>Active</td><td>Tdssp(v)</td><td>768</td><td>768</td><td>768</td><td>Th</td></tr> <tr><td>Blanking</td><td>Tbp(v)+Tfp(v)+PWvs</td><td>25</td><td>40</td><td>525</td><td>Th</td></tr> <tr><td rowspan="3">Horizontal Section</td><td>Period</td><td>Th</td><td>1454</td><td>1606</td><td>2047</td><td>Tck</td></tr> <tr><td>Active</td><td>Tdssp(h)</td><td>1366</td><td>1366</td><td>1366</td><td>Tck</td></tr> <tr><td>Blanking</td><td>Tbp(h)+Tfp(h)+PWvs</td><td>88</td><td>240</td><td>681</td><td>Tck</td></tr> <tr><td rowspan="2">Clock</td><td>Period</td><td>Tclk</td><td>10.6</td><td>12.8</td><td>17.4</td><td>ns</td></tr> <tr><td>Frequency</td><td>Freq</td><td>58</td><td>78</td><td>94</td><td>MHz</td></tr> <tr><td rowspan="2">Frame rate</td><td>Frame rate</td><td>F</td><td>50</td><td>60</td><td>75</td><td>Hz</td></tr> <tr><td>Refresh rate</td><td>HRfreq</td><td>72</td><td>96</td><td>153</td><td>Hz</td></tr> </tbody> </table>	Signal	Item	Symbol	Min	Typ	Max	Unit	Vertical Section	Period	Tv	793	808	1283	Th	Active	Tdssp(v)	768	768	768	Th	Blanking	Tbp(v)+Tfp(v)+PWvs	25	40	525	Th	Horizontal Section	Period	Th	1454	1606	2047	Tck	Active	Tdssp(h)	1366	1366	1366	Tck	Blanking	Tbp(h)+Tfp(h)+PWvs	88	240	681	Tck	Clock	Period	Tclk	10.6	12.8	17.4	ns	Frequency	Freq	58	78	94	MHz	Frame rate	Frame rate	F	50	60	75	Hz	Refresh rate	HRfreq	72	96	153	Hz	Revised
Signal	Item	Symbol	Min	Typ	Max	Unit																																																																																																																																						
Vertical Section	Period	Tv	776	808	1023	Th																																																																																																																																						
	Active	Tdssp(v)	768	768	768	Th																																																																																																																																						
	Blanking	Tbp(v)+Tfp(v)+PWvs	8	40	255	Th																																																																																																																																						
Horizontal Section	Period	Th	1416	1606	2047	Tck																																																																																																																																						
	Active	Tdssp(h)	1366	1366	1366	Tck																																																																																																																																						
	Blanking	Tbp(h)+Tfp(h)+PWvs	50	240	681	Tck																																																																																																																																						
Clock	Period	Tclk	-	12.8	-	ns																																																																																																																																						
	Frequency	Freq	55	78	90	MHz																																																																																																																																						
Frame rate	Frame rate	F	50	60	75	Hz																																																																																																																																						
	Signal	Item	Symbol	Min	Typ	Max	Unit																																																																																																																																					
Vertical Section	Period	Tv	793	808	1283	Th																																																																																																																																						
	Active	Tdssp(v)	768	768	768	Th																																																																																																																																						
	Blanking	Tbp(v)+Tfp(v)+PWvs	25	40	525	Th																																																																																																																																						
Horizontal Section	Period	Th	1454	1606	2047	Tck																																																																																																																																						
	Active	Tdssp(h)	1366	1366	1366	Tck																																																																																																																																						
	Blanking	Tbp(h)+Tfp(h)+PWvs	88	240	681	Tck																																																																																																																																						
Clock	Period	Tclk	10.6	12.8	17.4	ns																																																																																																																																						
	Frequency	Freq	58	78	94	MHz																																																																																																																																						
Frame rate	Frame rate	F	50	60	75	Hz																																																																																																																																						
	Refresh rate	HRfreq	72	96	153	Hz																																																																																																																																						
1.0 2012/10/22	All	Final Version																																																																																																																																										

1.0 Handling Precautions

- 1) Since front polarizer is easily damaged, pay attention not to scratch it.
- 2) Be sure to turn off power supply when inserting or disconnecting from input connector.
- 3) Wipe off water drop immediately. Long contact with water may cause discoloration or spots.
- 4) When the panel surface is soiled, wipe it with absorbent cotton or other soft cloth.
- 5) Since the panel is made of glass, it may break or crack if dropped or bumped on hard surface.
- 6) Since CMOS LSI is used in this module, take care of static electricity and insure human earth when handling.
- 7) Do not open or modify the Module Assembly.
- 8) Do not press the reflector sheet at the back of the module to any directions.
- 9) In case if a Module has to be put back into the packing container slot after once it was taken out from the container, do not press the center of the LED lightbar edge. Instead, press at the far ends of the LED light bar edge softly. Otherwise the TFT Module may be damaged.
- 10) At the insertion or removal of the Signal Interface Connector, be sure not to rotate nor tilt the Interface Connector of the TFT Module.
- 11) After installation of the TFT Module into an enclosure, do not twist nor bend the TFT Module even momentary. At designing the enclosure, it should be taken into consideration that no bending/twisting forces are applied to the TFT Module from outside. Otherwise the TFT Module may be damaged.
- 12) Small amount of materials having no flammability grade is used in the LCD module. The LCD module should be supplied by power complied with requirements of Limited Power Source (IEC60950 or UL1950), or be applied exemption.
- 13) Pls avoid touching COF position while you are doing mechanical design.
- 14) When storing modules as spares for a long time, the following precaution is necessary:
Store them in a dark place. Do not expose the module to sunlight or fluorescent light.
Keep the temperature between 5°C and 35°C at normal humidity.

2.0 General Description

This specification applies to the 21.5 inch-wide Color a-Si TFT-LCD Module M215XTN01.0. The display supports the WXGA - 1366(H) x 768(V) screen format and 16.7M colors (RGB 6-bits + Hi-FRC data). All input signals are 1-channel LVDS interface and this module doesn't contain an driver board for backlight.

2.1 Display Characteristics

The following items are characteristics summary on the table under 25□ condition:

ITEMS	Unit	SPECIFICATIONS
Screen Diagonal	[mm]	546.86(21.53")
Active Area	[mm]	476.64 (H) x 267.96 (V)
Pixels H x V		1366(x3) x 768
Pixel Pitch	[um]	348.9 (per one triad) x 348.9 um
Pixel Arrangement		R.G.B. Vertical Stripe
Display Mode		TN Mode, Normally White
White Luminance (Center)	[cd/m ²]	200cd/m ² (Typ.)
Contrast Ratio		600 (Typ.)
Optical Response Time	[msec]	5ms (Typ., on/off)
Nominal Input Voltage VDD	[Volt]	+5.0 V
Power Consumption (VDD line + LED line)	[Watt]	11.97 watt VDD line : PDD (typ), All black pattern at 60Hz = 3.65W LED line : PBLU (typ) = 8.32 W
Weight	[Grams]	1750
Physical Size	[mm]	495.6(W) × 292.2(H) × 10.3(D) Typ.
Electrical Interface		One channel LVDS
Support Color		16.7M colors (RGB 6-bit + Hi_FRC)
Surface Treatment		Anti-Glare, 3H
Temperature Range		
Operating	[°C]	0 to +50
Storage (Shipping)	[°C]	-20 to +60
RoHS Compliance		RoHS Compliance
TCO Compliance		N/A

2.2 Optical Characteristics

The optical characteristics are measured under stable conditions at 25□:

Item	Unit	Conditions	Min.	Typ.	Max.	Note
Viewing Angle	[degree]	Horizontal (Right) CR = 10 (Left)	40 40	45 45	- -	2
		Vertical (Up) CR = 10 (Down)	15 40	20 45	- -	
Contrast ratio		Normal Direction	360	600	-	3
Color Gamut	%			72		
Response Time	[msec]	Raising Time (T _{rR})	-	3.8	5.5	4
		Falling Time (T _{rF})	-	1.2	2.5	
		Raising + Falling	-	5	8	
Color / Chromaticity Coordinates (CIE)		Red x	0.615	0.645	0.675	5
		Red y	0.303	0.333	0.363	
		Green x	0.287	0.317	0.347	
		Green y	0.584	0.614	0.644	
		Blue x	0.120	0.150	0.180	
		Blue y	0.032	0.062	0.092	
Color Coordinates (CIE) White		White x	0.283	0.313	0.343	
		White y	0.299	0.329	0.359	
Central Luminance	[cd/m ²]		160	200	-	6
Luminance Uniformity	[%]		75	80	-	7
Crosstalk (in 60Hz)	[%]				1.5	8
Flicker	dB				-20	9

Note 1: Measurement method

The LCD module should be stabilized at given temperature for 30 minutes to avoid abrupt temperature change during measuring (at surface 35°C). In order to stabilize the luminance, the measurement should be executed after lighting Backlight for 30 minutes in a stable, windless and dark room.

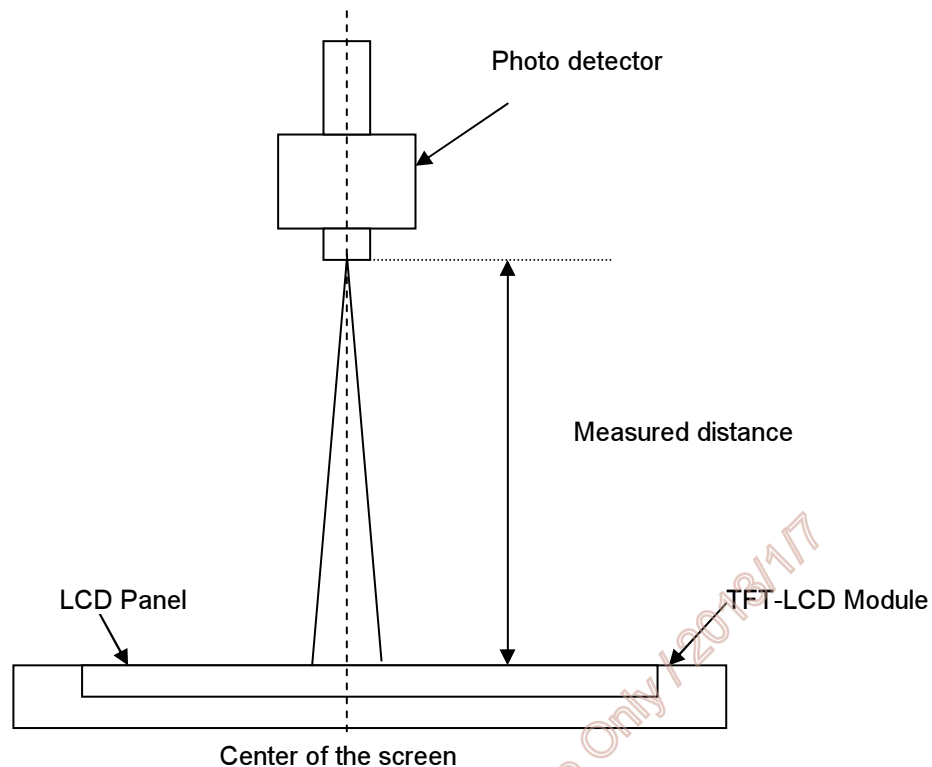

Note 2: Definition of viewing angle measured by ELDIM (EZContrast 88)

Viewing angle is the measurement of contrast ratio ≥ 10 , at the screen center, over a 180° horizontal and 180° vertical range (off-normal viewing angles). The 180° viewing angle range is broken down as follows; 90° (θ) horizontal left and right and 90° (ϕ) vertical, high (up) and low (down). The measurement direction is typically perpendicular to the display surface with the screen rotated about its center to develop the desired measurement viewing angle.

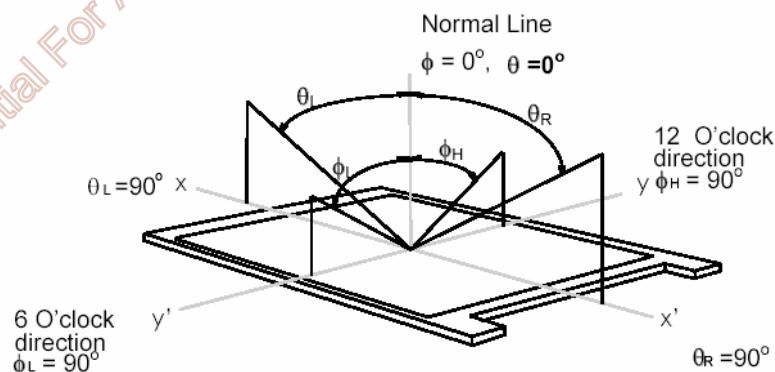

Note 3: Contrast ratio is measured by TOPCON SR-3

Note 4: Definition of Response time measured by Westar TRD-100A

The output signals of photo detector are measured when the input signals are changed from “Full Black” to “Full White” (rising time, T_{rR}), and from “Full White” to “Full Black” (falling time, T_{rF}), respectively. The response time is interval between the 10% and 90% (1 frame at 60 Hz) of amplitudes.

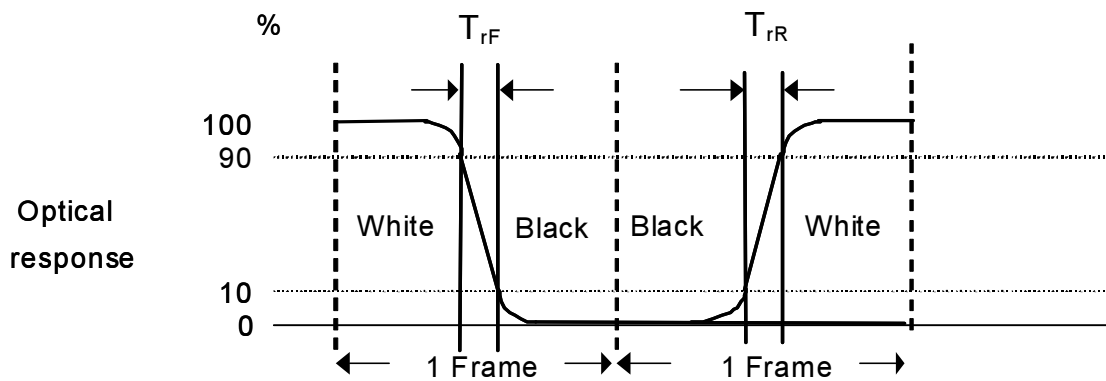

$T_{rR} + T_{rF} = 5 \text{ msec (typ.)}$.

Algorithm: $|\text{Gray Level A} - \text{Gray Level B}| \div 16$, then the average gray to gray response time is 2 ms,

($F = 60 \text{ Hz}$).

Note 5: Color chromaticity and coordinates (CIE) is measured by TOPCON SR-3

Note 6: Central luminance is measured by TOPCON SR-3

Note 7: Luminance uniformity of these 9 points is defined as below and measured by TOPCON SR-3

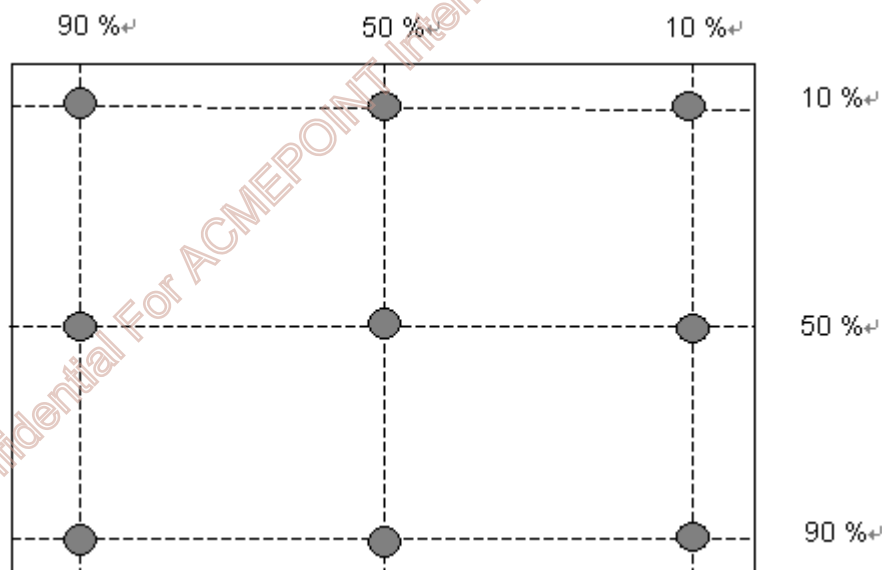

$$\text{Uniformity} = \frac{\text{Minimum Luminance in 9 points (1-9)}}{\text{Maximum Luminance in 9 Points (1-9)}}$$

Note 8: Crosstalk is defined as below and measured by TOPCON SR-3

$$CT = |Y_B - Y_A| / Y_A \times 100 (\%)$$

Where

Y_A = Luminance of measured location without gray level 0 pattern (cd/m²)

Y_B = Luminance of measured location with gray level 0 pattern (cd/m²)

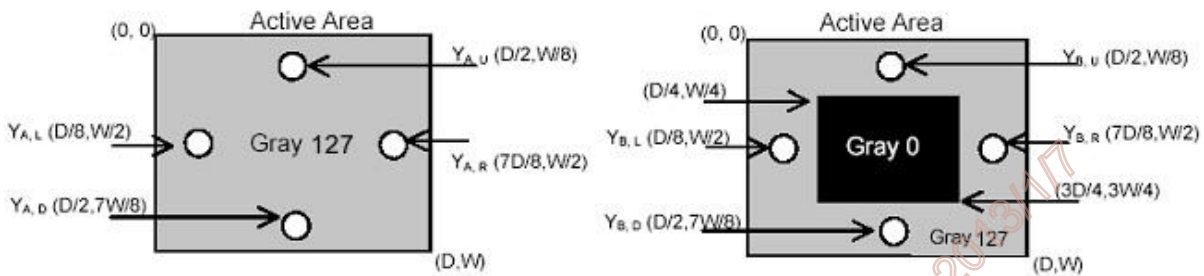

Note 9: Test Pattern: Subchecker Pattern measured by TOPCON SR-3

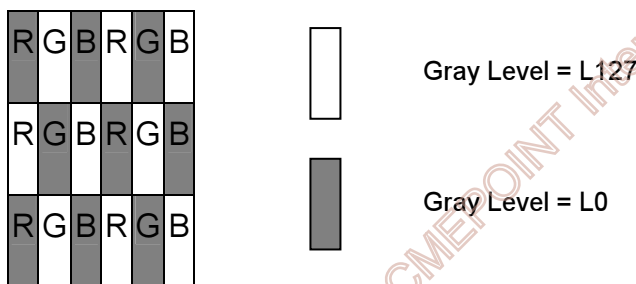

Method: Record dBV & DC value with TRD-100

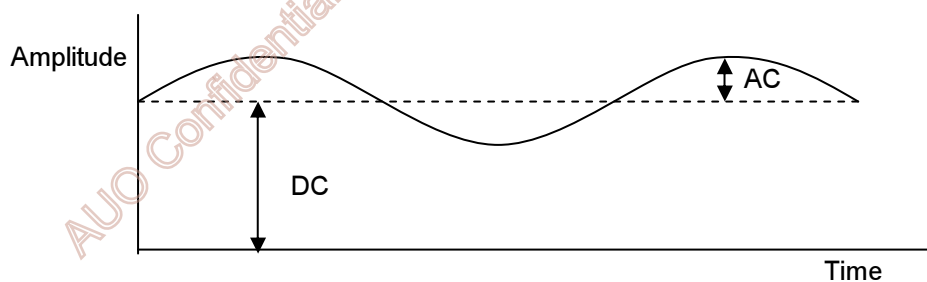



Product Specification

M215XTN01.0

AU OPTRONICS CORPORATION

$$\text{Flicker (dB)} = 20 \log \frac{\text{AC Level(at 30 Hz)}}{\text{DC Level}}$$

AUO Confidential For ACMEPPOINT Internal Use Only / 2013/1/17

3.0 Functional Block Diagram

The following diagram shows the functional block of the 21.5 inch Color TFT-LCD Module:

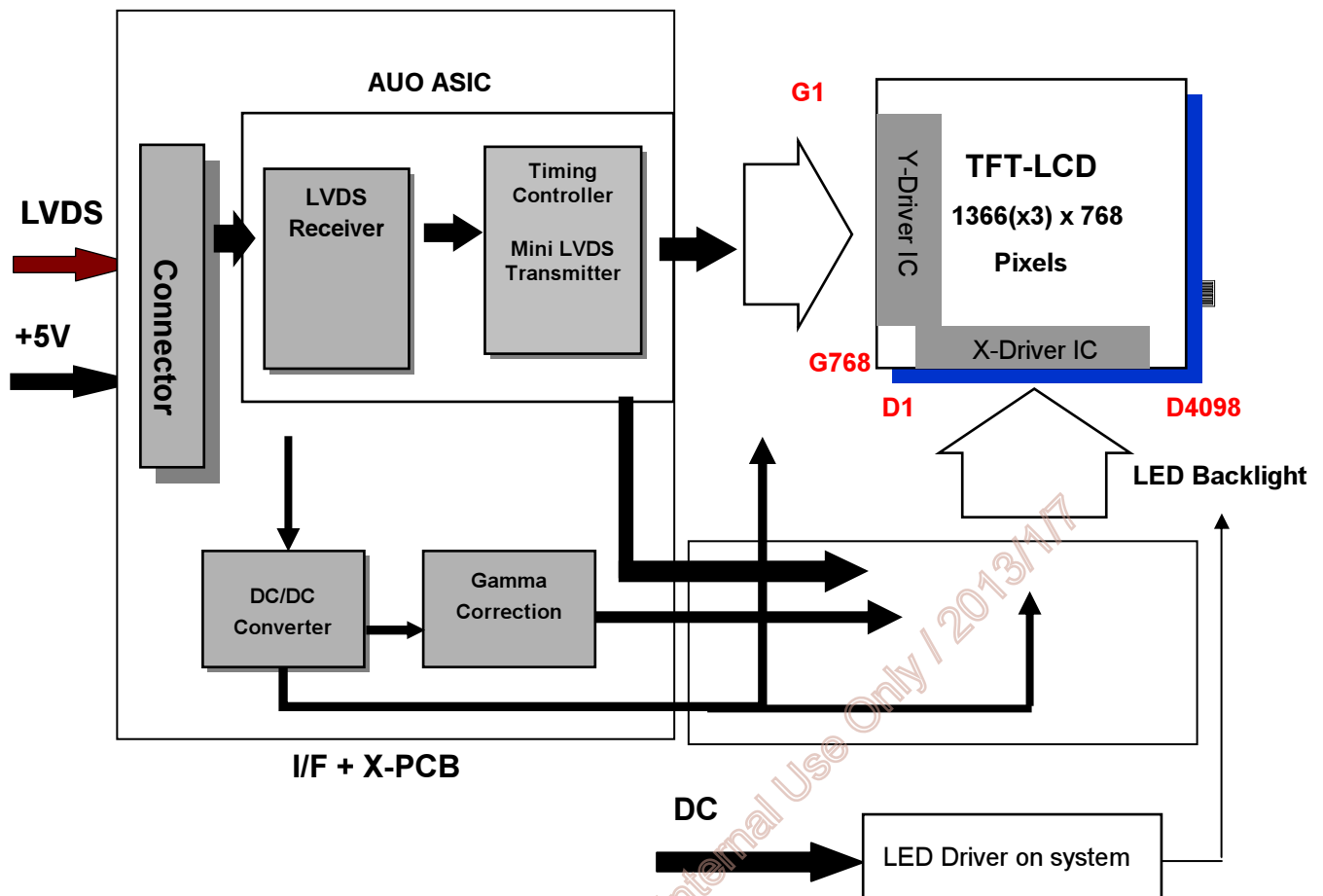

I/F PCB Interface:

MSCKT2407P30HB(STM)/AL230F-A0G1D-P(P-TWO)

Mating Type:

FI-X30HL (Locked Type)

4.0 Absolute Maximum Ratings

Absolute maximum ratings of the module are as following:

4.1 TFT LCD Module

Item	Symbol	Min	Max	Unit	Conditions
Logic/LCD Drive Voltage	VDD	-0.3	6.0	[Volt]	Note 1,2

4.2 Backlight Unit

Item	Symbol	Min	Max	Unit	Conditions
LED Forward Current	IRLED1	0	90	[mA]	Note 1,2,5 100% duty
	IRLED2				
	IRLED3				
	IRLED4				
LED Pulse Forward Current	IPLD1	-	150	[mA]	Note 1,2,5 10% duty @100Hz
	IPLD2				
	IPLD3				
	IPLD4				
LED forward Voltage variation (per string variation)	ΔV_f	-	2.0	[Volt]	Note 1,2

4.3 Absolute Ratings of Environment

Item	Symbol	Min.	Max.	Unit	Conditions
Operating Temperature	TOP	0	+50	[°C]	Note 3
Glass surface temperature (operation)	TGS	0	+65	[°C]	Note 3, Note 4
Operation Humidity	HOP	5	90	[%RH]	Note 3
Storage Temperature	TST	-20	+60	[°C]	
Storage Humidity	HST	5	90	[%RH]	

Note 1: With in Ta (25°C)

Note 2: Permanent damage to the device may occur if exceeding maximum values

Note 3: Temperature and relative humidity range are shown as the below figure.

1. 90% RH Max (Ta ≤ 39°C)
2. Max wet-bulb temperature at 39°C or less. (Ta ≤ 39°C)
3. No condensation

Note 4: Function Judged only

Note 5: IRLED1,2,3,4 and IPLD1,2,3,4 define as per strings LED current.

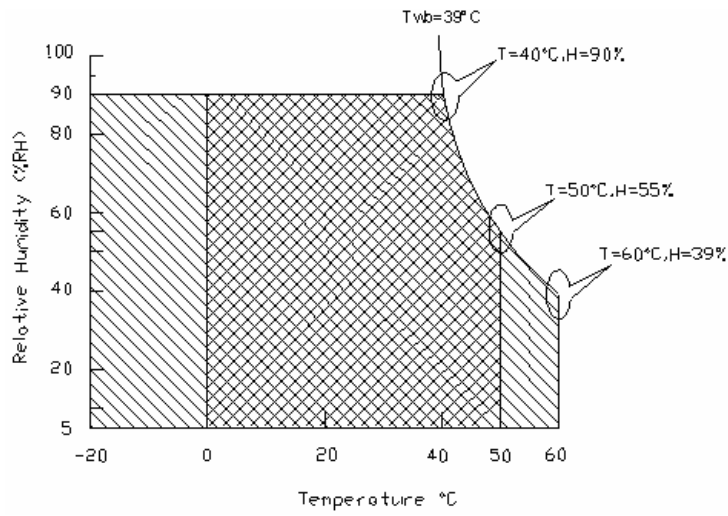

Operating Range



Storage Range

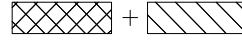

AUO Confidential For ACMEPPOINT Internal Use Only / 2013/1/17

5.0 Electrical characteristics

5.1 TFT LCD Module

5.1.1 Power Specification

Input power specifications are as following:

Symbol	Parameter	Min	Typ	Max	Unit	Conditions
VDD	Logic/LCD Drive Voltage	4.5	5.0	5.5	[Volt]	+/-10%
IDD	Input Current	-	0.73	0.88	[A]	VDD= 5.0V, All Black Pattern At 60Hz
		-	0.88	1.06	[A]	VDD= 5.0V, All Black Pattern At 75Hz
PDD	VDD Power	-	3.65	4.4	[Watt]	VDD= 5.0V, All Black Pattern At 60Hz
		-	4.4	5.3	[Watt]	VDD= 5.0V, All Black Pattern At 75Hz
IRush	Inrush Current	-	-	2	[A]	Note 1
VDDrp	Allowable Logic/LCD Drive Ripple Voltage	-	-	490	[mV] p-p	VDD= 5.0V, All Black Pattern At 75Hz

Note 1: Measurement conditions:

The duration of rising time of power input is 470us.

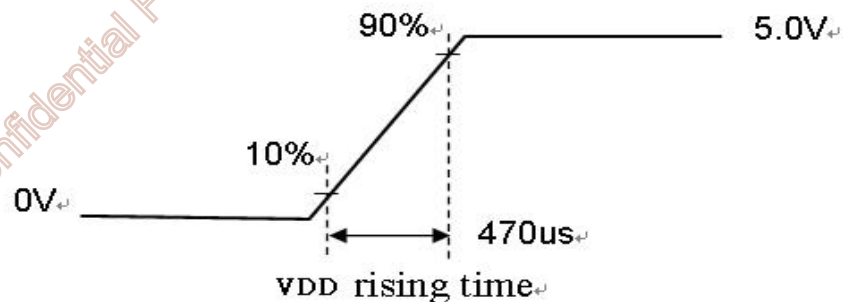
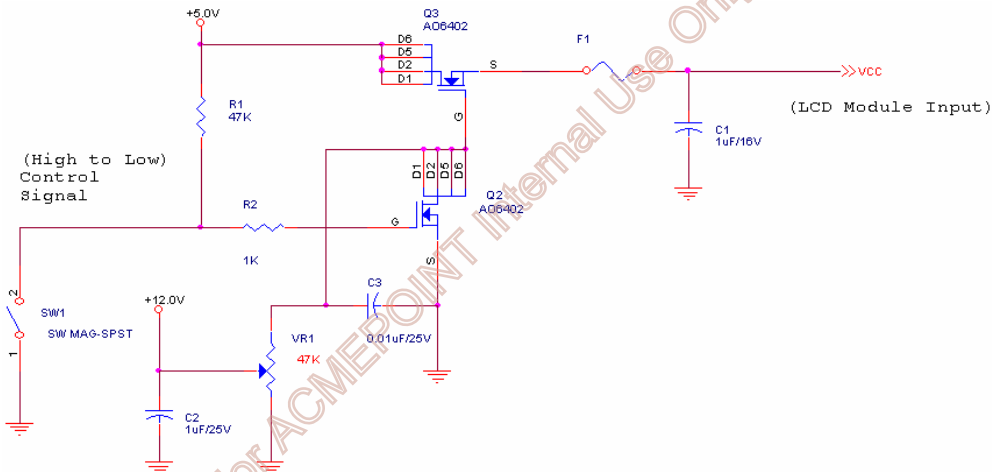

5.1.2 Signal Electrical Characteristics

Input signals shall be low or Hi-Z state when VDD is off. Please refer to specifications of SN75LVDS82DGG (Texas Instruments) in detail.

1. DC Characteristics of each signal are as following:

Symbol	Parameter	Min	Typ	Max	Units	Condition
V_{TH}	Differential Input High Threshold	-	-	+100	[mV]	$V_{ICM} = 1.2V$ Note 1
V_{TL}	Differential Input Low Threshold	-100	-	-	[mV]	$V_{ICM} = 1.2V$ Note 1
$ V_{ID} $	Input Differential Voltage	100	-	600	[mV]	Note 1
V_{ICM}	Differential Input Common Mode Voltage	+1.0	+1.2	+1.5	[V]	$V_{TH}-V_{TL} = 200mV$ (max) Note 1

Note 1: LVDS Signal Waveform

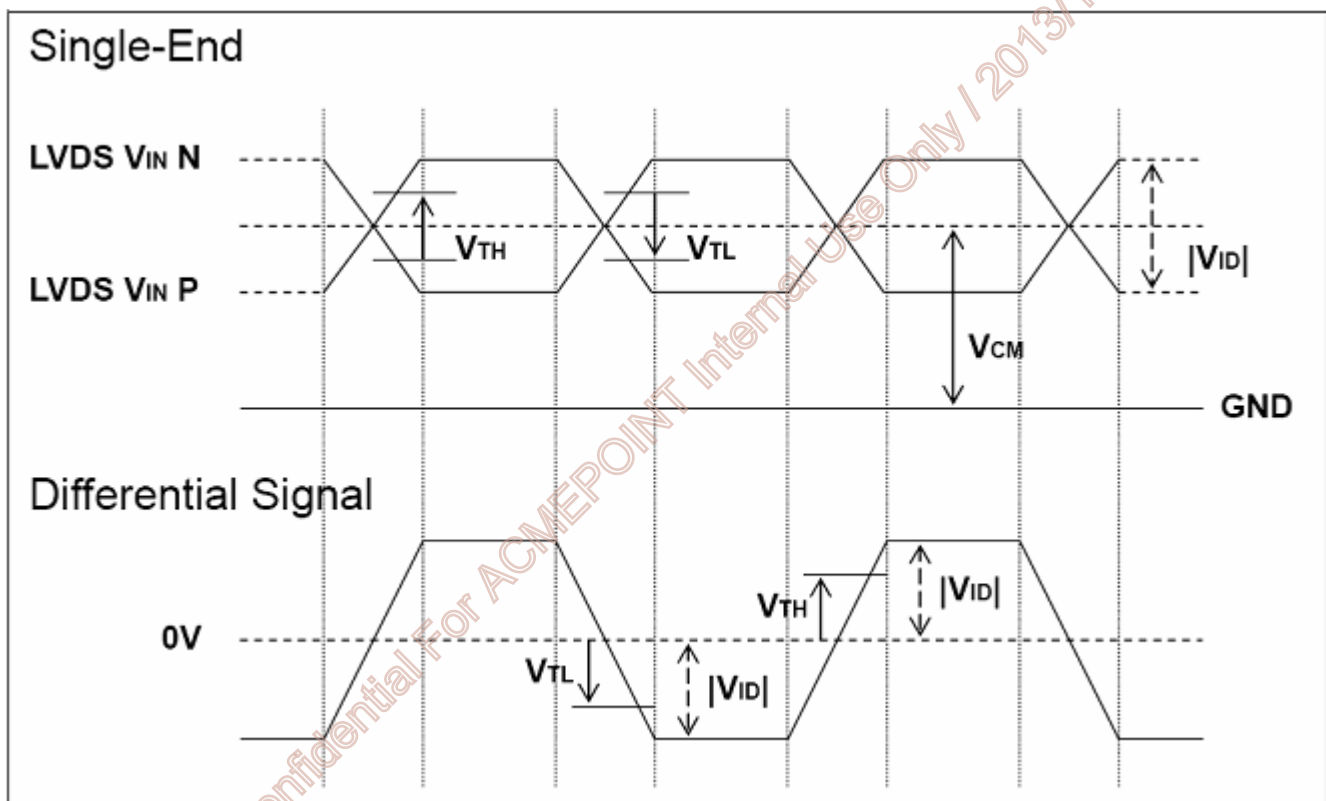

2. AC Characteristics

Description	Symbol	Min	Max	Unit	Note
Maximum deviation of input clock frequency during SSC	F_{DEV}	-	± 3	%	
Maximum modulation frequency of input clock during SSC	F_{MOD}	-	200	KHz	

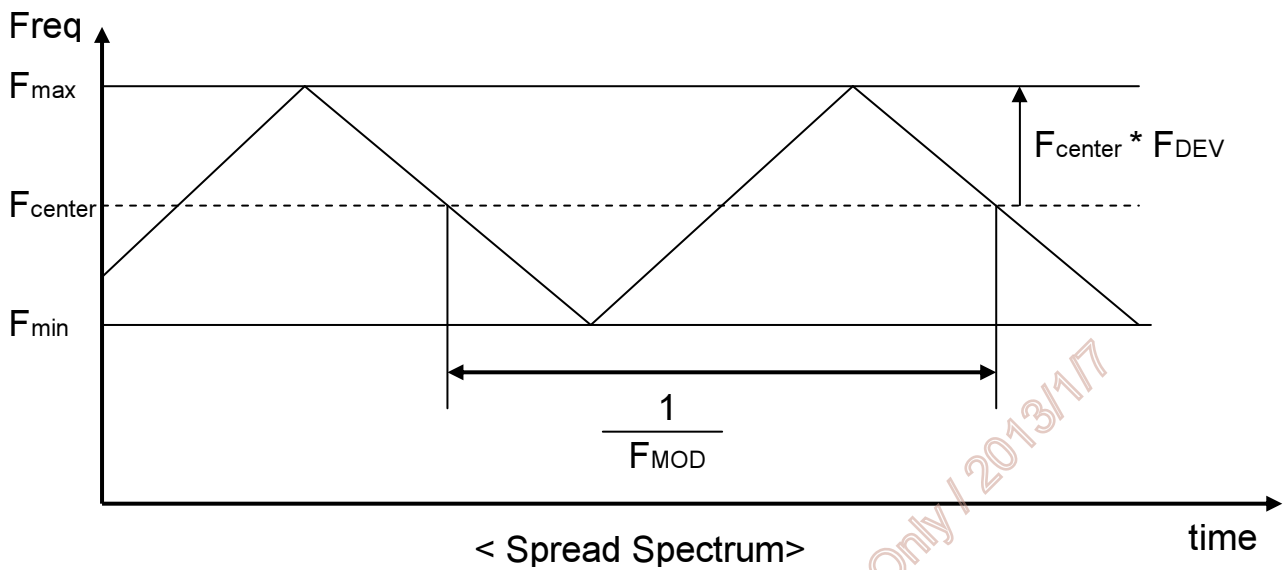

AUO Confidential For ACMEPOINT Internal Use Only / 2013/1/17

5.2 Backlight Unit

Parameter guideline for LED driver is under stable conditions at 25°C (Room Temperature):

Symbol	Parameter	Min.□	Typ.	Max.	Unit	Note
IRLED1	LED Forward Current	-	65	68	mA	Note 1
IRLED2						
IRLED3						
IRLED4						
V _{LB}	Light Bar Operation Voltage (for reference)	30	32	36	[Volt]	Note 2
P _{BLU}	BLU Power consumption (for reference)	-	8.32	9.792	[Watt]	Note 3
LT _{LED}	LED life Time	30000			[Hour]	Note 4

Each module consists of 40 pcs LED (4 strings x 10 pcs / string)

Note 1: The specified current is 100% duty of LED chip input current, IRLED1,2,3,4 define as per strings LED current.

Note 2: The value showed is one string operation voltage.

Note 3: $P_{BLU} = V_{LED} * (IRLED1 + IRLED2 + IRLED3 + IRLED4)$

Note 4: Definition of life time: Brightness becomes to 50% of its original value. The minimum life time of LED unit is on the condition of IRLED = 65mA and 25±2°C (Room Temperature).

6.0 Signal Characteristic

6.1 Pixel Format Image

Following figure shows the relationship of the input signals and LCD pixel format.

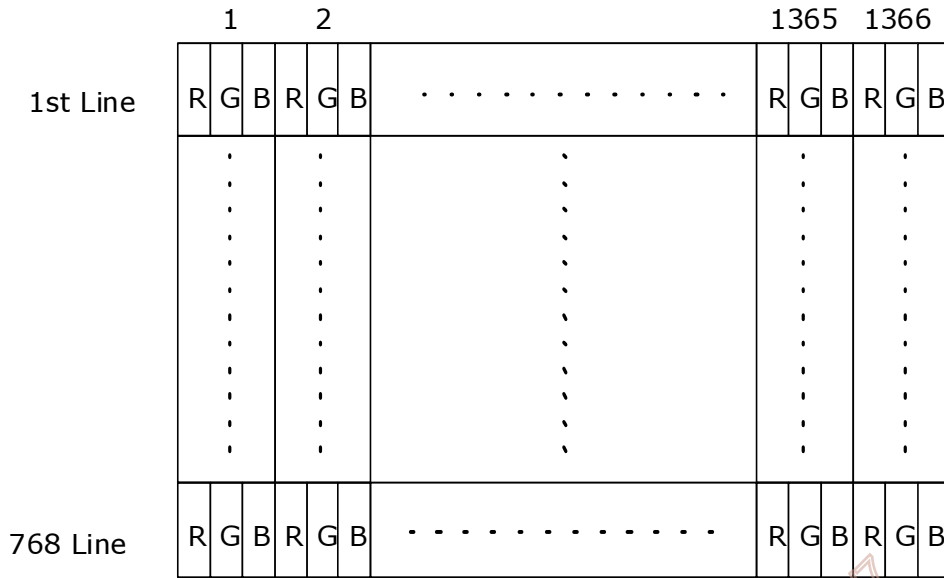

6.2 The input data format

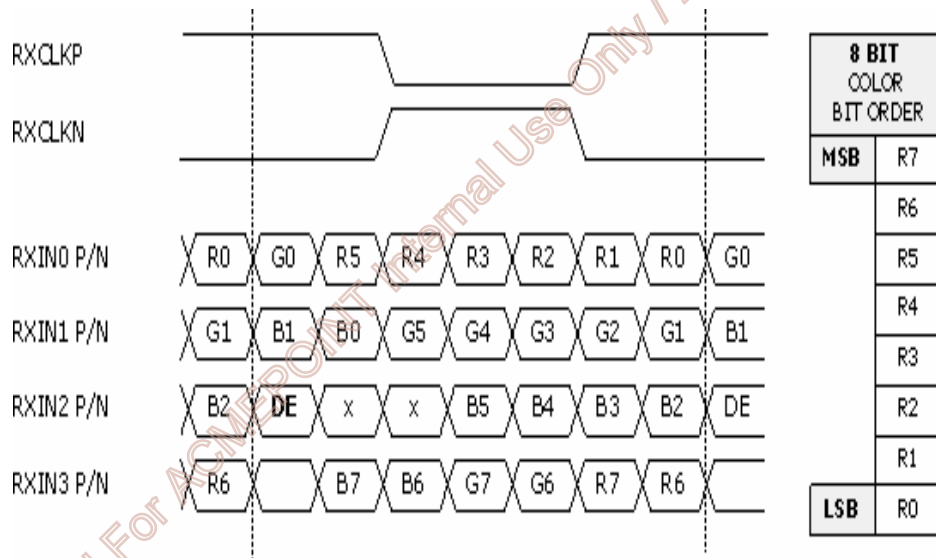

Note1: Normally, DE, VS, HS on EVEN channel are not used.

Note2: 8-bits signal input.

6.3 Signal Description

PIN #	SIGNAL NAME	DESCRIPTION
1	NC	No contact (For AUO internal use)
2	NC	No contact (For AUO internal use)
3	NC	No contact (For AUO internal use)
4	GND	Power Ground
5	RXIN0-	Negative LVDS differential data input (0)
6	RXIN0+	Positive LVDS differential data input (0)
7	GND	Power Ground
8	RXIN1-	Negative LVDS differential data input (1)
9	RXIN1+	Positive LVDS differential data input (1)
10	GND	Power Ground
11	RXIN2-	Negative LVDS differential data input (2)
12	RXIN2+	Positive LVDS differential data input (2)
13	GND	Power Ground
14	RXCLKIN-	Negative LVDS differential clock input (clock)
15	RXCLKIN+	Positive LVDS differential data input (clock)
16	GND	Power Ground
17	RXIN3-	Negative LVDS differential data input (3)
18	RXIN3+	Positive LVDS differential data input (3)
19	GND	Power Ground
20	NC	No contact (For AUO internal use)
21	NC	No contact (For AUO internal use)
22	NC	No contact (For AUO internal use)
23	GND	Power Ground
24	GND	Power Ground
25	GND	Power Ground
26	VCC	+5V power supply
27	VCC	+5V power supply
28	VCC	+5V power supply
29	VCC	+5V power supply
30	VCC	+5V power supply

Note 1: Input signals of odd and even clock shall be the same timing.

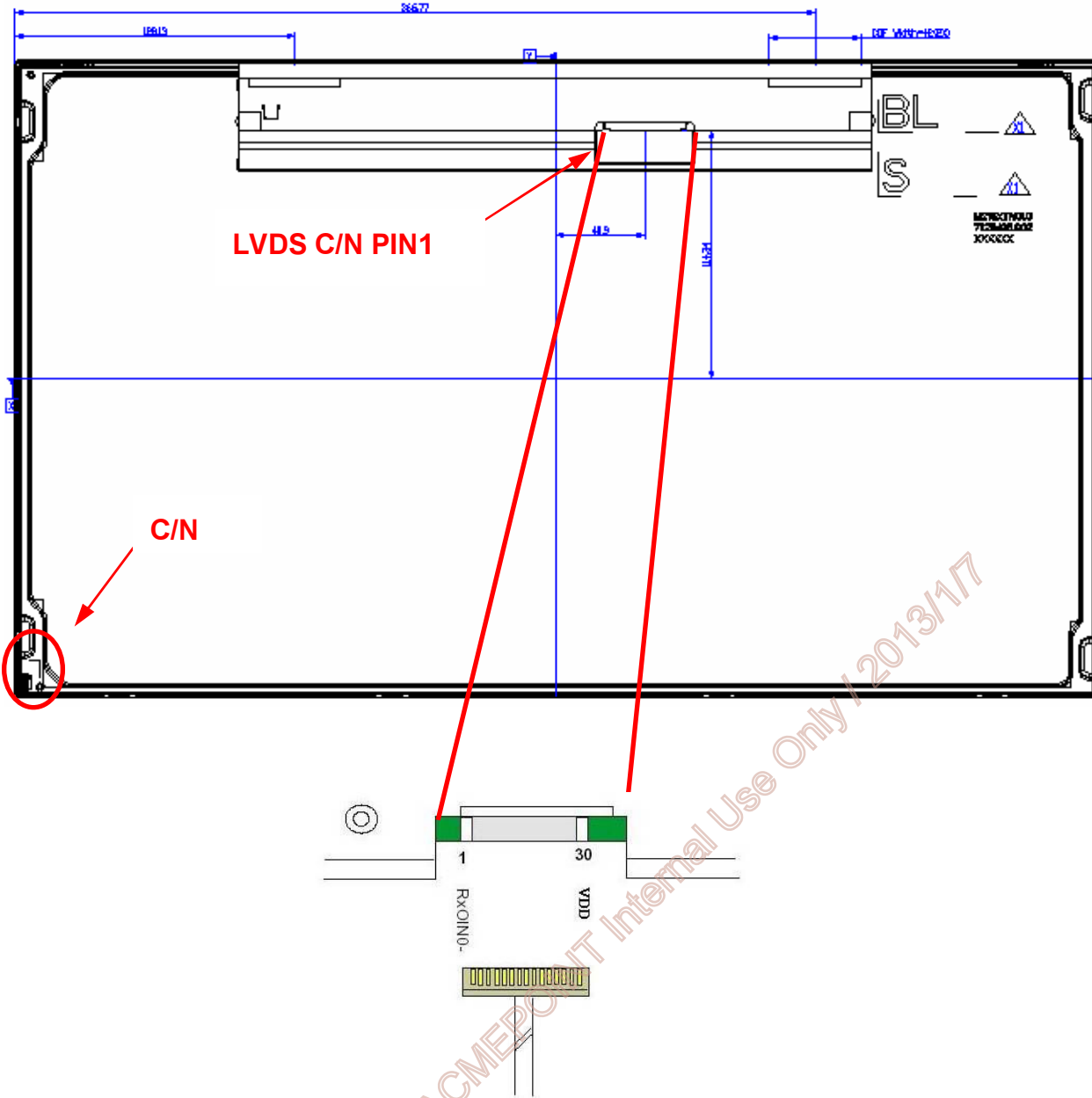

6.4 Timing Characteristics

The input signal timing specifications are shown as the following table

Signal	Item	Symbol	Min	Typ	Max	Unit
Vertical Section	Period	T_v	793	808	1293	Th
	Active	$T_{disp(v)}$	768	768	768	Th
	Blanking	$T_{bp(v)}+T_{fp(v)}+PW_{vs}$	25	40	525	Th
Horizontal Section	Period	T_h	1454	1606	2047	Tclk
	Active	$T_{disp(h)}$	1366	1366	1366	Tclk
	Blanking	$T_{bp(h)}+T_{fp(h)}+PW_{hs}$	88	240	681	Tclk
Clock	Period	Tclk	10.6	12.8	17.4	ns
	Frequency	Freq	58	78	94	MHz
Frame rate	Frame rate	F	50	60	75	Hz
Hsync Frequency	Hsync Frequency	HFreq	72	96	153	KHz

Note : DE mode only

6.5 Timing diagram

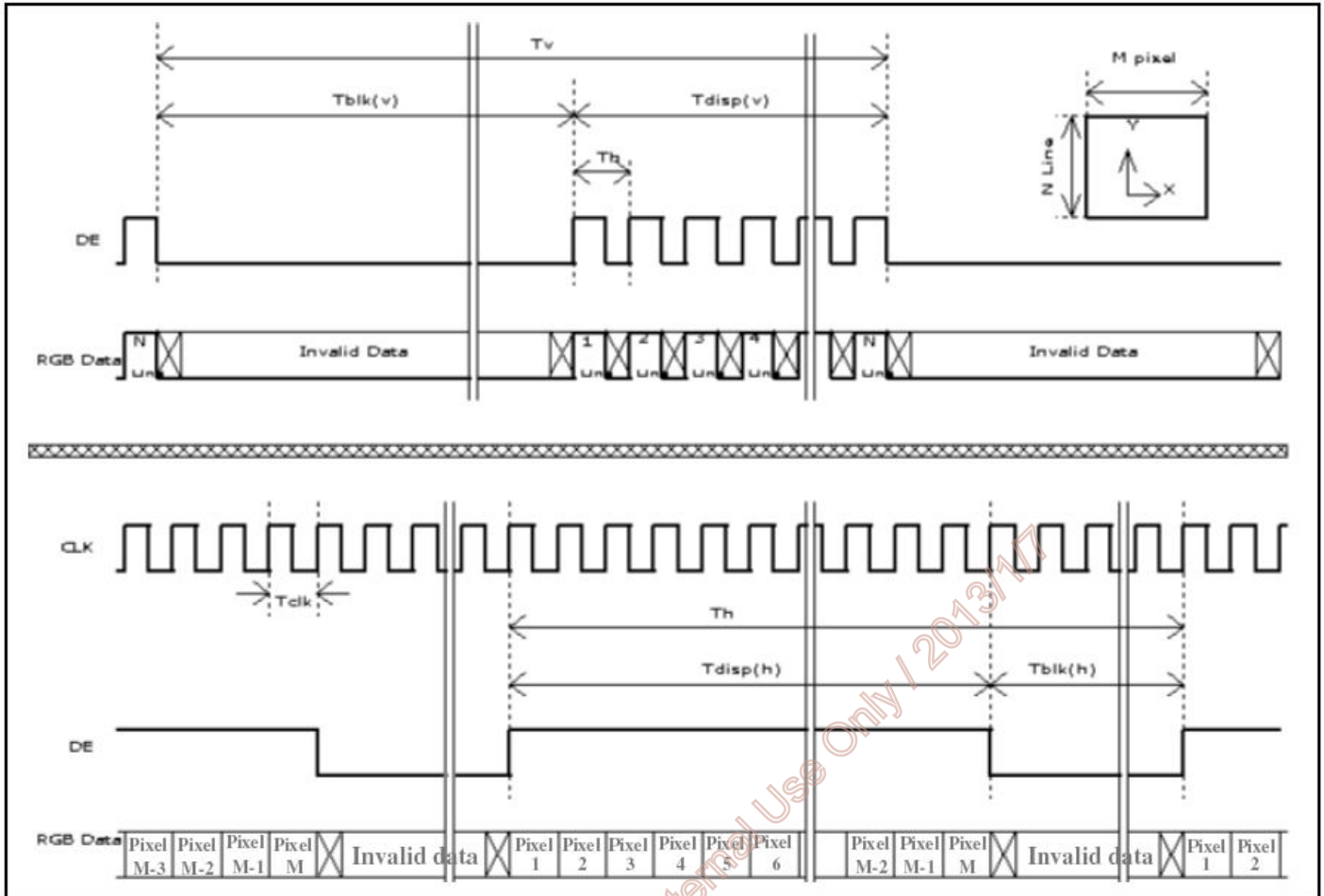

AUO Confidential For ACMEPOINT Internal Use Only / 2013/1/17

6.6 Power ON/OFF Sequence

VDD power and lamp on/off sequence are as follows. Interface signals are also shown in the chart. Signals from any system shall be Hi-Z state or low level when VDD is off.

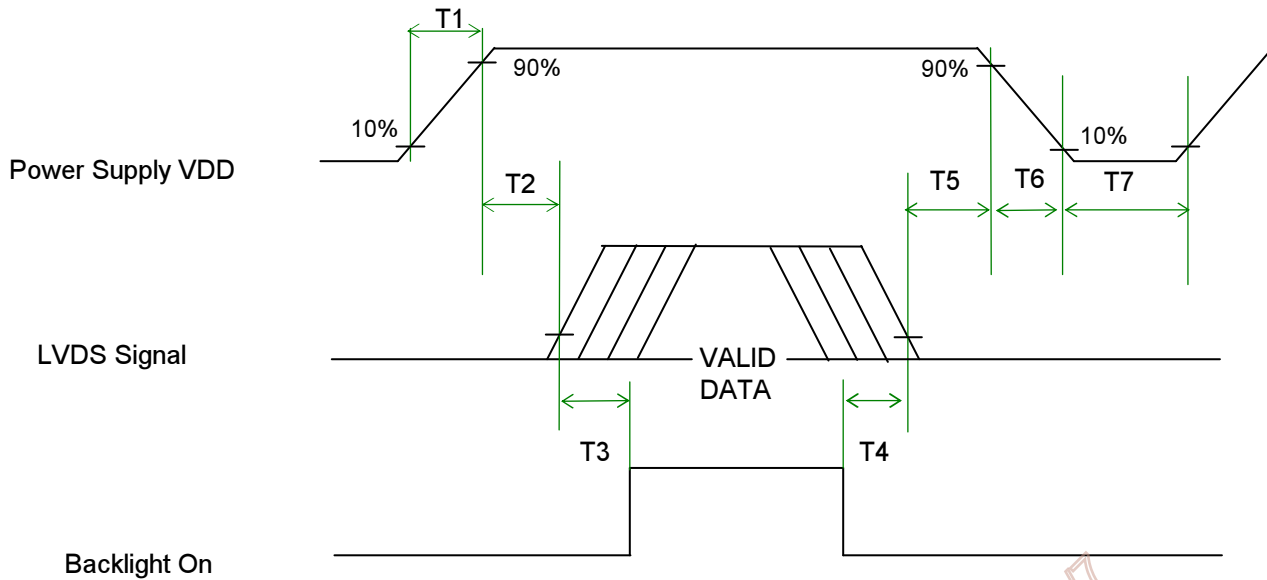

Parameter	Value			Unit
	Min.	Typ.	Max.	
T1	0.5	-	10	[ms]
T2	0	-	50	[ms]
T3	500	-	-	[ms]
T4	100	-	-	[ms]
T5	0	-	50	[ms] Note1,2
T6	5	-	100	[ms] Note1,2
T7	1000	-	-	[ms]

Note1 : Recommend setting T5 = 0ms to avoid electronic noise when VDD is off.

Note2 : During T5 and T6 period , please keep the level of input LVDS signals with Hi-Z state.

7.0 Connector & Pin Assignment

Physical interface is described as for the connector on module. These connectors are capable of accommodating the following signals and will be following components.

7.1 TFT LCD Module

Connector Name / Designation	Interface Connector / Interface card
Manufacturer	STM & P-TWO
Type Part Number	MSCKT2407P30HB / AL230F-A0G1D-P
Mating Housing Part Number	FI-X30HL (Locked Type)

7.1.1 Pin Assignment

Pin#	Signal Name	Pin#	Signal Name
1	NC(for AUO test only. Do not connect)	2	NC(for AUO test only. Do not connect)
3	NC(for AUO test only. Do not connect)	4	GND
5	RXIN0-	6	RXIN0+
7	GND	8	RXIN1-
9	RXIN1+	10	GND
11	RXIN2-	12	RXIN2+
13	GND	14	RXCLKIN-
15	RXCLKIN+	16	GND
17	RXIN3-	18	RXIN3+
19	GND	20	NC(for AUO test only. Do not connect)
21	NC(for AUO test only. Do not connect)	22	NC(for AUO test only. Do not connect)
23	GND	24	GND
25	GND	26	VCC
27	VCC	28	VCC
29	VCC	30	VCC

7.2 LED Connector on Backlight Unit

This connector is mounted on LED light-bar.

Connector Name / Designation	Light Bar Connector
Manufacturer	ENTERY
Type Part Number	3707K-S06N-21R

7.2.1 LED Pin assignment

Pin no.	Signal name
1	IRLED1 (current out)
2	IRLED2 (current out)
3	VLED (voltage in)
4	VLED (voltage in)
5	IRLED3 (current out)
6	IRLED4 (current out)

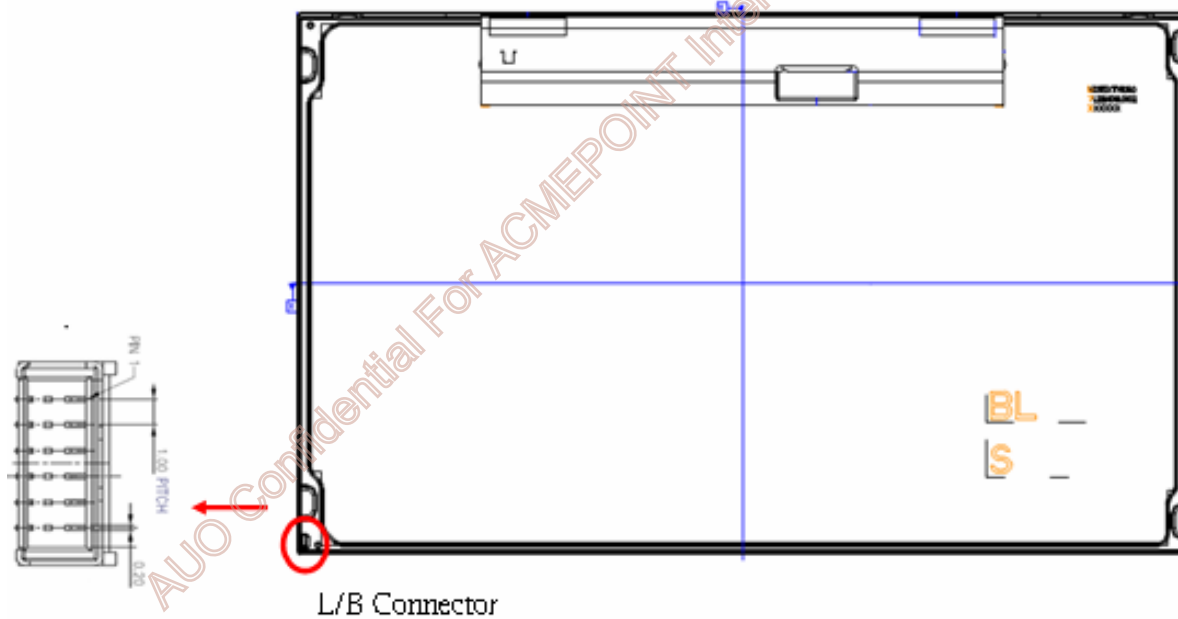

L/B Connector

7.2.2 LED Connector Dimension

$H \times V \times D = 13.9 \times 3.00 \times 4.25$, Pitch = 1.0 (unit = mm)

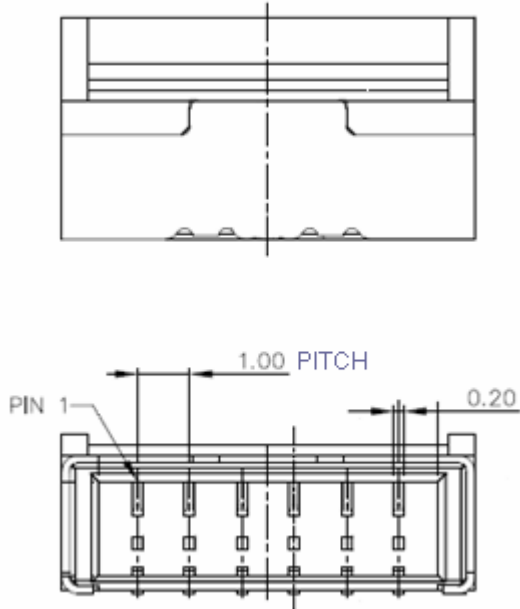

7.2.3 LED Mating housing dimension

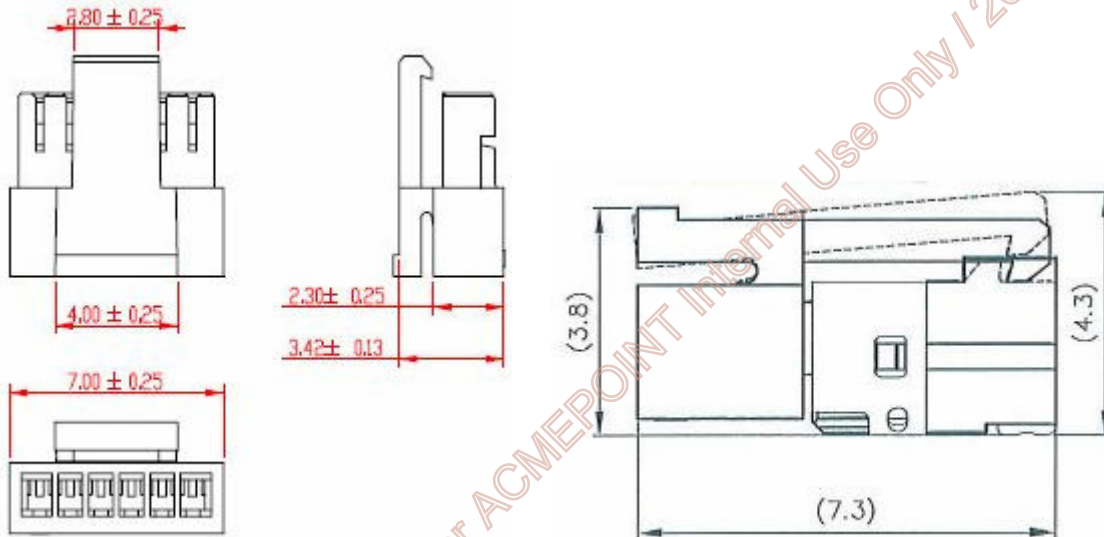

AUO Confidential For ACMEPOINT Internal Use Only / 2013/1/17

8.0 Reliability Test

Environment test conditions are listed as following table.

Items	Required Condition	Note
Temperature Humidity Bias (THB)	Ta= 50□, 80%RH, 300hours	
High Temperature Operation (HTO)	Ta= 50□, 50%RH, 300hours	
Low Temperature Operation (LTO)	Ta= 0□, 300hours	
High Temperature Storage (HTS)	Ta= 60□, 300hours	
Low Temperature Storage (LTS)	Ta= -20□, 300hours	
Vibration Test (Non-operation)	Acceleration: 1.5 Grms Wave: Random Frequency: 10 - 200 Hz Sweep: 30 Minutes each Axis (X, Y, Z)	
Shock Test (Non-operation)	Acceleration: 50 G Wave: Half-sine Active Time: 20 ms Direction: ±X, ±Y, ±Z (one time for each Axis)	
Drop Test	Height: 60 cm, package test	
Thermal Shock Test (TST)	-20□/30min, 60□/30min, 100 cycles	1
On/Off Test	On/10sec, Off/10sec, 30,000 cycles	
ESD (Electro Static Discharge)	Contact Discharge: ± 15KV, 150pF(330Ω) 1sec, 7 points, 25 times/ point.	2
	Air Discharge: ± 15KV, 150pF(330Ω) 1sec 7 points, 25 times/ point.	
Altitude Test	Operation:18,000 ft Non-Operation:40,000 ft	

Note 1: The TFT-LCD module will not sustain damage after being subjected to 100 cycles of rapid temperature change. A cycle of rapid temperature change consists of varying the temperature from -20□ to 60□, and back again. Power is not applied during the test. After temperature cycling, the unit is placed in normal room ambient for at least 4 hours before power on.

Note 2: EN61000-4-2, ESD class B: Certain performance degradation allowed

- No data lost
- Self-recoverable
- No hardware failures.

9.0 Shipping Label

The label is on the panel as shown below:

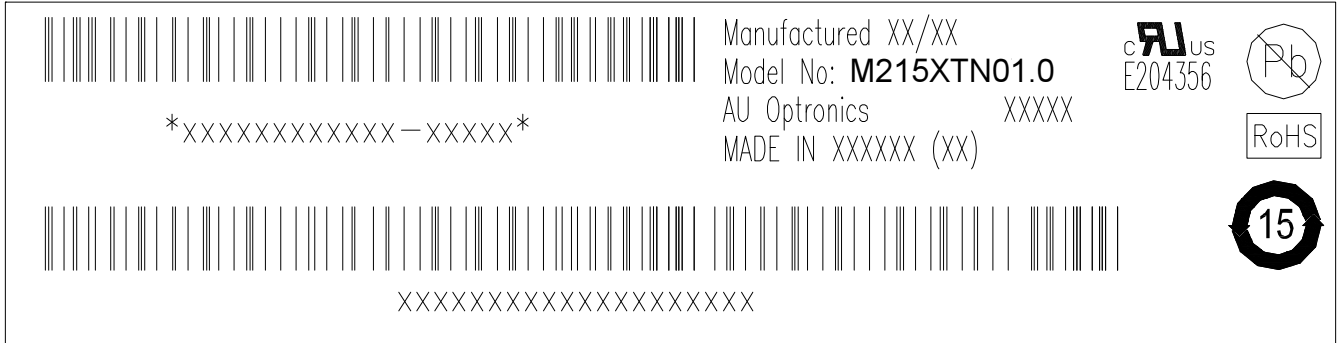

Note 1: For Pb Free products, AUO will add  for identification.

Note 2: For RoHS compatible products, AUO will add  for identification.

Note 3: For China RoHS compatible products, AUO will add  for identification.

Note 4: The Green Mark will be presented only when the green documents have been ready by AUO Internal Green Team.

AUO Confidential For ACMEPPOINT Internal Use Only / 2013/11/17

10.0 Mechanical Characteristics

NOTES:

1. BACKLIGHT: LED LIGHT BAR.
2. I/F CONNECTOR: FL-XP803SLA-HF11.
3. TOLERANCE WITHOUT SPECIFIED TO BE 0.5 mm.
4. DIMENSIONS IN PARENTHESES ARE FOR REFERENCE ONLY.
5. THIS DIMENSION EXCLUDES THE THICKNESS OF THE USER HOLE.
6. TORQUE OF M3 USER HOLE NUTS SHOULD BE WITHIN 4 KGF-CM AND RE-SCREW 10 TIMES.

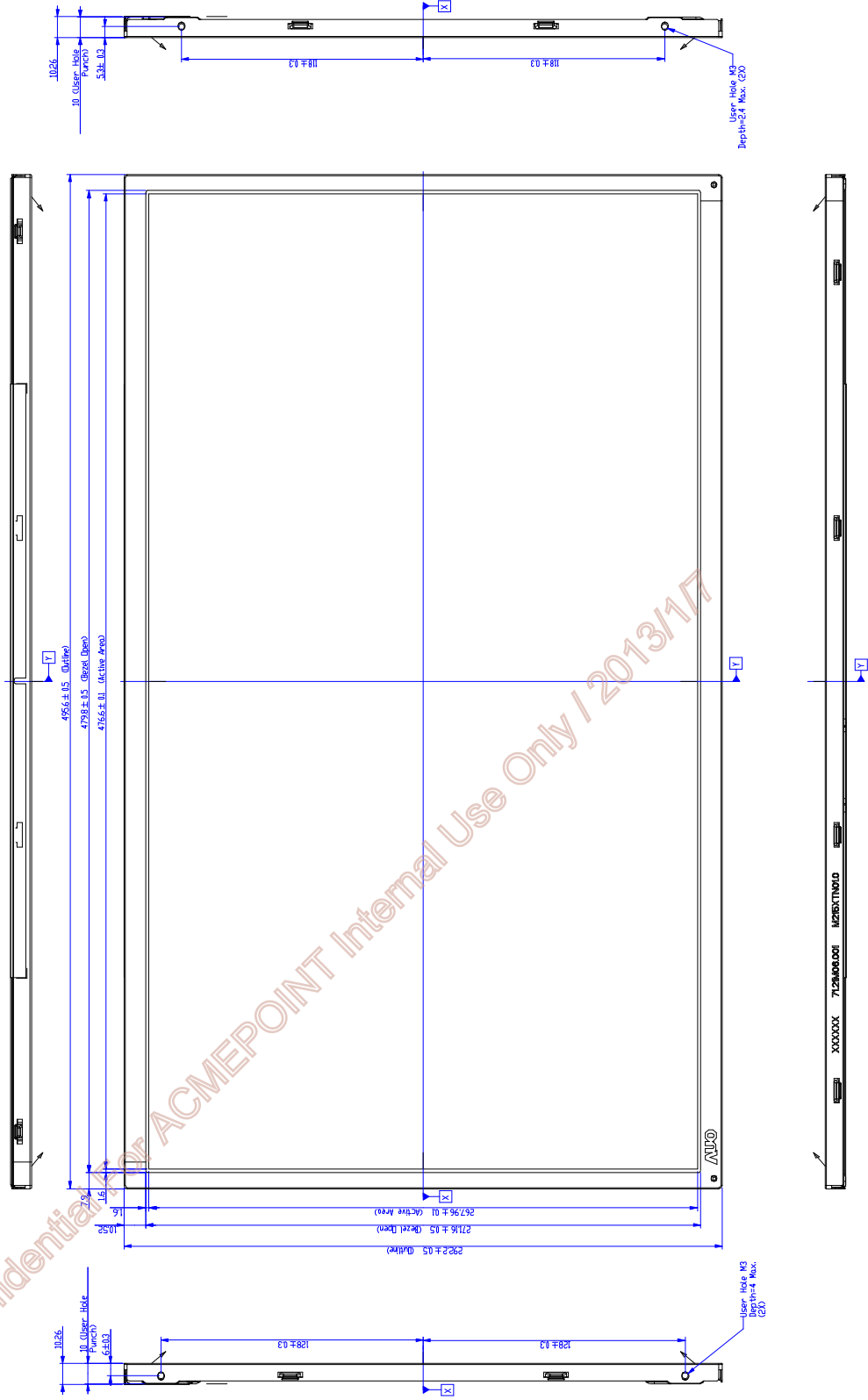

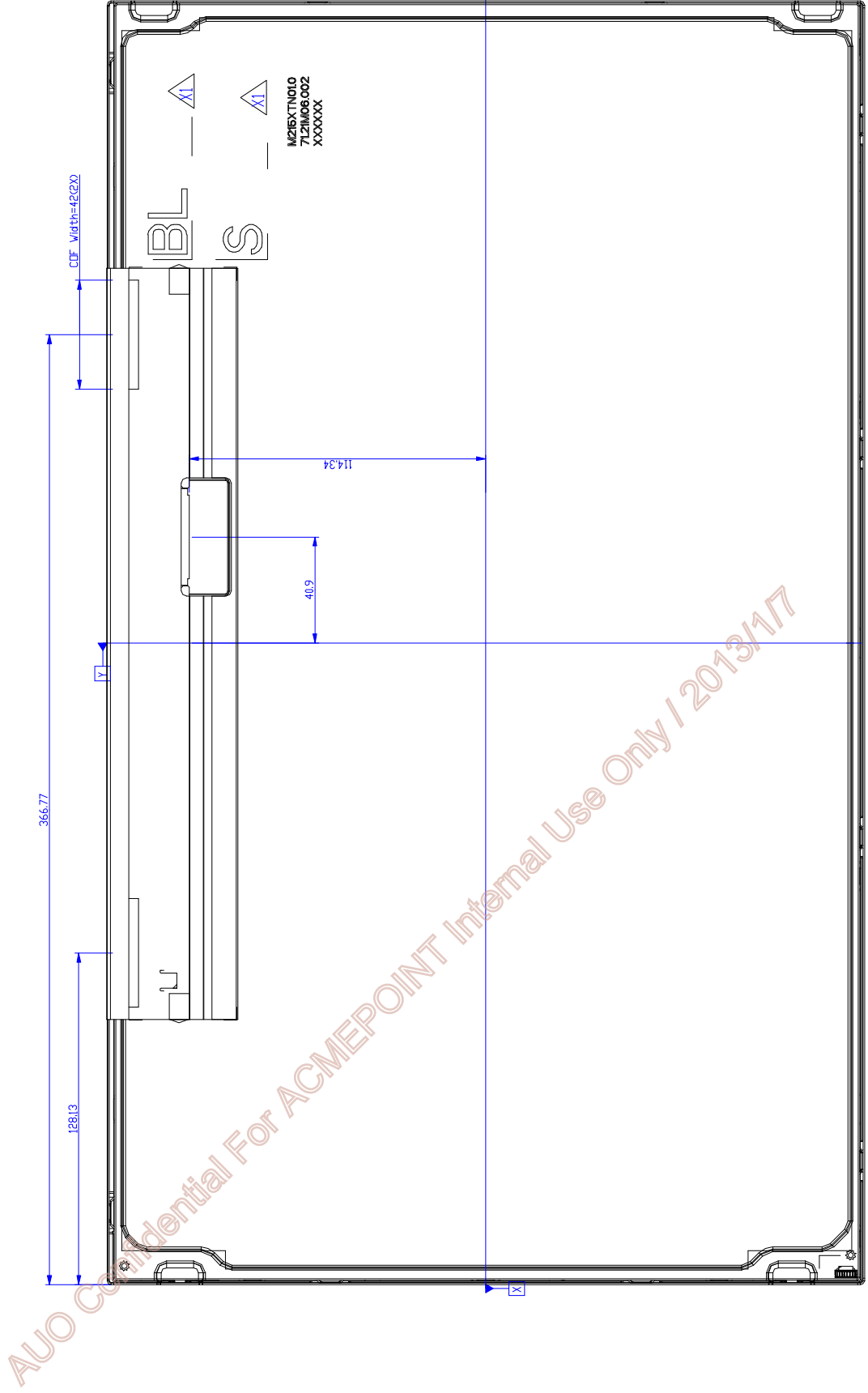

11. Packing Specification

11.1 Packing Flow

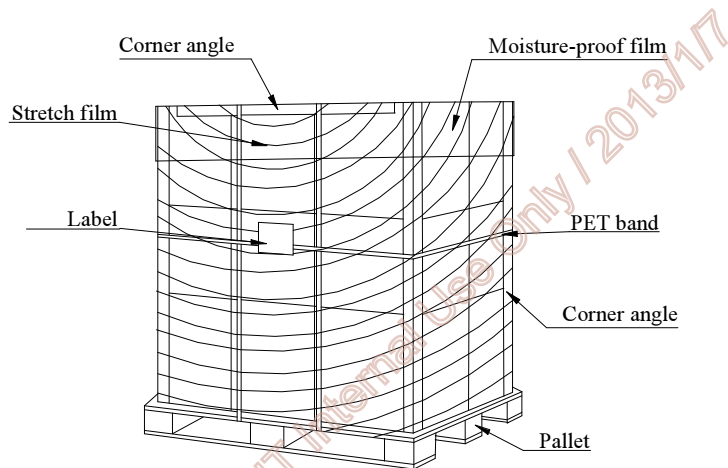
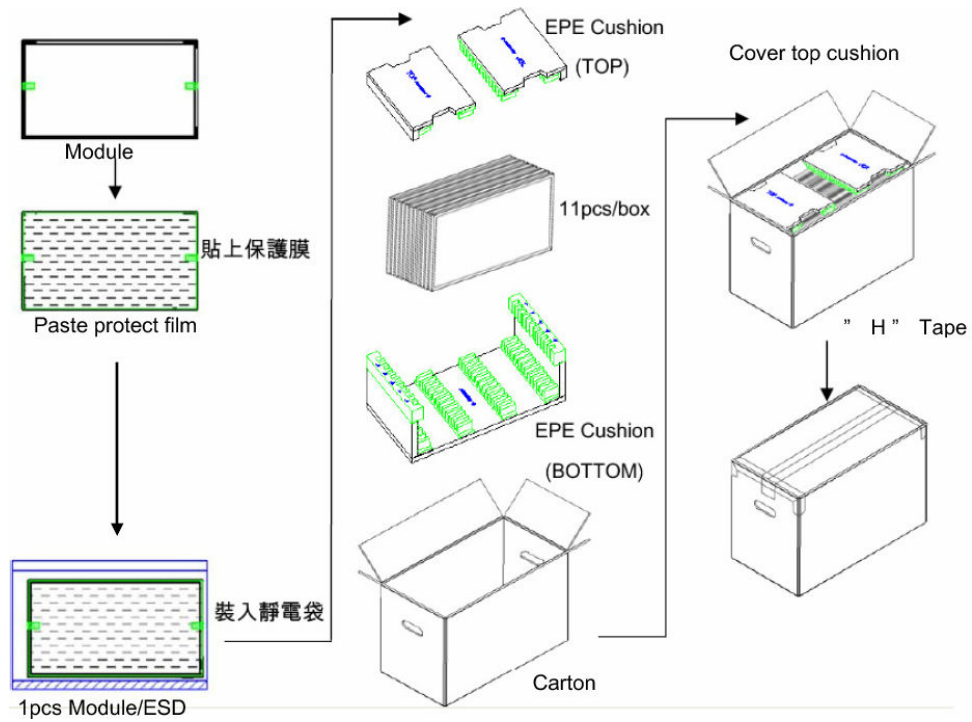

11.2. Pallet and shipment information

	Item	Specification			Remark
		Q'ty	Dimension	Weight(kg)	
1	Panel	1	495.6(W)mm × 292.2(H)mm × 10(D)mm	1.80	
2	Cushion	1	-	0.40	
3	Box	1	556(L)mm x 292(W)mm x 375(H)mm	0.95	without Panel & cushion
4	Packing Box	11 pcs/Box	556(L)mm x 292(W)mm x 375(H)mm	21.15	with panel & cushion
5	Pallet	1	1150(L)mm x 910(W)mm x 132(H)mm	12.00	
6	Pallet after Packing	18 boxes/pallet	1150(L)mm x 910(W)mm x 1257(H)mm	392.70	