



Approval

TFT LCD Approval Specification

MODEL NO.: M220J1-L01

www.panelook.com

- CONTENTS -

REVISION HISTORY	-----	3
1. GENERAL DESCRIPTION	-----	4
1.1 OVERVIEW		
1.2 FEATURES		
1.3 APPLICATION		
1.4 GENERAL SPECIFICATIONS		
1.5 MECHANICAL SPECIFICATIONS		
2. ABSOLUTE MAXIMUM RATINGS	-----	5
2.1 ABSOLUTE RATINGS OF ENVIRONMENT		
2.2 ELECTRICAL ABSOLUTE RATINGS		
2.2.1 TFT LCD MODULE		
2.2.2 BACKLIGHT UNIT		
3. ELECTRICAL CHARACTERISTICS	-----	7
3.1 TFT LCD MODULE		
3.2 V _{CC} POWER DIP CONDITION		
3.3 BACKLIGHT UNIT		
4. BLOCK DIAGRAM	-----	11
4.1 TFT LCD MODULE		
4.2 BACKLIGHT UNIT		
5. INPUT TERMINAL PIN ASSIGNMENT	-----	12
5.1 TFT LCD MODULE		
5.2 LVDS DATA MAPPING TABLE		
5.3 BACKLIGHT UNIT		
5.4 COLOR DATA INPUT ASSIGNMENT		
6. INTERFACE TIMING	-----	15
6.1 INPUT SIGNAL TIMING SPECIFICATIONS		
6.2 POWER ON/OFF SEQUENCE		
7. OPTICAL CHARACTERISTICS	-----	17
7.1 TEST CONDITIONS		
7.2 OPTICAL SPECIFICATIONS		
8. PACKAGING	-----	20
8.1 PACKING SPECIFICATIONS		
8.2 PACKING METHOD		
9. DEFINITION OF LABELS	-----	22
9.1 CMO MODULE LABEL		
10. PRECAUTIONS	-----	24
10.1 ASSEMBLY AND HANDLING PRECAUTIONS		
10.2 SAFETY PRECAUTIONS		
11. MECHANICAL CHARACTERISTICS	-----	25

REVISION HISTORY

Version	Date	Section	Description
---------	------	---------	-------------

www.panelook.com

1. GENERAL DESCRIPTION

1.1 OVERVIEW

The M220J1-L01 model is a 22 inch wide TFT-LCD module with a 4-CCFL Backlight Unit and a 30-pin 2ch-LVDS interface. This module supports 1920 x 1200 WUXGA (16:10 wide screen) mode and displays up to 16.7 millions colors. The inverter module for the Backlight Unit is not built in.

1.2 FEATURES

- Super wide viewing angle
- High contrast ratio
- Fast response time
- High color saturation (EBU Like Specifications)
- WUXGA (1920 x 1200 pixels) resolution
- DE (Data Enable) only mode
- LVDS (Low Voltage Differential Signaling) interface

1.3 APPLICATION

- Workstation & desktop monitor
- Display terminals for AV application

1.4 GENERAL SPECIFICATIONS

Item	Specification	Unit	Note
Diagonal size	558.68	mm	
Active Area	473.76x296.1	mm	(1)
Bezel Opening Area	477.7 (H) x 300.1 (V)	mm	
Driver Element	a-Si TFT active matrix	-	-
Pixel Number	1920 x R.G.B. x 1200	pixel	-
Pixel Pitch	0.247(H) x 0.247(V)	mm	-
Pixel Arrangement	RGB vertical stripe	-	-
Display Colors	16.7 millions	color	-
Transmissive Mode	Normally White	-	-
Surface Treatment	Hard coating (3H), AG (Haze 25%)	-	-

1.5 MECHANICAL SPECIFICATIONS

Item	Min.	Typ.	Max.	Unit	Note	
Module Size	Horizontal(H)	493.2	493.7	494.2	mm	(1)
	Vertical(V)	319.6	320.1	320.6	mm	
	Depth(D)	16	16.5	17	mm	
Weight			2550	g		
I/F connector mounting position	The mounting inclination of the connector makes the screen center within ± 0.5 mm as the horizontal.					

Note (1) Please refer to the attached drawings for more information of front and back outline dimensions.

2. ABSOLUTE MAXIMUM RATINGS

2.1 ABSOLUTE RATINGS OF ENVIRONMENT

Item	Symbol	Value		Unit	Note
		Min.	Max.		
Storage Temperature	T _{ST}	-20	+60	°C	(1)
Operating Ambient Temperature	T _{OP}	0	+50	°C	(1), (2)
Shock (Non-Operating)	S _{NOP}	-	50	G	(3), (5)
Vibration (Non-Operating)	V _{NOP}	-	1	G	(4), (5)
LCD Cell Life Time	L _{CELL}	50,000	-	Hrs	MTBF based

2.2 ELECTRICAL ABSOLUTE RATINGS**2.2.1 TFT LCD MODULE**

Item	Symbol	Value		Unit	Note
		Min.	Max.		
Power Supply Voltage	Vcc	-0.3	+6	V	(1)

2.2.2 BACKLIGHT UNIT

Item	Symbol	Value		Unit	Note
		Min.	Max.		
Lamp Voltage	V_L	-	2.5K	V_{RMS}	(1), (2), $I_L = 7.0$ mA
Lamp Current	I_L	3.0	8.0	mA_{RMS}	(1), (2)
Lamp Frequency	F_L	40	80	KHZ	

Note (1) Permanent damage to the device may occur if maximum values are exceeded. Function operation should be restricted to the conditions described under Normal Operating Conditions.

Note (2) Specified values are for lamp (Refer to 3.2 for further information).

3. ELECTRICAL CHARACTERISTICS

3.1 TFT LCD MODULE

Ta = 25 ± 2 °C

Parameter	Symbol	Value			Unit	Note
		Min.	Typ.	Max.		
Power Supply Voltage	Vcc	4.5	5.0	5.5	V	-
Ripple Voltage	V _{RP}	-	--	100	mV	-
Rush Current	I _{RUSH}	-	--	3	A	(2)
Power Supply Current	White	-	590	710	mA	(3)a
	Black	-	950	1150	mA	(3)b
	Vertical Stripe	-	860	1050	mA	(3)c
LVDS differential input voltage	V _{id}	200	-	600	mV	
LVDS common input voltage	V _{ic}	--	0.8	--	V	

Note (1) The module should be always operated within above ranges.

Note (2) Measurement Conditions:

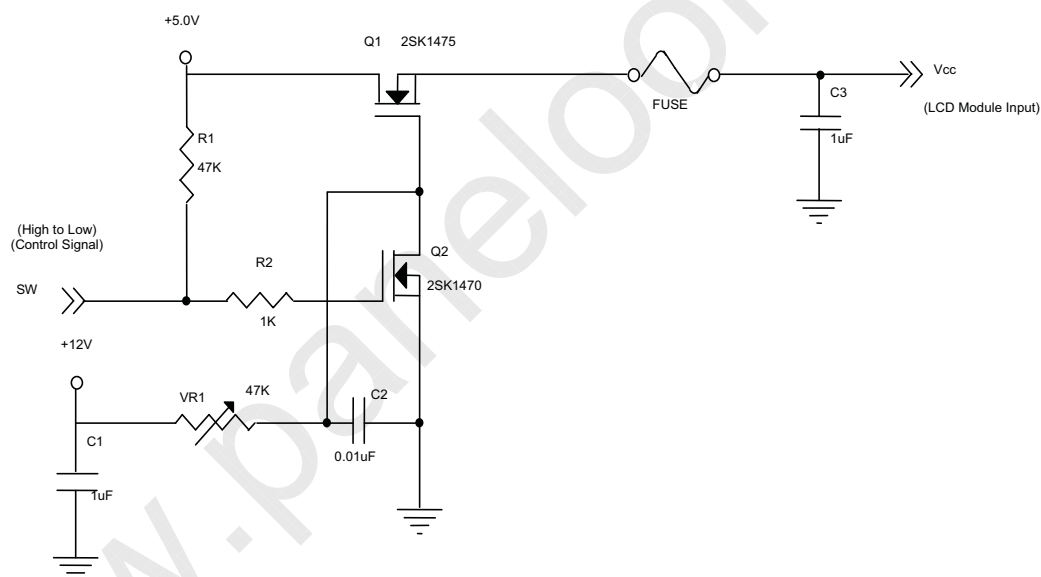

Vcc rising time is 470µs

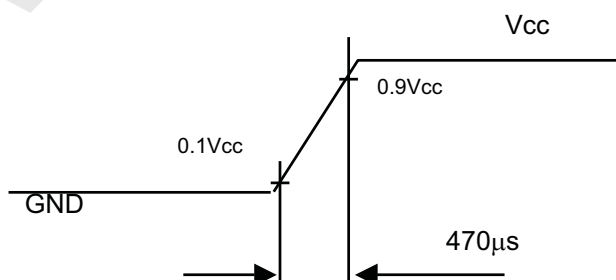

Note (3) The specified power supply current is under the conditions at $V_{cc} = 5.0\text{ V}$, $T_a = 25 \pm 2\text{ }^\circ\text{C}$, $f_v = 60\text{ Hz}$, whereas a power dissipation check pattern below is displayed.

a. White Pattern



Active Area

b. Black Pattern



Active Area

c. Vertical Stripe Pattern

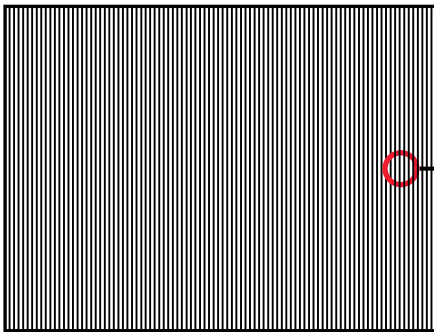

Active Area

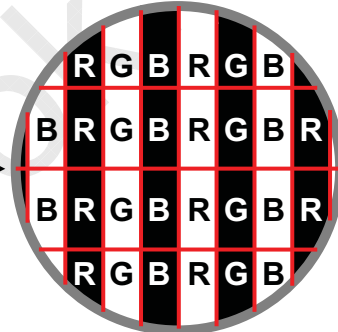

3.2 Vcc Power Dip Condition:

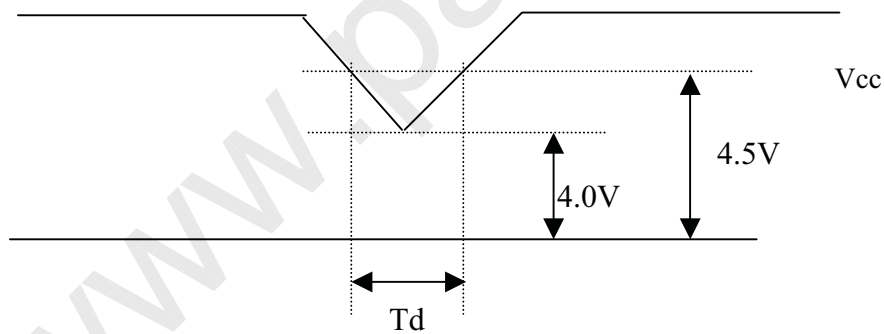

Dip condition: $4.0\text{ V} \leq V_{cc} \leq 4.5\text{ V}$, $T_d \leq 20\text{ ms}$

3.3 BACKLIGHT UNIT

Parameter	Symbol	Value			Unit	Note
		Min.	Typ.	Max.		
Lamp Input Voltage	V_L	738	820	902	V_{RMS}	$I_L = (7.0) \text{ mA}$
Lamp Current	I_L	3	7.0	8	mA_{RMS}	(1)
Lamp Turn On Voltage	V_s	-	-	1720(25°C)	V_{RMS}	(2)
		-	-	1940(0°C)	V_{RMS}	(2)
Operating Frequency	F_L	40	60	80	KHz	(3)
Lamp Life Time	L_{BL}	50000		-	Hrs	(5) $I_L = (7.0) \text{ mA}$
Power Consumption	P_L	-	22.96	-	W	(4), $I_L = (7.0) \text{ mA}$



Approval

www.panelook.com

4. BLOCK DIAGRAM

4.1 TFT LCD MODULE

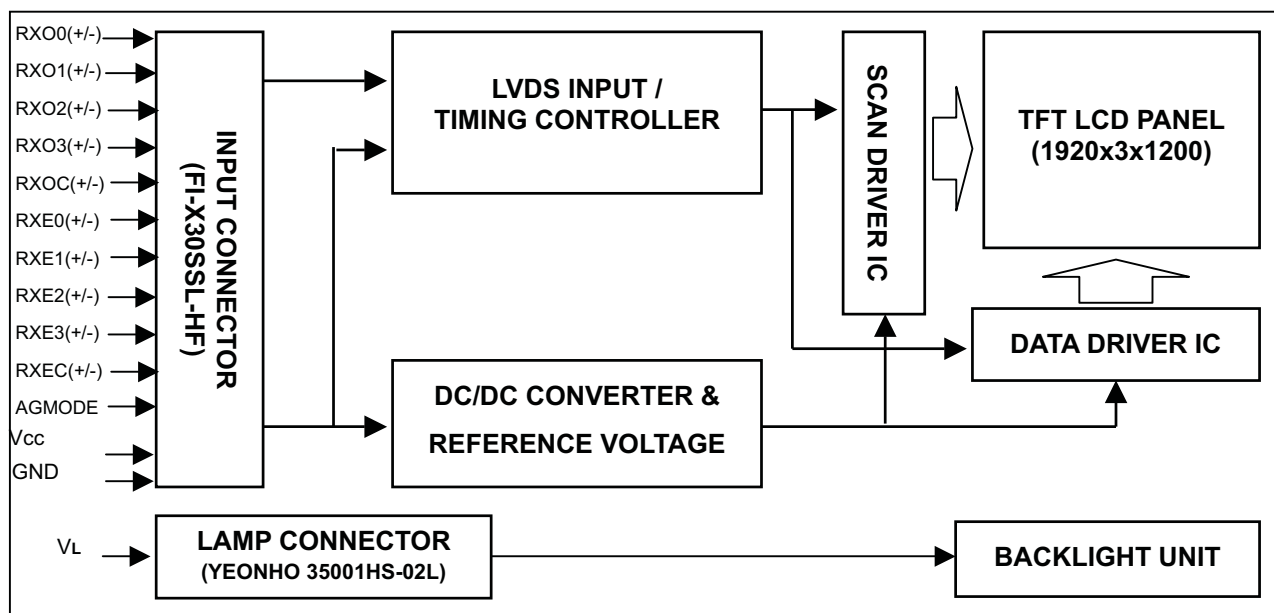

4.2 BACKLIGHT UNIT

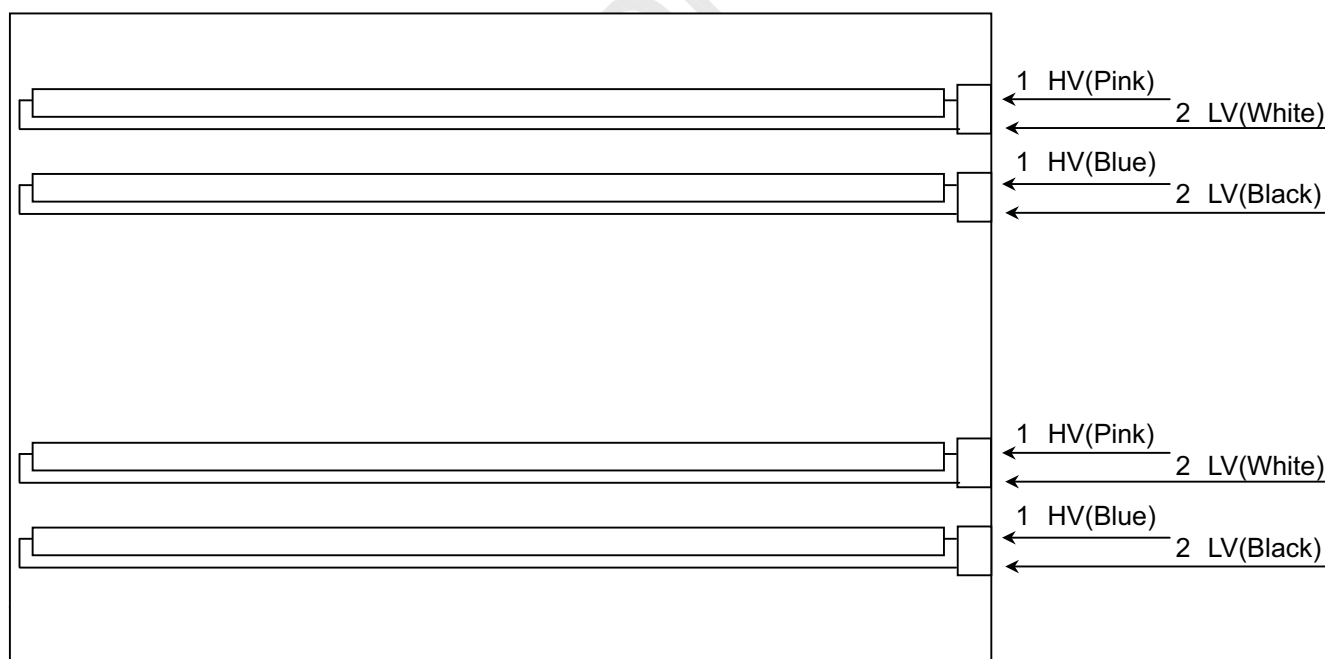

Note: On the same side, the same-polarity lamp voltage design for lamps is recommended

5. INPUT TERMINAL PIN ASSIGNMENT

5.1 TFT LCD MODULE

Pin	Name	Description
1	RXO0-	Negative LVDS differential data input. Channel O0 (odd)
2	RXO0+	Positive LVDS differential data input. Channel O0 (odd)
3	RXO1-	Negative LVDS differential data input. Channel O1 (odd)
4	RXO1+	Positive LVDS differential data input. Channel O1 (odd)
5	RXO2-	Negative LVDS differential data input. Channel O2 (odd)
6	RXO2+	Positive LVDS differential data input. Channel O2 (odd)
7	GND	Ground
8	RXOC-	Negative LVDS differential clock input. (odd)
9	RXOC+	Positive LVDS differential clock input. (odd)
10	RXO3-	Negative LVDS differential data input. Channel O3(odd)
11	RXO3+	Positive LVDS differential data input. Channel O3 (odd)
12	RXE0-	Negative LVDS differential data input. Channel E0 (even)
13	RXE0+	Positive LVDS differential data input. Channel E0 (even)
14	GND	Ground
15	RXE1-	Negative LVDS differential data input. Channel E1 (even)
16	RXE1+	Positive LVDS differential data input. Channel E1 (even)
17	GND	Ground
18	RXE2-	Negative LVDS differential data input. Channel E2 (even)
19	RXE2+	Positive LVDS differential data input. Channel E2 (even)
20	RXEC-	Negative LVDS differential clock input. (even)
21	RXEC+	Positive LVDS differential clock input. (even)
22	RXE3-	Negative LVDS differential data input. Channel E3 (even)
23	RXE3+	Positive LVDS differential data input. Channel E3 (even)
24	GND	Ground
25	NC	Not connection, this pin should be open.
26	AGMODE	AGMODE should be tied to ground or open.
27	VCC	+5.0V power supply
28	VCC	+5.0V power supply
29	VCC	+5.0V power supply
30	VCC	+5.0V power supply

Note (1) Connector Part No.: 093G30-B0001A(STARCONN) or FI-X30SSL-HF(JAE) or EQUIVALENT.

Note (2) The first pixel is odd.

Note (3) Input signal of even and odd clock should be the same timing.

5.2 LVDS DATA MAPPING TABLE

LVDS Channel O0	LVDS output	D7	D6	D4	D3	D2	D1	D0
	Data order	OG0	OR5	OR4	OR3	OR2	OR1	OR0
LVDS Channel O1	LVDS output	D18	D15	D14	D13	D12	D9	D8
	Data order	OB1	OB0	OG5	OG4	OG3	OG2	OG1
LVDS Channel O2	LVDS output	D26	D25	D24	D22	D21	D20	D19
	Data order	DE	NA	NA	OB5	OB4	OB3	OB2
LVDS Channel O3	LVDS output	D23	D17	D16	D11	D10	D5	D27
	Data order	NA	OB7	OB6	OG7	OG6	OR7	OR6
LVDS Channel E0	LVDS output	D7	D6	D4	D3	D2	D1	D0
	Data order	EG0	ER5	ER4	ER3	ER2	ER1	ER0
LVDS Channel E1	LVDS output	D18	D15	D14	D13	D12	D9	D8
	Data order	EB1	EB0	EG5	EG4	EG3	EG2	EG1
LVDS Channel E2	LVDS output	D26	D25	D24	D22	D21	D20	D19
	Data order	DE	NA	NA	EB5	EB4	EB3	EB2
LVDS Channel E3	LVDS output	D23	D17	D16	D11	D10	D5	D27
	Data order	NA	EB7	EB6	EG7	EG6	ER7	ER6



Approval

5.3 BACKLIGHT UNIT

Pin	Symbol	Description	Remark
1	HV	High Voltage	Pink
2	LV	Low Voltage	White
1	HV	High Voltage	Blue
2	LV	Low Voltage	Black

Note (1) Connector Part No.: YEONHO 35001HS-02L or equivalent

Note (2) User's connector Part No.: YEONHO 35001WR-02L or equivalent

5.4 COLOR DATA INPUT ASSIGNMENT

The brightness of each primary color (red, green and blue) is based on the 8-bit gray scale data input for the color. The higher the binary input, the brighter the color. The table below provides the assignment of color versus data input.

Color		Data Signal																							
		Red								Green								Blue							
		R7	R6	R5	R4	R3	R2	R1	R0	G7	G6	G5	G4	G3	G2	G1	G0	B7	B6	B5	B4	B3	B2	B1	B0
Basic Colors	Black	0	0	0	0	0	0	0	0	0	0	0	0	0	0	0	0	0	0	0	0	0	0	0	0
	Red	1	1	1	1	1	1	1	1	0	0	0	0	0	0	0	0	0	0	0	0	0	0	0	0
	Green	0	0	0	0	0	0	0	0	1	1	1	1	1	1	1	1	0	0	0	0	0	0	0	0
	Blue	0	0	0	0	0	0	0	0	0	0	0	0	0	0	0	0	1	1	1	1	1	1	1	1
	Cyan	0	0	0	0	0	0	0	0	1	1	1	1	1	1	1	1	1	1	1	1	1	1	1	1
	Magenta	1	1	1	1	1	1	1	1	0	0	0	0	0	0	0	0	1	1	1	1	1	1	1	1
	Yellow	1	1	1	1	1	1	1	1	1	1	1	1	1	1	1	1	0	0	0	0	0	0	0	0
	White	1	1	1	1	1	1	1	1	1	1	1	1	1	1	1	1	1	1	1	1	1	1	1	1
Gray Scale Of Red	Red(0) / Dark	0	0	0	0	0	0	0	0	0	0	0	0	0	0	0	0	0	0	0	0	0	0	0	0
	Red(1)	0	0	0	0	0	0	0	1	0	0	0	0	0	0	0	0	0	0	0	0	0	0	0	0
	Red(2)	0	0	0	0	0	0	1	0	0	0	0	0	0	0	0	0	0	0	0	0	0	0	0	0
	⋮	⋮	⋮	⋮	⋮	⋮	⋮	⋮	⋮	⋮	⋮	⋮	⋮	⋮	⋮	⋮	⋮	⋮	⋮	⋮	⋮	⋮	⋮	⋮	⋮
	⋮	⋮	⋮	⋮	⋮	⋮	⋮	⋮	⋮	⋮	⋮	⋮	⋮	⋮	⋮	⋮	⋮	⋮	⋮	⋮	⋮	⋮	⋮	⋮	⋮
	Red(253)	1	1	1	1	1	1	0	1	0	0	0	0	0	0	0	0	0	0	0	0	0	0	0	0
	Red(254)	1	1	1	1	1	1	1	0	0	0	0	0	0	0	0	0	0	0	0	0	0	0	0	0
	Red(255)	1	1	1	1	1	1	1	1	0	0	0	0	0	0	0	0	0	0	0	0	0	0	0	0
Gray Scale Of Green	Green(0) / Dark	0	0	0	0	0	0	0	0	0	0	0	0	0	0	0	0	0	0	0	0	0	0	0	0
	Green(1)	0	0	0	0	0	0	0	0	0	0	0	0	0	0	0	1	0	0	0	0	0	0	0	0
	Green(2)	0	0	0	0	0	0	0	0	0	0	0	0	0	0	1	0	0	0	0	0	0	0	0	0
	⋮	⋮	⋮	⋮	⋮	⋮	⋮	⋮	⋮	⋮	⋮	⋮	⋮	⋮	⋮	⋮	⋮	⋮	⋮	⋮	⋮	⋮	⋮	⋮	⋮
	⋮	⋮	⋮	⋮	⋮	⋮	⋮	⋮	⋮	⋮	⋮	⋮	⋮	⋮	⋮	⋮	⋮	⋮	⋮	⋮	⋮	⋮	⋮	⋮	⋮
	Green(253)	0	0	0	0	0	0	0	0	1	1	1	1	1	1	0	1	0	0	0	0	0	0	0	0
	Green(254)	0	0	0	0	0	0	0	0	1	1	1	1	1	1	1	0	0	0	0	0	0	0	0	0
	Green(255)	0	0	0	0	0	0	0	0	1	1	1	1	1	1	1	1	0	0	0	0	0	0	0	0
Gray Scale Of Blue	Blue(0) / Dark	0	0	0	0	0	0	0	0	0	0	0	0	0	0	0	0	0	0	0	0	0	0	0	0
	Blue(1)	0	0	0	0	0	0	0	0	0	0	0	0	0	0	0	0	0	0	0	0	0	0	0	1
	Blue(2)	0	0	0	0	0	0	0	0	0	0	0	0	0	0	0	0	0	0	0	0	0	0	1	0
	⋮	⋮	⋮	⋮	⋮	⋮	⋮	⋮	⋮	⋮	⋮	⋮	⋮	⋮	⋮	⋮	⋮	⋮	⋮	⋮	⋮	⋮	⋮	⋮	⋮
	⋮	⋮	⋮	⋮	⋮	⋮	⋮	⋮	⋮	⋮	⋮	⋮	⋮	⋮	⋮	⋮	⋮	⋮	⋮	⋮	⋮	⋮	⋮	⋮	⋮
	Blue(253)	0	0	0	0	0	0	0	0	0	0	0	0	0	0	0	0	1	1	1	1	1	1	0	1
	Blue(254)	0	0	0	0	0	0	0	0	0	0	0	0	0	0	0	0	1	1	1	1	1	1	1	0
	Blue(255)	0	0	0	0	0	0	0	0	0	0	0	0	0	0	0	0	1	1	1	1	1	1	1	1

Note (1) 0: Low Level Voltage, 1: High Level Voltage

6. INTERFACE TIMING

6.1 INPUT SIGNAL TIMING SPECIFICATIONS

The input signal timing specifications are shown as the following table and timing diagram.

Signal	Item	Symbol	Min.	Typ.	Max.	Unit	Note
LVDS Clock	Frequency	Fc	57.6	77	83	MHz	-
	Period	Tc	12.05	13	17.36	ns	-
	High Time	Tch	-	4/7	-	Tc	-
	Low Time	Tcl	-	3/7	-	Tc	-
LVDS Data	Setup Time	Tlvs	600	-	-	ps	-
	Hold Time	Tlvh	600	-	-	ps	-
Vertical Active Display Term	Frame Rate	Fr	50	60	65	Hz	Tv=Tvd+Tvb
	Total	Tv	1210	1235	1350	Th	-
	Display	Tvd	1200	1200	1200	Th	-
	Blank	Tvb	Tv-Tvd	35	Tv-Tvd	Th	-
Horizontal Active Display Term	Total	Th	1000	1040	1114	Tc	Th=Thd+Thb
	Display	Thd	960	960	960	Tc	-
	Blank	Thb	Th-Thd	80	Th-Thd	Tc	-

6.2 POWER ON/OFF SEQUENCE

To prevent a latch-up or DC operation of LCD module, the power on/off sequence should follow the conditions shown in the following diagram.

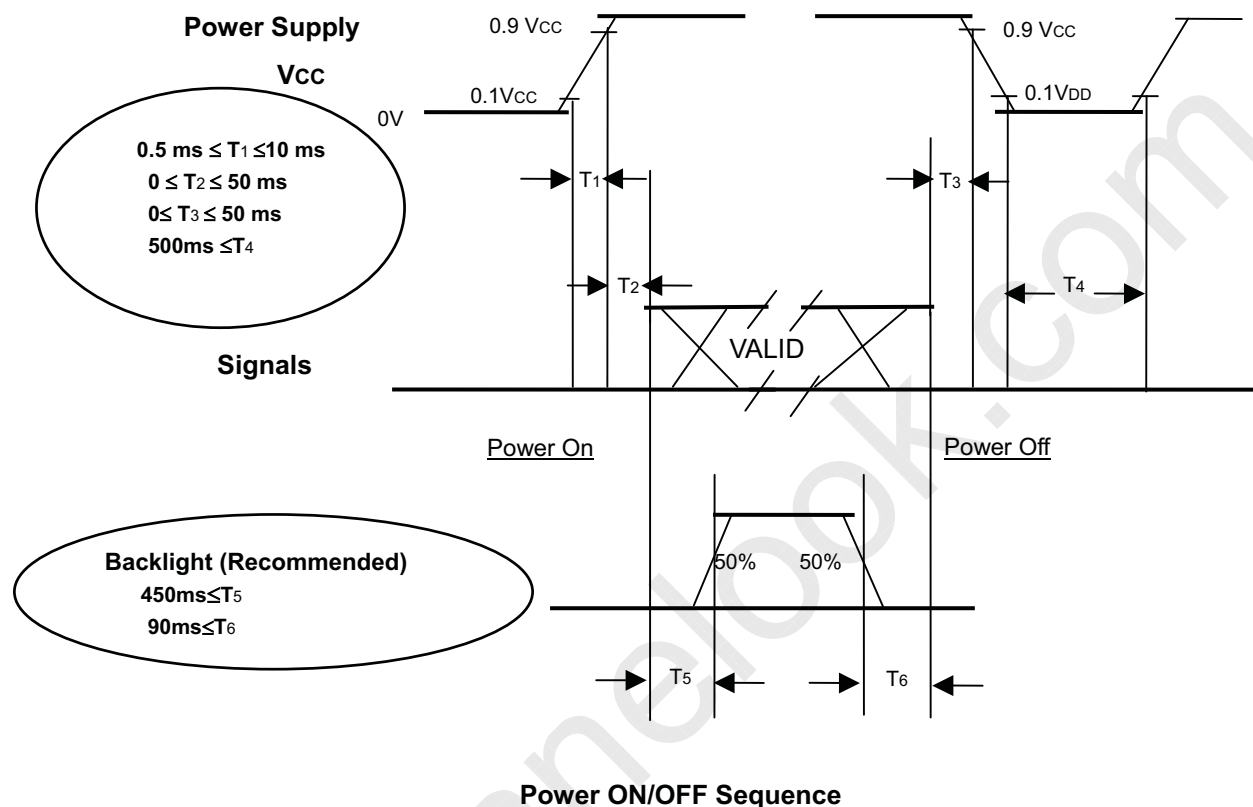

Note.

- (1) The supply voltage of the external system for the module input should be the same as the definition of Vcc.
- (2) Please apply the lamp voltage within the LCD operation range. When the backlight turns on before the LCD operation of the LCD turns off, the display may, instantly, function abnormally.
- (3) In case of vcc = off level, please keep the level of input signals on the low or keep a high impedance.
- (4) T4 should be measured after the module has been fully discharged between power on/off periods.
- (5) Interface signal shall not be kept at high impedance when the power is on.

7. OPTICAL CHARACTERISTICS

7.1 TEST CONDITIONS

Item	Symbol	Value	Unit
Ambient Temperature	Ta	25±2	°C
Ambient Humidity	Ha	50±10	%RH
Supply Voltage	V _{CC}	5.0	V
Input Signal	According to typical value in "3. ELECTRICAL CHARACTERISTICS"		
Inverter Current	I _L	7.0	mA
Inverter Driving Frequency	F _L	55	KHz
Inverter	Darfon VK.13165.101		

7.2 OPTICAL SPECIFICATIONS

The relative measurement methods of optical characteristics are shown in 7.2. The following items should be measured under the test conditions described in 7.1 and stable environment shown in Note (5).

Item	Symbol	Condition	Min.	Typ.	Max.	Unit	Note		
Color Chromaticity (CIE 1931)	Red	$\theta_x=0^\circ, \theta_y=0^\circ$ CS-1000T R=G=B=255 Grayscale	Typ - 0.03	0.649	Typ + 0.03		(1), (5)		
				0.335					
	Green			0.283					
				0.605					
	Blue			0.151					
				0.073					
	White			0.313					
				0.329					
Center Luminance of White	L _C		250	300	---	cd/m ²	(4), (5)		
Contrast Ratio	CR		700	1000	---	-	(2), (5)		
Response Time	T _R	$\theta_x=0^\circ, \theta_y=0^\circ$	---	1.3	2.2	ms	(3)		
	T _F		---	3.7	5.8	ms			
White Variation	δW	$\theta_x=0^\circ, \theta_y=0^\circ$ USB2000	---	---	1.33	-	(5), (6)		
Viewing Angle	Horizontal	CR>10 USB2000		75	85	---	Deg.	(1), (5)	
				75	85	---			
	Vertical			70	80	---			
				70	80	---			
	Horizontal			CR>5 USB2000	80	89			---
					80	89			---
	Vertical				80	89			---
					80	89			---

Note (1) Definition of Viewing Angle (θ_x, θ_y):

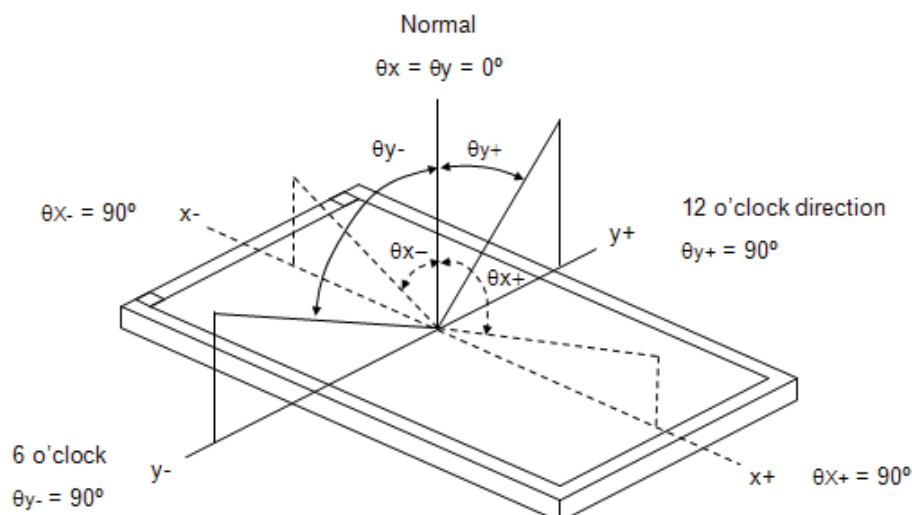

Note (2) Definition of Contrast Ratio (CR):

The contrast ratio can be calculated by the following expression.

$$\text{Contrast Ratio (CR)} = L_{255} / L_0$$

L255: Luminance of gray level 255

L 0: Luminance of gray level 0

$$\text{CR} = \text{CR} (5)$$

CR (X) is corresponding to the Contrast Ratio of the point X at Figure in Note (6).

Note (3) Definition of Response Time (T_R , T_F):

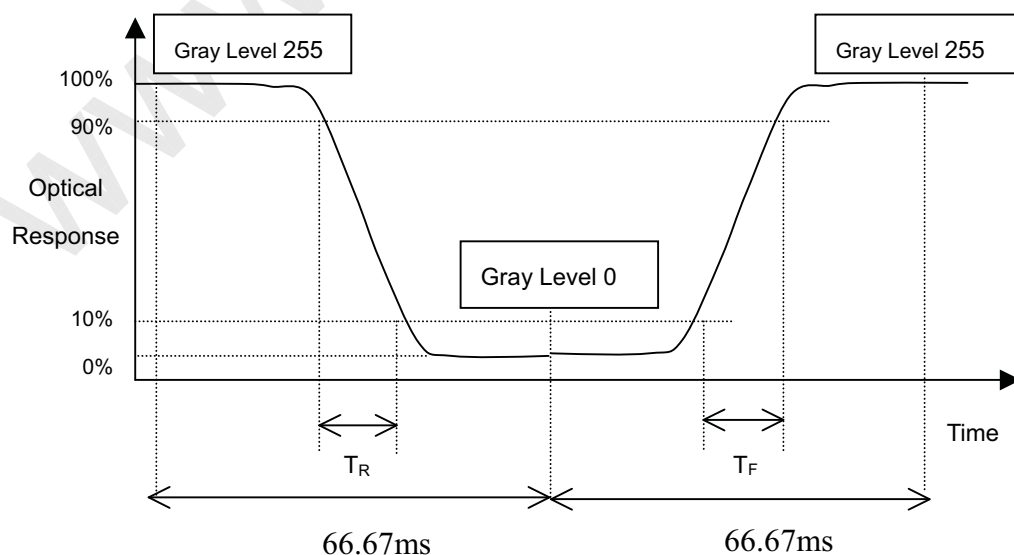

Note (4) Definition of Luminance of White (L_C):

Measure the luminance of gray level 255 at center point

$$L_C = L(5)$$

$L(x)$ is corresponding to the luminance of the point X at Figure in Note (6).

Note (5) Measurement Setup:

The LCD module should be stabilized at given temperature for 40 minutes to avoid abrupt temperature change during measuring. In order to stabilize the luminance, the measurement should be executed after lighting Backlight for 40 minutes in a windless room.

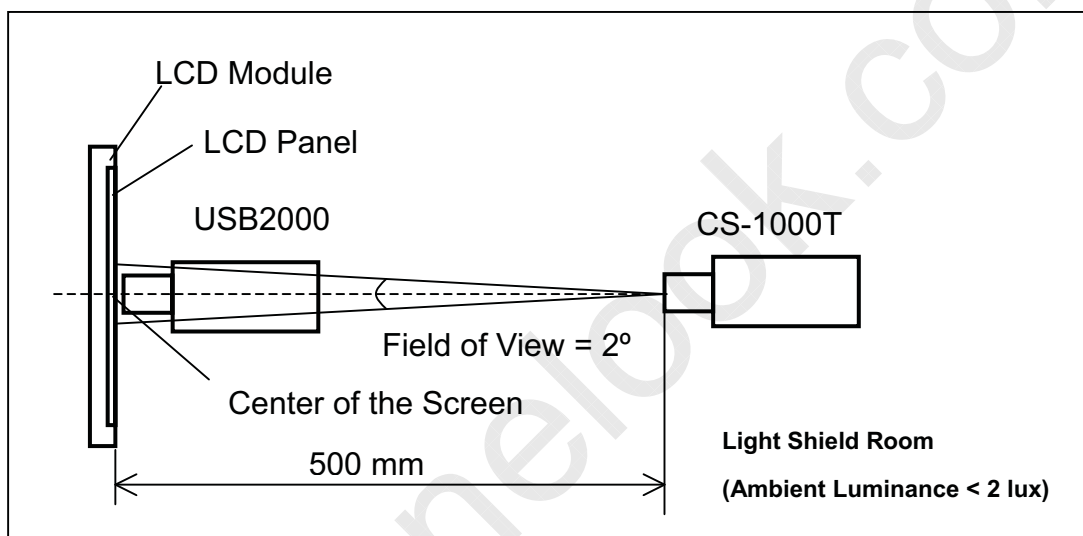

Note (6) Definition of White Variation (δW):

Measure the luminance of gray level 255 at 9 points

$$\delta W = \text{Maximum} [L(1) \sim L(9)] / \text{Minimum} [L(1) \sim L(9)]$$

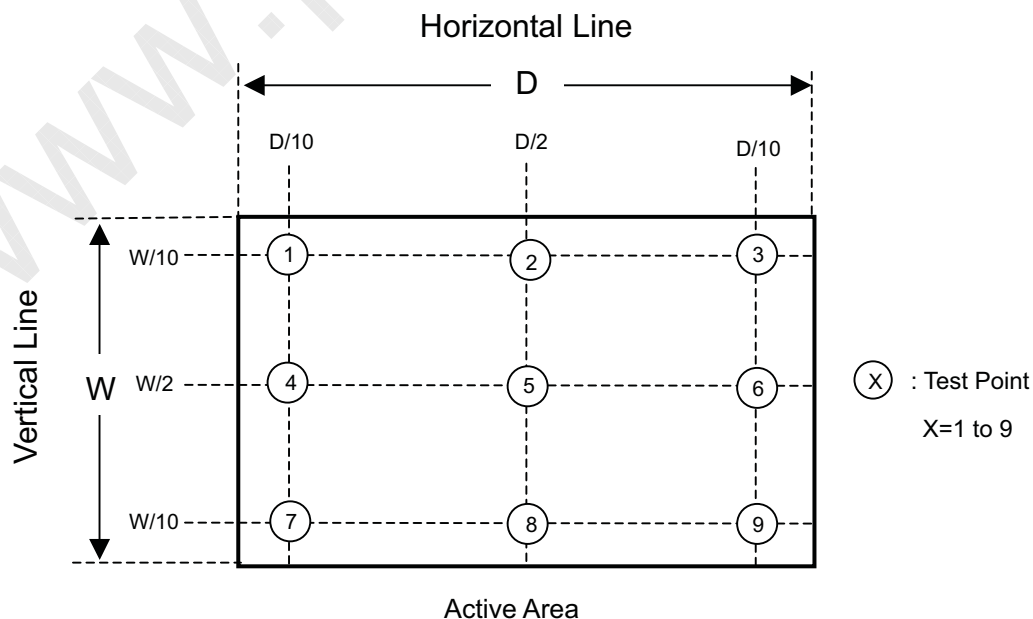

8. PACKAGING

8.1 PACKING SPECIFICATIONS

- (1) 6 LCD modules / 1 Box
- (2) Box dimensions: 595(L) X 330 (W) X 440 (H) mm
- (3) Weight: 17.48 Kg (6 modules per box)

8.2 PACKING METHOD

- (1) Carton Packing should have no failure in the following reliability test items.

Test Item	Test Conditions	Note
Vibration	ISTA STANDARD Random, Frequency Range: 1 – 200 Hz Top & Bottom: 30 minutes (+Z), 10 min (-Z), Right & Left: 10 minutes (X) Back & Forth 10 minutes (Y)	Non Operation
Dropping Test	1 Corner, 3 Edges, 6 Faces, 60cm	Non Operation

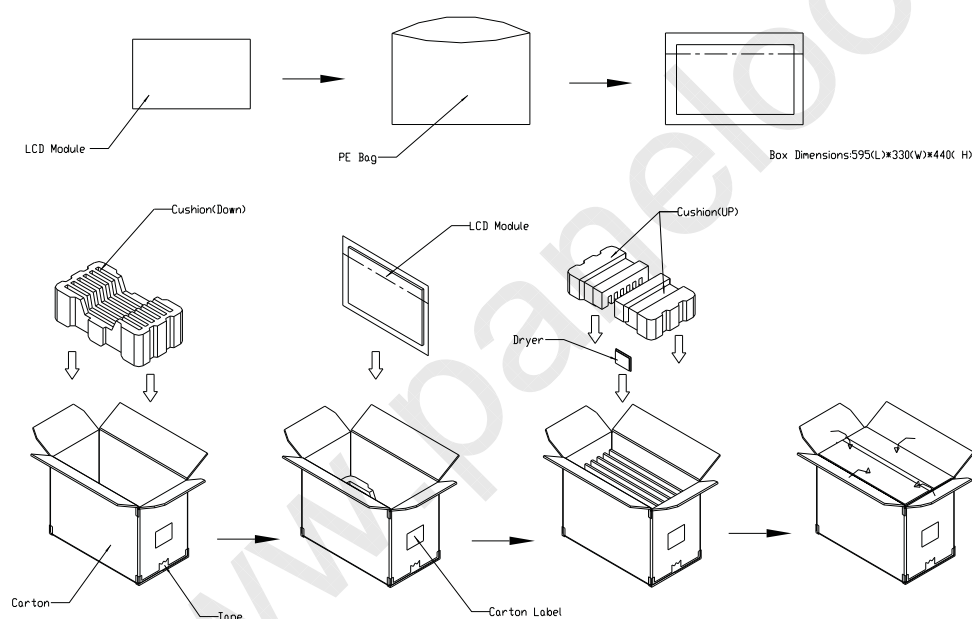

Figure. 8-1 Packing method

For ocean shipping

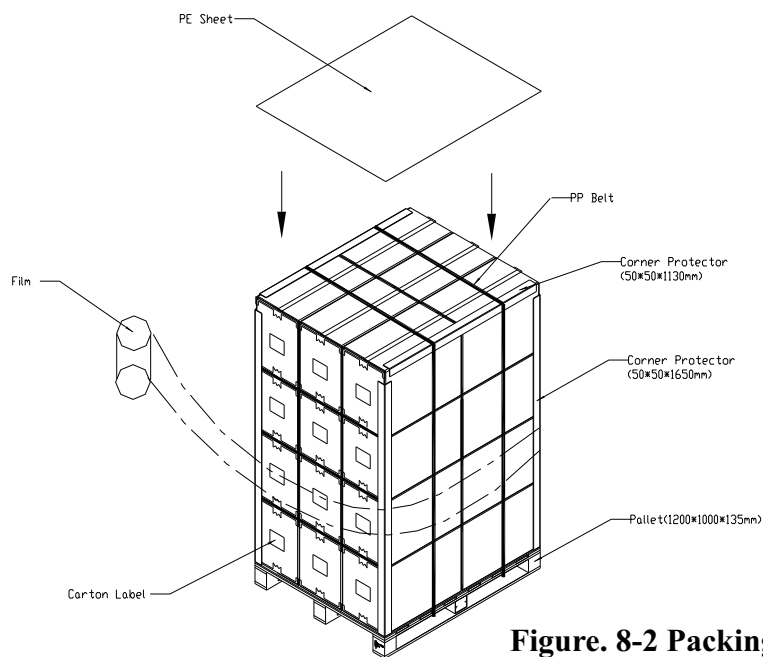

Figure. 8-2 Packing method

For air transport

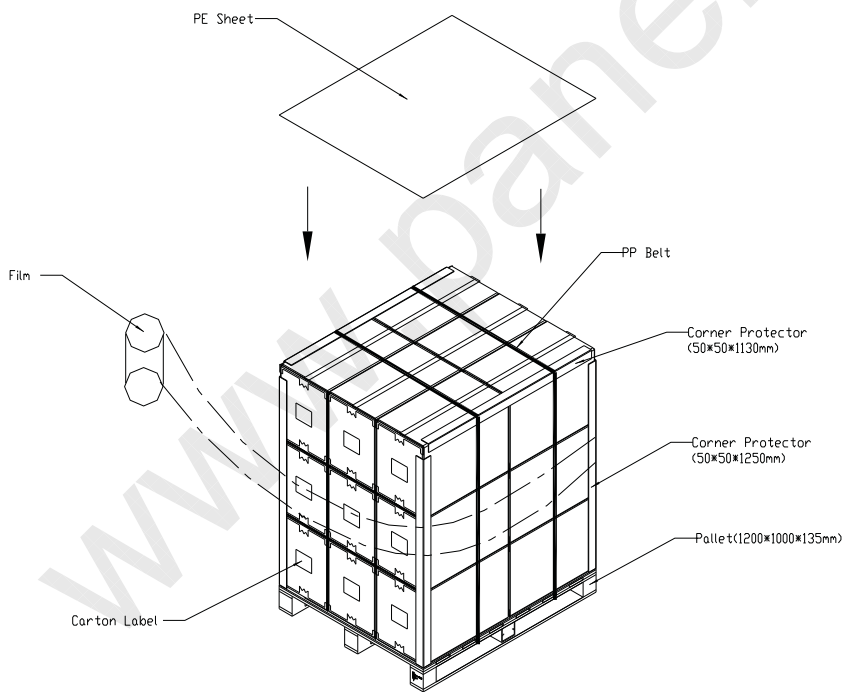

Figure. 8-3 Packing method

9. DEFINITION OF LABELS

9.1 CMO MODULE LABEL

The barcode nameplate is pasted on each module as illustration, and its definitions are as following explanation.



- (a) Model Name: M220J1-L01
- (b) Revision: Rev. XX, for example: A0, A1... B1, B2... or C1, C2...etc.
- (c) CMO barcode definition:

Serial ID: XX-XX-X-XX-YMD-L-NNNN

Code	Meaning	Description
XX	CMO internal use	-
XX	Revision	Cover all the change
X	CMO internal use	-
XX	CMO internal use	-
YMD	Year, month, day	Year: 2001=1, 2002=2, 2003=3, 2004=4... Month: 1~12=1, 2, 3, ~, 9, A, B, C Day: 1~31=1, 2, 3, ~, 9, A, B, C, ~, W, X, Y, exclude I, O, and U.
L	Product line #	Line 1=1, Line 2=2, Line 3=3, ...
NNNN	Serial number	Manufacturing sequence of product

- (d) Customer's barcode definition:

Serial ID: CM-22J11-X-X-X-XX-L-XX-L-YMD-NNNN

Code	Meaning	Description
CM	Supplier code	CMO=CM
22J11	Model number	M220J1-L01=22J11
X	Revision code	ZBD, C1=A, C2=B, Non ZBD, C1=1, C2=2,
X	Source driver IC code	Century=1, CLL=2, Demos=3, Epson=4, Fujitsu=5, Himax=6, Hitachi=7, Hynix=8, LDI=9, Matsushita=A, NEC=B, Novatec=C, OKI=D, Philips=E, Renasas=F, Samsung=G, Sanyo=H, Sharp=I, TI=J, Topro=K, Toshiba=L, Windbond=M
X	Gate driver IC code	
XX	Cell location	Tainan, Taiwan=TN
L	Cell line #	1~12=0~C
XX	Module location	Tainan, Taiwan=TN; Ningbo China=NP
L	Module line #	1~12=0~C
YMD	Year, month, day	Year: 2001=1, 2002=2, 2003=3, 2004=4... Month: 1~12=1, 2, 3, ~, 9, A, B, C Day: 1~31=1, 2, 3, ~, 9, A, B, C, ~, T, U, V
NNNN	Serial number	By LCD supplier

10. PRECAUTIONS

10.1 ASSEMBLY AND HANDLING PRECAUTIONS

- (1) Do not apply rough force such as bending or twisting to the module during assembly.
- (2) To assemble or install module into user's system can be only in clean working areas. The dust and oil may cause electrical short or worsen the polarizer.
- (3) It's not permitted to have pressure or impulse on the module because the LCD panel and Backlight will be damaged.
- (4) Always follow the correct power sequence when LCD module is connecting and operating. This can prevent damage to the CMOS LSI chips during latch-up.
- (5) Do not pull the I/F connector in or out while the module is operating.
- (6) Do not disassemble the module.
- (7) Use a soft dry cloth without chemicals for cleaning, because the surface of polarizer is very soft and easily scratched.
- (8) It is dangerous that moisture come into or contacted the LCD module, because moisture may damage LCD module when it is operating.
- (9) High temperature or humidity may reduce the performance of module. Please store LCD module within the specified storage conditions.
- (10) When ambient temperature is lower than 10°C may reduce the display quality. For example, the response time will become slowly, and the starting voltage of CCFL will be higher than room temperature.

10.2 SAFETY PRECAUTIONS

- (1) The startup voltage of Backlight is approximately 1000 Volts. It may cause electrical shock while assembling with inverter. Do not disassemble the module or insert anything into the Backlight unit.
- (2) If the liquid crystal material leaks from the panel, it should be kept away from the eyes or mouth. In case of contact with hands, skin or clothes, it has to be washed away thoroughly with soap.
- (3) After the module's end of life, it is not harmful in case of normal operation and storage.

10.3 SAFETY STANDARDS

The LCD module should be certified with safety regulations as follows:

- (1) UL60950-1 or updated standard.
- (2) IEC60950-1 or updated standard.

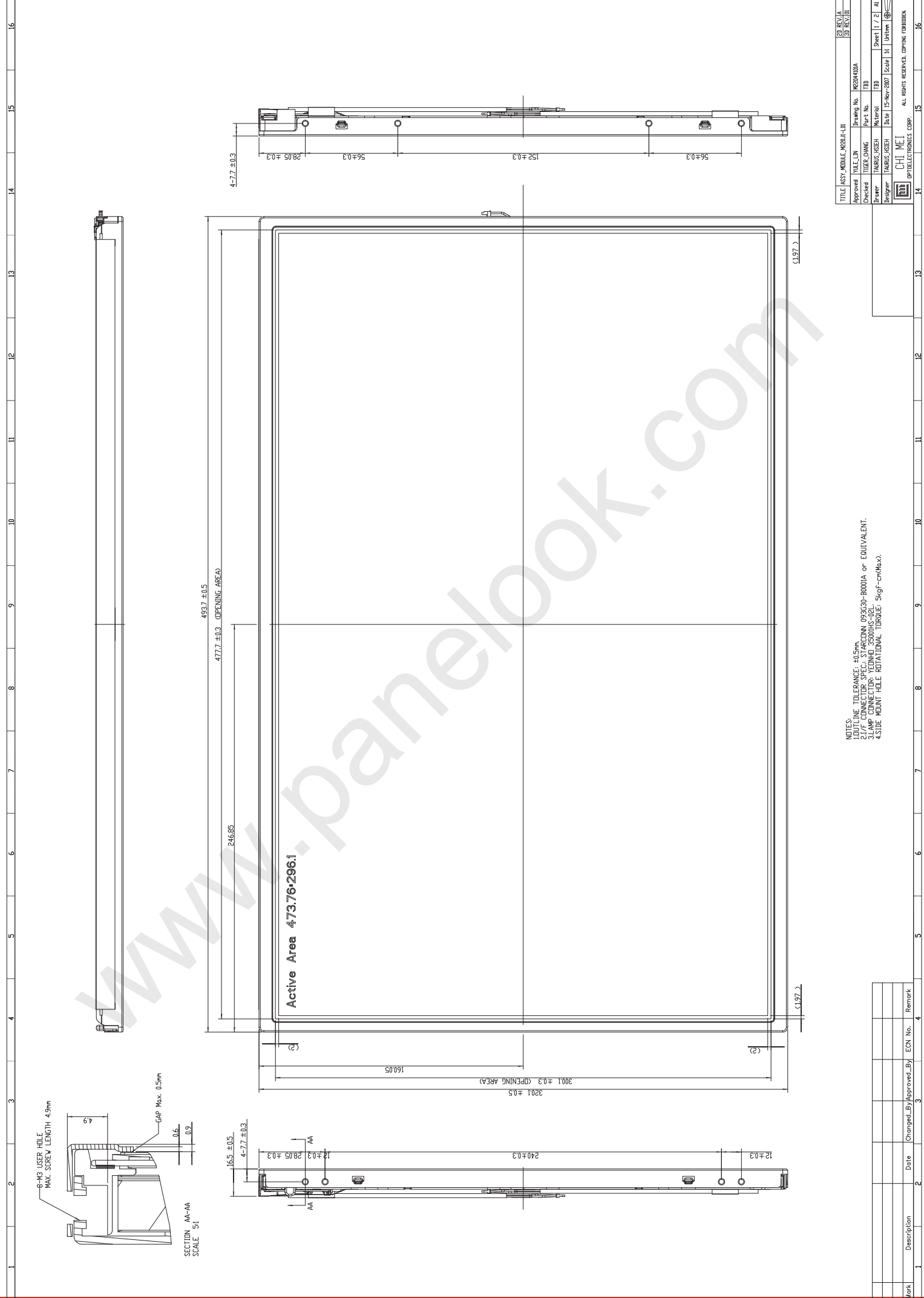

NOTES:
 1. OUTLINE TOLERANCE: ±0.5mm.
 2. I/F CONNECTOR SPEC.: STARCOM: 093C30-B000A or EQUIVALENT.
 3. I/F CONNECTOR MOUNTING: 4-SIDE MOUNT.
 4. SIDE MOUNT: HOLE ROTATIONAL TOLERANCE: 5kgF-cm(Max).

TITLE	ASSEMBLY	MIDDLE	M250J-L10	ED. REV.1/A	3D. REV.1/B
Approved	YALE LIN	Drawing No.	HW30400A		
Checked	TIGER CHANG	Part No.	TBD		
Drawn	TAURUS JSEH	Material	TBD	Sheet 1 / 2	AL
Designer	TAURUS JSEH	Date	15-Nov-2007	Scale	1:1

Mark	Description	Date	Changed By	Approved By	ECN No.	Remark

CHI MET
 OPTOELECTRONICS CORP.
 ALL RIGHTS RESERVED. COPYING FORBIDDEN.

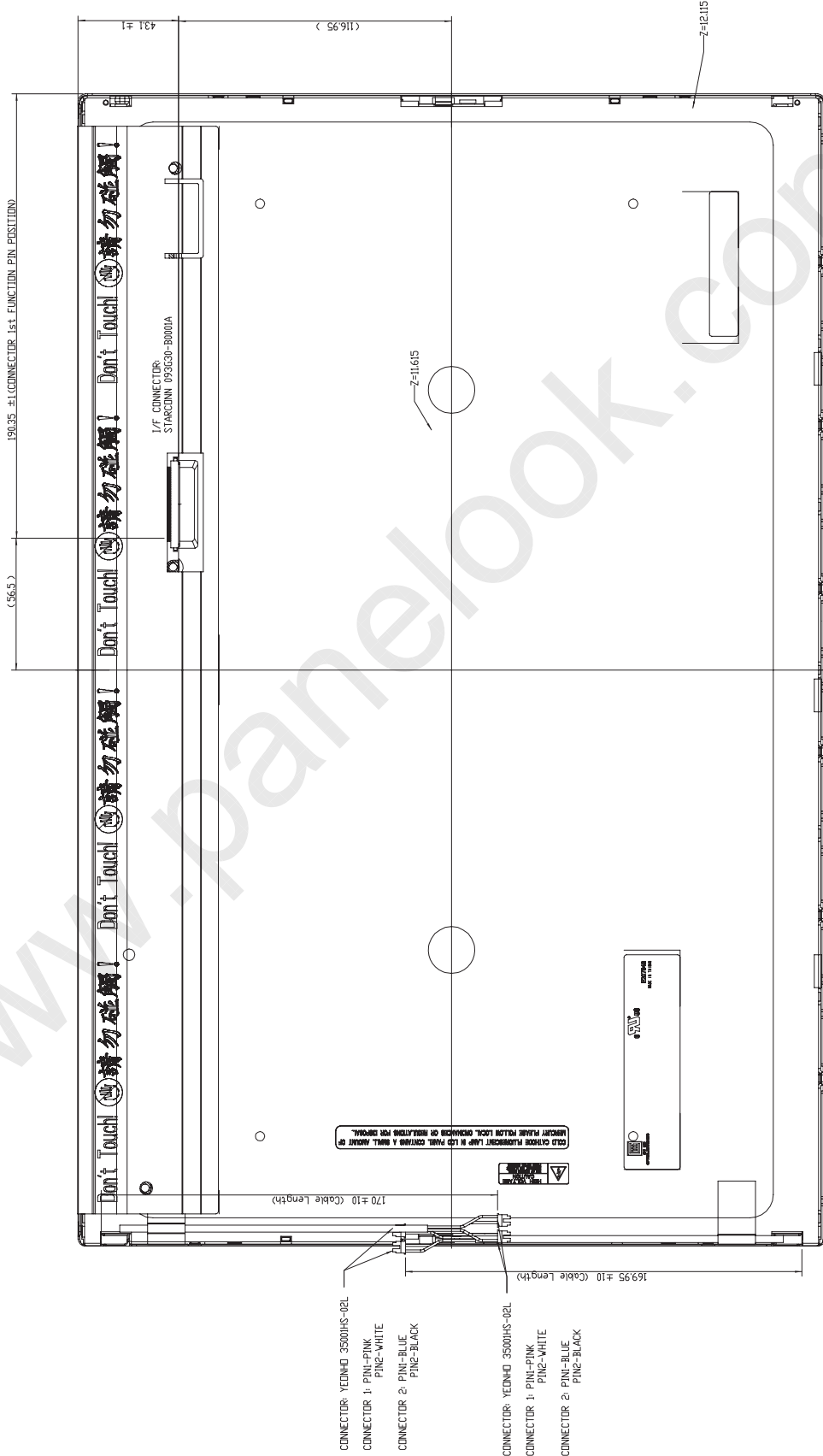

NOTES:
 1. OUTLINE TOLERANCE: ±0.5mm
 2. 1/4 CONNECTOR SPEC: STARCODN 093G30-80001A or EQUIVALENT.
 3. LAMP CONNECTOR: YEDNHD 3500HS-02L.
 4. SIDE MOUNT HOLE ROTATIONAL TOLERANCE: 5kgf-cm(Max).

TITLE	ASST MIDDLE M250-L101	2D REV.1/A
Approved	YALE LIN	3D REV.1/B
Checked	TIGER CHANG	Part No. W23M400A
Designer	TAURUS JOSEH	Part No. TBD
	TAURUS JOSEH	Material TBD
	TAURUS JOSEH	Date 15-Nov-2007
		Scale 1:1
		Sheet 2 / 2
		Of 2
		Unit
		Unit

CHI MET
 OPTOELECTRONICS CORP.
 ALL RIGHTS RESERVED. COPYING FORBIDDEN.

Mark	Description	Date	Changed By	Approved By	ECN No.	Remark