

Doc. Number :

- Tentative Specification
- Preliminary Specification
- Approval Specification

MODEL NO.: M236HHF
SUFFIX: L11

Customer:
APPROVED BY
SIGNATURE
Name / Title _____

Note

Product Version C1

Please return 1 copy for your confirmation with your signature and comments.

Approved By	Checked By	Prepared By
吳柏勳	梁永祥	林秋森

CONTENTS

1. GENERAL DESCRIPTION	5
1.1 OVERVIEW	5
1.2 GENERAL SPECIFICATIONS	5
2. MECHANICAL SPECIFICATIONS	5
3. ABSOLUTE MAXIMUM RATINGS	5
3.1 ABSOLUTE RATINGS OF ENVIRONMENT	5
3.2 ELECTRICAL ABSOLUTE RATINGS	6
3.2.1 TFT LCD MODULE	6
3.2.2 BACKLIGHT UNIT	6
4. ELECTRICAL SPECIFICATIONS	7
4.1 FUNCTION BLOCK DIAGRAM	7
4.2. INTERFACE CONNECTIONS	7
4.2.1 51PIN CONNECTOR PIN ASSIGNMENT	7
4.2.2 41PIN CONNECTOR PIN ASSIGNMENT	8
4.2.3 10PIN CONNECTOR PIN ASSIGNMENT	9
4.3 ELECTRICAL CHARACTERISTICS	12
4.3.1 LCD ELETRONICS SPECIFICATION	12
4.3.2 BACKLIGHT UNIT	14
4.3.3 LIGHTBAR Connector Pin Assignment	14
4.4 LVDS INPUT SIGNAL SPECIFICATIONS	15
4.4.1 LVDS DATA MAPPING TABLE	15
4.4.2 COLOR DATA INPUT ASSIGNMENT	16
4.5 DISPLAY TIMING SPECIFICATIONS	17
4.5.1 TIMING SPEC FOR FRAME RATE ($F_{r5} = 100\text{Hz}$)	17
4.5.2 TIMING SPEC FOR FRAME RATE ($F_{r6} = 120\text{Hz}$)	17
4.6 POWER ON/OFF SEQUENCE	21
4.6.1 POWER ON/OFF SEQUENCE($T_a = 25 \pm 2 \text{ }^\circ\text{C}$)	21
4.6.2 2D to 3D SIGNAL SEQUENCE WITHOUT VCC TURN OFF AND TURN ON	22
5. OPTICAL CHARACTERISTICS	23
5.1 TEST CONDITIONS	23
5.2 OPTICAL SPECIFICATIONS	23
6. RELIABILITY TEST ITEM	28
7. PACKING	29
7.1 PACKING SPECIFICATIONS	29
7.2 PACKING METHOD	29

7.3 PALLET	30
8. CMI MODULE LABEL	31
9. PRECAUTIONS	32
9.1 ASSEMBLY AND HANDLING PRECAUTIONS	32
9.2 STORAGE PRECAUTIONS	32
9.3 OPERATION PRECAUTIONS	32
9.4 SAFETY PRECAUTIONS	33
9.5 SAFETY STANDARDS	33
9.6 OTHER	33
Appendix. OUTLINE DRAWING	33

REVISION HISTORY

Version	Date	Page	Description
2.0	Mar,02, 2011	All	Spec Ver.2.0 was first issued.

1. GENERAL DESCRIPTION

1.1 OVERVIEW

The M236HHF-L11 model is a 23.6" wide TFT-LCD module with a WLED Backlight Unit and 4ch-LVDS interface. This module supports 1920 x 1080 Full HD mode and displays up to 16.7 million colors. The converter module for the Backlight Unit is not built in.

1.2 GENERAL SPECIFICATIONS

Item	Specification	Unit	Note
Screen Size	23.6" real diagonal	-	-
Driver Element	a-si TFT active matrix	-	-
Pixel Number	1920 x R.G.B. x 1080	pixel	-
Pixel Pitch	0.2715 (H) x 0.2715 (V)	mm	-
Pixel Arrangement	RGB vertical stripe	-	-
Display Colors	16.7M	color	-
Transmissive Mode	Normally white	-	-
Surface Treatment	AG type, 3H hard coating, Haze 25	-	-
Luminance, White	300	Cd/m2	-
Color Gamut	72% of NTSC(Typ.)	-	-
TCO	TCO 5.0 compliance	-	-
Power Consumption	Total 20.1 W (Typ.) @ cell 7.8 W (Typ.), BL 12.3 W (Typ.)		(1)

Note (1) The specified power consumption : Total= cell (reference 4.3.1)+BL (reference 4.3.3)

2. MECHANICAL SPECIFICATIONS

Item	Min.	Typ.	Max.	Unit	Note	
Module Size	Horizontal (H)	544.3	544.8	545.3	mm	(1)
	Vertical (V)	320.0	320.5	321.0	mm	
	Thickness (T)	14.1	14.6	15.1	mm	
Bezel Area	Horizontal	524.92	525.22	525.52	mm	-
	Vertical	296.92	297.22	297.52	mm	-
Active Area	Horizontal	-	521.28	-	mm	-
	Vertical	-	293.22	-	mm	-
Weight	-	2550	2650	g	-	

Note (1) Please refer to the attached drawings for more information of front and back outline dimensions.

3. ABSOLUTE MAXIMUM RATINGS

3.1 ABSOLUTE RATINGS OF ENVIRONMENT

Item	Symbol	Value		Unit	Note
		Min.	Max.		
Storage Temperature	TST	-20	60	°C	(1)
Operating Ambient Temperature	TOP	0	50	°C	(1), (2)

Note (1)

(a) 90 %RH Max. (Ta <= 40 °C).

(b) Wet-bulb temperature should be 39 °C Max. (Ta > 40 °C).

(c) No condensation.

Note (2) The temperature of panel surface should be 0 °C min. and 60 °C max.

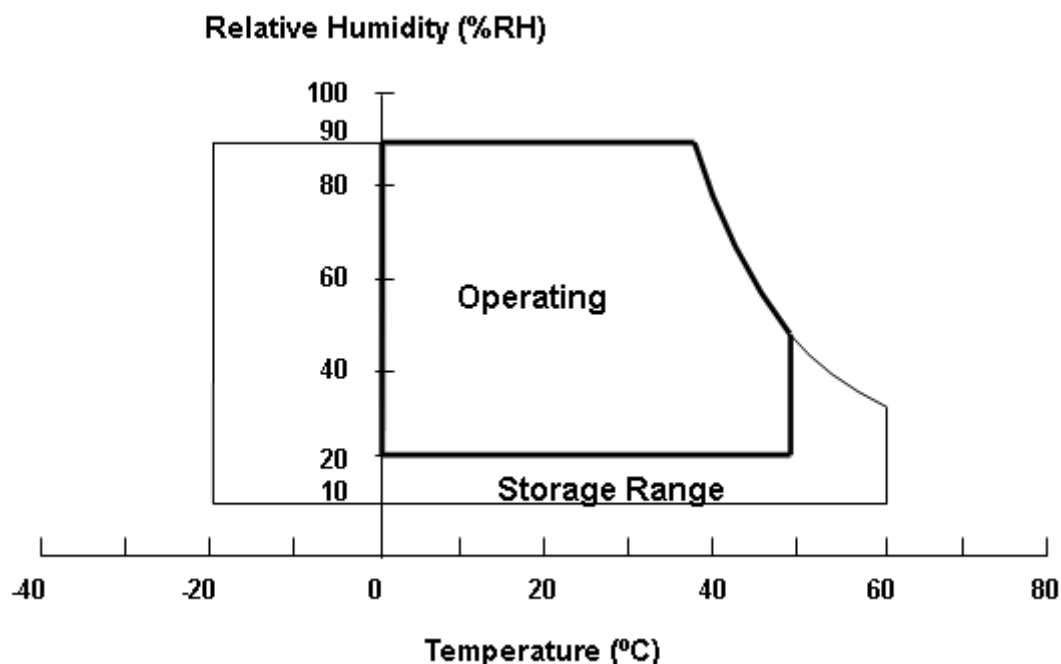

3.2 ELECTRICAL ABSOLUTE RATINGS

3.2.1 TFT LCD MODULE

Item	Symbol	Value		Unit	Note
		Min.	Max.		
Power Supply Voltage	V _{CCI}	-0.3	12.6	V	(1)
Logic Input Voltage	V _{IN}	-0.3	3.6	V	

3.2.2 BACKLIGHT UNIT

Item	Symbol	Value			Unit	Note
		Min.	Typ	Max.		
LED Forward Current Per Input Pin	I _F	---	40	56	mA	(1), (2) Duty=100%
LED Reverse Voltage Per Input Pin	V _R	---	---	60	V	
LED Pulse Forward Current Per Input Pin	I _P	---	---	160	mA	(1), (2) Pulse Width ≤ 10msec. and Duty ≤ 10%

Note (1) Permanent damage to the device may occur if maximum values are exceeded. Function operation should be restricted to the conditions described under Normal Operating Conditions.

Note (2) Specified values are for input pin of LED light bar at Ta=25±2 °C (Refer to 4.3.3 and 4.3.4 for further information).

4. ELECTRICAL SPECIFICATIONS

4.1 FUNCTION BLOCK DIAGRAM

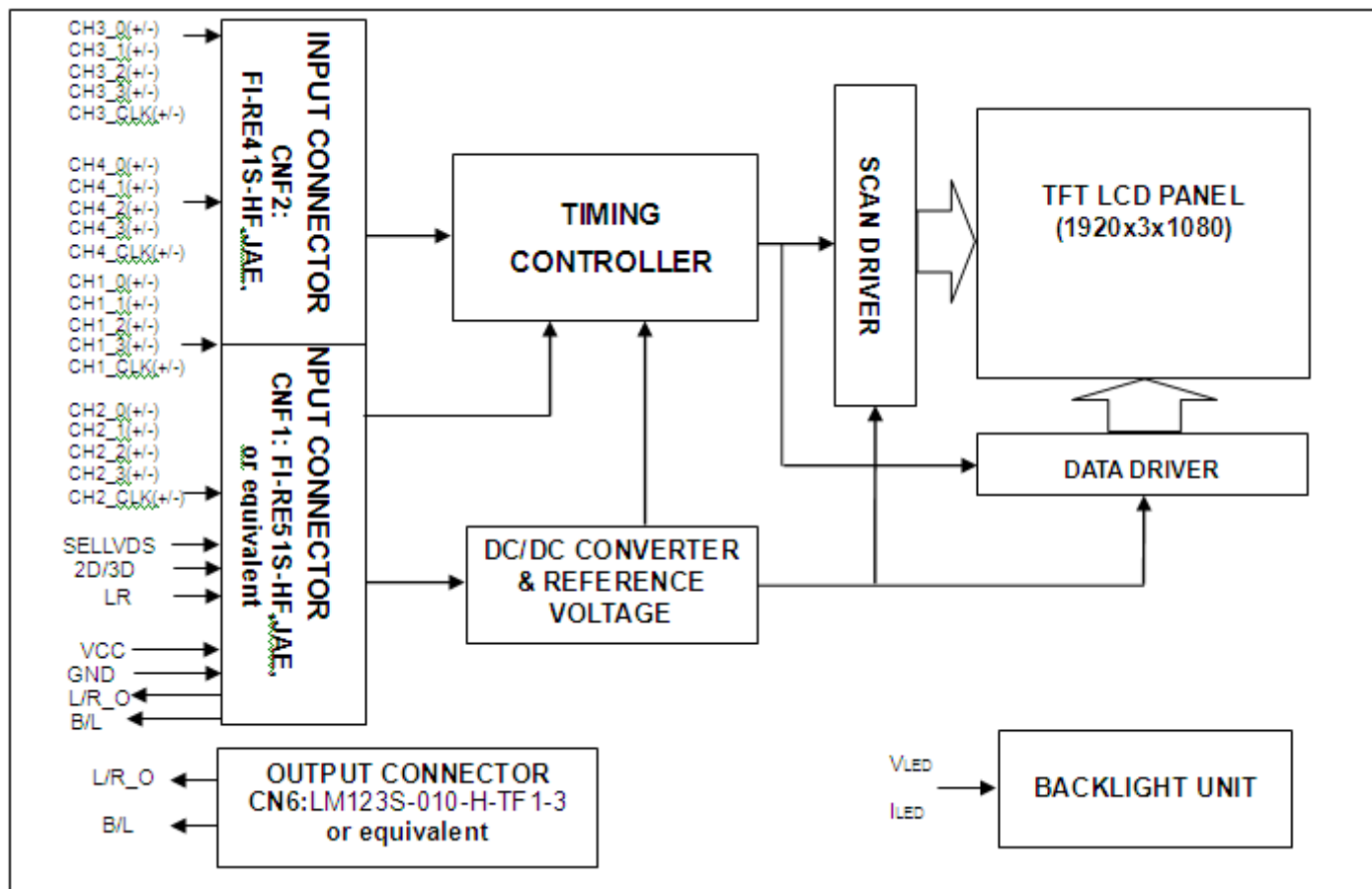

4.2. INTERFACE CONNECTIONS

4.2.1 51PIN CONNECTOR PIN ASSIGNMENT

Connector Part No.: FI-RE51S-HF(JAE) or equivalent.

Pin	Name	Description	Note
1	N.C.	No Connection	(1)
2	N.C.	No Connection	
3	N.C.	No Connection	
4	N.C.	No Connection	
5	L/R_O	Output signal for Left Right Glasses control	(7)
6	B/L	Output signal for backlight on/off control signal , H: B/L off, L: B/L on (3D only)	H: +3.3V L: 0V
7	SELLVDS	LVDS Data Format Selection	(2)(6)
8	N.C.	No Connection	(1)
9	N.C.	No Connection	
10	N.C.	No Connection	
11	GND	Ground	
12	CH1[0]-	First pixel Negative LVDS differential data input. Pair 0	
13	CH1[0]+	First pixel Positive LVDS differential data input. Pair 0	
14	CH1[1]-	First pixel Negative LVDS differential data input. Pair 1	
15	CH1[1]+	First pixel Positive LVDS differential data input. Pair 1	
16	CH1[2]-	First pixel Negative LVDS differential data input. Pair 2	
17	CH1[2]+	First pixel Positive LVDS differential data input. Pair 2	

18	GND	Ground	
19	CH1CLK-	First pixel Negative LVDS differential clock input.	
20	CH1CLK+	First pixel Positive LVDS differential clock input.	
21	GND	Ground	
22	CH1[3]-	First pixel Negative LVDS differential data input. Pair 3	
23	CH1[3]+	First pixel Positive LVDS differential data input. Pair 3	
24	N.C.	No Connection	
25	N.C.	No Connection	
26	2D/3D	Input signal for 2D/3D Mode Selection	(3)(5)
27	LR	Input signal for Left Right eye frame synchronous	(4)(5)
28	CH2[0]-	Second pixel Negative LVDS differential data input. Pair 0	
29	CH2[0]+	Second pixel Positive LVDS differential data input. Pair 0	
30	CH2[1]-	Second pixel Negative LVDS differential data input. Pair 1	
31	CH2[1]+	Second pixel Positive LVDS differential data input. Pair 1	
32	CH2[2]-	Second pixel Negative LVDS differential data input. Pair 2	
33	CH2[2]+	Second pixel Positive LVDS differential data input. Pair 2	
34	GND	Ground	
35	CH2CLK-	Second pixel Negative LVDS differential clock input.	
36	CH2CLK+	Second pixel Positive LVDS differential clock input.	
37	GND	Ground	
38	CH2[3]-	Second pixel Negative LVDS differential data input. Pair 3	
39	CH2[3]+	Second pixel Positive LVDS differential data input. Pair 3	
40	N.C.	No Connection	
41	N.C.	No Connection	
42	NC	No Connection	
43	N.C.	No Connection	(1)
44	GND	Ground	
45	GND	Ground	
46	GND	Ground	
47	N.C.	No Connection	(1)
48	VCC	+12V power supply	
49	VCC	+12V power supply	
50	VCC	+12V power supply	
51	VCC	+12V power supply	

4.2.2 41PIN CONNECTOR PIN ASSIGNMENT

Connector Part No.: FI-RE41S-HF (JAE) or equivalent.

Pin	Name	Description	Note
1	N.C.	No Connection	(1)
2	N.C.	No Connection	
3	N.C.	No Connection	
4	N.C.	No Connection	
5	N.C.	No Connection	
6	N.C.	No Connection	
7	N.C.	No Connection	
8	N.C.	No Connection	
9	GND	Ground	
10	CH3[0]-	Third pixel Negative LVDS differential data input. Pair 0	
11	CH3[0]+	Third pixel Positive LVDS differential data input. Pair 0	
12	CH3[1]-	Third pixel Negative LVDS differential data input. Pair 1	
13	CH3[1]+	Third pixel Positive LVDS differential data input. Pair 1	
14	CH3[2]-	Third pixel Negative LVDS differential data input. Pair 2	
15	CH3[2]+	Third pixel Positive LVDS differential data input. Pair 2	
16	GND	Ground	
17	CH3CLK-	Third pixel Negative LVDS differential clock input.	

18	CH3CLK+	Third pixel Positive LVDS differential clock input.	
19	GND	Ground	
20	CH3[3]-	Third pixel Negative LVDS differential data input. Pair 3	
21	CH3[3]+	Third pixel Positive LVDS differential data input. Pair 3	
22	N.C.	No Connection	
23	N.C.	No Connection	
24	GND	Ground	
25	GND	Ground	
26	CH4[0]-	Fourth pixel Negative LVDS differential data input. Pair 0	
27	CH4[0]+	Fourth pixel Positive LVDS differential data input. Pair 0	
28	CH4[1]-	Fourth pixel Negative LVDS differential data input. Pair 1	
29	CH4[1]+	Fourth pixel Positive LVDS differential data input. Pair 1	
30	CH4[2]-	Fourth pixel Negative LVDS differential data input. Pair 2	
31	CH4[2]+	Fourth pixel Positive LVDS differential data input. Pair 2	
32	GND	Ground	
33	CH4CLK-	Fourth pixel Negative LVDS differential clock input.	
34	CH4CLK+	Fourth pixel Positive LVDS differential clock input.	
35	GND	Ground	
36	CH4[3]-	Fourth pixel Negative LVDS differential data input. Pair 3	
37	CH4[3]+	Fourth pixel Positive LVDS differential data input. Pair 3	
38	N.C.	No Connection	
39	N.C.	No Connection	
40	GND	Ground	
41	GND	Ground	

4.2.3 10PIN CONNECTOR PIN ASSIGNMENT

Connector Part No.: LM123S-010-H-TF1-3 (UNICORN) or equivalent.

1	N.C.	No Connection	
2	N.C.	No Connection	
3	N.C.	No Connection	
4	GND	Ground	
5	B/L	Output signal for backlight on/off control signal , H: B/L off, L: B/L on (3D only)	H: +3.3V L: 0V
6	L/R_O	Output signal for Left Right Glasses control	(7)
7	N.C.	No Connection	
8	N.C.	No Connection	
9	N.C.	No Connection	
10	N.C.	No Connection	
1	N.C.	No Connection	

Note (1) Reserved for internal use. Please leave it open.

Note (2) LVDS format selection.

L= Connect to GND , H=Connect to +3.3V or Open

SELLVDS	Note
L	JEDIA Format
H or Open	VESA Format

Note (3) 2D/3D mode selection.

L= Connect to GND or Open, H=Connect to +3.3V

2D/3D	Note
L or Open	2D Mode
H	3D Mode

Note (4) Left Right synchronous signal for glasses.

$V_{IL}=0\sim 0.8\text{ V}$, $V_{IH}=2.0\sim 3.3\text{ V}$

LR	Note
L	Right synchronous
H	Left synchronous signal

Note (5) 2D/3D, and LR signal pin connected to the LCM side has the following diagram.

R1 in the system side should be less than 1K Ohm. ($R1 < 1\text{K Ohm}$)

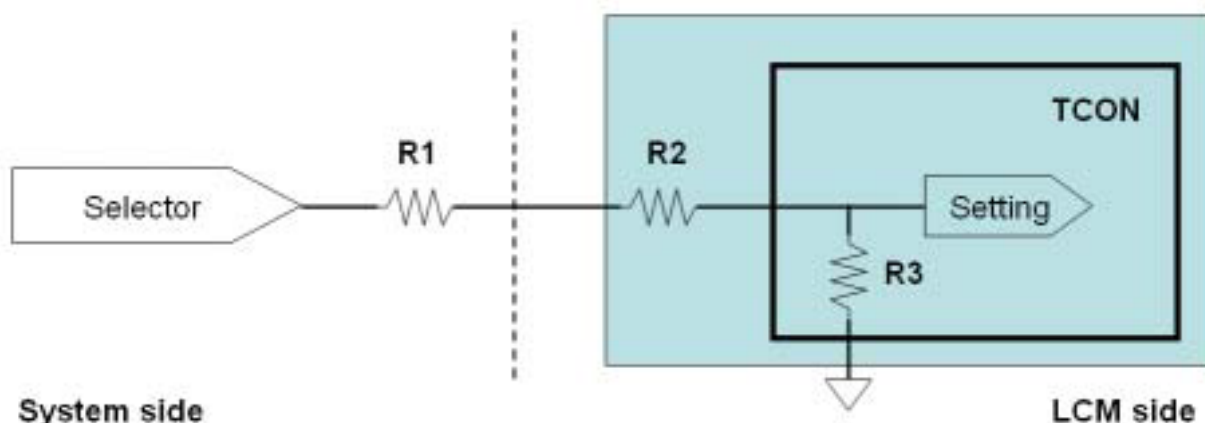

System side: $R1 < 1\text{K}$

Note (6) SELLVDS signal pin connected to the LCM side has the following diagram.

R1 in the system side should be less than 1K Ohm. ($R1 < 1\text{K Ohm}$)

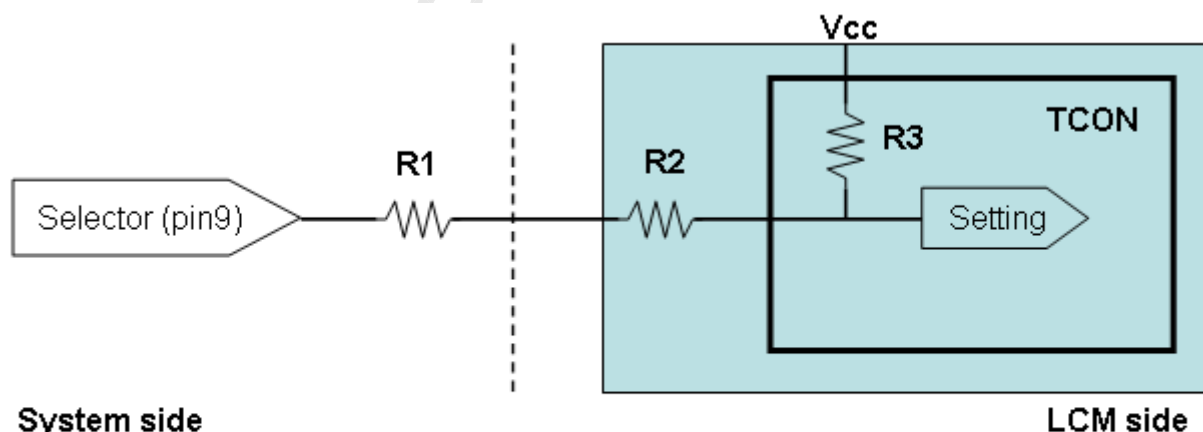

System side
 $R1 < 1\text{K}$

Note (7) The definition of L/R_O signal as follows

L= 0V , H= +3.3V

L/R_O	Note
L	Right glass turn on
H	Left glass turn on

Note (8) LVDS 4-port Data Mapping

Port	Channel of LVDS	Data Stream
1st Port	First Pixel	1, 5, 9,1913, 1917
2nd Port	Second Pixel	2, 6, 10,1914, 1918
3rd Port	Third Pixel	3, 7, 11,1915, 1919
4th Port	Fourth Pixel	4, 8, 12,1916, 1920

4.3 ELECTRICAL CHARACTERISTICS

4.3.1 LCD ELETRONICS SPECIFICATION

Parameter	Symbol	Value			Unit	Note
		Min.	Typ.	Max.		
Power Supply Voltage	V_{CC}	10.8	12	12.6	V	(1)
Ripple Voltage	V_{RP}	-	-	300	mV	-
Rush Current	I_{RUSH}	-	-	3.8	A	(2)
Power Supply Current	White	-	0.35	0.5	A	(3a)
	Black	-	0.64	0.9	A	(3b)
	Vertical Stripe	-	0.64	0.9	A	(3c)
Power Consumption	PLCD	-	7.8	11	Watt	(4)
LVDS differential input voltage	V_{id}	200	-	600	mV	(5)
LVDS common input voltage	V_{ic}	1.0	1.2	1.4	V	-
Logic High Input Voltage	V_{IH}	2.7	-	3.3	V	-
Logic Low Input Voltage	V_{IL}	0	-	0.7	V	-

Note (1) The ambient temperature is $T_a = 25 \pm 2 \text{ }^\circ\text{C}$.

Note (2) Measurement Conditions:

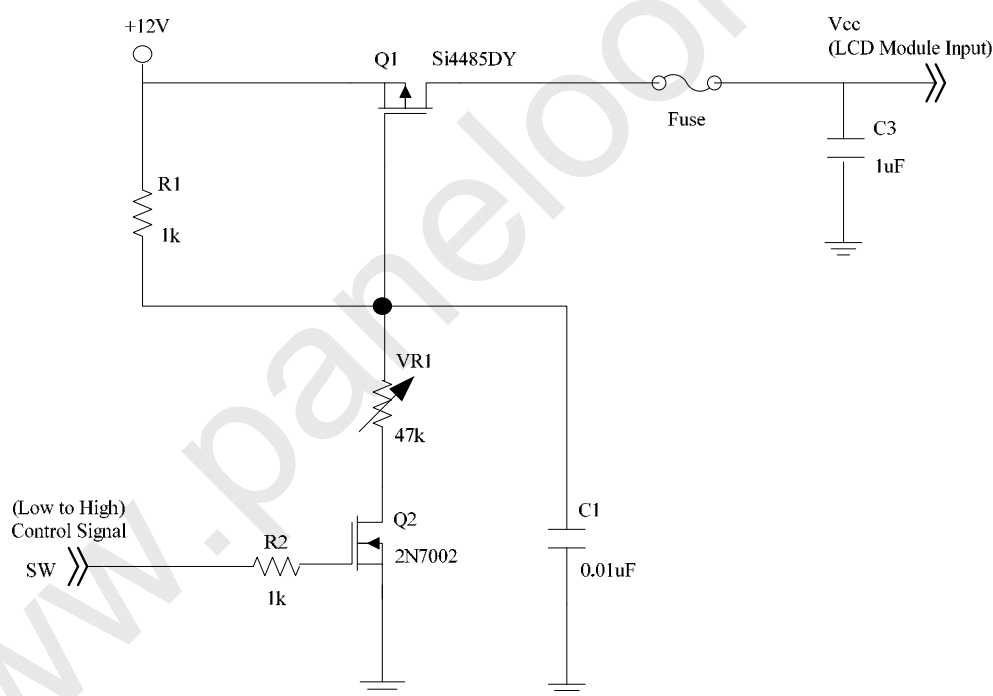

Vcc rising time is 470 μ s

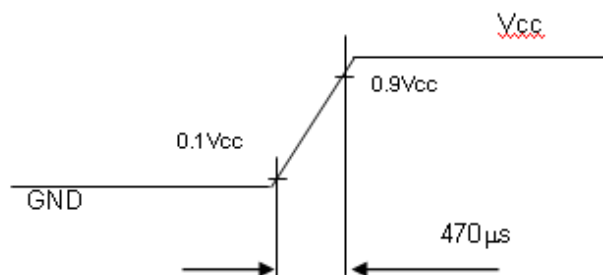

Note (3) The specified power supply current is under the conditions at $V_{CC} = 12.0\text{ V}$, $T_a = 25 \pm 2\text{ }^\circ\text{C}$, $F_r = 120\text{ Hz}$, whereas a power dissipation check pattern below is displayed.

a. White Pattern



Active Area

b. Black Pattern

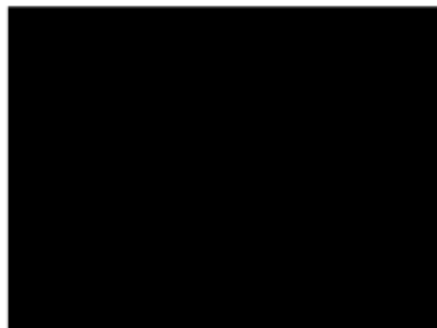

Active Area

c. Vertical Stripe Pattern

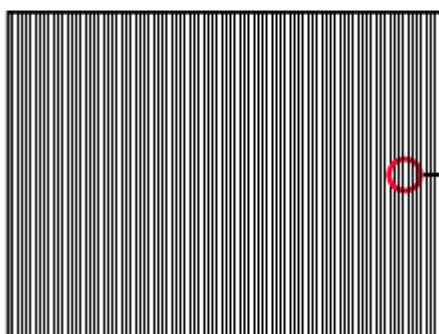

Active Area

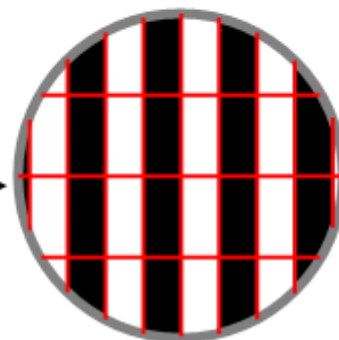

Note (4) The power consumption is specified at the pattern with the maximum current.

Note (5) VID waveform condition

Single-End

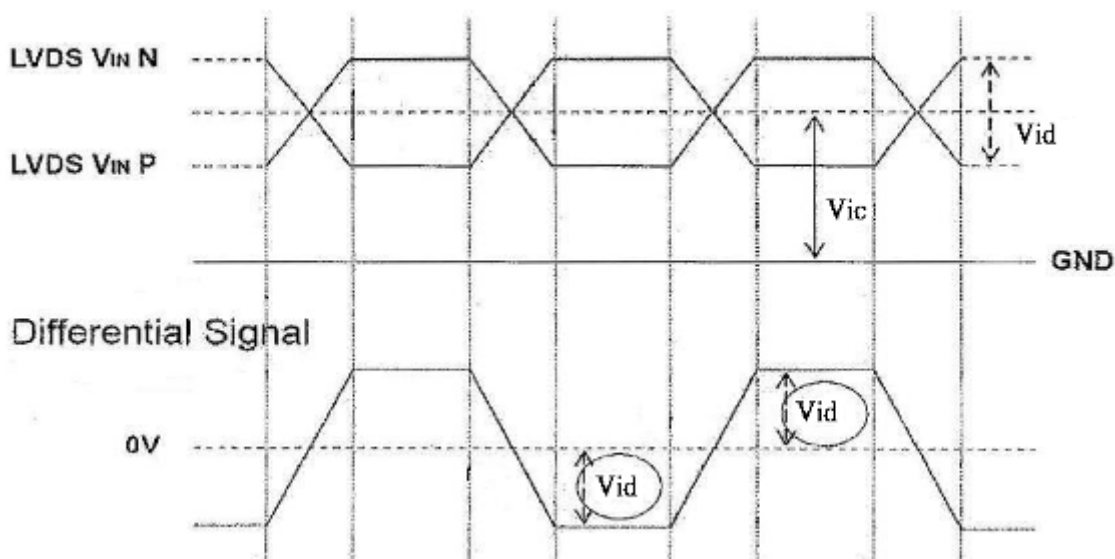

4.3.2 BACKLIGHT UNIT

Normal mode

Parameter	Symbol	Value			Unit	Note
		Min.	Typ.	Max.		
LED Light Bar Input Voltage Per Input Pin	VPIN	33.5	38.4	42	V	(1), Duty=100%, IPIN=40mA
LED Light Bar Current Per Input Pin	IPIN	---	40	56	mA	(1), (2) Duty=100%
LED Life Time	LLED	30000	---	---	Hrs	(3)
Power Consumption	PBL	---	12.3	17.2	W	(1) Duty=100%, IPIN=40mA

Peaking mode(reference only)

Parameter	Symbol	Value			Unit	Note
		Min.	Typ.	Max.		
LED Light Bar Input Voltage Per Input Pin	VPIN	---	42	50.4	V	(1), Duty=18%, IPIN=80mA
LED Light Bar Current Per Input Pin	IPIN	---	80	---	mA	(1), (2) Duty=18%
Power Consumption	PBL	---	4.8	5.8	W	(1) Duty=18%, IPIN=80mA

Note (1) LED light bar input voltage and current are measured by utilizing a true RMS multimeter as shown below:

Note (2) $PBL = IPIN \times VPIN \times (8)$ input pins.

Note (3) The lifetime of LED is defined as the time when LED packages continue to operate under the conditions at $T_a = 25 \pm 2^\circ\text{C}$ and $I = (20)\text{mA}$ (per chip) until the brightness becomes $\leq 50\%$ of its original value.

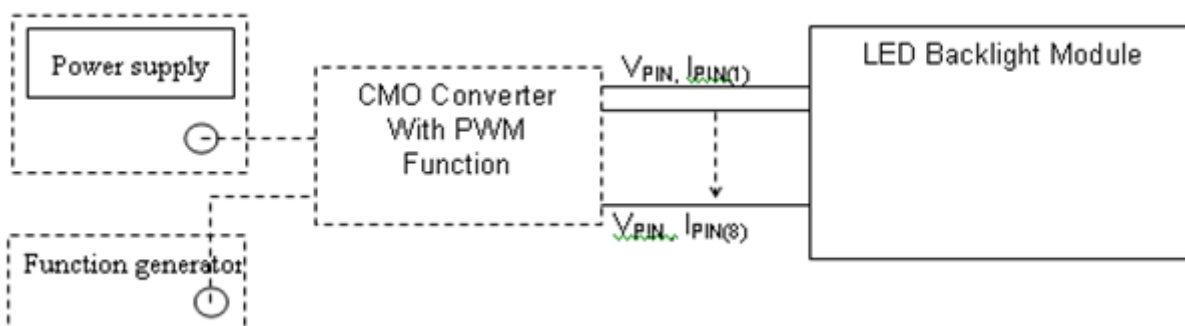

4.3.3 LIGHTBAR Connector Pin Assignment

Connector: 7083K-F12N-00L , (Entry) or Compatible

CN1

Pin number	Description
1	Cathode of LED string
2	Cathode of LED string

3	Cathode of LED string
4	Cathode of LED string
5	Not connection, this pin should be open
6	VLED
7	VLED
8	Not connection, this pin should be open
9	Cathode of LED string
10	Cathode of LED string
11	Cathode of LED string
12	Cathode of LED string

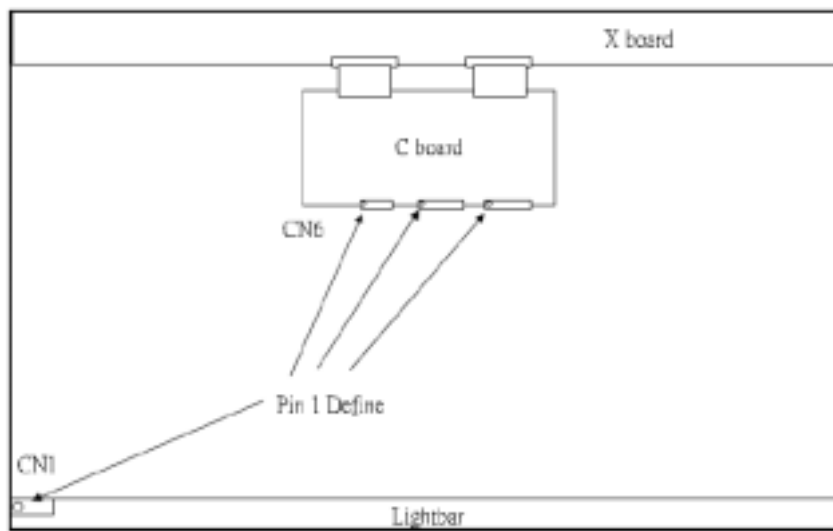

4.4 LVDS INPUT SIGNAL SPECIFICATIONS

4.4.1 LVDS DATA MAPPING TABLE

LVDS Channel O0	LVDS output	D7	D6	D4	D3	D2	D1	D0
	Data order	OG0	OR5	OR4	OR3	OR2	OR1	OR0
LVDS Channel O1	LVDS output	D18	D15	D14	D13	D12	D9	D8
	Data order	OB1	OB0	OG5	OG4	OG3	OG2	OG1
LVDS Channel O2	LVDS output	D26	D25	D24	D22	D21	D20	D19
	Data order	DE	NA	NA	OB5	OB4	OB3	OB2
LVDS Channel O3	LVDS output	D23	D17	D16	D11	D10	D5	D27
	Data order	NA	OB7	OB6	OG7	OG6	OR7	OR6
LVDS Channel E0	LVDS output	D7	D6	D4	D3	D2	D1	D0
	Data order	EG0	ER5	ER4	ER3	ER2	ER1	ER0
LVDS Channel E1	LVDS output	D18	D15	D14	D13	D12	D9	D8
	Data order	EB1	EB0	EG5	EG4	EG3	EG2	EG1
LVDS Channel E2	LVDS output	D26	D25	D24	D22	D21	D20	D19
	Data order	DE	NA	NA	EB5	EB4	EB3	EB2
LVDS Channel E3	LVDS output	D23	D17	D16	D11	D10	D5	D27
	Data order	NA	EB7	EB6	EG7	EG6	ER7	ER6

4.4.2 COLOR DATA INPUT ASSIGNMENT

The brightness of each primary color (red, green and blue) is based on the 8-bit gray scale data input for the color. The higher the binary input, the brighter the color. The table below provides the assignment of color versus data input.

Color		Data Signal																							
		Red								Green								Blue							
		R7	R6	R5	R4	R3	R2	R1	R0	G7	G6	G5	G4	G3	G2	G1	G0	B7	B6	B5	B4	B3	B2	B1	B0
Basic Colors	Black	0	0	0	0	0	0	0	0	0	0	0	0	0	0	0	0	0	0	0	0	0	0	0	0
	Red	1	1	1	1	1	1	1	1	0	0	0	0	0	0	0	0	0	0	0	0	0	0	0	0
	Green	0	0	0	0	0	0	0	0	1	1	1	1	1	1	1	1	0	0	0	0	0	0	0	0
	Blue	0	0	0	0	0	0	0	0	0	0	0	0	0	0	0	0	1	1	1	1	1	1	1	1
	Cyan	0	0	0	0	0	0	0	0	1	1	1	1	1	1	1	1	1	1	1	1	1	1	1	1
	Magenta	1	1	1	1	1	1	1	1	0	0	0	0	0	0	0	0	1	1	1	1	1	1	1	1
	Yellow	1	1	1	1	1	1	1	1	1	1	1	1	1	1	1	1	0	0	0	0	0	0	0	0
	White	1	1	1	1	1	1	1	1	1	1	1	1	1	1	1	1	1	1	1	1	1	1	1	1
Gray Scale Of Red	Red(0) / Dark	0	0	0	0	0	0	0	0	0	0	0	0	0	0	0	0	0	0	0	0	0	0	0	
	Red(1)	0	0	0	0	0	0	0	1	0	0	0	0	0	0	0	0	0	0	0	0	0	0	0	
	Red(2)	0	0	0	0	0	0	1	0	0	0	0	0	0	0	0	0	0	0	0	0	0	0	0	
	⋮	⋮	⋮	⋮	⋮	⋮	⋮	⋮	⋮	⋮	⋮	⋮	⋮	⋮	⋮	⋮	⋮	⋮	⋮	⋮	⋮	⋮	⋮	⋮	
	⋮	⋮	⋮	⋮	⋮	⋮	⋮	⋮	⋮	⋮	⋮	⋮	⋮	⋮	⋮	⋮	⋮	⋮	⋮	⋮	⋮	⋮	⋮	⋮	
	Red(253)	1	1	1	1	1	1	0	1	0	0	0	0	0	0	0	0	0	0	0	0	0	0	0	
	Red(254)	1	1	1	1	1	1	1	0	0	0	0	0	0	0	0	0	0	0	0	0	0	0	0	
	Red(255)	1	1	1	1	1	1	1	1	0	0	0	0	0	0	0	0	0	0	0	0	0	0	0	
Gray Scale Of Green	Green(0) / Dark	0	0	0	0	0	0	0	0	0	0	0	0	0	0	0	0	0	0	0	0	0	0	0	
	Green(1)	0	0	0	0	0	0	0	0	0	0	0	0	0	0	1	0	0	0	0	0	0	0	0	
	Green(2)	0	0	0	0	0	0	0	0	0	0	0	0	0	1	0	0	0	0	0	0	0	0	0	
	⋮	⋮	⋮	⋮	⋮	⋮	⋮	⋮	⋮	⋮	⋮	⋮	⋮	⋮	⋮	⋮	⋮	⋮	⋮	⋮	⋮	⋮	⋮	⋮	
	⋮	⋮	⋮	⋮	⋮	⋮	⋮	⋮	⋮	⋮	⋮	⋮	⋮	⋮	⋮	⋮	⋮	⋮	⋮	⋮	⋮	⋮	⋮	⋮	
	Green(253)	0	0	0	0	0	0	0	0	1	1	1	1	1	1	0	1	0	0	0	0	0	0	0	
	Green(254)	0	0	0	0	0	0	0	0	1	1	1	1	1	1	1	0	0	0	0	0	0	0	0	
	Green(255)	0	0	0	0	0	0	0	0	1	1	1	1	1	1	1	1	0	0	0	0	0	0	0	
Gray Scale Of Blue	Blue(0) / Dark	0	0	0	0	0	0	0	0	0	0	0	0	0	0	0	0	0	0	0	0	0	0	0	
	Blue(1)	0	0	0	0	0	0	0	0	0	0	0	0	0	0	0	0	0	0	0	0	0	0	1	
	Blue(2)	0	0	0	0	0	0	0	0	0	0	0	0	0	0	0	0	0	0	0	0	0	1	0	
	⋮	⋮	⋮	⋮	⋮	⋮	⋮	⋮	⋮	⋮	⋮	⋮	⋮	⋮	⋮	⋮	⋮	⋮	⋮	⋮	⋮	⋮	⋮	⋮	
	⋮	⋮	⋮	⋮	⋮	⋮	⋮	⋮	⋮	⋮	⋮	⋮	⋮	⋮	⋮	⋮	⋮	⋮	⋮	⋮	⋮	⋮	⋮	⋮	
	Blue(253)	0	0	0	0	0	0	0	0	0	0	0	0	0	0	0	1	1	1	1	1	1	1	0	
	Blue(254)	0	0	0	0	0	0	0	0	0	0	0	0	0	0	0	1	1	1	1	1	1	1	0	
	Blue(255)	0	0	0	0	0	0	0	0	0	0	0	0	0	0	0	1	1	1	1	1	1	1	1	

Note (1) 0: Low Level Voltage, 1: High Level Voltage

4.5 DISPLAY TIMING SPECIFICATIONS

(Ta = 25 ± 2 °C)

The input signal timing specifications are shown as the following table and timing diagram.

Signal	Item	Symbol	Min.	Typ.	Max.	Unit	Note
LVDS Receiver Clock	Frequency	$F_{clk_{in}}$ (=1/TC)	60	74.25	96.23	MHz	-
	Input cycle to cycle jitter	T_{rcl}	-	-	200	ps	(3)
	Spread spectrum modulation range	$F_{clk_{in_mod}}$	$F_{clk_{in}}-2\%$	-	$F_{clk_{in}}+2\%$	MHz	(4)
	Spread spectrum modulation frequency	F_{SSM}	-	-	200	KHz	
LVDS Receiver Data	Setup Time	$Tlvsu$	600	-	-	ps	(5)
	Hold Time	$Tlvhd$	600	-	-	ps	

4.5.1 TIMING SPEC FOR FRAME RATE ($F_{r5} = 100\text{Hz}$)

Signal	Item	Symbol	Min.	Typ.	Max.	Unit	Note	
Vertical Active Display Term	2D Mode	Total	T_v	1115	1125	1135	Th	$T_v = T_{vd} + T_{vb}$
		Display	T_{vd}	1080	1080	1080	Th	-
		Blank	T_{vb}	35	45	55	Th	-
	3D Mode	Total	T_v	1524			Th	(6)
		Display	T_{vd}	1080			Th	
		Blank	T_{vb}	444			Th	
Horizontal Active Display Term	2D Mode	Total	T_h	540	550	575	Tc	$T_h = T_{hd} + T_{hb}$
		Display	T_{hd}	480	480	480	Tc	-
		Blank	T_{hb}	60	70	95	Tc	-
	3D Mode	Total	T_h	525			Tc	(7)
		Display	T_{hd}	480			Tc	
		Blank	T_{hb}	45			Tc	

4.5.2 TIMING SPEC FOR FRAME RATE ($F_{r6} = 120\text{Hz}$)

Signal	Item	Symbol	Min.	Typ.	Max.	Unit	Note	
Vertical Active Display Term	2D Mode	Total	T_v	1115	1125	1135	Th	$T_v = T_{vd} + T_{vb}$
		Display	T_{vd}	1080	1080	1080	Th	-

	3D Mode	Blank	Tvb	35	45	55	Th	—
		Total	Tv	1524			Th	(6)
		Display	Tvd	1080			Th	
		Blank	Tvb	444			Th	
Horizontal Active Display Term	2D Mode	Total	Th	540	550	575	Tc	Th=Thd+Thb
		Display	Thd	480	480	480	Tc	—
		Blank	Thb	60	70	95	Tc	—
	3D Mode	Total	Th	525			Tc	(7)
		Display	Thd	480			Tc	
		Blank	Thb	45			Tc	

Note (1) Since the module is operated in DE only mode, Hsync and Vsync input signals should be set to low logic level. Otherwise, this module would operate abnormally.

Note (2) Please make sure the range of pixel clock has follow the below equation:

$$F_{clk}(max) \geq Fr_6 \times Tv \times Th$$

$$Fr_5 \times Tv \times Th \geq F_{clk}(min)$$

INPUT SIGNAL TIMING DIAGRAM

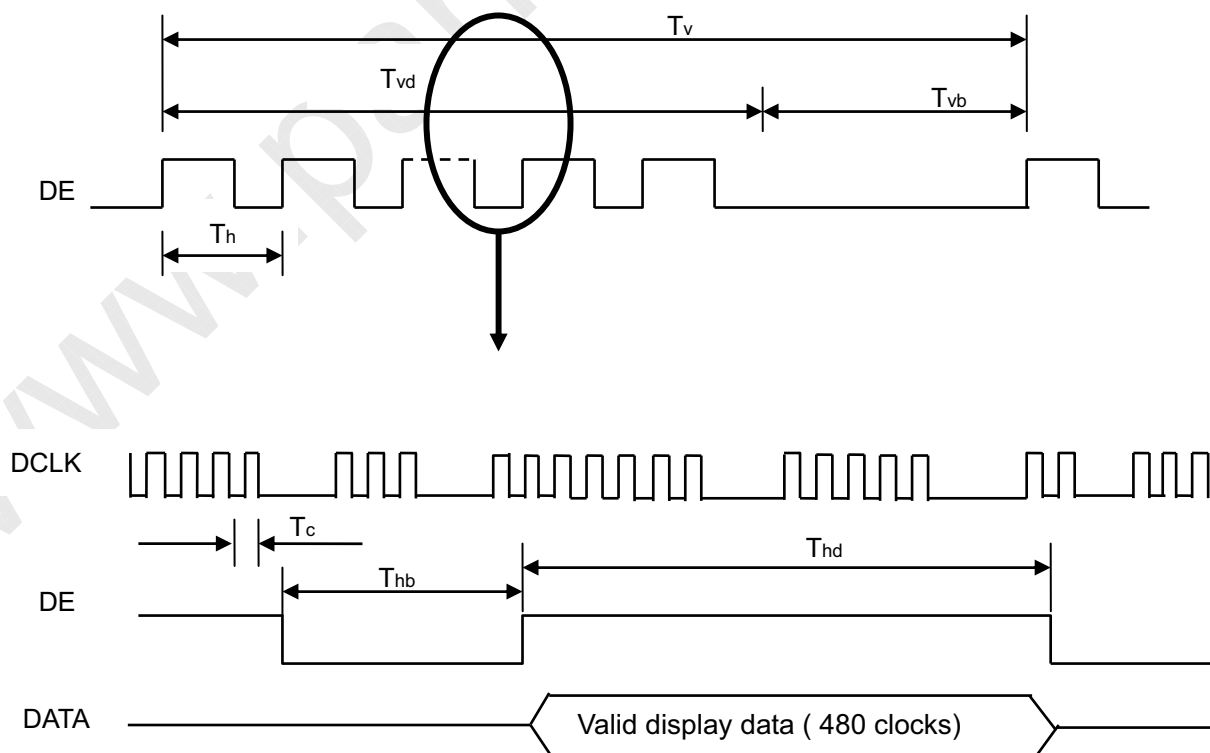

Note (3) The input clock cycle-to-cycle jitter is defined as below figures. $Trcl = |T_1 - T_1|$

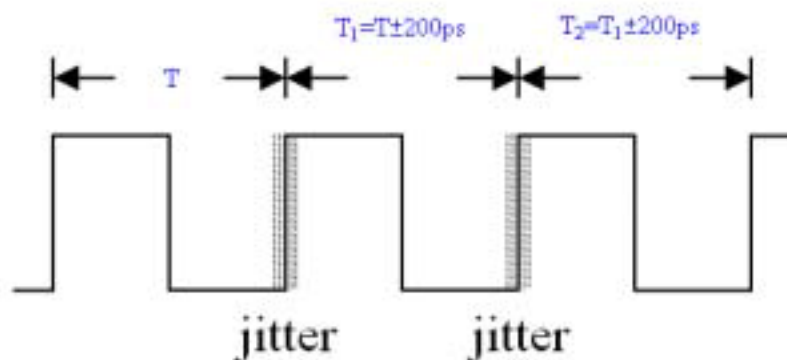

Note (4) The SSCG (Spread spectrum clock generator) is defined as below figures.

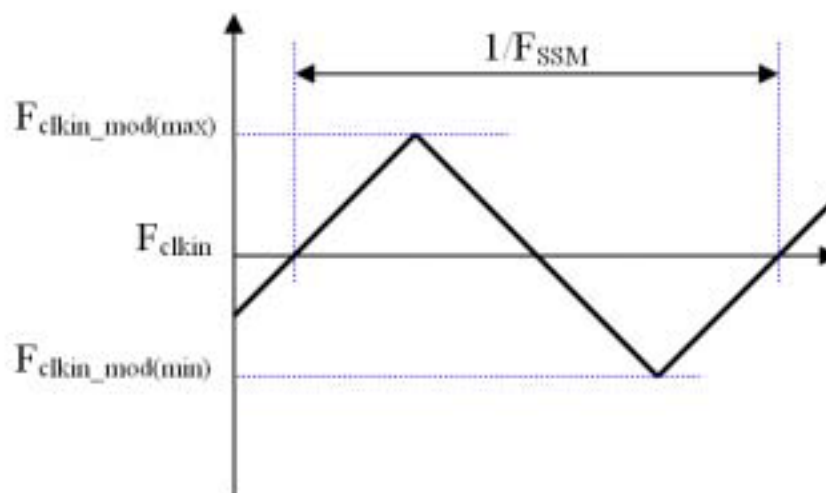

Note (5) The LVDS timing diagram and setup/hold time is defined and showing as the following figures.

LVDS RECEIVER INTERFACE TIMING DIAGRAM

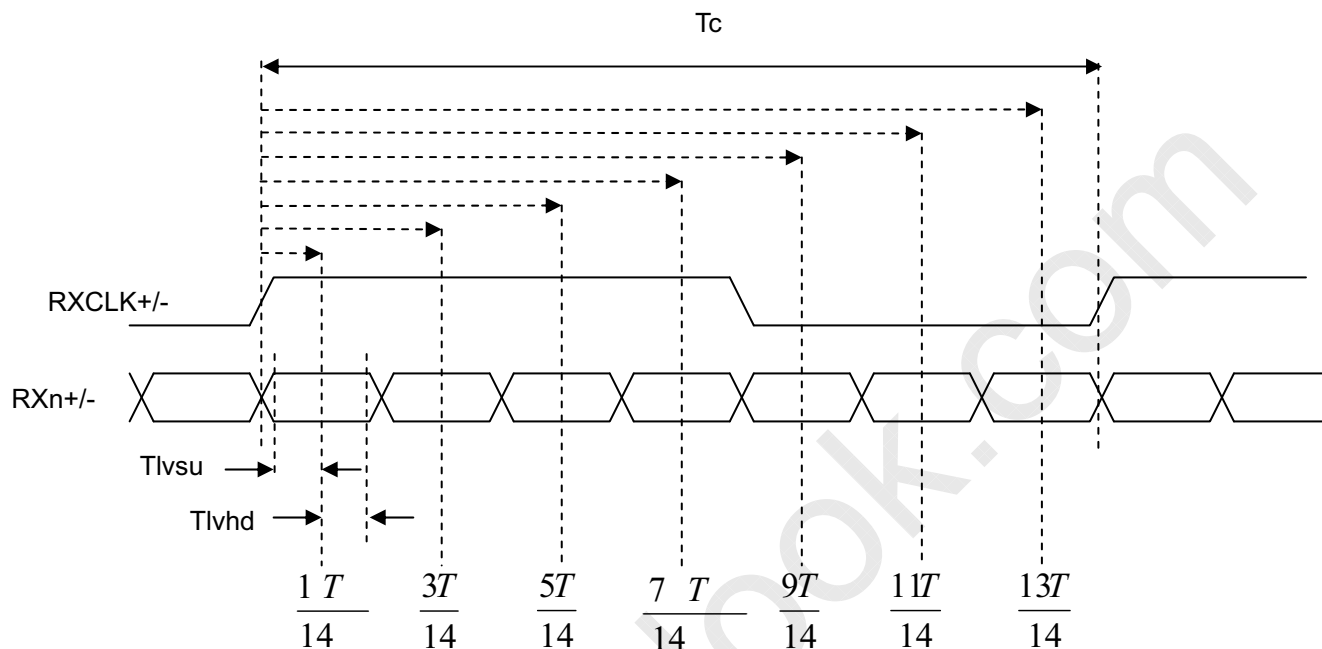

Note (6) Please fix the Vertical timing (Vertical Total =1524 / Display =1080 / Blank = 444) in 3D mode.

Note (7) Please fix the Horizontal timing (Horizontal Total =2100 / Display =1920 / Blank = 180) in 3D mode

4.6 POWER ON/OFF SEQUENCE

4.6.1 POWER ON/OFF SEQUENCE ($T_a = 25 \pm 2 \text{ } ^\circ\text{C}$)

The power sequence specifications are shown as the following table and diagram.

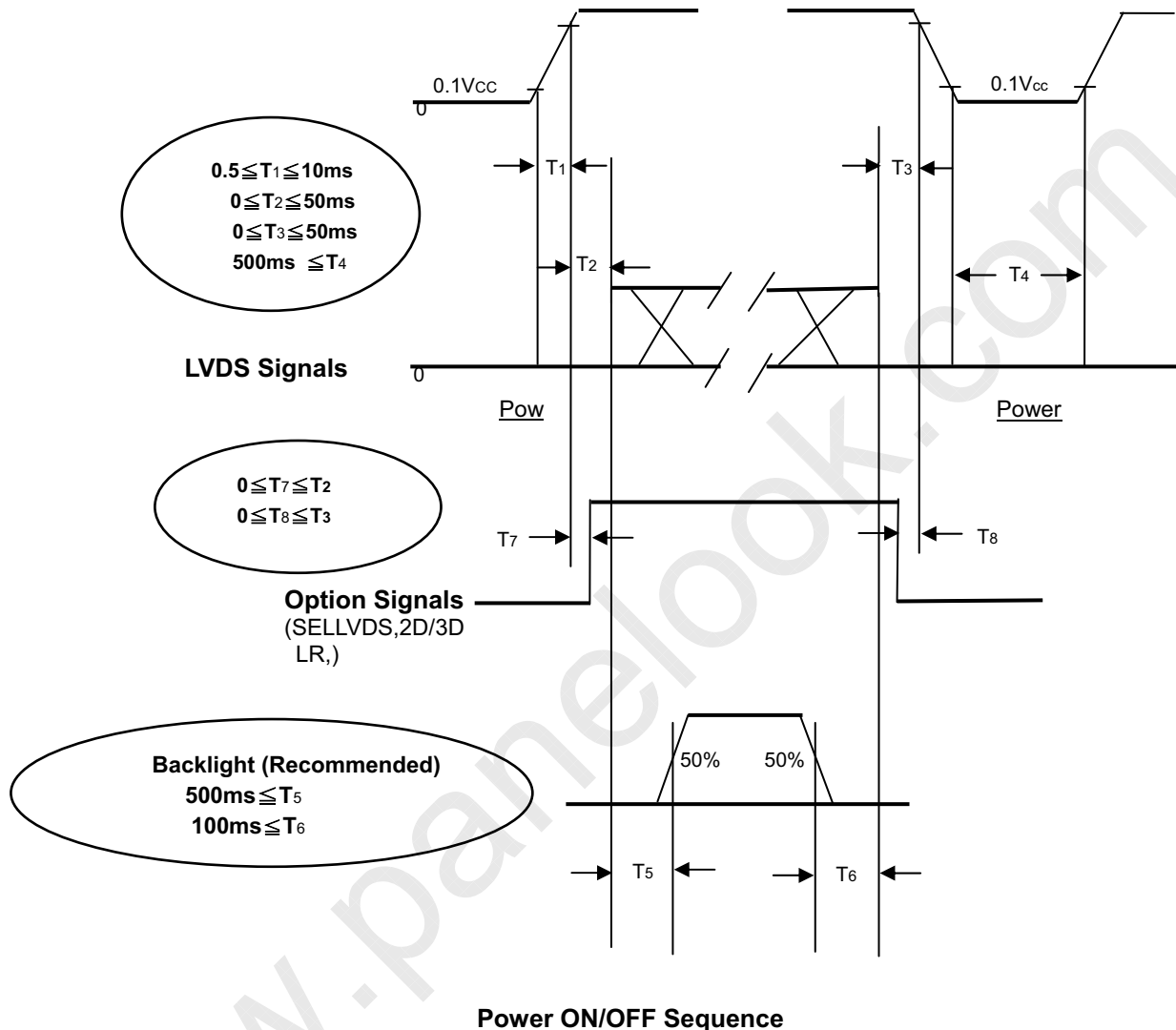

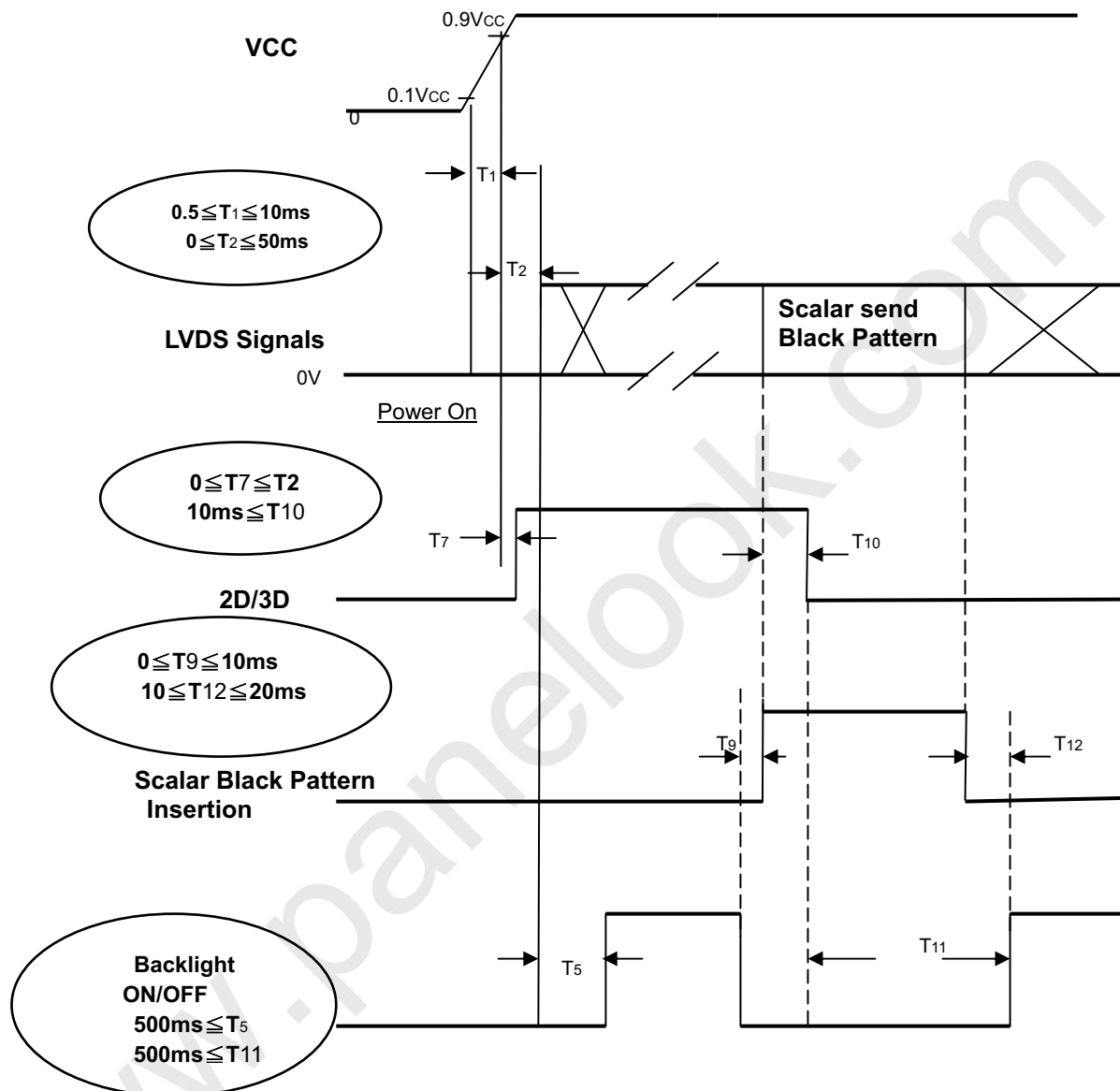
4.6.2 2D to 3D SIGNAL SEQUENCE WITHOUT VCC TURN OFF AND TURN ON

Note (1) The supply voltage of the external system for the module input should follow the definition of Vcc.

Note (2) Apply the LED voltage within the LCD operation range. When the backlight turns on before the LCD operation or the LCD turns off before the backlight turns off, the display may momentarily become abnormal screen.

Note (3) In case of Vcc is in off level, please keep the level of input signals on the low or high impedance. If $T_2 < 0$, that maybe cause electrical overstress failure.

Note (4) T4 should be measured after the module has been fully discharged between power off and on period. Interface signal shall not be kept at high impedance when the power is on.

5. OPTICAL CHARACTERISTICS

5.1 TEST CONDITIONS

Item	Symbol	Value	Unit
Ambient Temperature	Ta	25±2	°C
Ambient Humidity	Ha	50±10	%RH
Supply Voltage	V _{CC}	5	V
Input Signal	According to typical value in "3. ELECTRICAL CHARACTERISTICS"		
LED Light Bar Input Current Per Input Pin	I _{PIN}	40 ± 1.2	mA _{DC}
PWM Duty Ratio	D	100	%
LED Light Bar Test Converter	CMI 27-D041745		

5.2 OPTICAL SPECIFICATIONS

The relative measurement methods of optical characteristics are shown in 5.2. The following items should be measured under the test conditions described in 5.1 and stable environment shown in Note (5).

Item	Symbol	Condition	Min.	Typ.	Max.	Unit	Note	
Color Chromaticity (CIE 1931)	Red	R _x	θ _x =0°, θ _y =0° CS-2000 R=G=B=255 Gray scale	Typ - 0.03	0.641	Typ + 0.03	-	(1), (5)
		R _y			0.339			
	Green	G _x			0.308			
		G _y			0.618			
	Blue	B _x			0.159			
		B _y			0.059			
	White	W _x			0.313			
		W _y			0.329			
Center Luminance of White (Center of Screen)	L _c	2D	250	300	-	cd/m ²	(4), (5)	
		3D	-	26	-	cd/m ²	(8)	
Contrast Ratio	CR		700	1000	-	-	(2), (5)	
Response Time	T _R	θ _x =0°, θ _y =0°	-	0.8	2.5	ms	(3)	
	T _F		-	2.6	5.5			
White Variation	W	θ _x =0°, θ _y =0°	70	-	-	%	(5), (6)	
Crosstalk	CT	3D-W	-	0.4	-	%	(8)	
		3D-D	-	20	-	%		
Viewing Angle	Horizontal	x- + x+	CR ≥ 10	150	170	-	Deg.	(1), (5)
	Vertical	y- + y+		140	160	-		
Viewing Angle	Horizontal	x- + x+	CR ≥ 5	160	178	---	Deg.	(1), (5)
	Vertical	y- + y+		150	170	---		
Absorption direction of the up polarizer	Φ _{up}	-	-	45	-	Deg.	(7)	

Note (1) Definition of Viewing Angle (θ_x , θ_y):

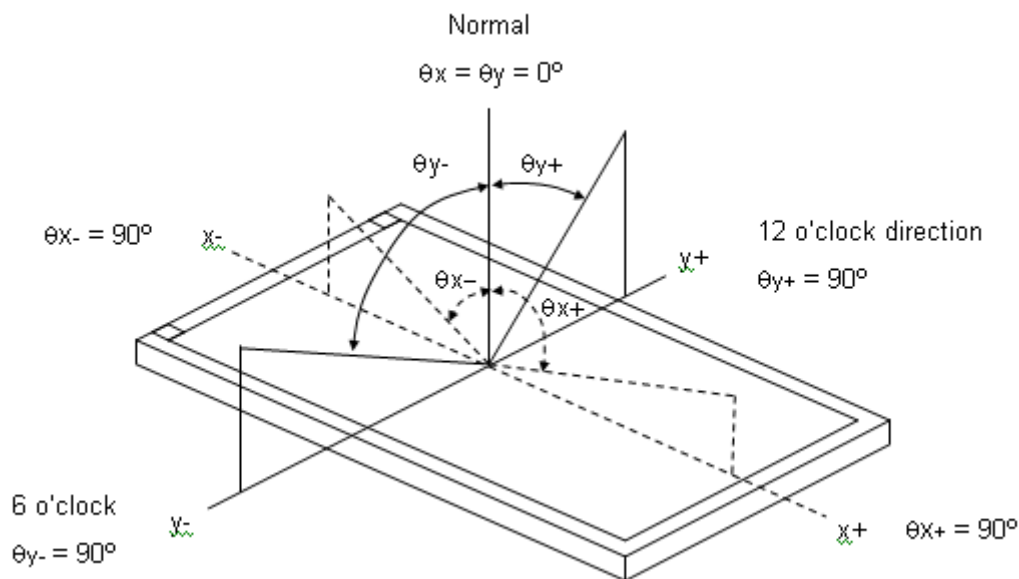

Note (2) Definition of Contrast Ratio (CR):

The contrast ratio can be calculated by the following expression.

$$\text{Contrast Ratio (CR)} = L_{255} / L_0$$

L₂₅₅: Luminance of gray level 255

L₀: Luminance of gray level 0

$$\text{CR} = \text{CR} (5)$$

CR (X) is corresponding to the Contrast Ratio of the point X at Figure in Note (6).

Note (3) Definition of Response Time (T_R , T_F):

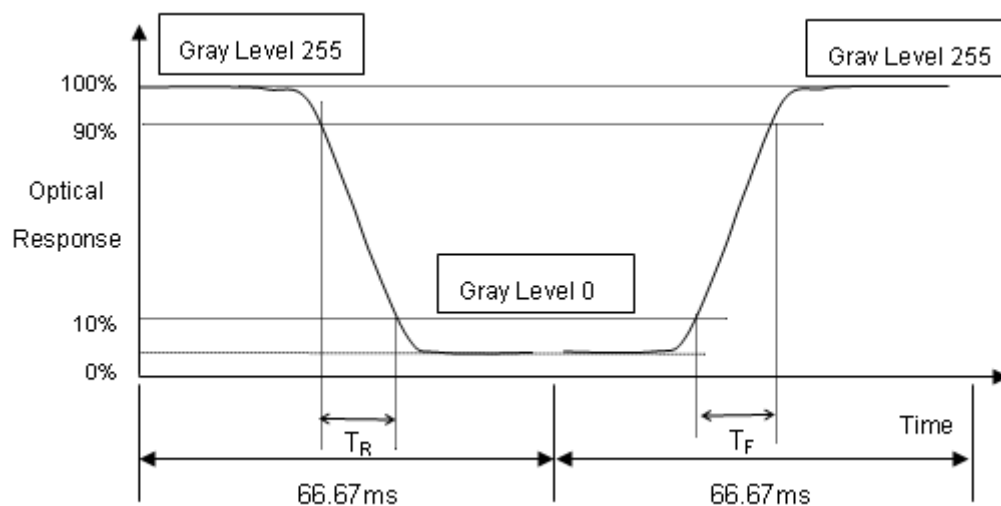

Note (4) Definition of Luminance of White (L_c):

Measure the luminance of gray level 255 at center point

$$L_c = L(5)$$

$L(x)$ is corresponding to the luminance of the point X at Figure in Note (6).

Note (5) Measurement Setup:

The LCD module should be stabilized at given temperature for 40 minutes to avoid abrupt temperature change during measuring. In order to stabilize the luminance, the measurement should be executed after lighting Backlight for 40 minutes in a windless room.

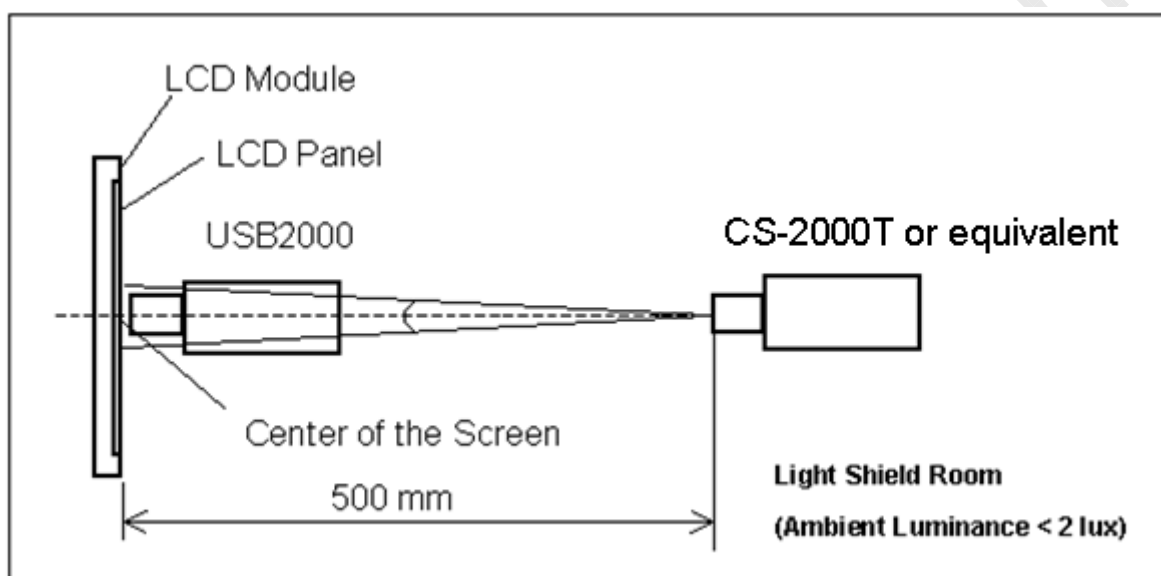

Note (6) Definition of White Variation (δW):

Measure the luminance of gray level 255 at 9 points

$$\delta W = (\text{Minimum } [L(1) \sim L(9)] / \text{Maximum } [L(1) \sim L(9)]) * 100\%$$

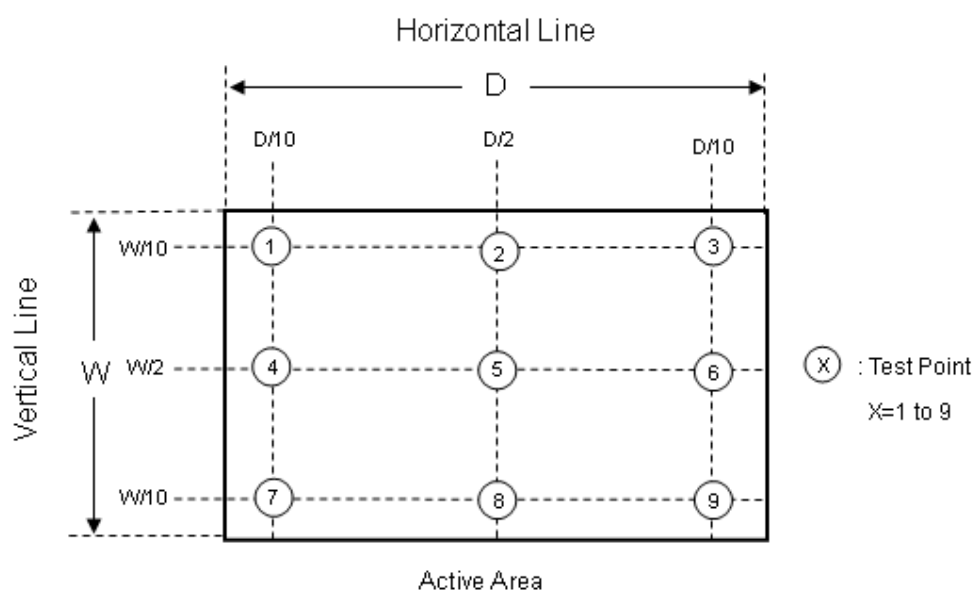

Note (7) This is a reference for designing the shutter glasses of 3D application. (TN case)

Definition of the absorption direction of the up polarizer:

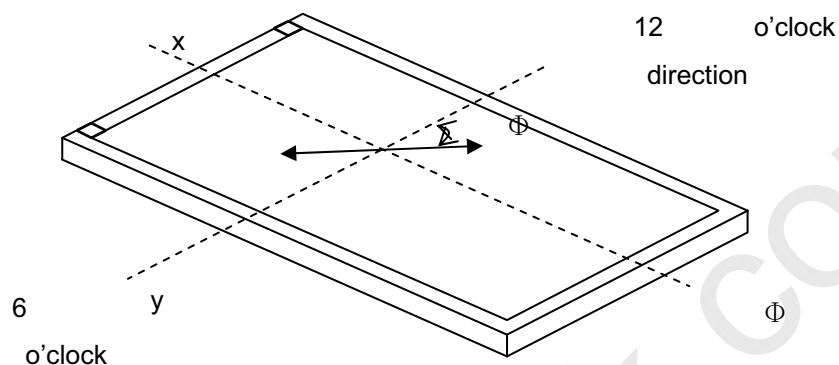



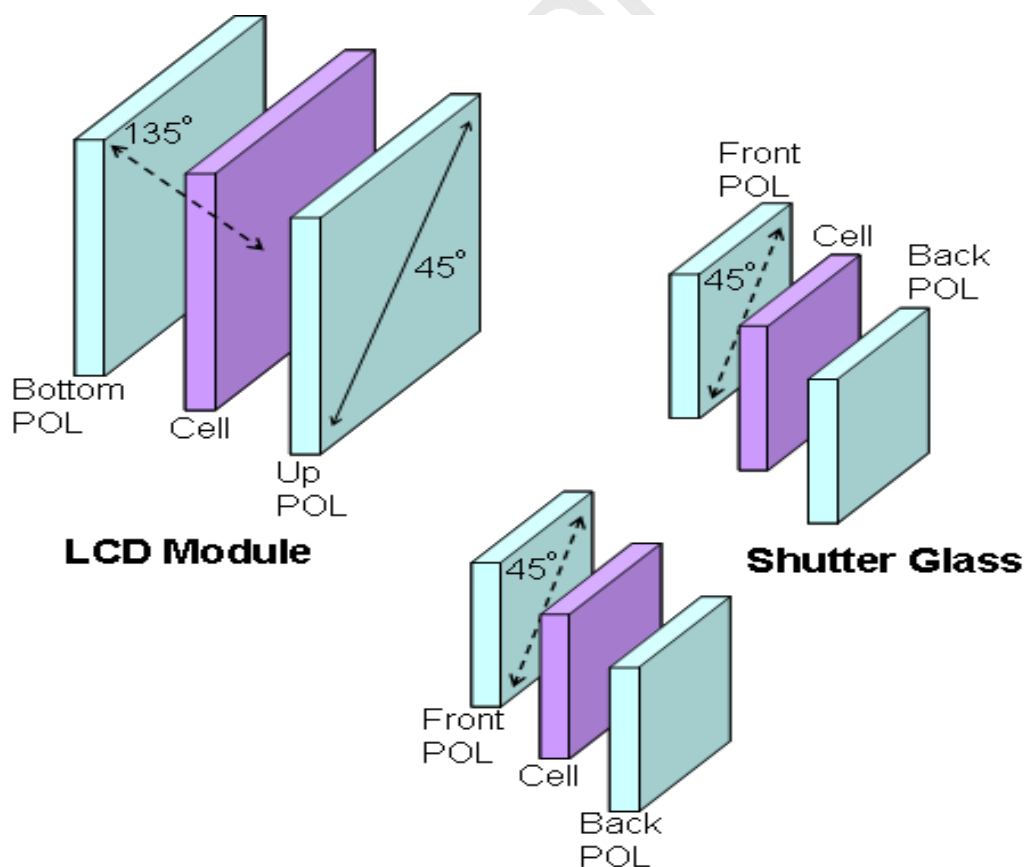



The absorption axis of the front polarizer of the shutter glasses should be parallel to this panel absorption direction to get a maximum 3D mode luminance.

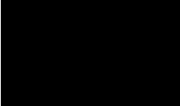

Note(8) Definition of the 3D mode performance (measured under 3D mode):

a. Test pattern

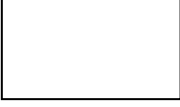
Left eye image and right eye image are displayed alternated

		WW	Left eye image: W255; Right eye image: W255
		WB	Left eye image: W255; Right eye image: W0
		BW	Left eye image: W0; Right eye image: W255
		BB	Left eye image: W0; Right eye image: W0

b. Measurement setup

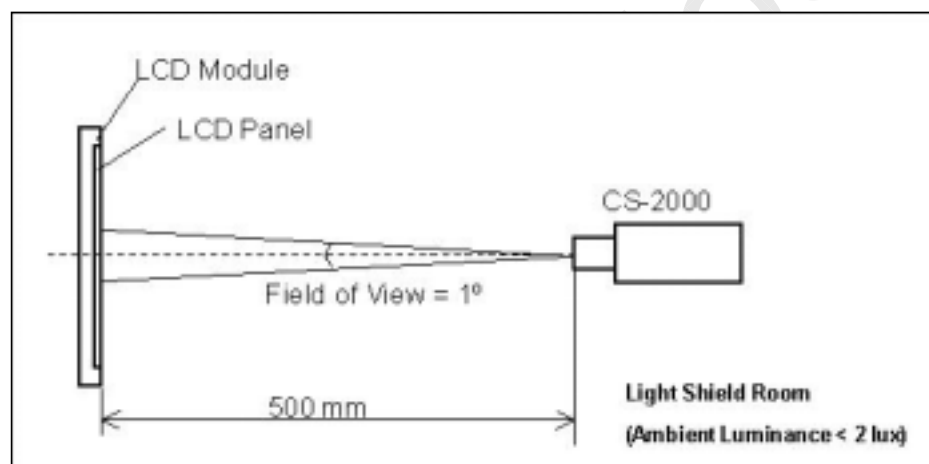

Shutter glasses are well controlled under suitable timing, and measure the luminance of the center point of the panel through the right eye glass. The transmittance of the glass should be larger than 40.0% under 3D mode operation.

The luminance of the test pattern "WW", denoted $L(WW)$; the luminance of the test pattern "WB", denoted $L(WB)$; the luminance of the test pattern "BW", denoted $L(BW)$; the luminance of the test pattern "BB", denoted $L(BB)$

c. Definition of the Center Luminance of White, $L_c(3D) : L(WW)$

d. Definition of the 3D mode white crosstalk, CT (3D-W) : $CT(3D-W) \equiv \frac{L(WB) - L(BB)}{L(WW) - L(BB)}$

Definition of the 3D mode dark crosstalk, CT (3D-D) : $CT(3D-D) \equiv \frac{L(WW) - L(BW)}{L(WW) - L(BB)}$

6. RELIABILITY TEST ITEM

Items	Required Condition	Note
Temperature Humidity Bias (THB)	Ta= 50°C , 80%RH, 240hours	
High Temperature Operation (HTO)	Ta= 50°C , 50%RH , 240hours	
Low Temperature Operation (LTO)	Ta= 0°C , 240hours	
High Temperature Storage (HTS)	Ta= 60°C , 240hours	
Low Temperature Storage (LTS)	Ta= -20°C , 240hours	
Vibration Test (Non-operation)	Acceleration: 1.5 Grms Wave: Half-sine Frequency: 10 - 300 Hz Sweep: 30 Minutes each Axis (X, Y, Z)	
Shock Test (Non-operation)	Acceleration: 50 G Wave: Half-sine Active Time: 11 ms Direction : ± X, ± Y, ± Z.(one time for each Axis)	
Thermal Shock Test (TST)	-20°C/30min , 60°C / 30min , 100 cycles	
On/Off Test	25°C , On/10sec , Off /10sec , 30,000 cycles	
ESD (Electro Static Discharge)	Contact Discharge: ± 8KV, 150pF(330Ω)	
	Air Discharge: ± 15KV, 150pF(330Ω)	
Altitude Test	Operation:10,000 ft / 24hours	
	Non-Operation:30,000 ft / 24hours	

Note (1) criteria : Normal display image with no obvious non-uniformity and no line defect.

Note (2) Evaluation should be tested after storage at room temperature for more than two hour

Note (3) At testing Vibration and Shock, the fixture in holding the module has to be hard and rigid enough so that the module would not be twisted or bent by the fixture.

The fixing condition is shown as below:

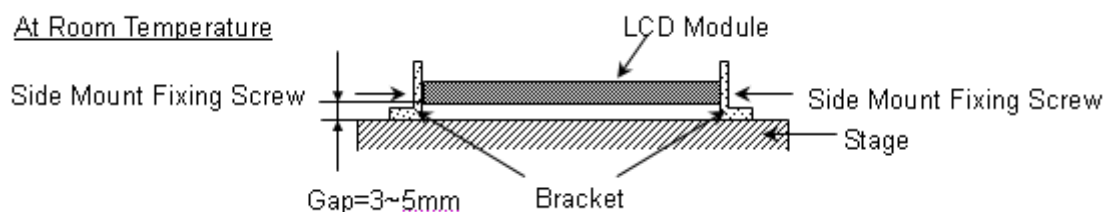

7. PACKING

7.1 PACKING SPECIFICATIONS

- (1) 11 LCD modules / 1 Box
- (2) Box dimensions: 620(L) X 348(W) X 430(H) mm
- (3) Weight: approximately: 30.5kg (11 modules per box)

7.2 PACKING METHOD

- (1) Carton Packing should have no failure in the following reliability test items.

Test Item	Test Conditions	Note
Vibration	ISTA STANDARD Random, Frequency Range: 1 – 200 Hz Top & Bottom: 30 minutes (+Z), 10 min (-Z), Right & Left: 10 minutes (X) Back & Forth 10 minutes (Y)	Pass
Dropping Test	1 Corner , 3 Edge, 6 Face, 31cm	Pass

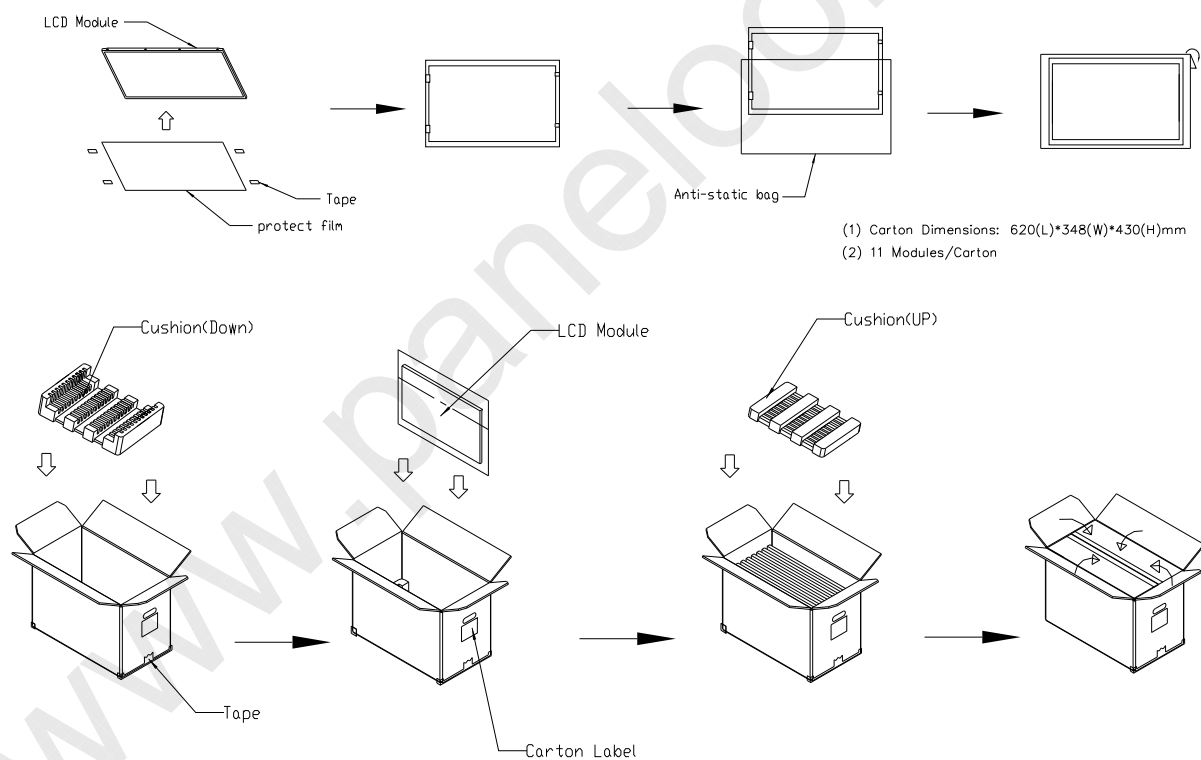
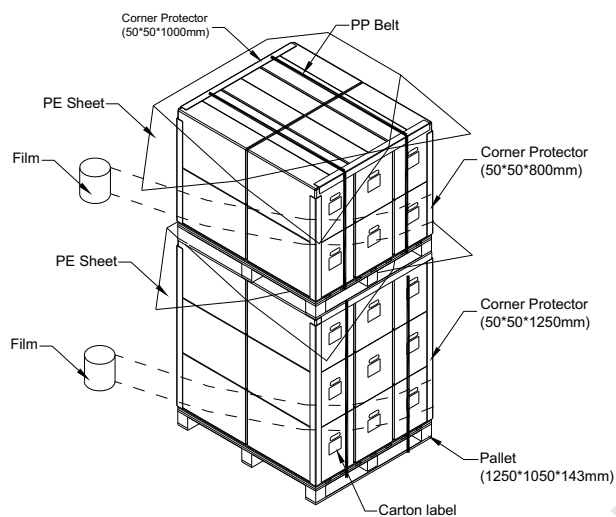

Figure. 7-1 Packing method

7.3 PALLET

For ocean shipping

Sea / Land Transportation (40ft HQ Container)



Sea / Land Transportation (40ft Container)

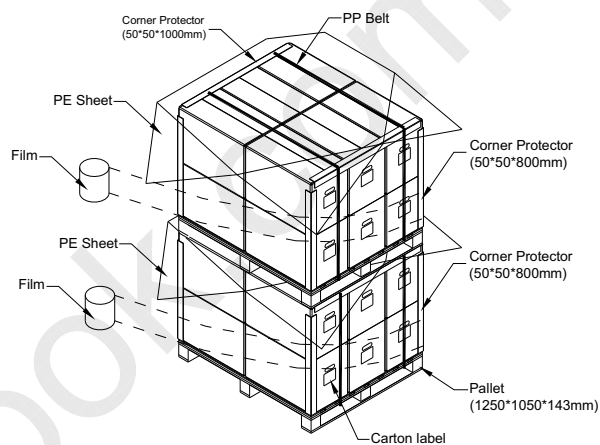

For air transport

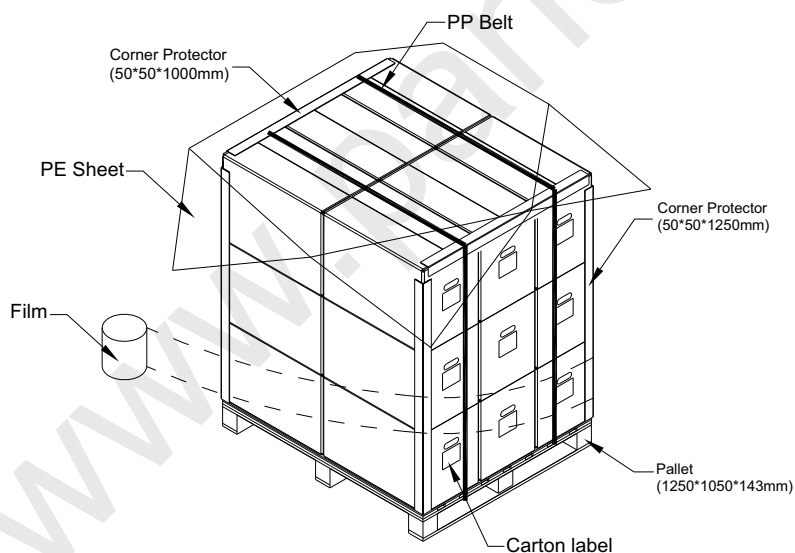

Figure. 7-2 Packing method

8. CMI MODULE LABEL

The barcode nameplate is pasted on each module as illustration, and its definitions are as following explanation.



(a) Model Name: M236HHF-L11

(b) Revision: Rev. XX, for example: A0, A1... B1, B2... or C1, C2...etc.

(c) CMI barcode definition:

Serial ID: XX-XX-X-XX-YMD-L-NNNN

Code	Meaning	Description
XX	CMI internal use	-
XX	Revision	Cover all the change
X	CMI internal use	-
XX	CMI internal use	-
YMD	Year, month, day	Year: 0~9, 2001=1, 2002=2, 2003=3...2010=0, 2011=1, 2012=2... Month: 1~12=1, 2, 3, ~, 9, A, B, C Day: 1~31=1, 2, 3, ~, 9, A, B, C, ~, W, X, Y, exclude I, O, and U.
L	Product line #	Line 1=1, Line 2=2, Line 3=3, ...
NNNN	Serial number	Manufacturing sequence of product

(d) Customer's barcode definition:

Serial ID: CM-N6F11-X-X-X-XX-L-XX-L-YMD-NNNN

Code	Meaning	Description
CM	Supplier code	CMI=CM
N6F11	Model number	M236HHF-L11= N6F11
X	Revision code	Non ZBD: 1,2,~,8,9 / ZBD: A~Z
X	Source driver IC code	Century=1, CLL=2, Demos=3, Epson=4, Fujitsu=5, Himax=6, Hitachi=7, Hynix=8, LDI=9, Matsushita=A, NEC=B, Novatec=C, OKI=D, Philips=E, Renasas=F, Samsung=G, Sanyo=H, Sharp=I, TI=J, Topro=K, Toshiba=L, Windbond=M, ILITEK=Q, Fiti=Y, None IC =Z
X	Gate driver IC code	
XX	Cell location	Tainan Taiwan=TN, Ningbo China=CN, Hsinchu Taiwan=SC
L	Cell line #	1,2,~,9,A,B,~,Y,Z
XX	Module location	Tainan, Taiwan=TN ; Ningbo China=NP, Shenzhen China=SH
L	Module line #	1,2,~,9,A,B,~,Y,Z
YMD	Year, month, day	Year: 0~9, 2001=1, 2002=2, 2003=3...2010=0, 2011=1, 2012=2... Month: 1~12=1, 2, 3, ~, 9, A, B, C Day: 1~31=1, 2, 3, ~, 9, A, B, C, ~, T, U, V
NNNN	Serial number	By LCD supplier

(e) FAB ID(UL Factory ID):

Region	Factory ID
TWCM1	GEMN
NBCMI	LEOO
NBCME	CANO
NHCM1	CAPG

9. PRECAUTIONS

9.1 ASSEMBLY AND HANDLING PRECAUTIONS

- (1) Do not apply rough force such as bending or twisting to the module during assembly.
- (2) To assemble or install module into user's system can be only in clean working areas. The dust and oil may cause electrical short or worsen the polarizer.
- (3) It's not permitted to have pressure or impulse on the module because the LCD panel and Backlight will be damaged.
- (4) Always follow the correct power sequence when LCD module is connecting and operating. This can prevent damage to the CMOS LSI chips during latch-up.
- (5) Do not pull the I/F connector in or out while the module is operating.
- (6) Do not disassemble the module.
- (7) Use a soft dry cloth without chemicals for cleaning, because the surface of polarizer is very soft and easily scratched.
- (8) It is dangerous that moisture come into or contacted the LCD module, because moisture may damage LCD module when it is operating.
- (9) High temperature or humidity may reduce the performance of module. Please store LCD module within the specified storage conditions.
- (10) When ambient temperature is lower than 10°C may reduce the display quality. For example, the response time will become slowly.

9.2 STORAGE PRECAUTIONS

- (1) Do not leave the module in high temperature, and high humidity for a long time. It is highly recommended to store the module with temperature from 0°C to 35°C and relative humidity of less than 70%
- (2) Do not store the TFT – LCD module in direct sunlight
- (3) The module should be stored in dark place. It is prohibited to apply sunlight or fluorescent light in storing

9.3 OPERATION PRECAUTIONS

- (1) The LCD product should be operated under normal condition.

Normal condition is defined as below :

Temperature : 20±15°C

Humidity: 65±20%

Display pattern : continually changing pattern(Not stationary)

- (2) If the product will be used in extreme conditions such as high temperature, high humidity, high altitude, display pattern or operation time etc...It is strongly recommended to contact CMI for application engineering advice. Otherwise, its reliability and function may not be guaranteed.

9.4 SAFETY PRECAUTIONS

- (1) If the liquid crystal material leaks from the panel, it should be kept away from the eyes or mouth. In case of contact with hands, skin or clothes, it has to be washed away thoroughly with soap.
- (2) After the module's end of life, it is not harmful in case of normal operation and storage.

9.5 SAFETY STANDARDS

The LCD module should be certified with safety regulations as follows:

Requirement	Standard	remark
UL	UL60950-1:2006 or Ed.2:2007	
cUL/CSA	CAN/CSA C22.2 No.60950-1-03 or 60950-1-07	
CB	IEC60950-1:2005 / EN60950-1:2006+ A11:2009	

9.6 OTHER

When fixed patterns are displayed for a long time, remnant image is likely to occur.

Appendix. OUTLINE DRAWING

NOTE: OIP POSITION OF STRUCTURE SHOULD NOT TOUCH THE POSITION OF DATA OIP.

NOTE: OIP POSITION OF STRUCTURE SHOULD NOT TOUCH THE POSITION OF DATA OIP.

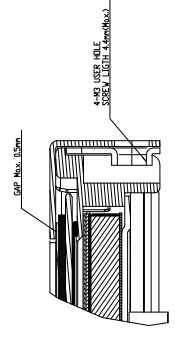
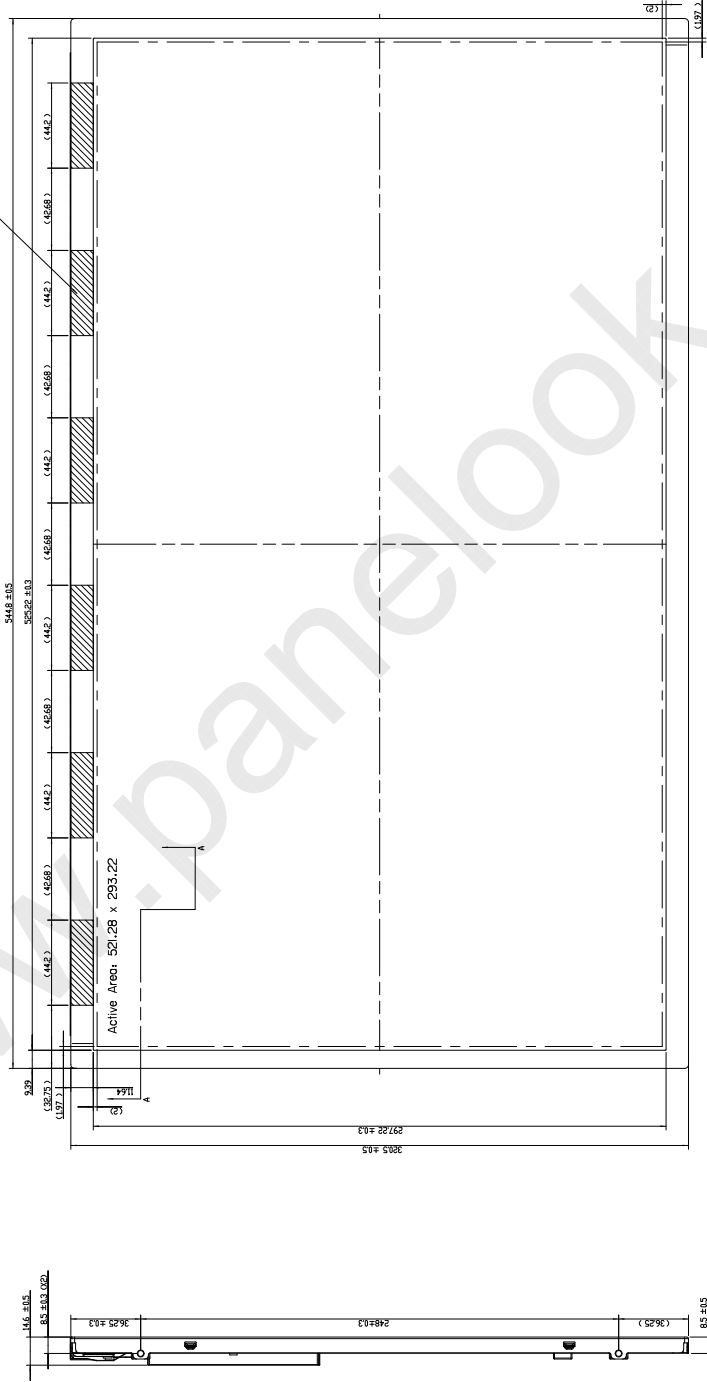

NOTE:
 1. DISPLAY AREA POSITION TOLERANCE: H=80µm K=100µm
 2. DISPLAY AREA POSITION TOLERANCE: H=80µm K=100µm
 3. SIDE VIEW TANGLE RATIO: MAX. IS 50µm/cm.

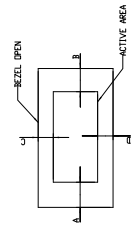

REV	A
DATE	2014-08-18
APPROVED BY	WANG YUAN
DESIGNED BY	WANG YUAN
DRAWN BY	WANG YUAN
CHECKED BY	WANG YUAN
DATE	2014-08-18
APPROVED BY	WANG YUAN
DESIGNED BY	WANG YUAN
DRAWN BY	WANG YUAN
CHECKED BY	WANG YUAN

ALL UNITS EXCEPT SPECIFIC NOTED OTHERWISE ARE IN MILLIMETER

Description	Date	Change By	Approved By	ECN No.	Remark

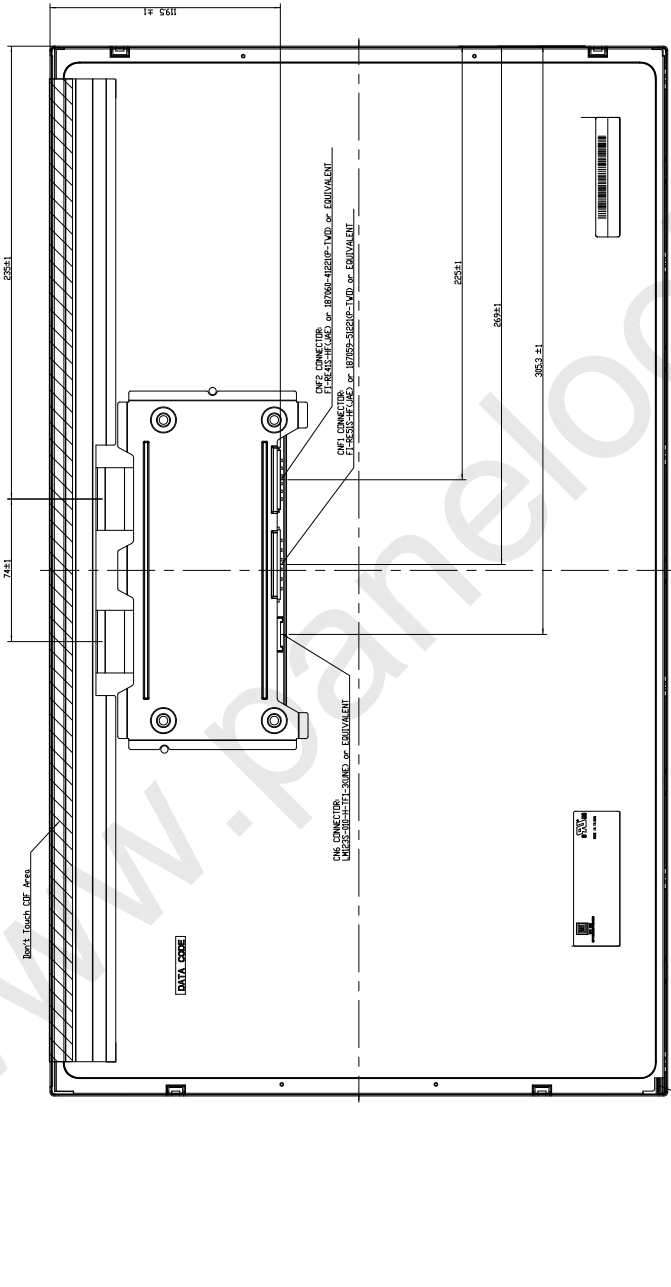

NOTE:
 1. DISPLAY AREA POSITION TOLERANCE: M-R:±0mm & L-C:±0.5mm
 2. UNINSPECTED TOLERANCE: ±0.2mm
 3. THIS DRAWING IS THE PROPERTY OF PANELLOOK. TRADE MARK: MAX. IS. Supp-con.

TITLE	DATE	NO.	REV.	A
1195	11/23	1		
Approved	By: [Signature]	Checked	By: [Signature]	
Drawn	By: [Signature]	Checked	By: [Signature]	
Design	By: [Signature]	Checked	By: [Signature]	

Description	Date	Changed By	Approved By	Ech. No.	Remark