

Doc. Number :

- Tentative Specification
- Preliminary Specification
- Approval Specification

**MODEL NO.: M236HJJ**  
**SUFFIX: P02**

<b>Customer: Common Model</b>	
<b>APPROVED BY</b>	<b>SIGNATURE</b>
_____	_____
<b>Name / Title</b> _____	
<b>Note</b>	
<b>Product version</b> C1	
_____	
Please return 1 copy for your confirmation with your signature and comments.	

Approved By	Checked By	Prepared By
吳柏勳	張耀元	向芝芬

- CONTENTS -

<b>1. GENERAL DESCRIPTION</b> .....	<b>5</b>
1.1 OVERVIEW.....	5
1.2 GENERAL SPECIFICATIONS .....	5
<b>2. MECHANICAL SPECIFICATIONS</b> .....	<b>5</b>
<b>3. ABSOLUTE MAXIMUM RATINGS</b> .....	<b>5</b>
3.1 ABSOLUTE RATINGS OF ENVIRONMENT .....	5
3.2 ELECTRICAL ABSOLUTE RATINGS .....	6
3.2.1 TFT LCD OPEN CELL.....	6
3.3 ABSOLUTE RATINGS OF ENVIRONMENT (OPEN CELL).....	6
<b>4. ELECTRICAL SPECIFICATIONS</b> .....	<b>7</b>
4.1 FUNCTION BLOCK DIAGRAM.....	7
4.2 INTERFACE CONNECTIONS .....	7
4.3 ELECTRICAL CHARACTERISTICS .....	8
4.3.1 LCD ELETRONICS SPECIFICATION .....	8
4.4 LVDS INPUT SIGNAL SPECIFICATIONS.....	11
4.4.1 LVDS DATA MAPPING TABLE .....	11
4.4.2 COLOR DATA INPUT ASSIGNMENT .....	11
4.5 DISPLAY TIMING SPECIFICATIONS .....	12
4.6 POWER ON/OFF SEQUENCE.....	14
<b>5. OPTICAL CHARACTERISTICS</b> .....	<b>15</b>
5.1 TEST CONDITIONS .....	15
5.2 OPTICAL SPECIFICATIONS .....	15
<b>6. RELIABILITY TEST ITEM</b> .....	<b>19</b>
<b>7. LABEL</b> .....	<b>19</b>
7.1 INX OPEN CELL LABEL.....	19
<b>8. PACKING</b> .....	<b>20</b>
8.1 PACKING SPECIFICATIONS .....	20
8.2 PACKING METHOD.....	20
8.3 PALLET.....	21
8.4 UN-PACKAGING METHOD .....	21
<b>9. PRECAUTION</b> .....	<b>22</b>
9.1 ASSEMBLY AND HANDLING PRECAUTIONS.....	22
9.2 STORAGE PRECAUTIONS.....	22
9.3 OPERATION PRECAUTIONS .....	22
9.4 SAFETY PRECAUTIONS .....	23
9.5 SAFETY STANDARDS .....	23
9.6 OTHER .....	23

Appendix. OUTLINE DRAWING .....23

液晶倉庫  
www.gotolcd.com

**REVISION HISTORY**

Version	Date	Page	Description
3.0	13 May 2014		Approval Spec Ver.3.0.
3.1	13 May 2014		OPTICAL SPECIFICATIONS Response Time

液晶倉庫  
www.gotolcd.com

## 1. GENERAL DESCRIPTION

### 1.1 OVERVIEW

The M236HJJ-P02 is a 23.6" TFT Liquid Crystal Display cell with driver ICs and a 30-pins-2ch-LVDS circuit board. The product supports 1920 x 1080 Full HD mode and can display up to 16.7M colors. The backlight unit is not built in.

### 1.2 GENERAL SPECIFICATIONS

Item	Specification	Unit	Note
Screen Size	23.6 inch Diagonal	mm	
Driver Element	a-si TFT active matrix	-	-
Pixel Number	1920 x R.G.B. x 1080	pixel	-
Pixel Pitch	0.2715(H) x 0.2715(V)	mm	-
Pixel Arrangement	RGB vertical stripe	-	-
Display Colors	16.7M	color	-
Transmissive Mode	Normally Black	-	-
Surface Treatment	AG type, 3H hard coating, Haze : 3.0 ±1.0%	-	-
Power Consumption	Total cell: 7 W(Typ.)		(1)

## 2. MECHANICAL SPECIFICATIONS

Item	Min.	Typ.	Max.	Unit	Note
Weight	-			g	
I/F connector mounting position	The mounting inclination of the connector makes the screen center within ±0.5mm as the horizontal.				(2)

Note (1) Please refer to the attached drawings for more information of front and back outline dimensions.

(2) Connector mounting position

(3) Please refer to sec.3.1 for more information of power consumption.

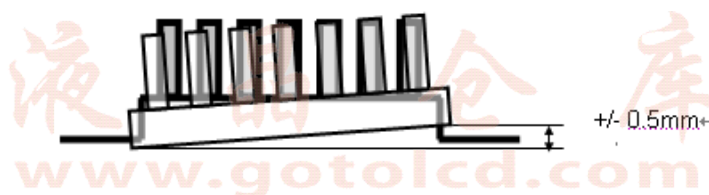

## 3. ABSOLUTE MAXIMUM RATINGS

### 3.1 ABSOLUTE RATINGS OF ENVIRONMENT

Item	Symbol	Value		Unit	Note
		Min.	Max.		
Storage Temperature	TST	-20	60	°C	(1)
Operating Ambient Temperature	TOP	0	50	°C	(1), (2)

Note (1)

(a) 90 %RH Max. (Ta < 40 °C).

(b) Wet-bulb temperature should be 39 °C Max. (Ta < 40 °C).

(c) No condensation.

Note (2) The temperature of panel surface should be 0 °C min. and 60 °C max.

Panel surface temperature should be 0°C min. and 65°C max under Vcc=12.0V, Input fr =60Hz, typical LED string current, 25°C ambient temperature, and no humidity control. Any condition of ambient operating temperature, the surface of active area should be keeping not higher than 65°C.

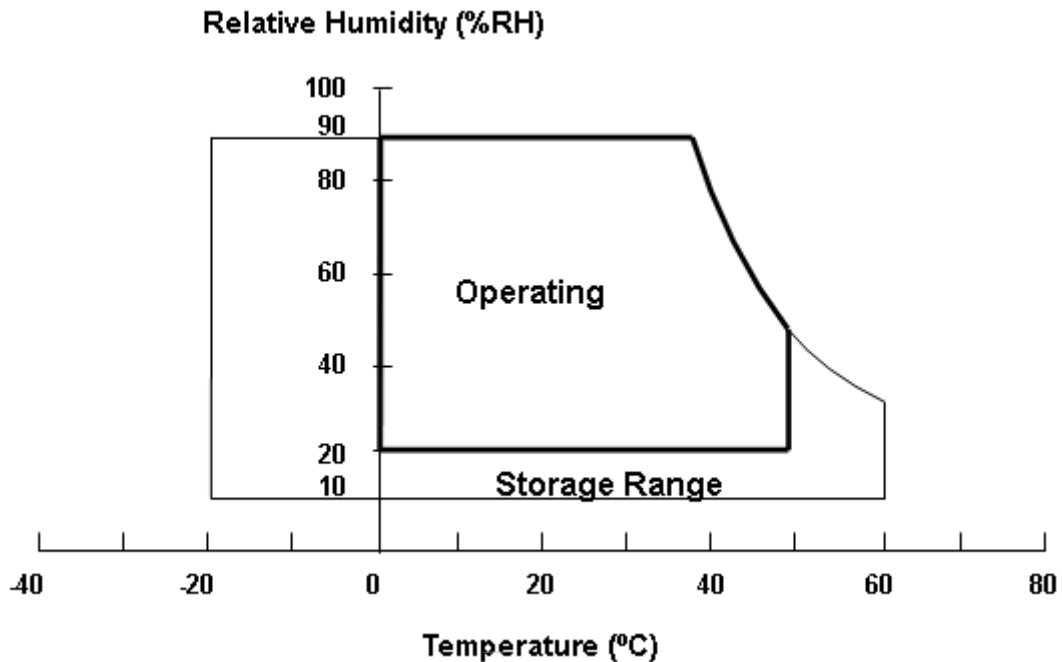

### 3.2 ELECTRICAL ABSOLUTE RATINGS

#### 3.2.1 TFT LCD OPEN CELL

Item	Symbol	Value		Unit	Note
		Min.	Max.		
Power Supply Voltage	VCCS	-0.3	6.0	V	(1)
Logic Input Voltage	V <sub>IN</sub>	-0.3	3.6	V	

Note (1) Permanent damage to the device may occur if maximum values are exceeded. Function operation should be restricted to the conditions described under Normal Operating Conditions.

### 3.3 ABSOLUTE RATINGS OF ENVIRONMENT (OPEN CELL)

High temperature or humidity may reduce the performance of panel. Please store LCD panel within the specified storage conditions.

Storage Condition: With packing.

Storage temperature range: 25±5 °C.

Storage humidity range: 50±10%RH.

Shelf life: 30days4. ELECTRICAL SPECIFICATIONS

## 4. ELECTRICAL SPECIFICATIONS

### 4.1 FUNCTION BLOCK DIAGRAM

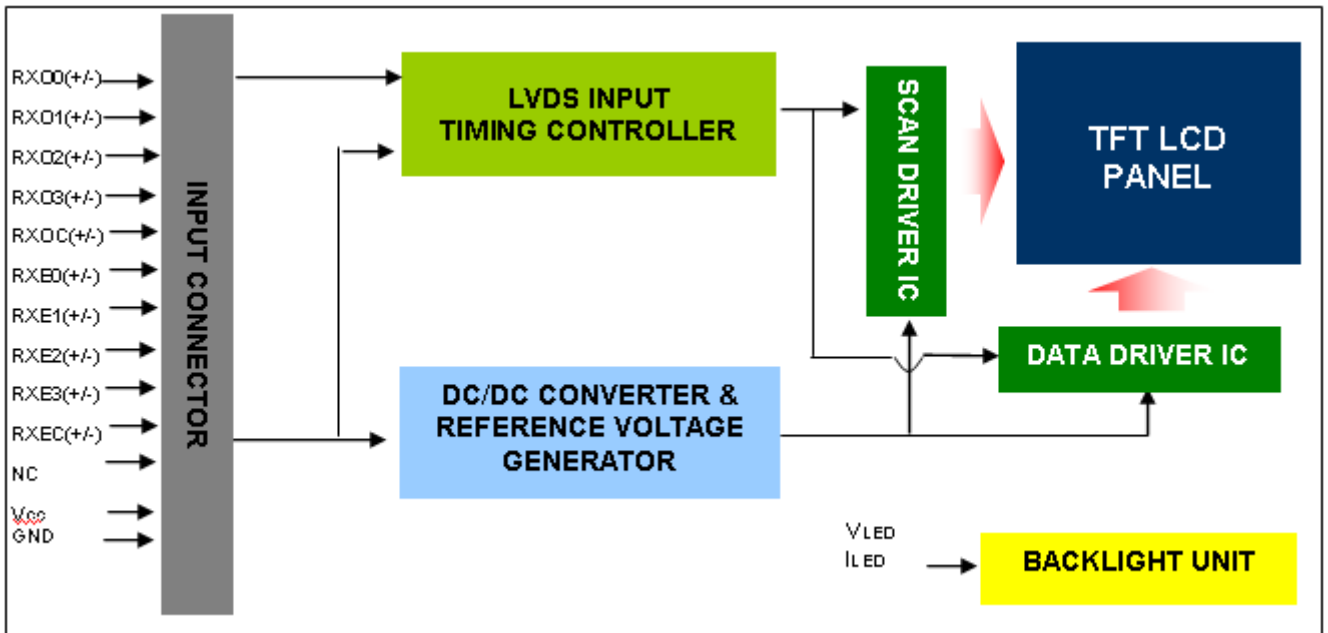

### 4.2 INTERFACE CONNECTIONS

#### PIN ASSIGNMENT

Pin	Name	Description
1	RXO0-	Negative LVDS differential data input. Channel O0 (odd)
2	RXO0+	Positive LVDS differential data input. Channel O0 (odd)
3	RXO1-	Negative LVDS differential data input. Channel O1 (odd)
4	RXO1+	Positive LVDS differential data input. Channel O1 (odd)
5	RXO2-	Negative LVDS differential data input. Channel O2 (odd)
6	RXO2+	Positive LVDS differential data input. Channel O2 (odd)
7	GND	Ground
8	RXOC-	Negative LVDS differential clock input. (odd)
9	RXOC+	Positive LVDS differential clock input. (odd)
10	RXO3-	Negative LVDS differential data input. Channel O3(odd)
11	RXO3+	Positive LVDS differential data input. Channel O3 (odd)
12	RXE0-	Negative LVDS differential data input. Channel E0 (even)
13	RXE0+	Positive LVDS differential data input. Channel E0 (even)
14	GND	Ground
15	RXE1-	Negative LVDS differential data input. Channel E1 (even)
16	RXE1+	Positive LVDS differential data input. Channel E1 (even)
17	GND	Ground
18	RXE2-	Negative LVDS differential data input. Channel E2 (even)
19	RXE2+	Positive LVDS differential data input. Channel E2 (even)
20	RXEC-	Negative LVDS differential clock input. (even)
21	RXEC+	Positive LVDS differential clock input. (even)
22	RXE3-	Negative LVDS differential data input. Channel E3 (even)
23	RXE3+	Positive LVDS differential data input. Channel E3 (even)
24	GND	Ground
25	NC	For LCD internal use only, Do not connect
Pin	Name	Description

26	SCL	I2C clock (for auto Vcom)
27	SDA	I2C data (for auto Vcom)
28	VCC	+5.0V power supply
29	VCC	+5.0V power supply
30	VCC	+5.0V power supply

Connector Information

Item	Description
Manufacturer	P-TWO/Foxconn
Type part number	P-TWO:187098-30091 Foxconn:GS23302-0321R-7H
User's Mating housing part number	FCN: FI-X30HL(JAE) P-TWO: SE 1220HS-D(JAE) Foxconn: FI-X30H(JAE)

\*Notice: There would be compatible issues if not using the indicated connectors in the matching list.

Note (1) The first pixel is odd.

Note (2) Input signal of even and odd clock should be the same timing.

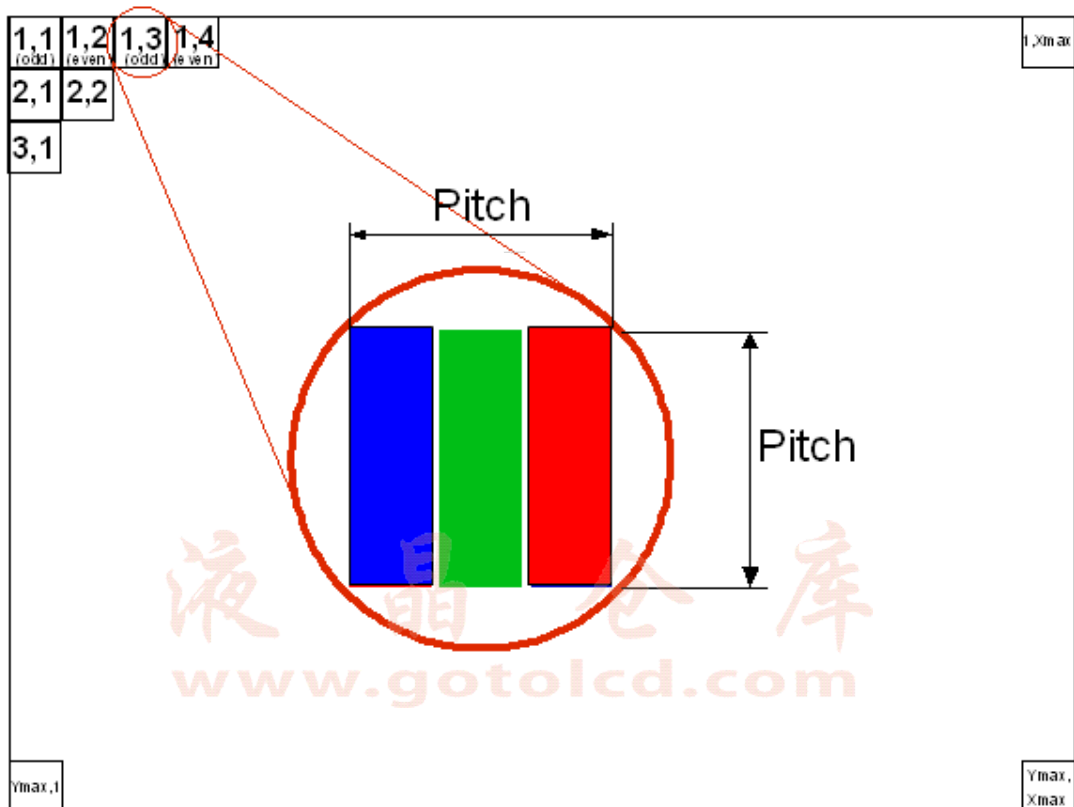

### 4.3 ELECTRICAL CHARACTERISTICS

#### 4.3.1 LCD ELETRONICS SPECIFICATION

Parameter	Symbol	Value			Unit	Note
		Min.	Typ.	Max.		
Power Supply Voltage	V <sub>CC</sub>	4.5	5.0	5.5	V	-
Ripple Voltage	V <sub>RP</sub>			300	mV	-
Rush Current	I <sub>RUSH</sub>			3	A	(2)
Power Supply Current	White		1.18	1.4	A	(3)a



	Black			0.83	0.97	A	(3)b
	Vertical Stripe			1.18	1.4	A	(3)c
Power Consumption		PLCD		5.7	7	Watt	(4)
LVDS interface	Differential Input Voltage	$V_{ID}$	100	-	600	mV	
	Common Input Voltage	$V_{CM}$	1.0	1.2	1.4	V	
	Differential Input High Threshold Voltage	$V_{TH}$		-	0.1	V	
	Differential Input Low Threshold Voltage	$V_{TL}$	-0.1	-		V	

Note (1) The ambient temperature is  $T_a = 25 \pm 2 \text{ }^\circ\text{C}$ .

Note (2) Measurement Conditions:

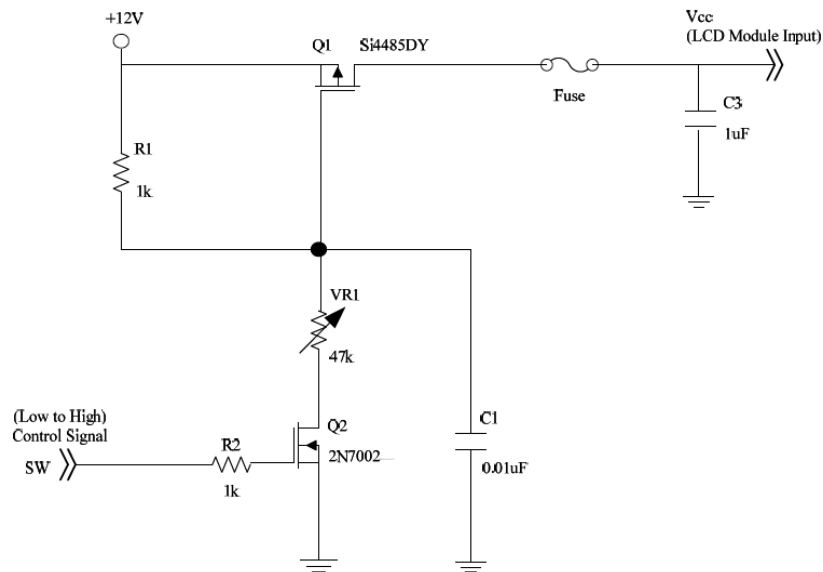

**Vcc rising time is 470μs**

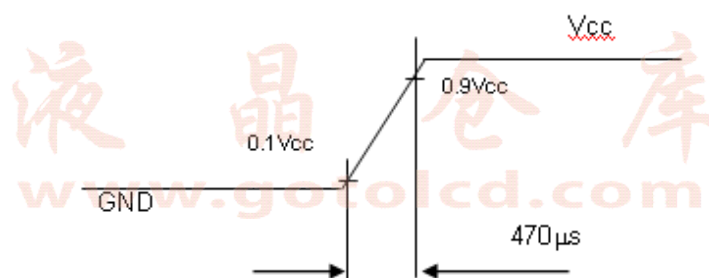

Note (3) The specified power supply current is under the conditions at  $V_{CC} = 12.0\text{ V}$ ,  $T_a = 25 \pm 2\text{ }^\circ\text{C}$ ,  $F_r = 75\text{ Hz}$ , whereas a power dissipation check pattern below is displayed.

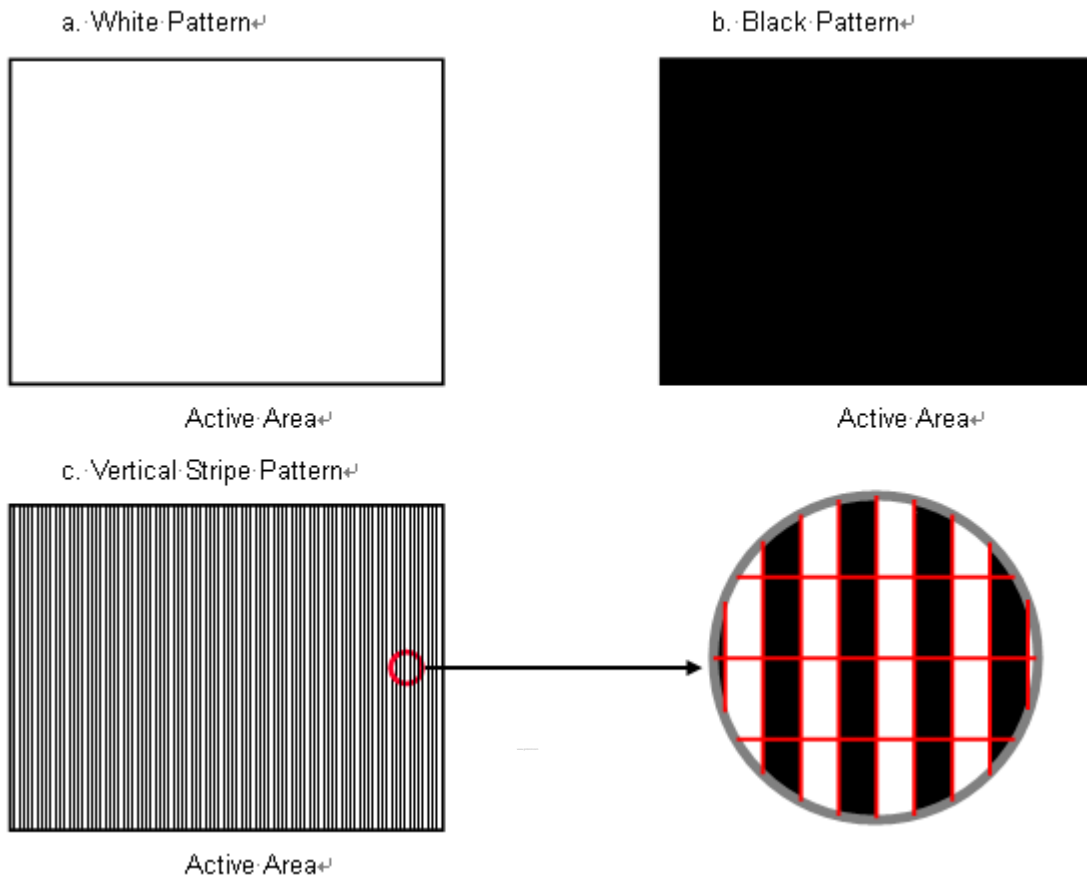

Note (4) The power consumption is specified at the pattern with the maximum current.

Note (5) The LVDS input characteristics are as follows:

**Single-end Signals**

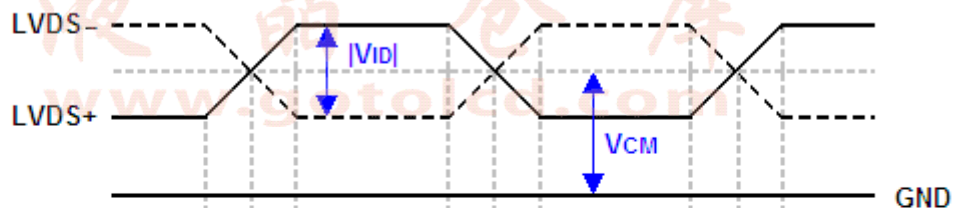

**Differential Signal**

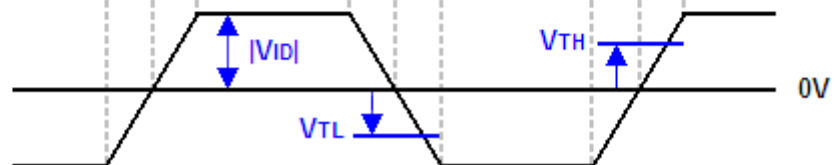

## 4.4 LVDS INPUT SIGNAL SPECIFICATIONS

### 4.4.1 LVDS DATA MAPPING TABLE

LVDS Channel O0	LVDS output	D7	D6	D4	D3	D2	D1	D0
	Data order	OG0	OR5	OR4	OR3	OR2	OR1	OR0
LVDS Channel O1	LVDS output	D18	D15	D14	D13	D12	D9	D8
	Data order	OB1	OB0	OG5	OG4	OG3	OG2	OG1
LVDS Channel O2	LVDS output	D26	D25	D24	D22	D21	D20	D19
	Data order	DE	NA	NA	OB5	OB4	OB3	OB2
LVDS Channel O3	LVDS output	D23	D17	D16	D11	D10	D5	D27
	Data order	NA	OB7	OB6	OG7	OG6	OR7	OR6
LVDS Channel E0	LVDS output	D7	D6	D4	D3	D2	D1	D0
	Data order	EG0	ER5	ER4	ER3	ER2	ER1	ER0
LVDS Channel E1	LVDS output	D18	D15	D14	D13	D12	D9	D8
	Data order	EB1	EB0	EG5	EG4	EG3	EG2	EG1
LVDS Channel E2	LVDS output	D26	D25	D24	D22	D21	D20	D19
	Data order	DE	NA	NA	EB5	EB4	EB3	EB2
LVDS Channel E3	LVDS output	D23	D17	D16	D11	D10	D5	D27
	Data order	NA	EB7	EB6	EG7	EG6	ER7	ER6

### 4.4.2 COLOR DATA INPUT ASSIGNMENT

The brightness of each primary color (red, green and blue) is based on the 8-bit gray scale data input for the color. The higher the binary input, the brighter the color. The table below provides the assignment of color versus data input.

Color		Data Signal																							
		Red								Green								Blue							
		R7	R6	R5	R4	R3	R2	R1	R0	G7	G6	G5	G4	G3	G2	G1	G0	B7	B6	B5	B4	B3	B2	B1	B0
Basic Colors	Black	0	0	0	0	0	0	0	0	0	0	0	0	0	0	0	0	0	0	0	0	0	0	0	0
	Red	1	1	1	1	1	1	1	1	0	0	0	0	0	0	0	0	0	0	0	0	0	0	0	0
	Green	0	0	0	0	0	0	0	0	1	1	1	1	1	1	1	1	0	0	0	0	0	0	0	0
	Blue	0	0	0	0	0	0	0	0	0	0	0	0	0	0	0	0	1	1	1	1	1	1	1	1
	Cyan	0	0	0	0	0	0	0	0	1	1	1	1	1	1	1	1	1	1	1	1	1	1	1	1
	Magenta	1	1	1	1	1	1	1	1	0	0	0	0	0	0	0	0	1	1	1	1	1	1	1	1
	Yellow	1	1	1	1	1	1	1	1	1	1	1	1	1	1	1	1	0	0	0	0	0	0	0	0
	White	1	1	1	1	1	1	1	1	1	1	1	1	1	1	1	1	1	1	1	1	1	1	1	1
Gray Scale Of Red	Red(0) / Dark	0	0	0	0	0	0	0	0	0	0	0	0	0	0	0	0	0	0	0	0	0	0	0	0
	Red(1)	0	0	0	0	0	0	0	1	0	0	0	0	0	0	0	0	0	0	0	0	0	0	0	0
	Red(2)	0	0	0	0	0	0	1	0	0	0	0	0	0	0	0	0	0	0	0	0	0	0	0	0
	⋮	⋮	⋮	⋮	⋮	⋮	⋮	⋮	⋮	⋮	⋮	⋮	⋮	⋮	⋮	⋮	⋮	⋮	⋮	⋮	⋮	⋮	⋮	⋮	⋮
	⋮	⋮	⋮	⋮	⋮	⋮	⋮	⋮	⋮	⋮	⋮	⋮	⋮	⋮	⋮	⋮	⋮	⋮	⋮	⋮	⋮	⋮	⋮	⋮	⋮
	Red(253)	1	1	1	1	1	1	0	1	0	0	0	0	0	0	0	0	0	0	0	0	0	0	0	0
	Red(254)	1	1	1	1	1	1	1	0	0	0	0	0	0	0	0	0	0	0	0	0	0	0	0	0
	Red(255)	1	1	1	1	1	1	1	1	0	0	0	0	0	0	0	0	0	0	0	0	0	0	0	0
Gray Scale Of Green	Green(0) / Dark	0	0	0	0	0	0	0	0	0	0	0	0	0	0	0	0	0	0	0	0	0	0	0	0
	Green(1)	0	0	0	0	0	0	0	0	0	0	0	0	0	0	1	0	0	0	0	0	0	0	0	0
	Green(2)	0	0	0	0	0	0	0	0	0	0	0	0	0	1	0	0	0	0	0	0	0	0	0	0
	⋮	⋮	⋮	⋮	⋮	⋮	⋮	⋮	⋮	⋮	⋮	⋮	⋮	⋮	⋮	⋮	⋮	⋮	⋮	⋮	⋮	⋮	⋮	⋮	⋮
	⋮	⋮	⋮	⋮	⋮	⋮	⋮	⋮	⋮	⋮	⋮	⋮	⋮	⋮	⋮	⋮	⋮	⋮	⋮	⋮	⋮	⋮	⋮	⋮	⋮
	Green(253)	0	0	0	0	0	0	0	0	1	1	1	1	1	1	0	1	0	0	0	0	0	0	0	0
	Green(254)	0	0	0	0	0	0	0	0	1	1	1	1	1	1	0	0	0	0	0	0	0	0	0	0
	Green(255)	0	0	0	0	0	0	0	0	1	1	1	1	1	1	1	0	0	0	0	0	0	0	0	0

Gray Scale Of Blue	Blue(0) / Dark	0	0	0	0	0	0	0	0	0	0	0	0	0	0	0	0	0	0	0	0	0	0	
	Blue(1)	0	0	0	0	0	0	0	0	0	0	0	0	0	0	0	0	0	0	0	0	0	1	
	Blue(2)	0	0	0	0	0	0	0	0	0	0	0	0	0	0	0	0	0	0	0	0	0	0	
	⋮	⋮	⋮	⋮	⋮	⋮	⋮	⋮	⋮	⋮	⋮	⋮	⋮	⋮	⋮	⋮	⋮	⋮	⋮	⋮	⋮	⋮		
	⋮	⋮	⋮	⋮	⋮	⋮	⋮	⋮	⋮	⋮	⋮	⋮	⋮	⋮	⋮	⋮	⋮	⋮	⋮	⋮	⋮	⋮		
	Blue(253)	0	0	0	0	0	0	0	0	0	0	0	0	0	0	0	0	1	1	1	1	1	0	1
	Blue(254)	0	0	0	0	0	0	0	0	0	0	0	0	0	0	0	0	1	1	1	1	1	1	0
	Blue(255)	0	0	0	0	0	0	0	0	0	0	0	0	0	0	0	0	1	1	1	1	1	1	1

Note (1) 0: Low Level Voltage, 1: High Level Voltage

#### 4.5 DISPLAY TIMING SPECIFICATIONS

The input signal timing specifications are shown as the following table and timing diagram.

Signal	Item	Symbol	Min.	Typ.	Max.	Unit	Note
LVDS Clock	Frequency	F <sub>c</sub>	58.54	74.25	(82.3)	MHz	-
	Period	T <sub>c</sub>		13.47		ns	
	Input cycle to cycle jitter	T <sub>rcj</sub>	-0.02*T <sub>c</sub>	-	0.02*T <sub>c</sub>	ns	(1)
	Input Clock to data skew	TLVCCS	-0.02*T <sub>c</sub>	-	0.02*T <sub>c</sub>	ps	(2)
	Spread spectrum modulation range	F <sub>ckin_mod</sub>	0.97*F <sub>c</sub>	-	1.03*F <sub>c</sub>	MHz	(3)
	Spread spectrum modulation frequency	F <sub>SSM</sub>	-	-	100	KHz	
Vertical Display Term	Frame Rate	Fr	50	60	63	Hz	T <sub>v</sub> =T <sub>v</sub> d+T <sub>v</sub> b
	Total	T <sub>v</sub>	1115	1125	1136	Th	-
	Active Display	T <sub>v</sub> d	1080	1080	1080	Th	-
	Blank	T <sub>v</sub> b	T <sub>v</sub> -T <sub>v</sub> d	T <sub>v</sub> -T <sub>v</sub> d	T <sub>v</sub> -T <sub>v</sub> d	Th	-
Horizontal Display Term	Total	T <sub>h</sub>	1050	1100	1150	T <sub>c</sub>	T <sub>h</sub> =T <sub>h</sub> d+T <sub>h</sub> b
	Active Display	T <sub>h</sub> d	960	960	960	T <sub>c</sub>	-
	Blank	T <sub>h</sub> b	T <sub>h</sub> -T <sub>h</sub> d	T <sub>h</sub> -T <sub>h</sub> d	T <sub>h</sub> -T <sub>h</sub> d	T <sub>c</sub>	-

Note: Because this module is operated by DE only mode, Hsync and Vsync input signals are ignored.

INPUT SIGNAL TIMING DIAGRAM

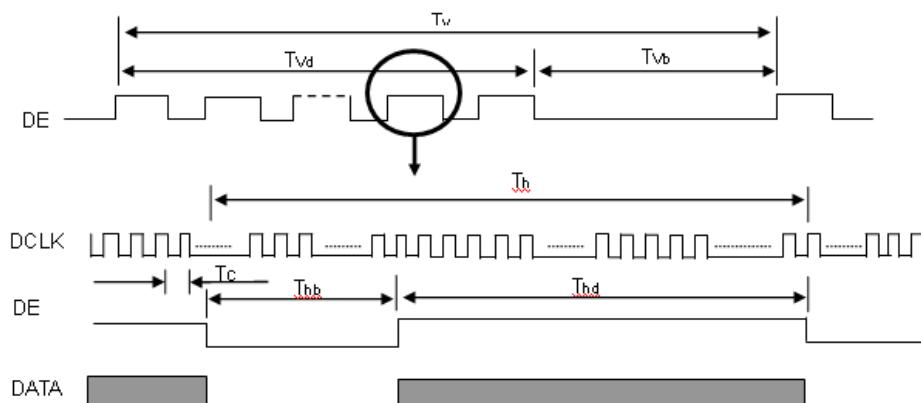

Note (1) The input clock cycle-to-cycle jitter is defined as below figures.  $Trcl = |T1 - T1'|$

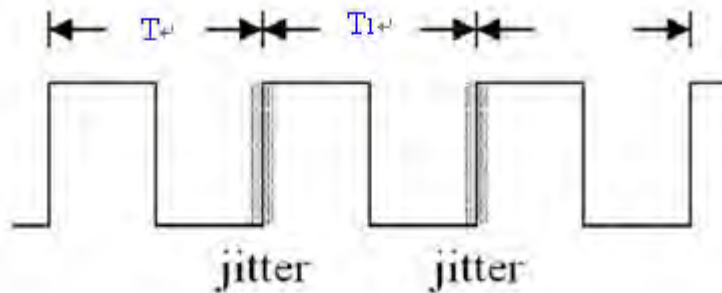

Note (2) Input Clock to data skew is defined as below figures.

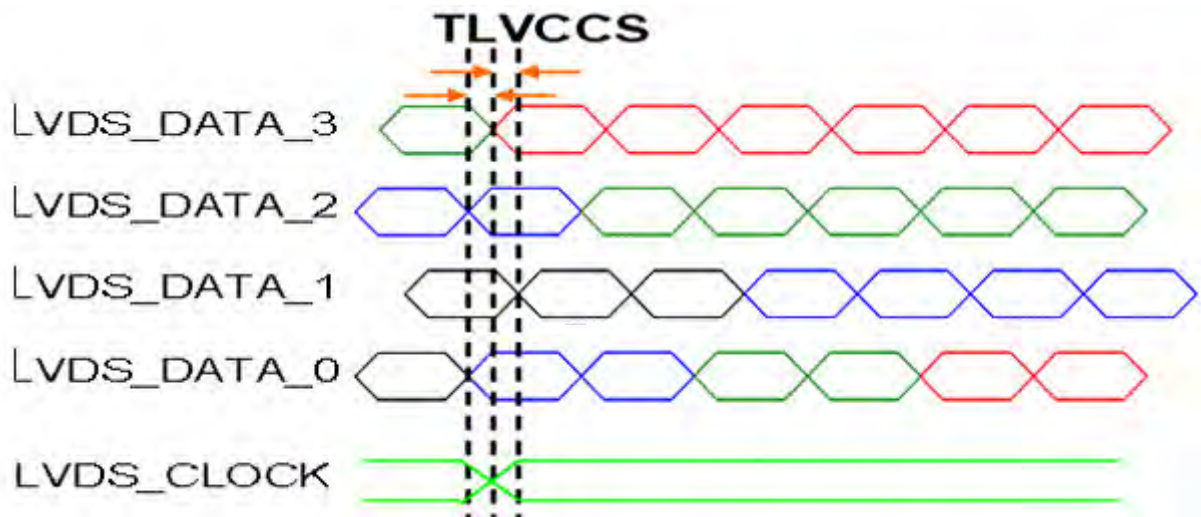

Note (3) The SSCG (Spread spectrum clock generator) is defined as below figures.

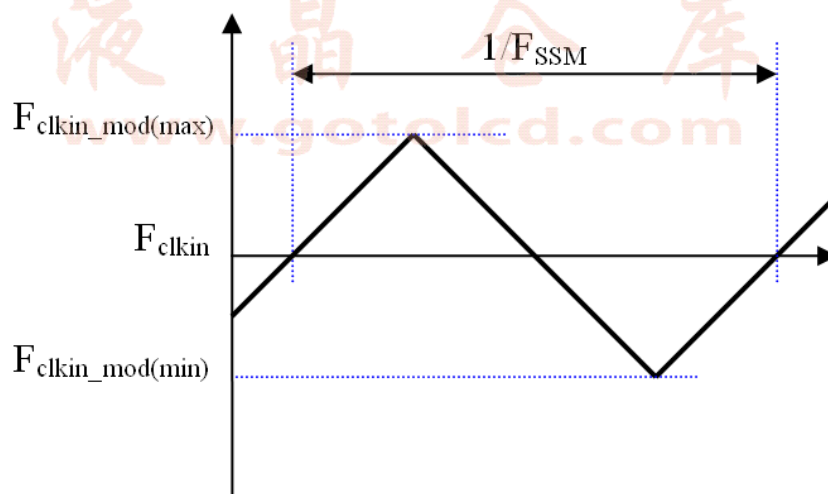

Note (4) The DCLK range at last line of V-blank should be set in 0 to Hdisplay/2

#### 4.6 POWER ON/OFF SEQUENCE

The power sequence specifications are shown as the following table and diagram.

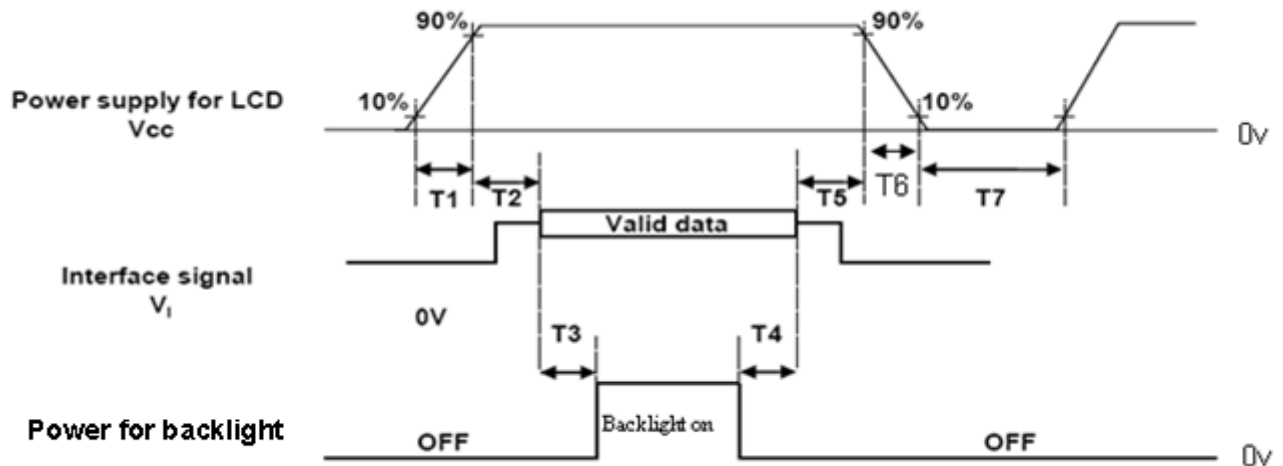

Timing Specifications:

Parameters	Values			Units
	Min	Typ.	Max	
T1	0.5	-	10	ms
T2	0	30	50	ms
T3	450	--	-	ms
T4	100	250	-	ms
T5	0	20	50	ms
T6	0.1	-	100	ms
T7	1000	-	-	ms

Note (1) The supply voltage of the external system for the module input should be the same as the definition of Vcc.

Note (2) When the backlight turns on before the LCD operation of the LCD turns off, the display may momentarily become abnormal screen.

Note (3) In case of VCC = off level, please keep the level of input signals on the low or keep a high impedance.

Note (4) T7 should be measured after the module has been fully discharged between power off and on period.

Note (5) Interface signal shall not be kept at high impedance when the power is on.

Note (6) INX won't take any responsibility for the products which are damaged by the customers not following the Power Sequence.

Note (7) There might be slight electronic noise when LCD is turned off (even backlight unit is also off). To avoid this symptom, we suggest "Vcc falling timing" to follow "t6 spec".

## 5. OPTICAL CHARACTERISTICS

### 5.1 TEST CONDITIONS

Item	Symbol	Value	Unit
Ambient Temperature	Ta	25±2	oC
Ambient Humidity	Ha	50±10	%RH
Supply Voltage	VCC	5	V
Input Signal	According to typical value in "3. ELECTRICAL CHARACTERISTICS"		
LED Light Bar Input Current Per Input Pin	IPIN	95	mA
PWM Duty Ratio	D	100	%
LED Light Bar Test Converter	INX R373B0000U00		

### 5.2 OPTICAL SPECIFICATIONS

The relative measurement methods of optical characteristics are shown in 5.2. The following items should be measured under the test conditions described in 5.1 and stable environment shown in Note (7).

Item	Symbol	Condition	Min.	Typ.	Max.	Unit	Note	
Color Chromaticity (CIE 1931)	Red	Rx	$\theta_x=0^\circ, \theta_y=0^\circ$ CS-2000 R=G=B=255 Gray scale	Typ - 0.03	Typ + 0.03	-	(1), (7)	
		Ry						
	Green	Gx						
		Gy						
	Blue	Bx						
		By						
	White	Wx						
		Wy						
Center Transmittance	T%		4.6		%	(1), (6)		
Contrast Ratio	CR		2000	3000	-	-	(1), (3)	
Response Time	Gray to Gray	$T_{G1G\_AVE}$	$\theta_x=0^\circ, \theta_y=0^\circ$	-	10	16	ms	(4-1), (4-2)
Viewing Angle	Horizontal	$\theta_{x-} + \theta_{x+}$	CR $\geq$ 10	160	178	-	Deg.	(1), (2)
Viewing Angle	Vertical	$\theta_{y-} + \theta_{y+}$		160	178	---		

液晶倉庫  
www.gotolcd.com

Note (1) Light source is the BLU (M236HJJ-L30), which is supplied by innolux, and driving voltages are based on suitable gamma voltages. W, R, G, B are with signal input. SPEC is judged by innolux's golden sample.

Note (2) Definition of Viewing Angle ( $\theta_x$ ,  $\theta_y$ ):

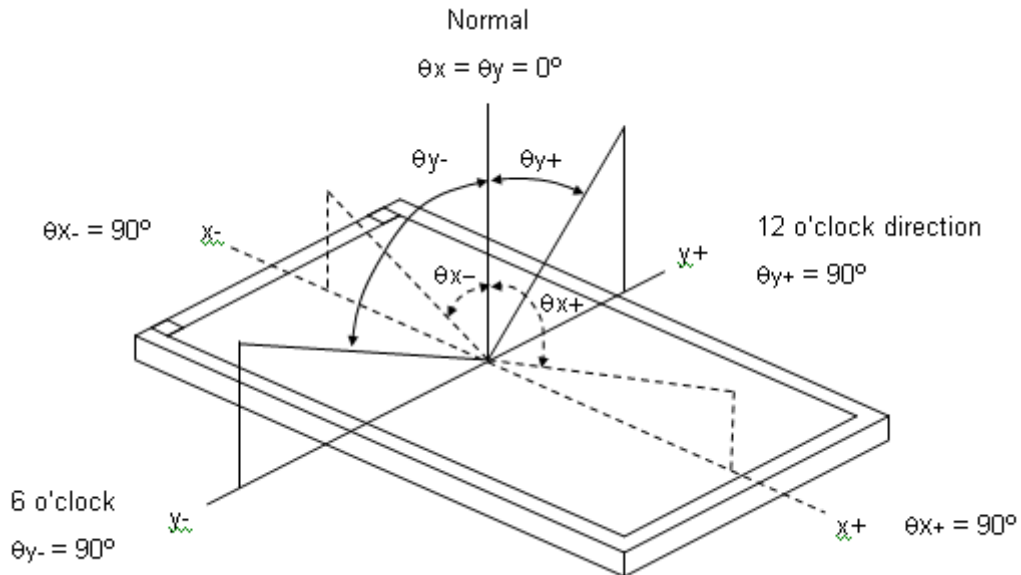

Note (3) Definition of Contrast Ratio (CR):

The contrast ratio can be calculated by the following expression.

$$\text{Contrast Ratio (CR)} = L_{255} / L_0$$

L255: Luminance of gray level 255

L 0: Luminance of gray level 0

$$\text{CR} = \text{CR} (5)$$

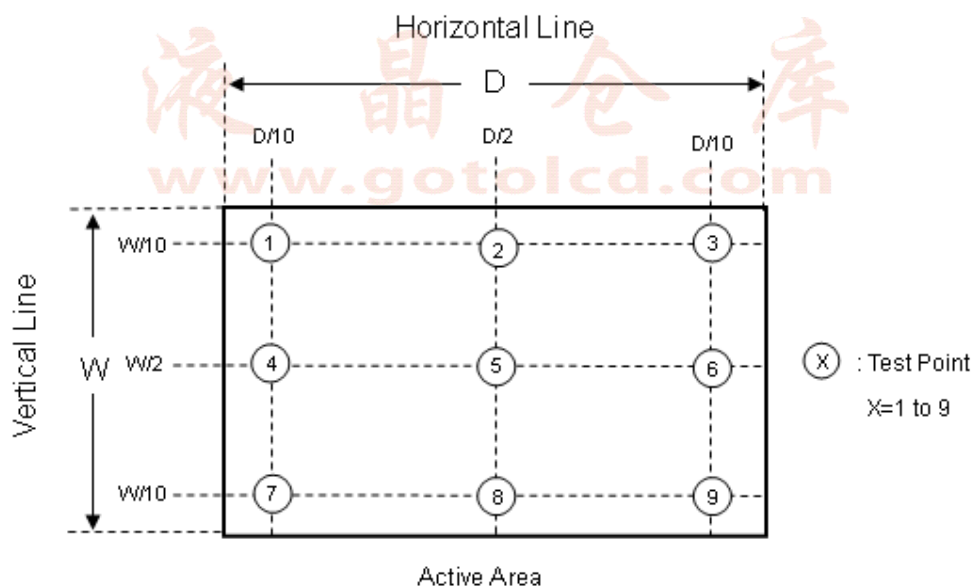

Note (4) Definition of Gray to Gray Response Time :



G to G(BW) Response time is defined as the following figure and shall be measured by switching the input signal for "Gray(N)" and "Black or White".

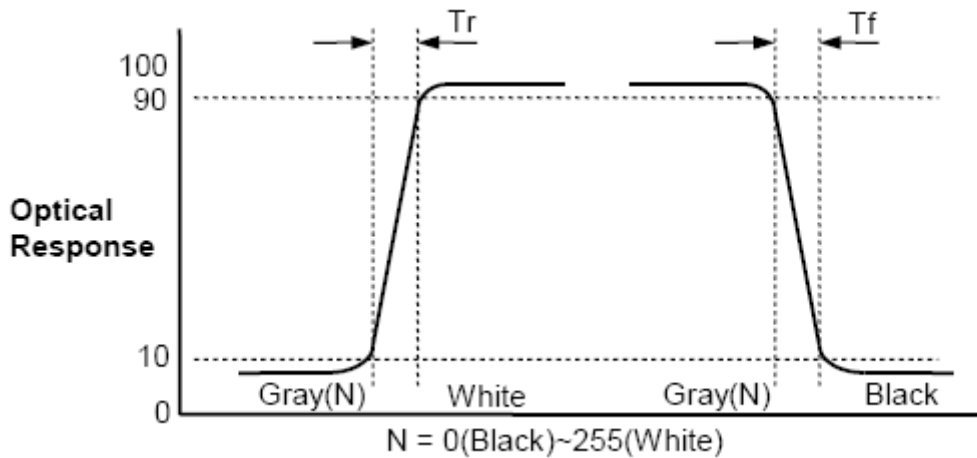

The Gray to Gray response time is defined as the following figure and shall be measured by switching the input signal for "Gray To Gray".

$T_{GIG\_AVE}$  is the total average time at rising time and falling time for "Gray To Gray".

- If system use ODC ( Over Driving Circuit) function,  $T_{GIG\_AVE}$  may be 5ms~8ms.

\* It depends on Overshoot rate.

Gray to Gray		Rising time								
		0	31	63	95	127	159	191	223	255
Falling time	0									
	31									
	63									
	95									
	127									
	159									
	191									
	223									
	255									

Note (5) Definition of Luminance of White ( $L_C$ ):

Measure the luminance of gray level 255 at center point

$$L_C = L(5)$$

$L(x)$  is corresponding to the luminance of the point X at Figure in Note (3).

Note (6) Definition of Transmittance (T%):

Module is with signal input.

$$\text{Transmittance} = \frac{\text{Luminance of LCD module } L(5)}{\text{Luminance of backlight}} * 100\%$$

$L(X)$  and  $L_{BLU}(X)$  is corresponding to the luminance of the point X at Figure in Note (3).

Note (7) Measurement Setup:

The LCD module should be stabilized at given temperature for 40 minutes to avoid abrupt temperature change during measuring. In order to stabilize the luminance, the measurement should be executed after lighting Backlight for 40 minutes in a windless room.

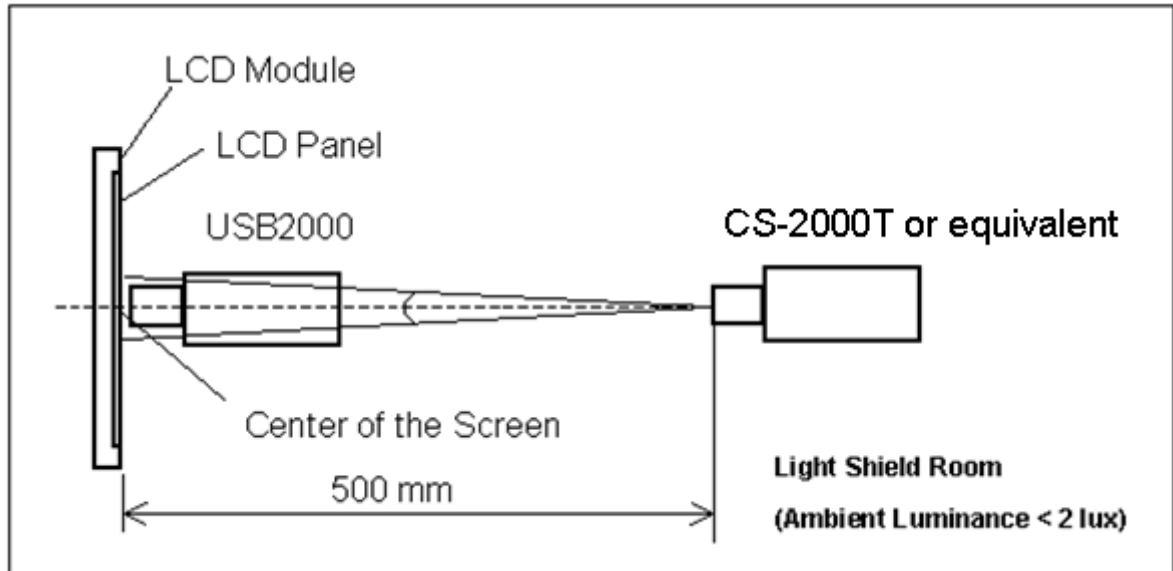

### 5.3 Flicker Adjustment

Flicker must be finely adjusted after module assembling and aging. Please follow the instructions below.

(1) Adjustment Pattern: 1+2line pattern as follows..

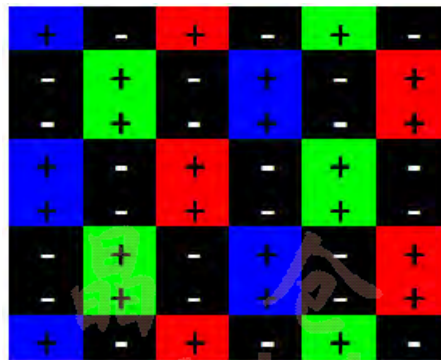

Note: Dark dots are gray level 0, and bright dots are gray level 128

(2) Adjustment Method:

Flicker should be adjusted by using the software of Auto-Vcom by the sensor. It is adjusted to the point with least flickering of the whole screen. After making it surely overrun at once, it should be adjusted to the optimum point.

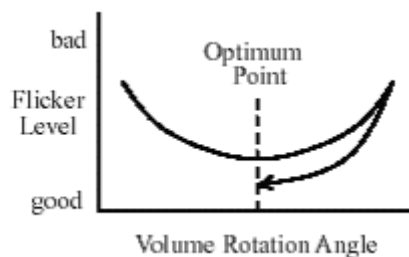

**6. RELIABILITY TEST ITEM**

Items	Required Condition	Note
Temperature Humidity Bias (THB)	Ta= 50°C, 80%RH, 240hours	(1)
High Temperature Operation (HTO)	Ta= 50°C, 50%RH, 240hours	
Low Temperature Operation (LTO)	Ta= 0°C, 240hours	
High Temperature Storage (HTS)	Ta= 60°C, 240hours	
Low Temperature Storage (LTS)	Ta= -20°C, 240hours	
Package Vibration Test	ISTA STANDARD 1.14Grms Random, Frequency Range: 1 ~ 200 Hz Top & Bottom: 30 minutes (+Z), 10 min (-Z), Right & Left: 10 minutes (X) Back & Forth 10 minutes (Y)	(2)
Thermal Shock Test (TST)	-20°C/30min, 60°C / 30min, 100 cycles	(1)
On/Off Test	25°C, On/10sec, Off /10sec, 30000 cycles	
Altitude Test	Operation: 10000 ft / 24hours Non-Operation: 30000 ft / 24hours	

Note (1) The tests are done with LCD modules (M280HKJ-L30).

Note (2) The test is done with a package shown in Section 8.

**7. LABEL**

**7.1 INX OPEN CELL LABEL**



Barcode definition:

Serial ID: CM-S0J02-X-X-X-XX-L-XX-L-YMD-NNNN

Code	Meaning	Description
CM	Supplier code	INX =CM
N6J03	Model number	M236HJJ-P02=N6J03
X	Revision code	C1:1, C2:2, ...
X	Source driver IC code	Century=1, CLL=2, Demos=3, Epson=4, Fujitsu=5, Himax=6, Hitachi=7, Hynix=8, LDI=9, Matsushita=A, NEC=B, Novatek=C, OKI=D, Philips=E, Renesas=F, Samsung=G, Sanyo=H, Sharp=I, TI=J, Topro=K, Toshiba=L, Windbond=M ILITEK=Q, Fiti=Y, None IC =Z
X	Gate driver IC code	
XX	Cell location	Tainan, Taiwan=TN Ningbo China=CN, Hsinchu Taiwan=SC
L	Cell line #	1,2,~,9,A,B,~,Y,Z
XX	Module location	Tainan, Taiwan=TN ; Ningbo China=NP, Shenzhen China=SH
L	Module line #	1,2,~,9,A,B,~,Y,Z
YMD	Year, month, day	Year: 2001=1, 2002=2, 2003=3, 2004=4...

		Month: 1~12=1, 2, 3, ~, 9, A, B, C Day: 1~31= 1, 2, 3, ~, 9, A, B, C, ~, T, U, V
NNNN	Serial number	Manufacturing sequence of product

**8. PACKING**

**8.1 PACKING SPECIFICATIONS**

- (1) 12 pcs lcd MNT Panels / 1 Box
- (2) Box dimensions : 630 (L) X 480 (W) X93 (H)mm
- (3) Weight : approximately 8.9Kg
- (4) 432 PCS lcd MNT Panels / 1 Group

**8.2 PACKING METHOD**

Packing method (Hard Box) is shown in following figures.

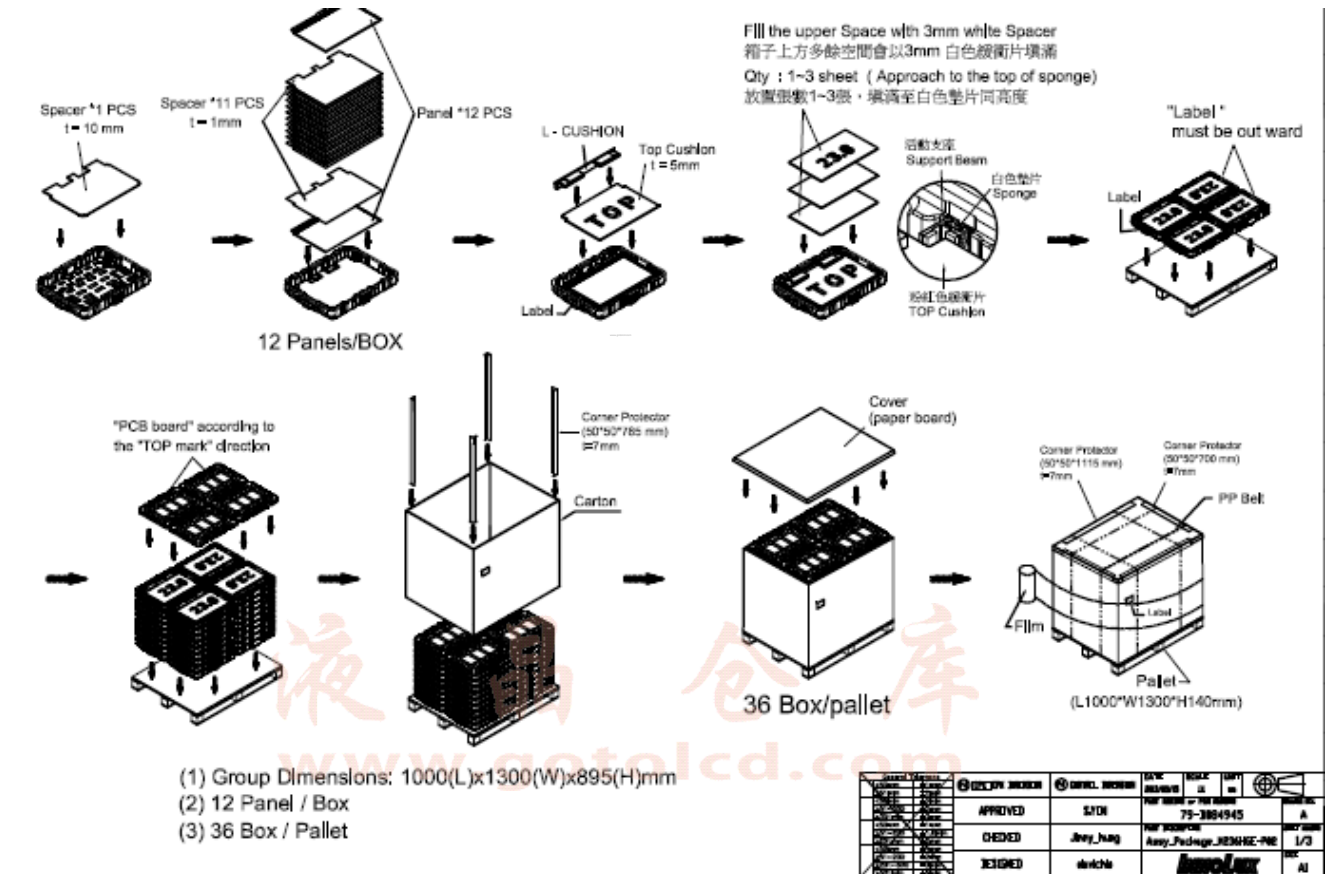
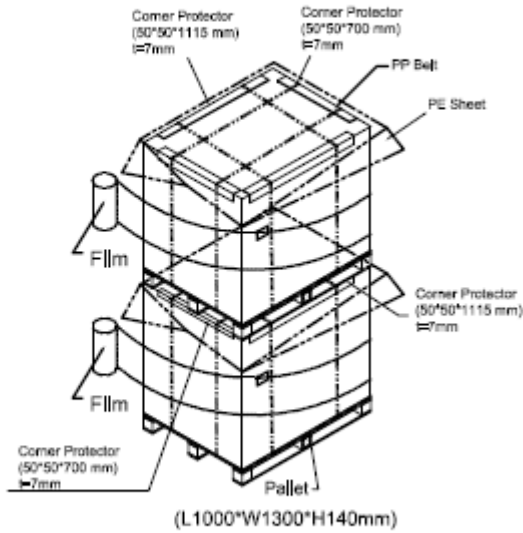

Figure.8-1 packing method

**8.3 PALLET**

**Sea / Land Transportation  
(40ft/40ft HQ Container)**



36 Box / Pallet +36 Box / Pallet

**Air Transportation**

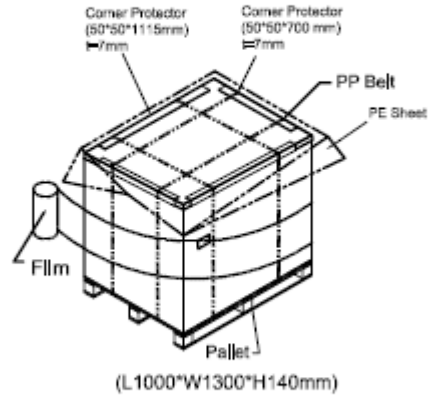

36 Box / Pallet

Figure.8-2 packing method

**8.4 UN-PACKAGING METHOD**

Un-packaging method (Hard Box) is shown in following figures.

**Unpacking Method**

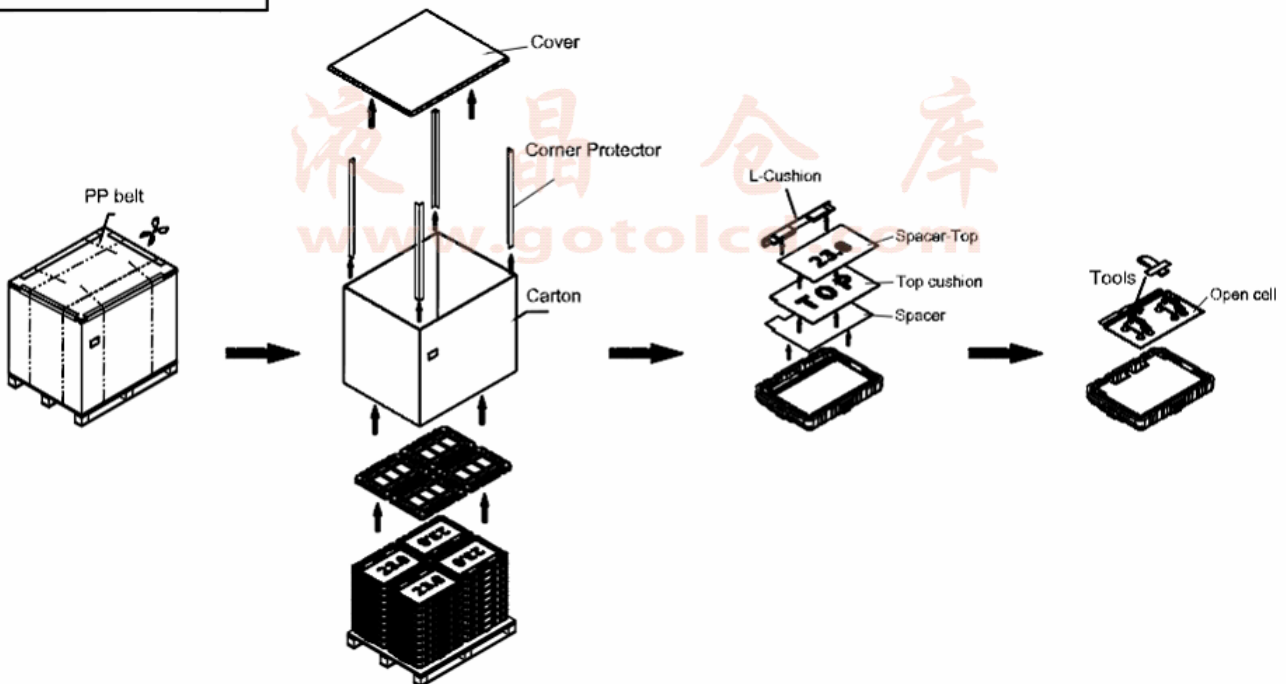

Figure.8-3 unpacking method

## 9. PRECAUTION

### 9.1 ASSEMBLY AND HANDLING PRECAUTIONS

- (1) Do not apply rough force such as bending or twisting to the module during assembly.
- (2) To assemble or install module into user's system can be only in clean working areas. The dust and oil may cause electrical short or worsen the polarizer.
- (3) It's not permitted to have pressure or impulse on the module because the LCD panel and Backlight will be damaged.
- (4) Always follow the correct power sequence when LCD module is connecting and operating. This can prevent damage to the CMOS LSI chips during latch-up.
- (5) Do not pull the I/F connector in or out while the module is operating.
- (6) Do not disassemble the module.
- (7) Use a soft dry cloth without chemicals for cleaning, because the surface of polarizer is very soft and easily scratched.
- (8) It is dangerous that moisture come into or contacted the LCD module, because moisture may damage LCD module when it is operating.
- (9) High temperature or humidity may reduce the performance of module. Please store LCD module within the specified storage conditions.
- (10) When ambient temperature is lower than 10°C may reduce the display quality. For example, the response time will become slowly.

### 9.2 STORAGE PRECAUTIONS

- (1) Do not leave the module in high temperature, and high humidity for a long time. It is highly recommended to store the module with temperature from 0°C to 35°C and relative humidity of less than 70%
- (2) Do not store the TFT – LCD module in direct sunlight
- (3) The module should be stored in dark place. It is prohibited to apply sunlight or fluorescent light in storing

### 9.3 OPERATION PRECAUTIONS

- (1) The LCD product should be operated under normal condition.  
Normal condition is defined as below :  
Temperature : 20±15°C  
Humidity: 65±20%  
Display pattern : continually changing pattern(Not stationary)
- (2) If the product will be used in extreme conditions such as high temperature, high humidity, high altitude ,display pattern or operation time etc...It is strongly recommended to contact INX for application engineering advice . Otherwise, its reliability and function may not be guaranteed.

#### 9.4 SAFETY PRECAUTIONS

- (1) If the liquid crystal material leaks from the panel, it should be kept away from the eyes or mouth. In case of contact with hands, skin or clothes, it has to be washed away thoroughly with soap.
- (2) After the module's end of life, it is not harmful in case of normal operation and storage.

#### 9.5 SAFETY STANDARDS

The LCD module should be certified with safety regulations as follows:

- (1) UL60950-1 or updated standard.
- (2) IEC60950-1 or updated standard.

#### 9.6 OTHER

When fixed patterns are displayed for a long time, remnant image is likely to occur.

#### Appendix. OUTLINE DRAWING

液晶倉庫  
www.gotolcd.com



REV	EC NUMBER	DESCRIPTION	DATE
△		First Release	2014/02/17

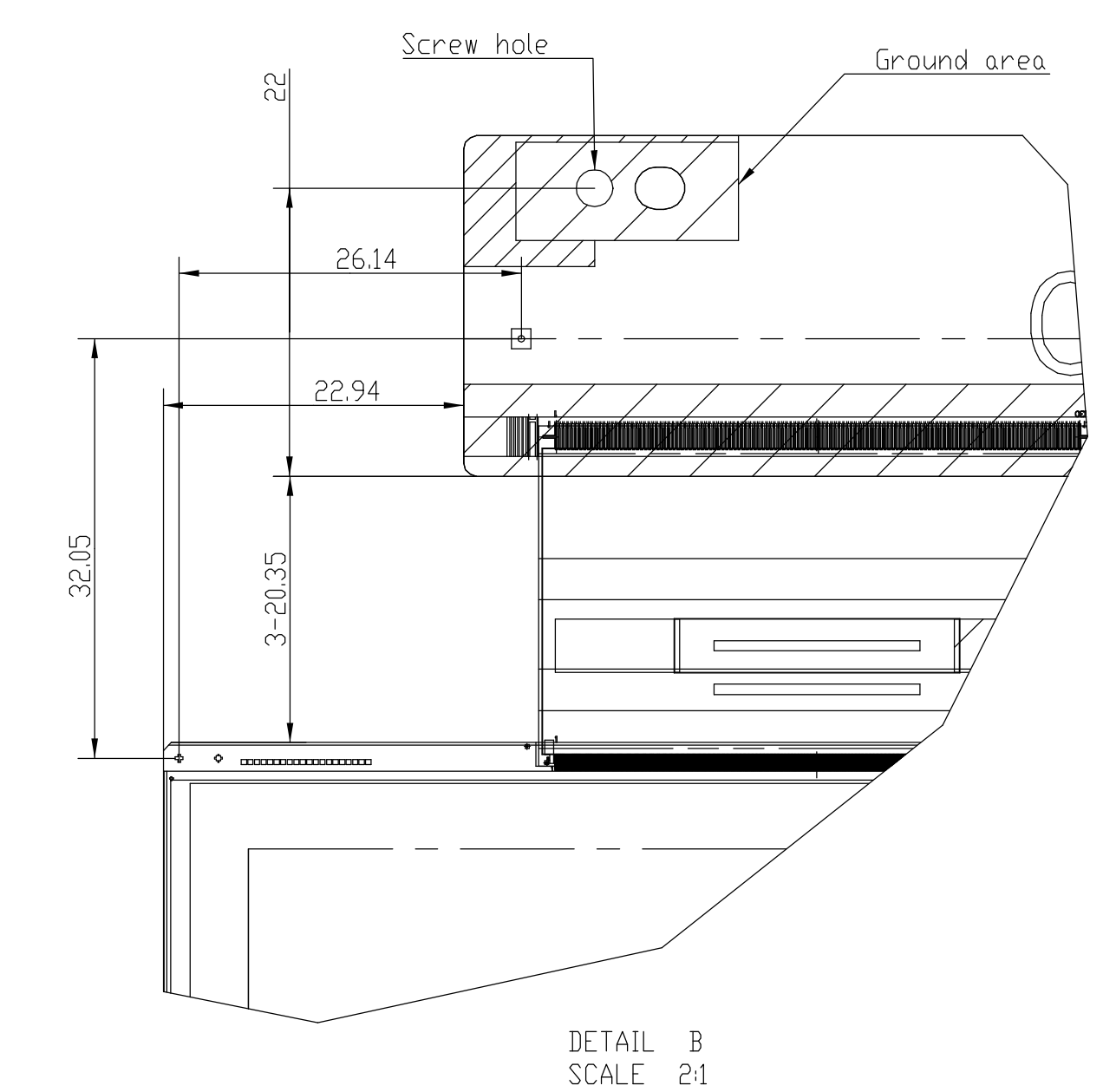
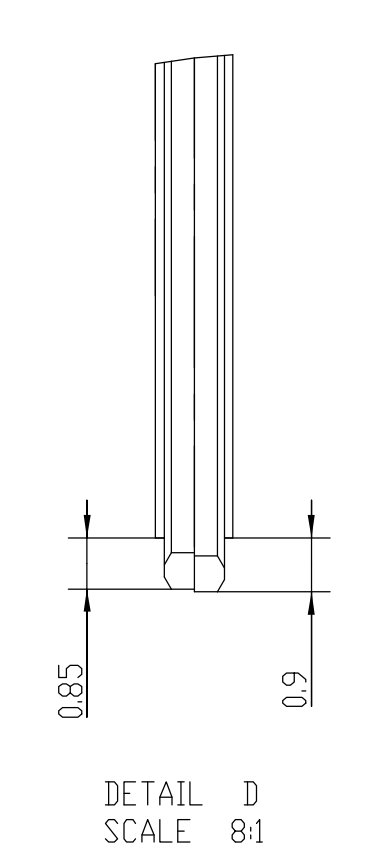
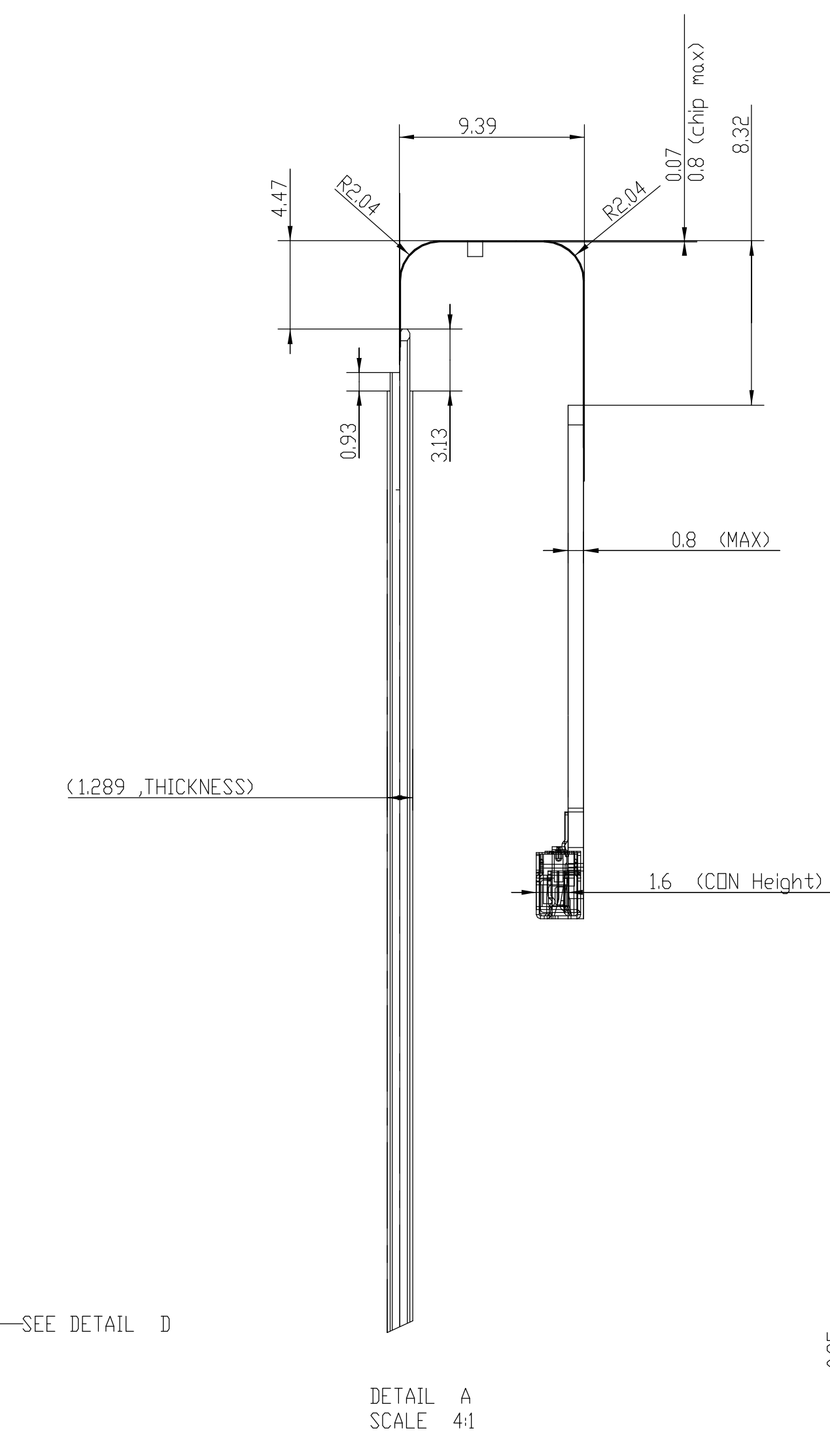
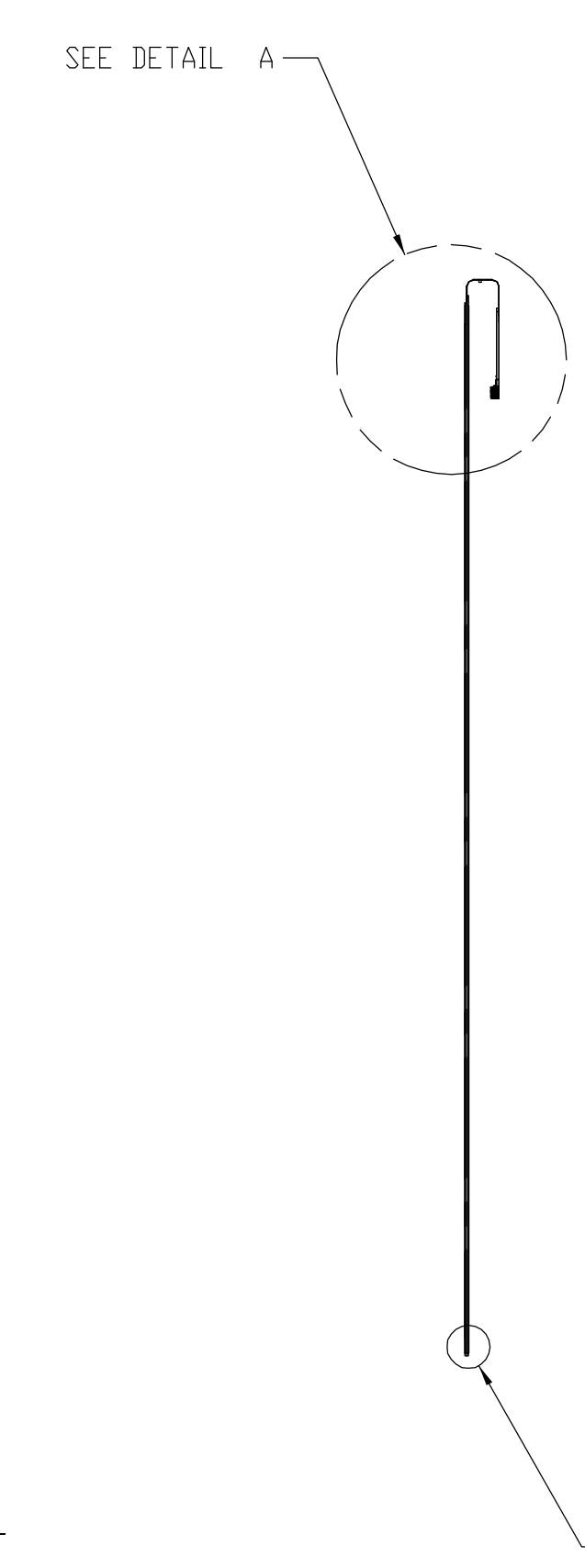
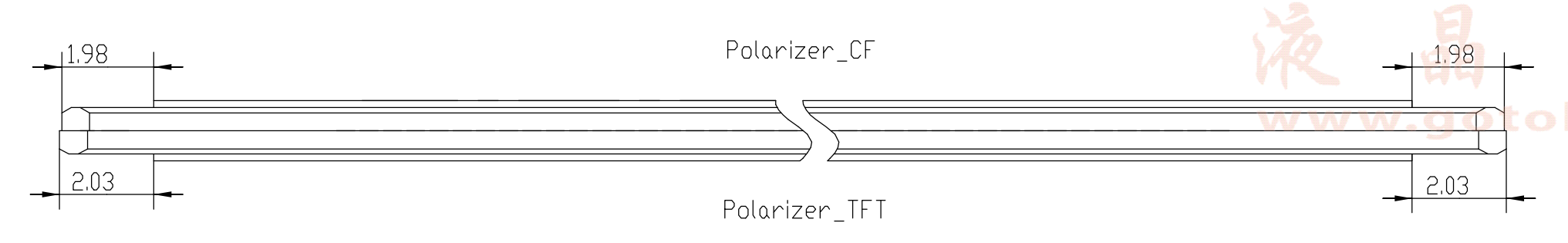
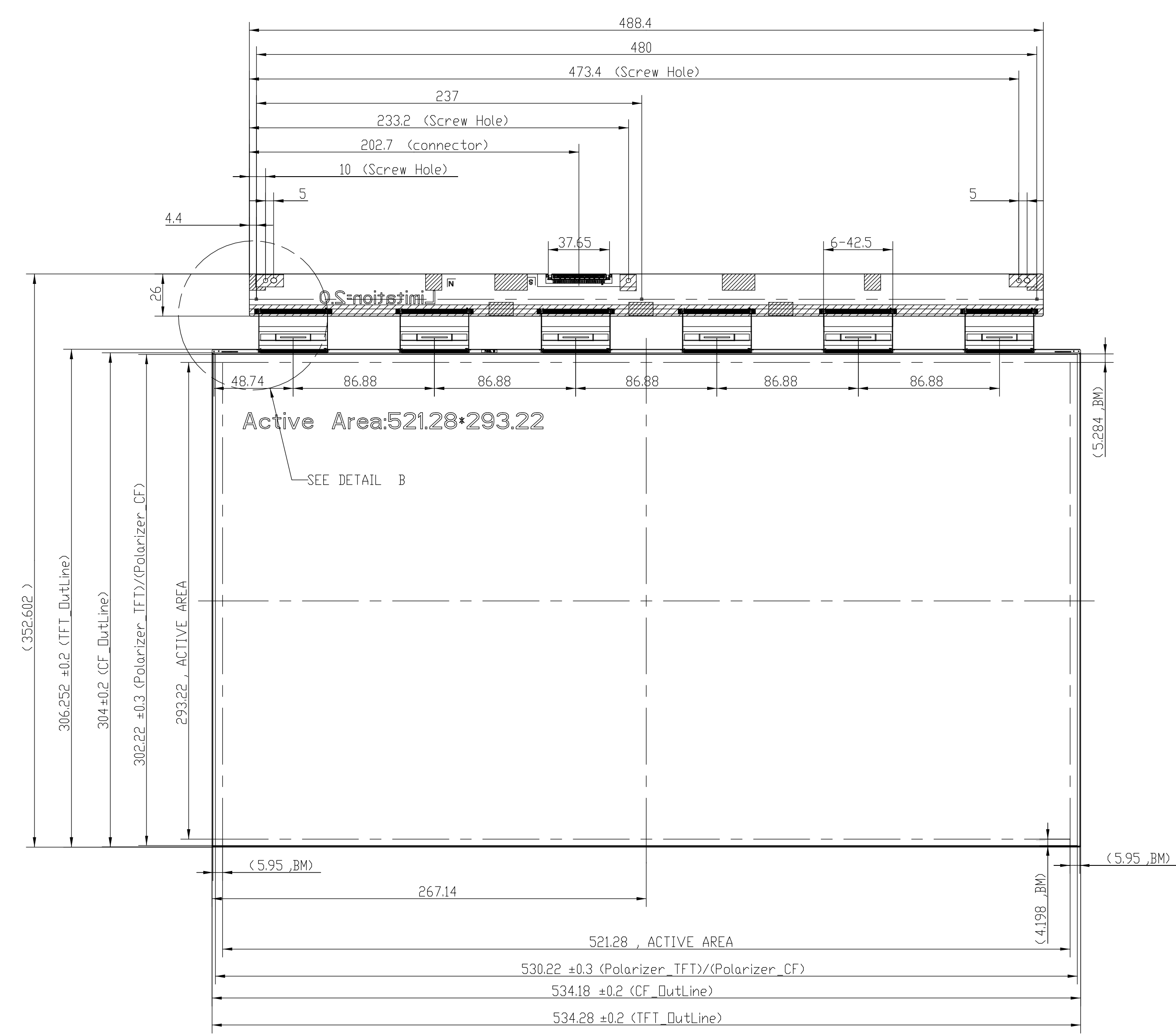

- NOTES:
1. \* NO COMPONENT AREA
  2. \* Cu AREA
  3. COMPONENT HEIGHT LIMITATION IS 2.35MM, UNLESS OTHERWISE INDECATED.
  4. LVDS INPUT CONNECTOR SPECIFICATION: P-TW0187114-30091 or Foxconn (GS23301-1321S-7H)
  5. THE DIAMETER OF SCREW HEAD MUST BE LESS 1MM (MIN) THAN GROUND PAD OUTLINE OF PCB'S SCREW HOLES.
  6. \* THE AREA CANNOT BE TOUCHED WITH CONDUCTIVE MATERIAL.

① CHECK DIMENSION	② CONTROL DIMENSION	DATE	SCALE	UNIT	④
APPROVED	YCLin	2014/02/17	1:1	mm	01
CHECKED	Jarvy.Hsu		XXXX		1/1
DESIGNED	Zowsung.Liang				AL