



InfoVision Optoelectronics (Kunshan) Co.,LTD.



Document Title	M236MWF1 Customer Approved Specification		Page No.	1/29
Document No.	A-M236MWF1-R2-12-02	Issue date	2010/1/29	Revision 00

Customer Approved Specification

To: 奥迪卡 (香港) 国际有限公司

Product Name: M236MWF1 R2

Document Issue Date:2010/1/29

Customer	InfoVision Optoelectronics
<u>SIGNATURE</u>	<u>SIGNATURE</u>
_____	QA
_____	 1/29/2010
_____	PREPARED BY
	FAE
	

Please return 1 copy for your confirmation with your signature and comments.

- Note: 1. Please contact IforVision Company. before designing your product based on this product.
 2. The information contained herein is presented merely to indicate the characteristics and performance of our products. No responsibility is assumed by IVO for any intellectual property claims or other problems that may result from application based on the module described herein.

FQ-7-30-0-009-03D



InfoVision Optoelectronics (Kunshan) Co.,LTD.

Document Title	M236MWF1 Customer Approved Specification			Page No.	3/29
Document No.	A-M236MWF1-R2-12-02	Issue date	2010/1/29	Revision	00

Contents

1	General Descriptions	p.4
2	Absolute Maximum Ratings	p.6
3	Pixel Format Image	p.7
4	Optical Characteristics	p.8
5	Backlight Characteristics.....	p.11
6	Electrical Characteristics	p.13
7	Interface Timings.....	p.20
8	Power Consumption	p.22
9	Power ON/OFF sequence	p.23
10	Mechanical Characteristic.....	p.24
11	Package Specification	p.25
12	Lot Mark.....	p.27
13	General Precaution	p.28



InfoVision Optoelectronics (Kunshan) Co.,LTD.

Document Title	M236MWF1 Customer Approved Specification			Page No.	4/29
Document No.	A-M236MWF1-R2-12-02	Issue date	2010/1/29	Revision	00

1.0 General Descriptions

1.1 Introduction

The **M236MWF1** is a color active matrix thin film transistor (TFT) liquid crystal display (LCD) that uses amorphous silicon TFT as a switching device. It is composed of a TFT LCD panel, a timing controller, voltage reference, common voltage, driver DC-DC converter, column driver, and row driver circuit. This TFT LCD has a 23-inch diagonally measured active display area with WXGA+ resolution (1920 vertical by 1080 horizontal pixel array).

1.2 Features

- 23.6" WXGA+ TFT LCD Panel
- 4 CCFLs Backlight System
- Supported WXGA+ (V:1920 lines, H:1080pixels) resolution
- Supported to 75Hz Refresh Rate
- Compatible with RoHS Standard
- Compatible with ACC function

1.3 Product Summary

Items	Specifications	Unit
Screen Diagonal	23.6	Inch
Active Area	521.28 (H) x 293.22 (V)	mm
Pixels H x V	1, 920(x3) x 1,080	
Pixel Pitch	0.2715 (per one triad) x 0.2715	mm
Pixel Arrangement	R.G.B. Vertical Stripe	
Display Mode	Normally White	
White Luminance	300 typical	cd/ m ² (CCFL@ 7.0mA)
Contrast Ratio	1,000 : 1 typical	
Color Saturation	72%	NTSC
Response Time	5 typical	msec
Input Voltage	+ 5.0 typical	V
Logic Power Consumption	4.5 typical (Black pattern, 60Hz)	Watt
Backlight Power Consumption	26.32 typical (CCFL current 7.0mA)	Watt
Weight	3,250typ	g
Outline Dimension	544.8(W) x 320.5(H) x 18.38(T) typical	mm
Electrical Interface (Logic)	8bit , dual LVDS	
Support Color	16.7M	
Luminance Uniformity	80% typical (@9 points)	
Optimum Viewing Direction	6 o'clock	
Surface Treatment	AG/3H	
Screw torque value	5max	Kgf-cm

Note:Lamp Life Time is 50,000h(Ta=25+/-3degC and ICCFL=7.0mA, brightness becomes lower than 50% of initial value)



InfoVision Optoelectronics (Kunshan) Co.,LTD.

Document Title	M236MWF1 Customer Approved Specification			Page No.	5/29
Document No.	A-M236MWF1-R2-12-02	Issue date	2010/1/29	Revision	00

1.4 Functional Block Diagram

Figure 1 shows the functional block diagram of the LCD module.

Figure 1 Block Diagram

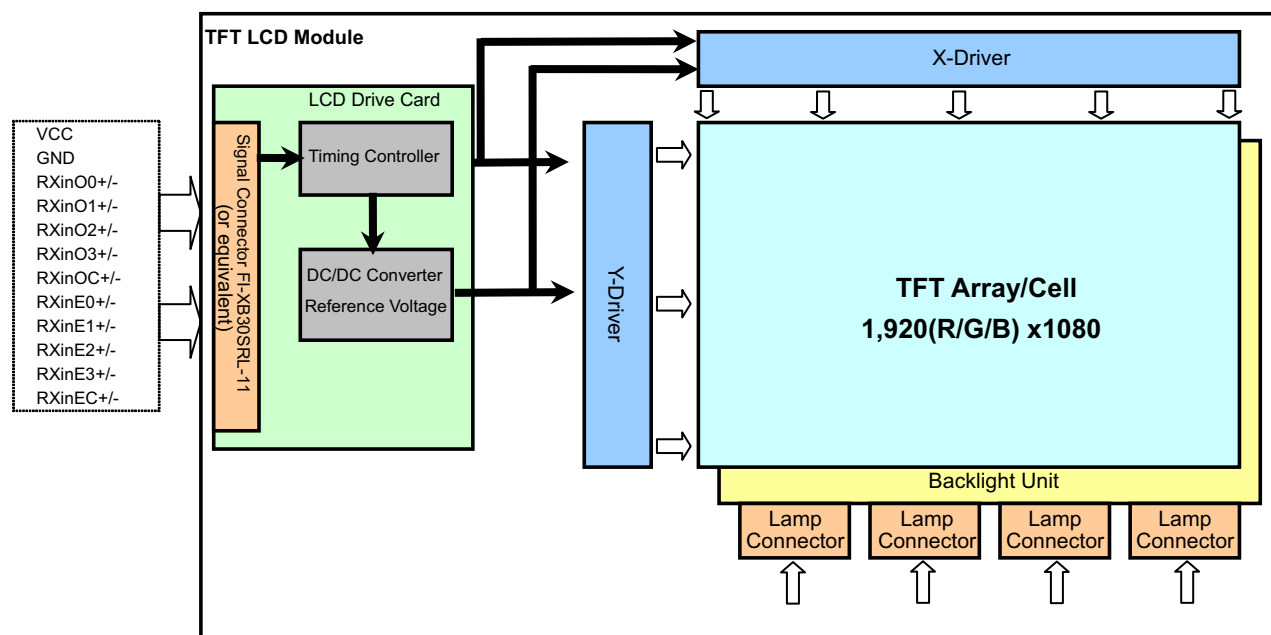



InfoVision Optoelectronics (Kunshan) Co.,LTD.

Document Title	M236MWF1 Customer Approved Specification			Page No.	6/29
Document No.	A-M236MWF1-R2-12-02	Issue date	2010/1/29	Revision	00

2.0 Absolute Maximum Ratings

Table 1

Item	Symbol	Min	Max	Unit	Conditions
Supply Voltage	VDD	-0.3	+6.0	V	--
Input Signal	--	-0.3	+2.7	V	LVDS signals
Operating Temperature	TOP	0	+50	Deg. C	(Note)
Operating Humidity	HOP	10	80	%RH	(Note)
Storage Temperature	TST	-20	+60	Deg. C	(Note)
Storage Humidity	HST	10	90	%RH	(Note)
Vibration	--	--	1.5 10-500-10	G Hz	30min for X, Y, Z axis
Shock	--	--	50 11	G ms	Half sign wave

Note: (1) Storage /Operating temperature. Maximum Wet-Bulb should be 39 degree C.
No condensation.

Figure 2

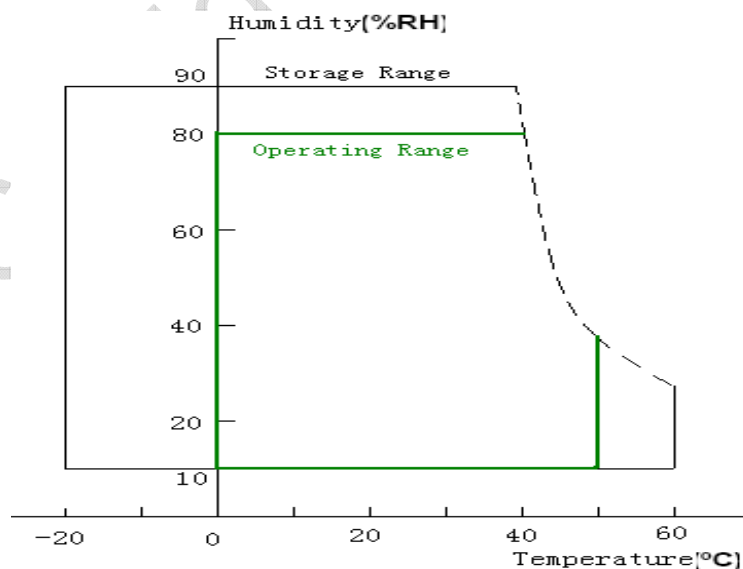



InfoVision Optoelectronics (Kunshan) Co.,LTD.

Document Title	M236MWF1 Customer Approved Specification			Page No.	7/29
Document No.	A-M236MWF1-R2-12-02	Issue date	2010/1/29	Revision	00

3.0 Pixel Format Image

Figure shows the relationship of the input signals and LCD pixel format image.

Figure 3 Pixel Format

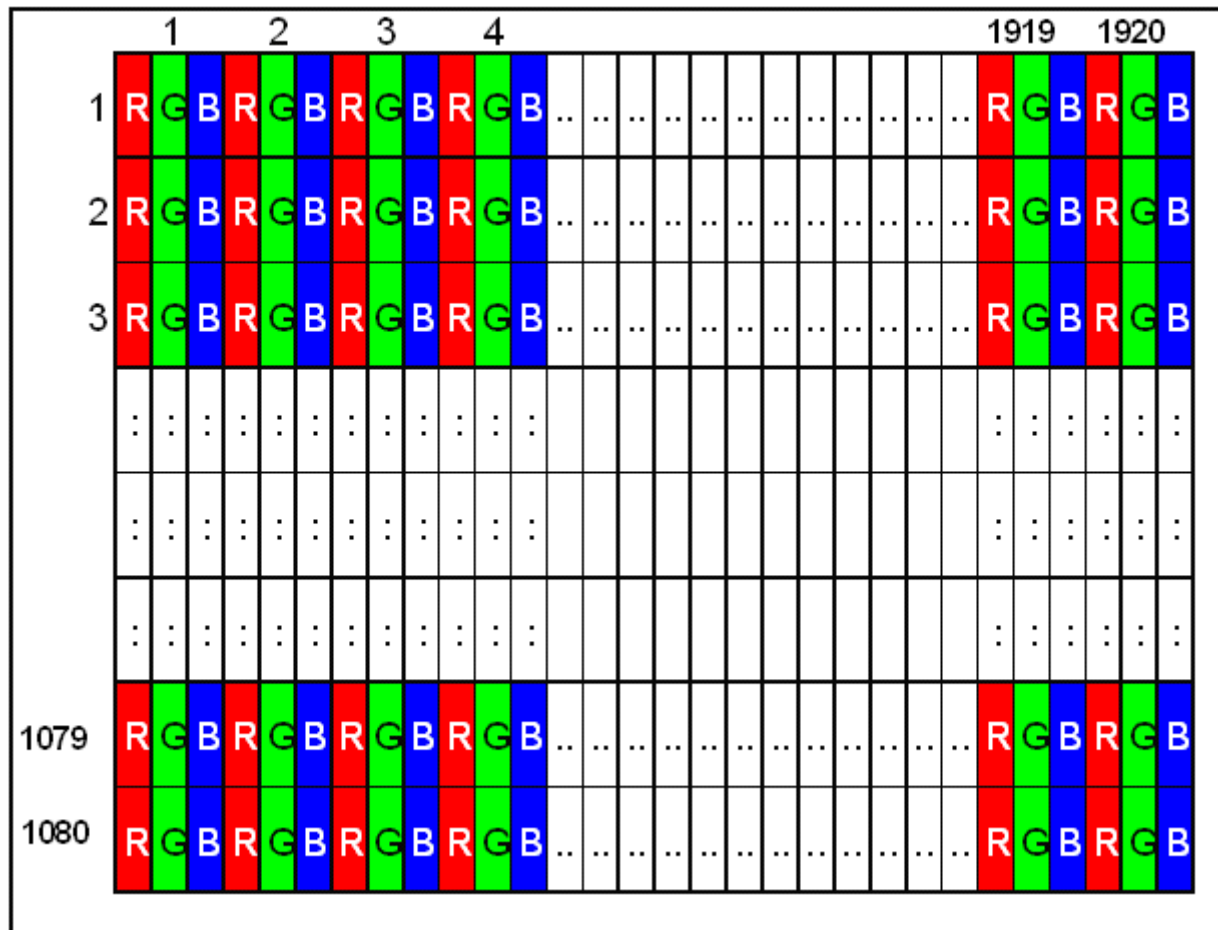



InfoVision Optoelectronics (Kunshan) Co.,LTD.

Document Title	M236MWF1 Customer Approved Specification			Page No.	8/29
Document No.	A-M236MWF1-R2-12-02	Issue date	2010/1/29	Revision	00

4.0 Optical Characteristics

The optical characteristics are measured under stable conditions as following notes

Table 2 Optical Characteristics

Item	Conditions	Specification			
		Min	Typ	Max	Note
Viewing Angle [degrees] K=Contrast Ratio>10	Horizontal	150	170	--	A, B
	Vertical	140	160	--	
Contrast ratio	Center	700	1000	--	A, C
Response Time [ms]	Rising + Falling	--	5	8	A, D
Color Chromaticity (CIE1931)	Red x	-0.03	0.642	+0.03	A,
	Red y		0.334		A,
	Green x		0.281		A,
	Green y		0.600		A,
	Blue x		0.144		A,
	Blue y		0.071		A,
	White x		0.313		A,
	White y		0.329		A,
White Luminance [cd/m ²]	ICCFL=7.0mA	250	300	--	Center A, E
Luminance Uniformity	ICCFL=7.0mA, 9points	75%	80%	--	A, F

Note:

A. Measurement Setup:

The LCD module should be stabilized at given temperature for 20 minutes to avoid abrupt temperature change during measuring. In order to stabilize the luminance, the measurement should be executed after lighting backlight for 20 minutes in a windless room.

Figure 4 Measurement Setup

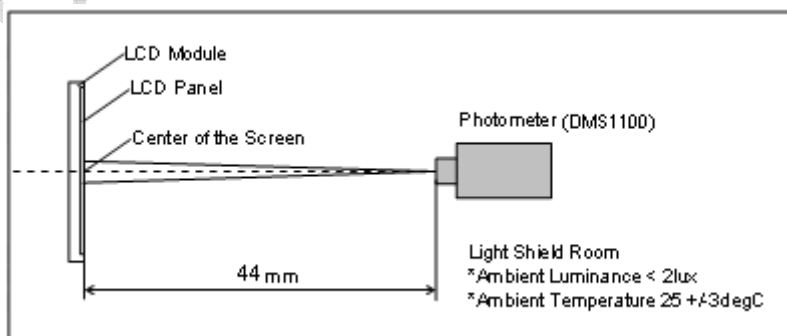

Document Title	M236MWF1 Customer Approved Specification			Page No.	9/29
Document No.	A-M236MWF1-R2-12-02	Issue date	2010/1/29	Revision	00

B. Definition of Viewing Angle

Figure 5 Definition of Viewing Angle

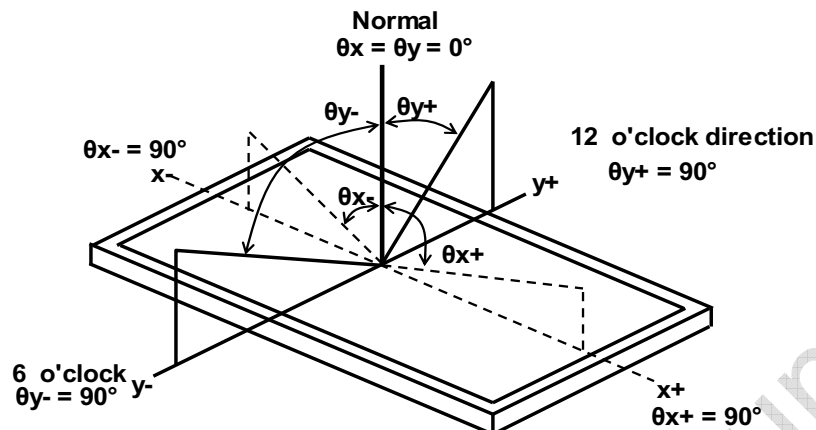

C. Definition of Contrast Ratio (CR)

The contrast ratio can be calculated by the following expression

$$\text{Contrast Ratio (CR)} = L_{255} / L_0$$

L₂₅₅: Luminance of gray level 255,

L₀: Luminance of gray level 0

D. Definition of Response Time (T_R, T_F)

Figure 6 Definition of Response Time

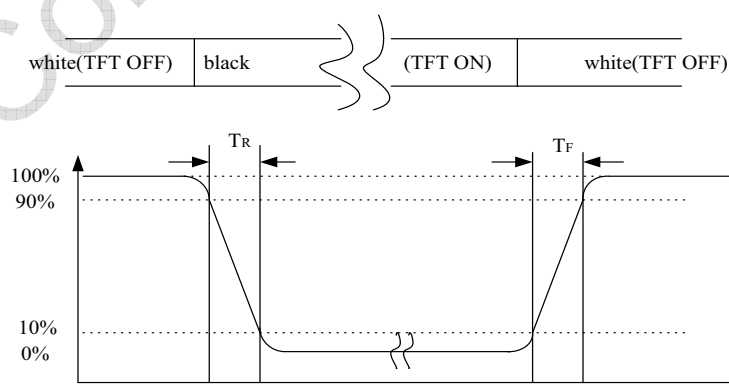



InfoVision Optoelectronics (Kunshan) Co.,LTD.

Document Title	M236MWF1 Customer Approved Specification			Page No.	10/29
Document No.	A-M236MWF1-R2-12-02	Issue date	2010/1/29	Revision	00

E. Definition of Luminance White

Measure the luminance of gray level 255 at center point

F. Definition of Luminance Uniformity(Variation)

Measure the luminance of gray level 255 at 9 points.

$$UNF(9pts) = \frac{\min(L1, L2, \dots, L9)}{\max(L1, L2, \dots, L9)}$$

Figure 7 Measurement Locations of 9 Points

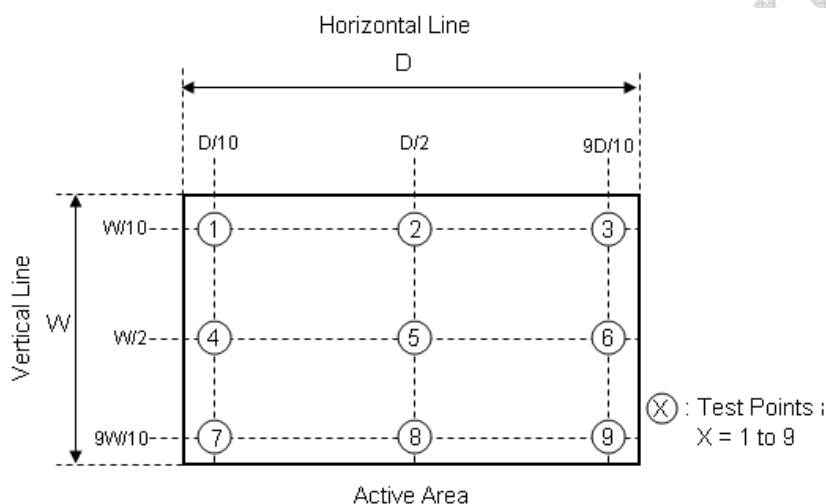



InfoVision Optoelectronics (Kunshan) Co.,LTD.

Document Title	M236MWF1 Customer Approved Specification			Page No.	11/29
Document No.	A-M236MWF1-R2-12-02	Issue date	2010/1/29	Revision	00

5.0 Backlight Characteristics

5.1 CCFL Connector

Table 3 Connector Name / Designation

Manufacturer	Yeonho
Type / Part Number	35001HS-02L

Table 4 Signal Assignment

Pin #	Signal Name
1	Lamp High Voltage
2	Lamp Low Voltage

5.2 Parameter Guideline for CCFL Inverter

Table 5 Parameter Guideline For CCFL Inverter

Symbol	Parameter	Min	Design Point	Max	Units	Condition
(L255)	White Luminance (Center)	250	300	--	[cd/m ²]	Ta=25[deg C]
ICCFL	CCFL current	3	7.0	8	[mA]	Ta=25[deg C] (Note A)
FCCFL	CCFL Frequency	40	--	80	[kHz]	Ta=25[deg C] (Note B)
VCCFLi	Inverter Ignition Voltage	1500	--	--	[Vrms]	Ta=25[deg C] (Note C)
		1900	--	--	[Vrms]	Ta=0[deg C] (Note C)
VCCFL	CCFL Voltage	792	880	968	[Vrms]	@ ICCFL=7.0mA Ta=25[deg C]

Note:

- If it exceeds MIN/MAX values, then "CCFL Life", "ON/OFF Cycle", and "SAFETY" will not be guaranteed.
- CCFL Frequency should be carefully determined to avoid interference between inverter and TFT LCD.
- The voltage over specified value (VCCFLi) should be applied to the lamp more than 1 second after startup. Otherwise, the lamp may not be turned on. The used lamp current is the lamp typical current. The inverter should be able to give out a power that has a generating capacity of over 1900 voltage. Lamp units need to over 1900 voltage for ignition.



InfoVision Optoelectronics (Kunshan) Co.,LTD.

Document Title	M236MWF1 Customer Approved Specification			Page No.	12/29
Document No.	A-M236MWF1-R2-12-02	Issue date	2010/1/29	Revision	00

D. The distortion rate of the waveform should be within $\sqrt{2}\pm 10\%$

The inverter output waveform should be better similar to the ideal sine wave.

$$\text{Asymmetry rate} = |I_p - I_{-p}| / I_{rms} \times 100\%$$

$$\text{Distortion rate} = I_p \text{ (or } I_{-p}) / I_{rms}$$

Figure 8 Recommendation of Lighting Waveform

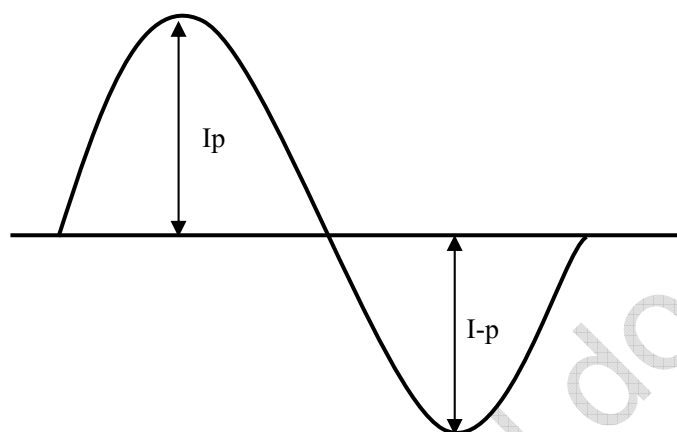



InfoVision Optoelectronics (Kunshan) Co.,LTD.

Document Title	M236MWF1 Customer Approved Specification			Page No.	13/29
Document No.	A-M236MWF1-R2-12-02	Issue date	2010/1/29	Revision	00

6.0 Electrical Characteristics

6.1 Interface Connector

Table 6 Connector Name / Designation

Manufacturer	JAE (or equivalent)
Type / Part Number	UJU IS100-L30B-C23
Mating Receptacle/Part Number	JAE FI-X30H(L), JAE FI-X30C*(L), JAE FI-X30M*

Table 7 Signal Pin Assignment

Pin #	Signal Name	Description	Remarks
1	RXinO0-	LVDS differential data input	
2	RXinO0+	LVDS differential data input	
3	RXinO1-	LVDS differential data input	
4	RXinO1+	LVDS differential data input	
5	RXinO2-	LVDS differential data input	
6	RXinO2+	LVDS differential data input	
7	GND	Ground	
8	RXOC-	LVDS differential data input	
9	RXOC+	LVDS differential data input	
10	RXinO3-	LVDS differential data input	
11	RXinO3+	LVDS differential data input	
12	RXinE0-	LVDS differential data input	
13	RXinE0+	LVDS differential data input	
14	GND	Ground	
15	RXinE1-	LVDS differential data input	
16	RXinE1+	LVDS differential data input	
17	GND	Ground	
18	RXinE2-	LVDS differential data input	
19	RXinE2+	LVDS differential data input	
20	RXEC-	LVDS differential data input	
21	RXEC+	LVDS differential data input	
22	RXinE3-	LVDS differential data input	
23	RXinE3+	LVDS differential data input	
24	GND	Ground	
25	GND	Ground	
26	NC	Reserved for LCD manufacturer.	
27	GND	Ground	
28	VDD	Power Supply	



InfoVision Optoelectronics (Kunshan) Co.,LTD.

Document Title	M236MWF1 Customer Approved Specification			Page No.	14/29
Document No.	A-M236MWF1-R2-12-02	Issue date	2010/1/29	Revision	00

29	VDD	Power Supply	
30	VDD	Power Supply	

All input signals shall be low or Hi-Z state when VDD is off.



InfoVision Optoelectronics (Kunshan) Co.,LTD.

Document Title	M236MWF1 Customer Approved Specification			Page No.	15/29
Document No.	A-M236MWF1-R2-12-02	Issue date	2010/1/29	Revision	00

6.2 LVDS Receiver

6.2.1 Signal Electrical Characteristics for LVDS Receiver

The built-in LVDS receiver is compatible with ANSI/TIA/TIA-644 standard.

Table 8 LVDS Receiver Electrical Characteristics

Parameter	Symbol	Min	Typ	Max	Unit	Conditions
Differential Input High Threshold	Vth	--	--	+100	mV	Vcm=+1.2V
Differential Input Low Threshold	Vtl	-100	--	--	mV	Vcm=+1.2V
Magnitude Differential Input Voltage	Vid	100	--	600	mV	--
Common Mode Voltage	Vcm	1.0	1.2	1.4	V	Vth - Vtl = 200mV
Common Mode Voltage Offset	Δ Vcm	-50	--	+50	mV	Vth - Vtl = 200mV

Note:

A. Input signals shall be low or Hi-Z state when VDD is off.

B. All electrical characteristics for LVDS signal are defined and shall be measured at the interface connector of LCD.

Table 9 Timing Requirements

Parameter	Symbol	Min	Typ	Max	Unit	Conditions	Note
Clock Frequency	Fc	63.5	73.3	96.7	MHz	--	--
Input Data Skew Margin	Trskm	-850	--	+850	ps	Fc=73.26MHz, Vth-Vtl = 400mV Vcm = 1.2V, Δ Vcm = 0	(Figure 9)

Note: All values are at VDD=5.0V, Ta=25 degree C.



InfoVision Optoelectronics (Kunshan) Co.,LTD.

Document Title	M236MWF1 Customer Approved Specification			Page No.	16/29
Document No.	A-M236MWF1-R2-12-02	Issue date	2010/1/29	Revision	00

Figure 9 Voltage Definitions

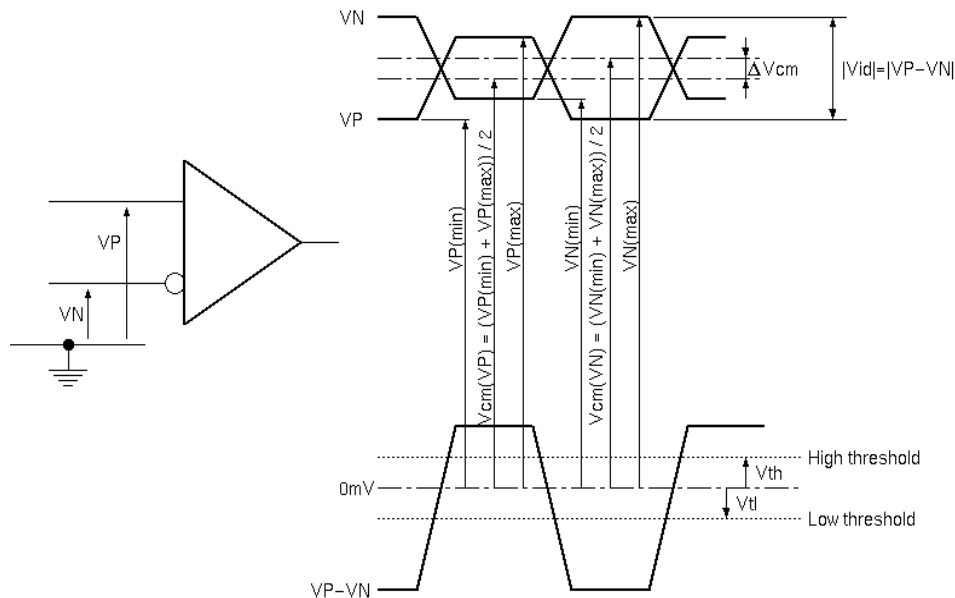
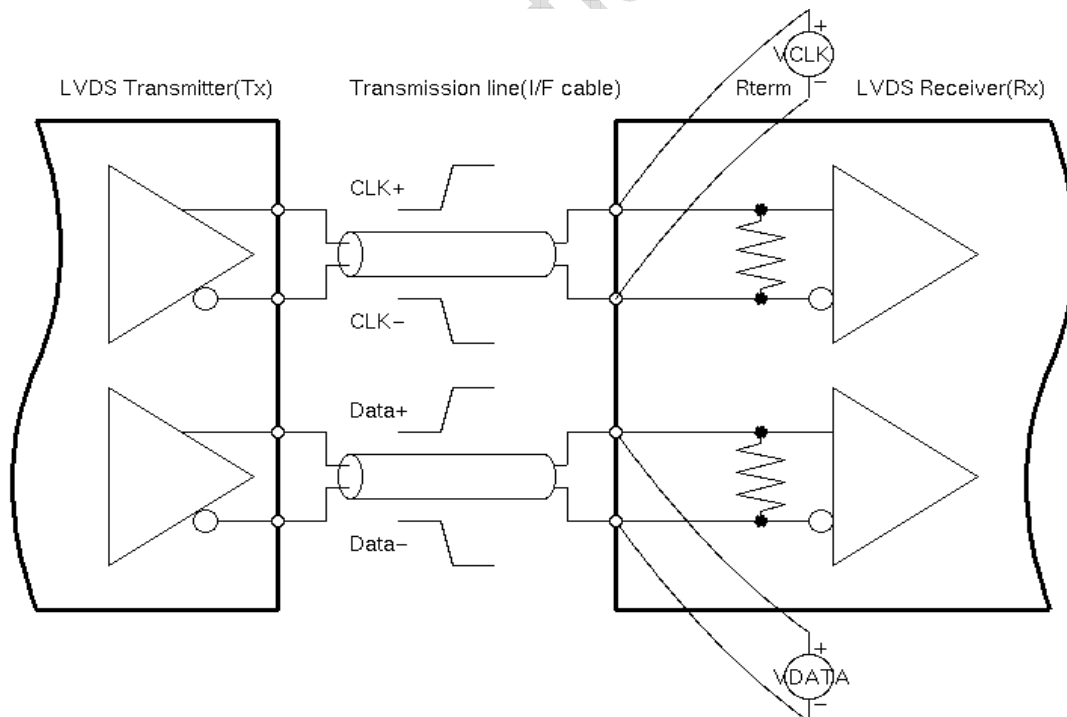

Figure 10 Measurement System





InfoVision Optoelectronics (Kunshan) Co.,LTD.

Document Title	M236MWF1 Customer Approved Specification			Page No.	17/29
Document No.	A-M236MWF1-R2-12-02	Issue date	2010/1/29	Revision	00

Figure 3 Data Mapping

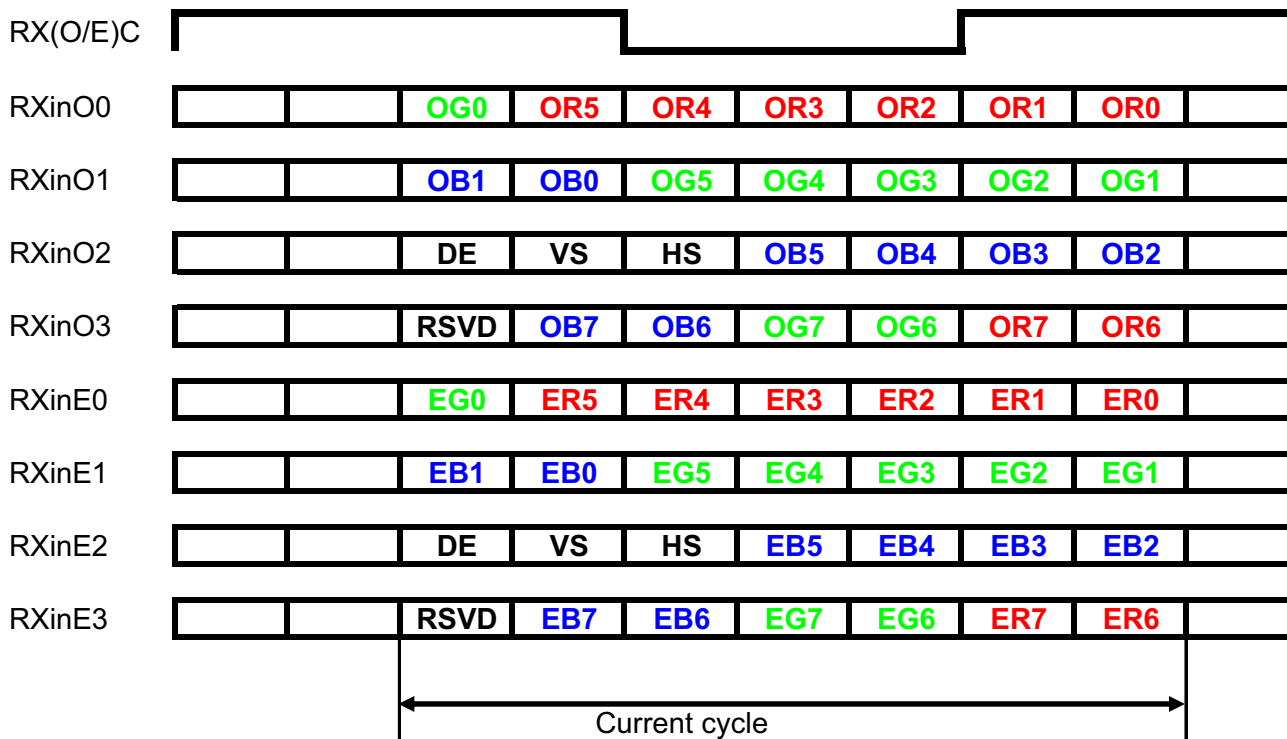

IVO Confidential



InfoVision Optoelectronics (Kunshan) Co.,LTD.

Document Title	M236MWF1 Customer Approved Specification			Page No.	18/29
Document No.	A-M236MWF1-R2-12-02	Issue date	2010/1/29	Revision	00

Figure 12 Timing Definition

Detail A

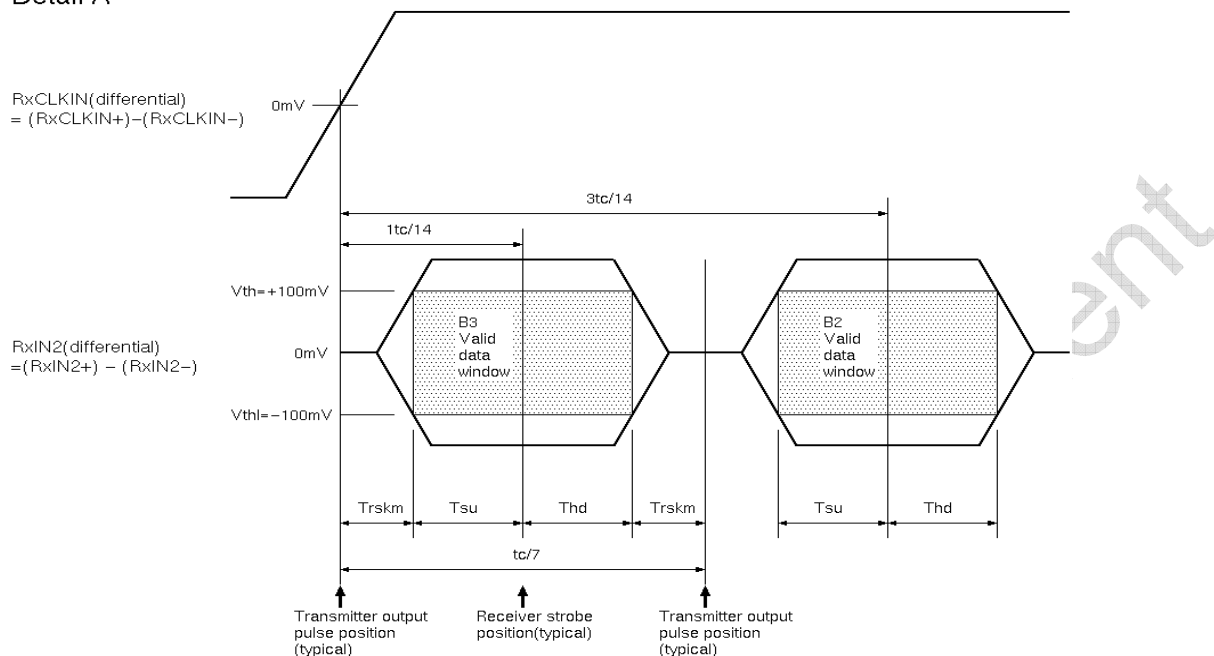

Note: Tsu and Thd is internal data sampling window of receiver. $Trskm$ is the system skew margin; i.e., the sum of cable skew, source clock jitter, and other inter-symbol interference, shall be less than $Trskm$.



InfoVision Optoelectronics (Kunshan) Co.,LTD.

Document Title	M236MWF1 Customer Approved Specification			Page No.	19/29
Document No.	A-M236MWF1-R2-12-02	Issue date	2010/1/29	Revision	00

6.2.2 LVDS Receiver Internal Circuit

Figure 4 LVDS Receiver Internal Circuit shows the internal block diagram of the LVDS receiver. This LCD module equips termination resistors for LVDS link.

Figure 4 LVDS Receiver Internal Circuit

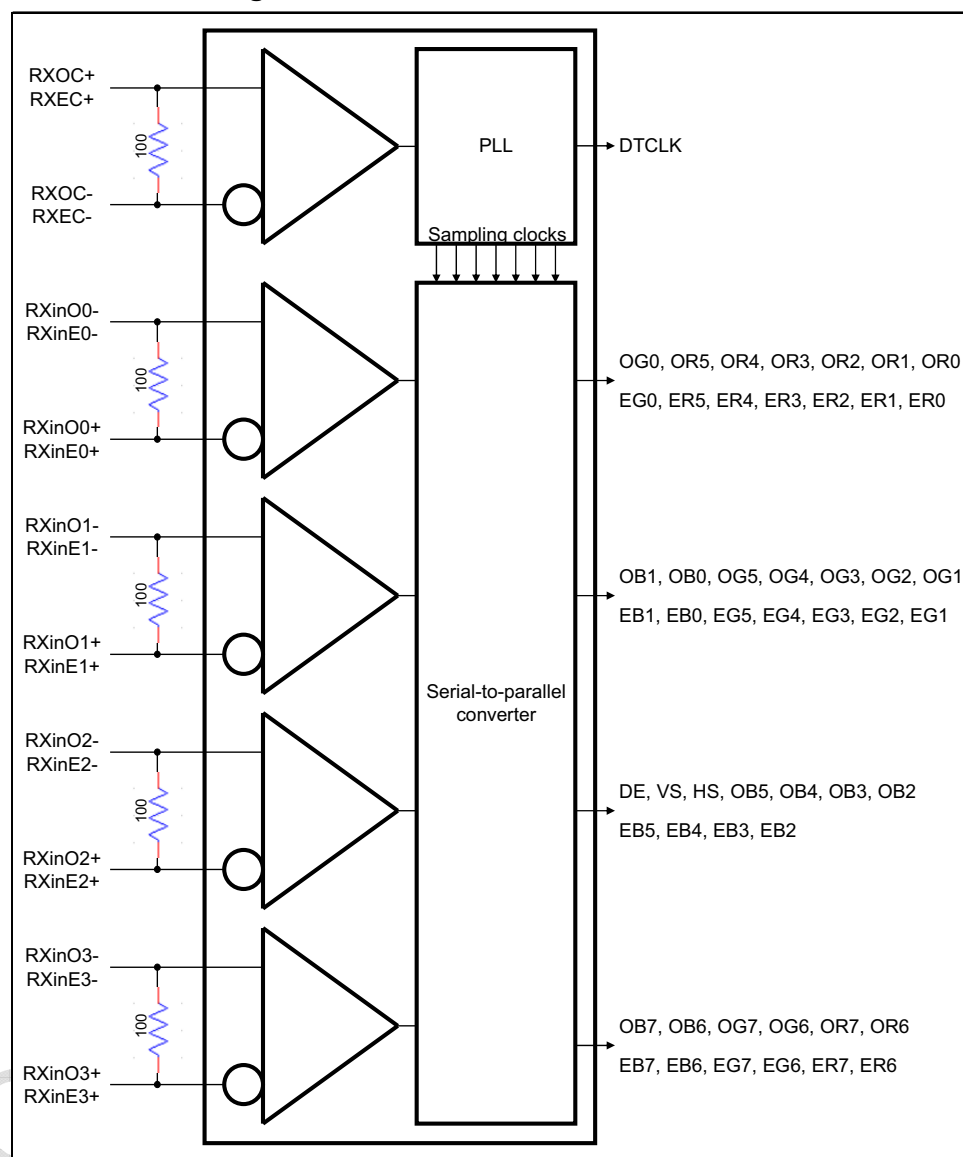



InfoVision Optoelectronics (Kunshan) Co.,LTD.

Document Title	M236MWF1 Customer Approved Specification			Page No.	20/29
Document No.	A-M236MWF1-R2-12-02	Issue date	2010/1/29	Revision	00

7.0 Interface Timings

7.1 Timing Characteristics

Table 10 Interface Timings

Parameter	Symbol	Unit	min	Typ	Max
LVDS Clock Frequency(dual)	Fdck	MHz	63.5	73.3	96.7
H Total Time	Htotal	clocks	1050	1100	1150
H Active Time	Hac	clocks	960	960	960
V Total Time	Vtotal	lines	1100	1110	1121
V Active Time	Vac	lines	1080	1080	1080
Frame Rate	Vsync	Hz	55	60	75

Figure 14 Timing Characteristics

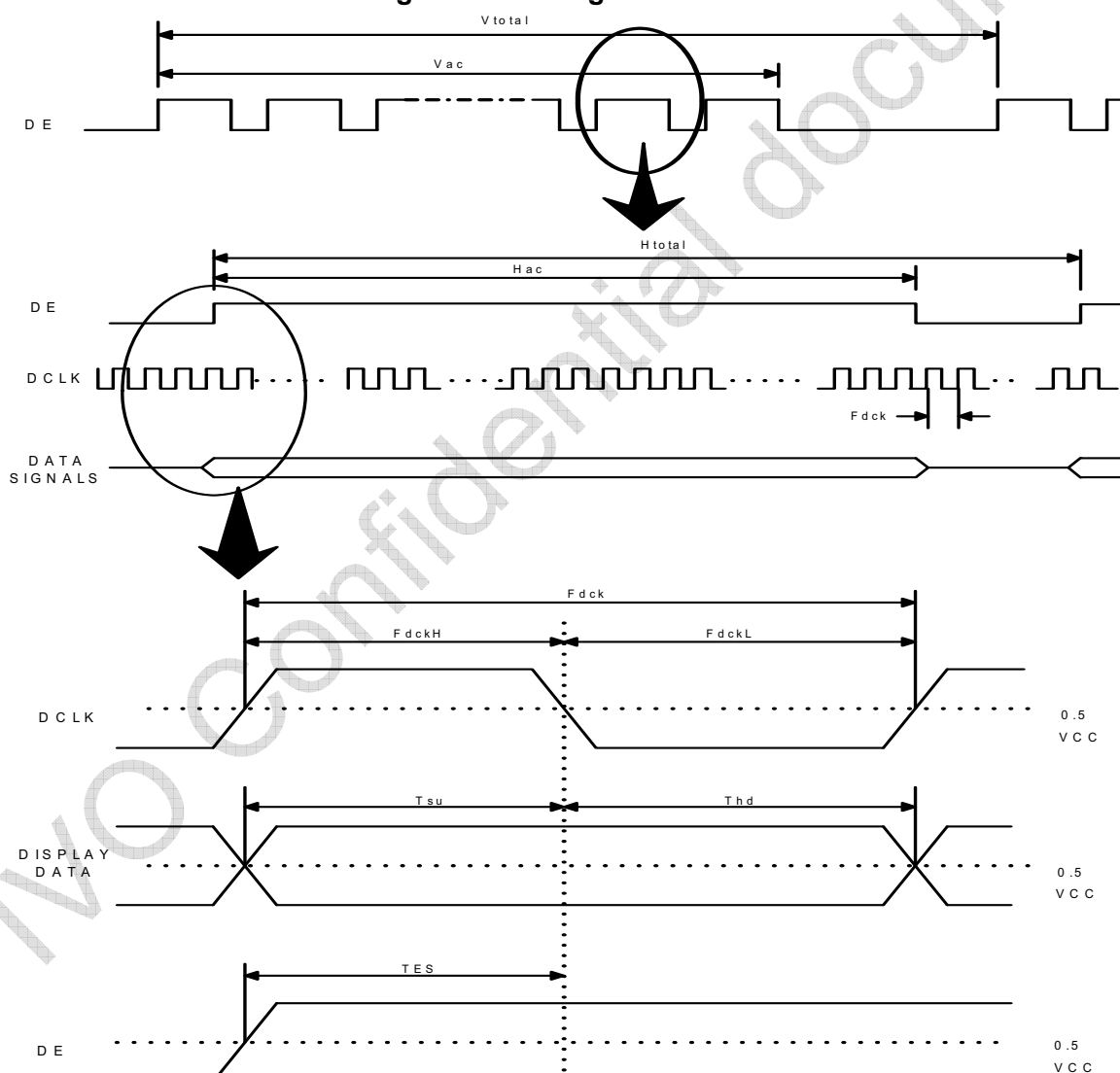



InfoVision Optoelectronics (Kunshan) Co.,LTD.

Document Title	M236MWF1 Customer Approved Specification			Page No.	21/29
Document No.	A-M236MWF1-R2-12-02	Issue date	2010/1/29	Revision	00

8.0 Power Consumption

Input power specifications are as follows.

Table 11 Power Consumption

Symbol L	Parameter	Min	Typ	Max	Units	Condition
VDD	Logic/LCD Drive Voltage	4.5	5.0	5.5	[V]	
IDD	VDD Current	--	0.85	1.02	[A]	All black pattern, 60Hz
		--	0.9	1.08	[A]	Max pattern, 60Hz
PDD	VDD Power	--	4.5	--	[W]	All black pattern, 60Hz
Irush	Rush Current	--	--	2.5	[A]	VDD rise time over 0.5ms. Oscilloscope Sampling over 2ms
VDDrp	Allowable Logic/LCD Drive Ripple Voltage	--	--	300	[mVp-p]	



InfoVision Optoelectronics (Kunshan) Co.,LTD.

Document Title	M236MWF1 Customer Approved Specification			Page No.	22/29
Document No.	A-M236MWF1-R2-12-02	Issue date	2010/1/29	Revision	00

9.0 Power ON/OFF sequence

VDD power, interface signals, and lamp on/off sequence are shown in

Figure .Signals shall be Hi-Z state or low level when VDD is off.

Figure 15 Power Sequence

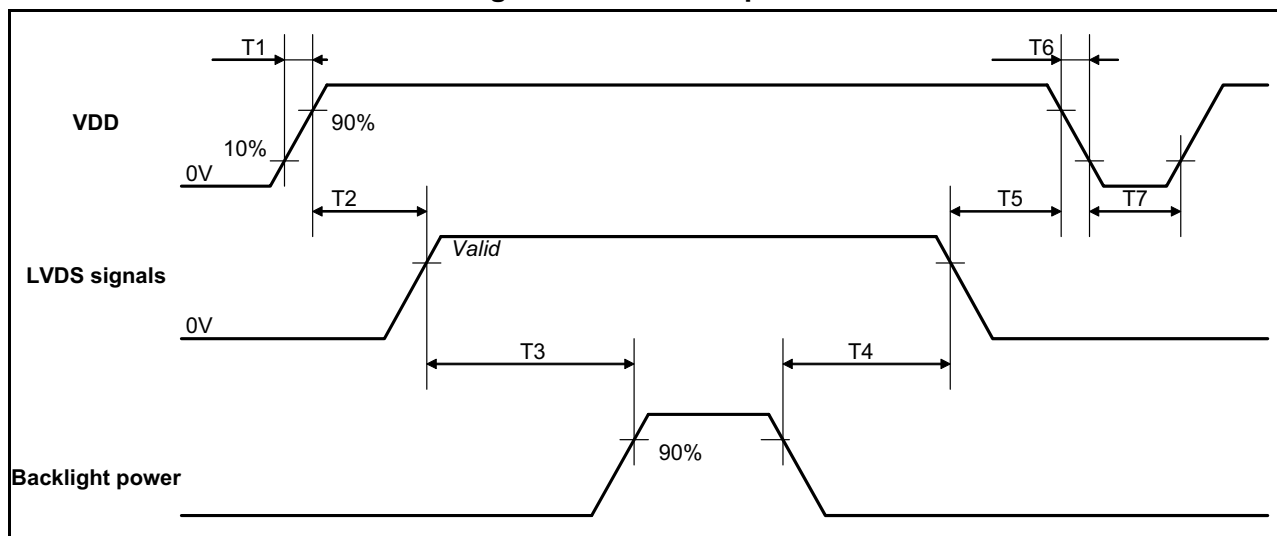

Table 12 Power Sequencing Requirements

Parameter	Symbol	Unit	Min	Typ	Max
VDD Rise Time	T1	ms	0.5	--	10
VDD Good to Signal Valid	T2	ms	0	--	50
Signal Valid to Backlight On	T3	ms	200	--	--
Backlight Off to Signal Disable	T4	ms	90	--	--
Signal Disable to Power Down	T5	ms	0	--	50
VDD Fall Time	T6	ms	0	--	100
Power Off	T7	ms	500	--	--



InfoVision Optoelectronics (Kunshan) Co.,LTD.

Document Title	M236MWF1 Customer Approved Specification			Page No.	23/29
Document No.	A-M236MWF1-R2-12-02	Issue date	2010/1/29	Revision	00

10.0 Mechanical Characteristics

Figure 16 Reference Outline Drawing (Front side)

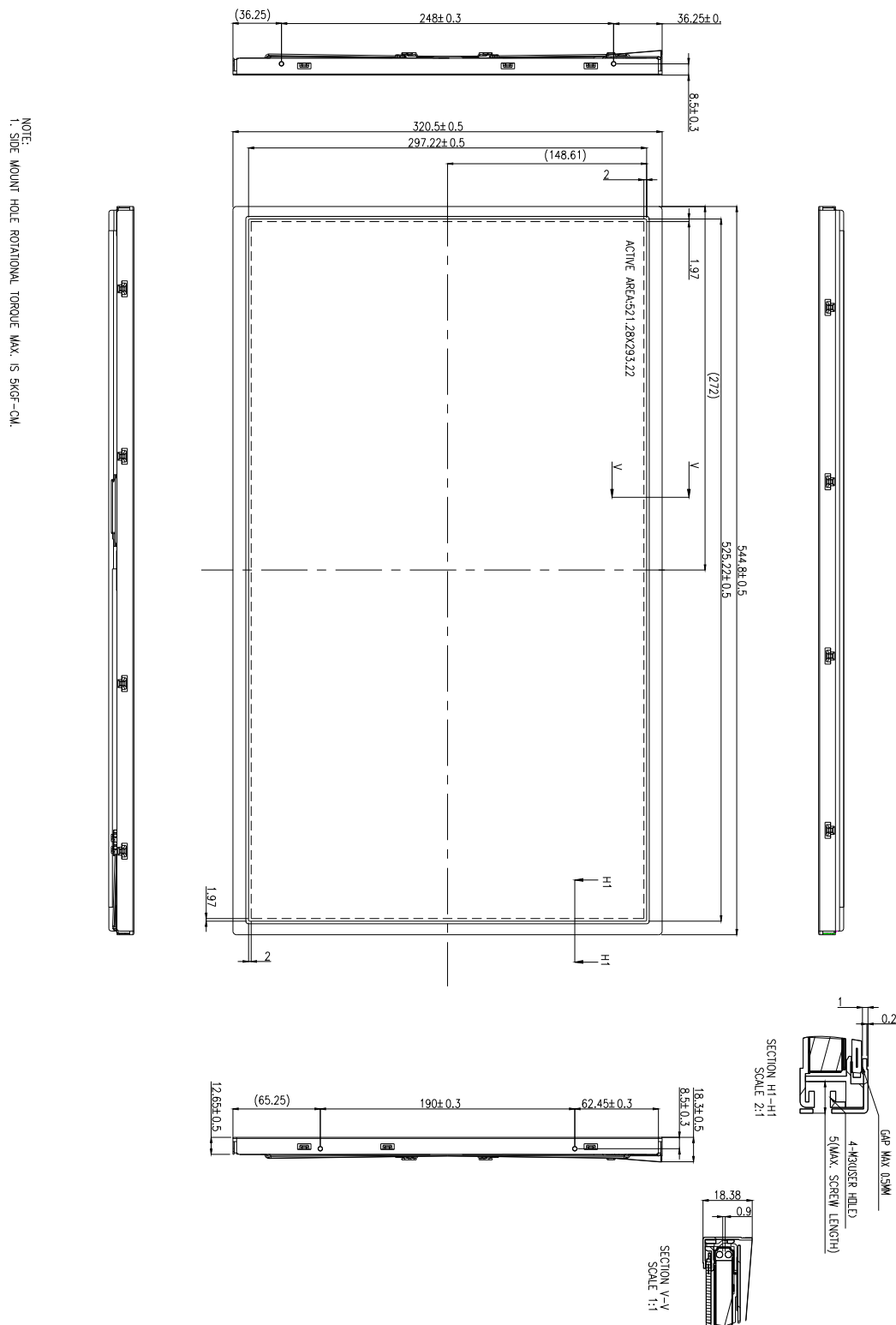



InfoVision Optoelectronics (Kunshan) Co.,LTD.

Document Title	M236MWF1 Customer Approved Specification			Page No.	24/29
Document No.	A-M236MWF1-R2-12-02	Issue date	2010/1/29	Revision	00

Figure 17 Reference Outline Drawing (Back side)

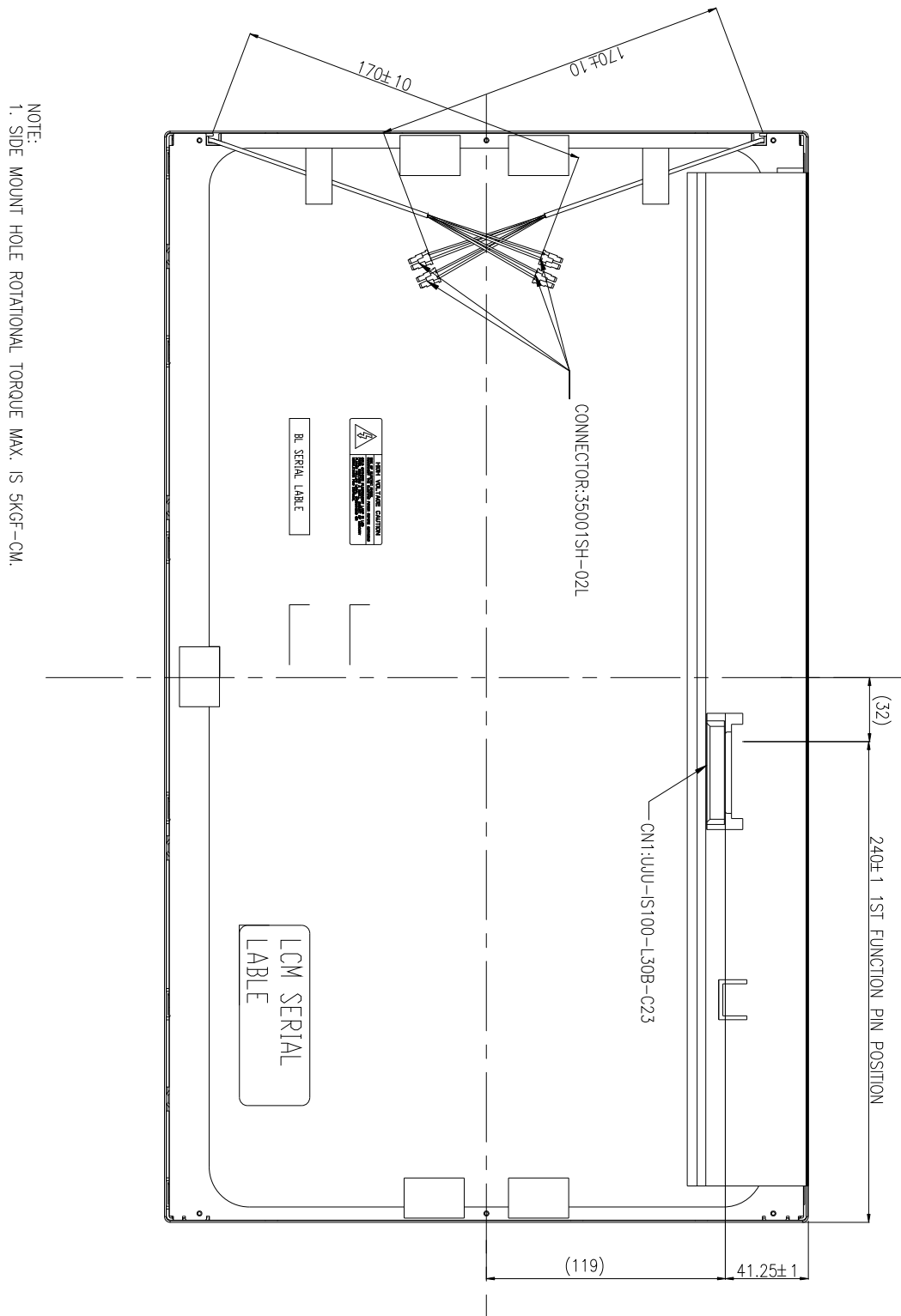



InfoVision Optoelectronics (Kunshan) Co.,LTD.

Document Title	M236MWF1 Customer Approved Specification			Page No.	25/29
Document No.	A-M236MWF1-R2-12-02	Issue date	2010/1/29	Revision	00

10.1 Dimension Specification

Table 13 Module Dimension Specifications

Width [mm]			544.8 ± 0.5
Height [mm]			320.5 ± 0.5
Thickness [mm]			18.38± 0.5
Bezel Opening [mm]	X		525.22± 0.5
	Y		297.22± 0.5
Mounting Hole [mm]	UR		65.25±0.3
	LR		65.25±0.3
	UL		36.25±0.3
	LL		36.25±0.3
Connector position from screen center [mm]	X		148.6±5
	Y		272±5
CCFL harness length [mm]			170± 10
Weight [g]			3250 typ
BM : a-b & c-d			≤1.0 mm

Figure 18

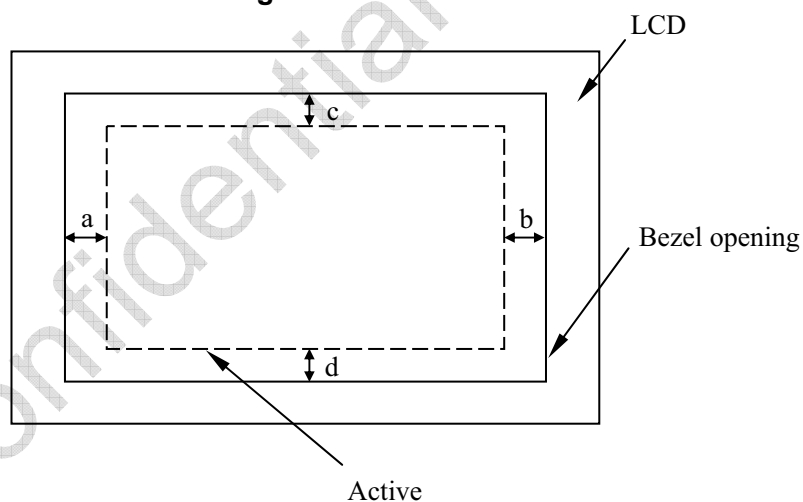



InfoVision Optoelectronics (Kunshan) Co.,LTD.

Document Title	M236MWF1 Customer Approved Specification			Page No.	26/29
Document No.	A-M236MWF1-R2-12-02	Issue date	2010/1/29	Revision	00

11.0 Package Specification.

Figure 19

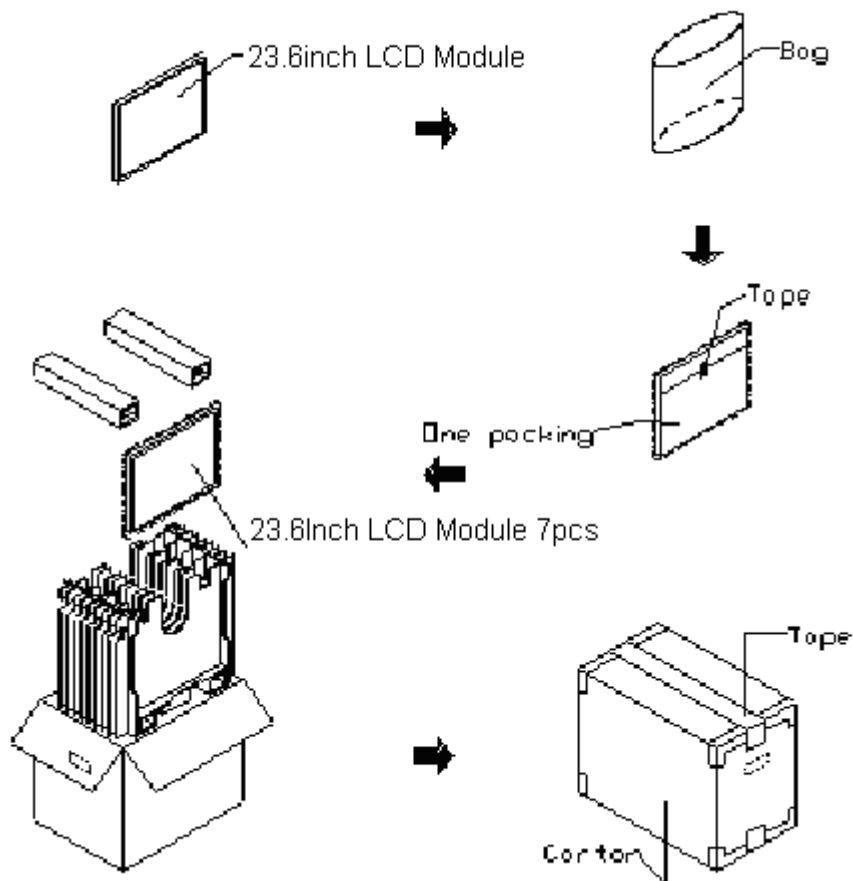

Sea/Land Transportation

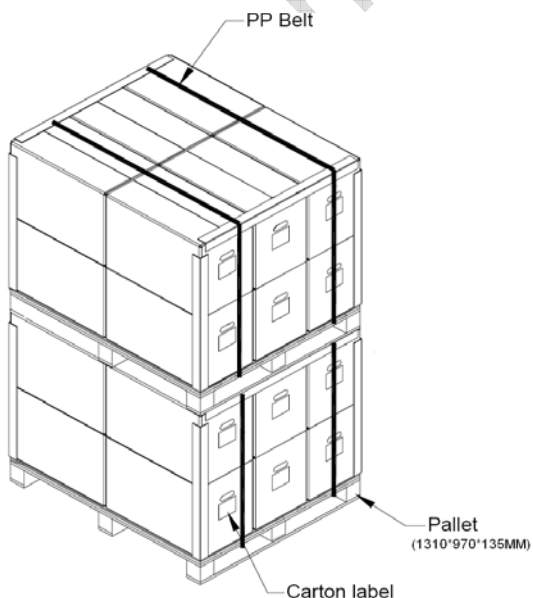

Air Transportation

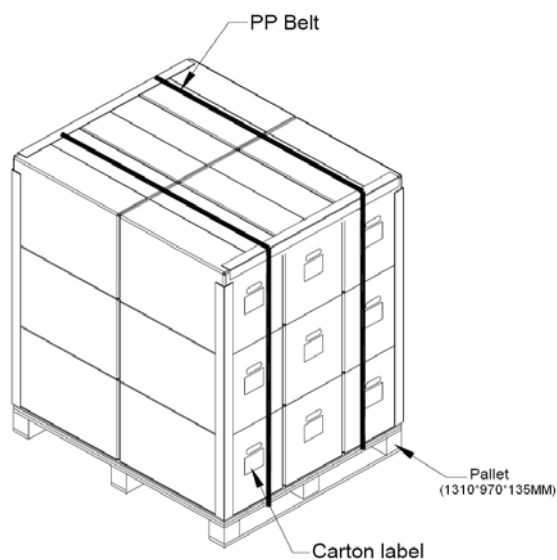



InfoVision Optoelectronics (Kunshan) Co.,LTD.

Document Title	M236MWF1 Customer Approved Specification			Page No.	27/29
Document No.	A-M236MWF1-R2-12-02	Issue date	2010/1/29	Revision	00

12.0 Lot Mark.

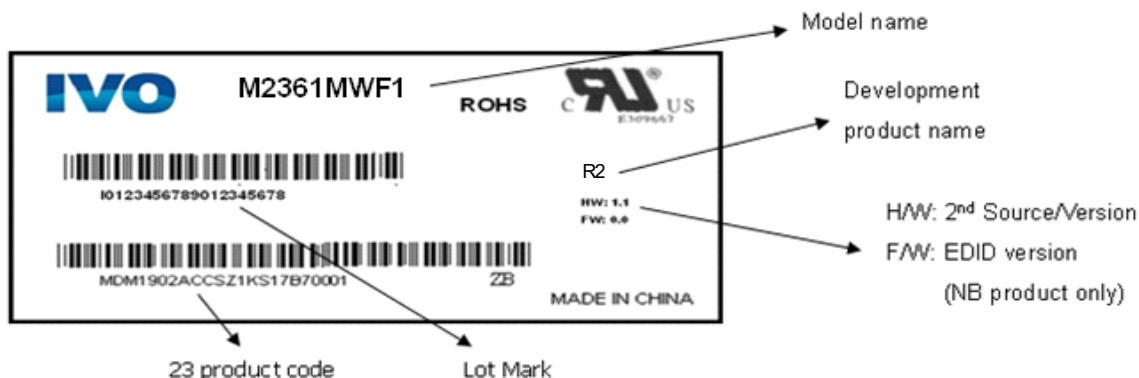

12.1 Lot Mark

1	2	3	4	5	6	7	8	9	10	11	12	13	14	15	16	17	18	19	20
---	---	---	---	---	---	---	---	---	----	----	----	----	----	----	----	----	----	----	----

code 1,2,3,6,7,8,9,10,11: IVO internal flow control code.
 code 5: production location.
 code 12: production year.
 code 13: production month.
 code 16,17,18,19,20: serial number.

Note (1) Production Year

Year	2006	2007	2008	2009	2010	2011	2012	2013	2014	2015
Mark	6	7	8	9	A	B	C	D	F	G

Note (2) Production Month

Month	Jan.	Feb.	Mar.	Apr.	May.	Jun.	Jul.	Aug.	Sep.	Oct.	Nov.	Dec.
Mark	1	2	3	4	5	6	7	8	9	A	B	C

12.2 23 product barcode

1	2	3	4	5	6	7	8	9	10	11	12	13	14	15	16	17	18	19	20	21	22	23
---	---	---	---	---	---	---	---	---	----	----	----	----	----	----	----	----	----	----	----	----	----	----

code 1,2: MD Mindtech Display.
 code 3,4,5,6,7: IVO internal module name.
 code 8,9,10,13,16: IVO internal flow control code.
 code 11,12: Cell location Suzhou defined as "SZ".
 code 14,15: Module line kunshan defined as "KS".
 code 17,18,19 : Year, Month, Day Refer to MTDIs barcode Note(1),Note(2).
 code 20~23 : Serial Number.



InfoVision Optoelectronics (Kunshan) Co.,LTD.

Document Title	M236MWF1 Customer Approved Specification			Page No.	28/29
Document No.	A-M236MWF1-R2-12-02	Issue date	2010/1/29	Revision	00

13.0 General Precaution

13.1 Use Restriction

This product is not authorized for use in life supporting systems, aircraft navigation control systems, military systems and any other application where performance failure could be life-threatening or otherwise catastrophic.

13.2 Disassembling or Modification

Do not disassemble or modify the module. It may damage sensitive parts inside LCD module, and may cause scratches or dust on the display. MTD does not warrant the module, if customers disassemble or modify the module.

13.3 Breakage of LCD Panel

13.3.1 If LCD panel is broken and liquid crystal spills out, do not ingest or inhale liquid Crystal, and do not contact liquid crystal with skin.

13.3.2 If liquid crystal contacts mouth or eyes, rinse out with water immediately.

13.3.3 If liquid crystal contacts skin or cloths, wash it off immediately with alcohol and Rinse thoroughly with water.

13.3.4 Handle carefully with chips of glass that may cause injury, when the glass is Broken

13.4 Electric Shock

13.4.1 Disconnect power supply before handling LCD module.

13.4.2 Do not pull or fold the CCFL cable.

13.4.3 Do not touch the parts inside LCD modules and the fluorescent lamp's connector

Or cables in order to prevent electric shock

13.5 Absolute Maximum Ratings and Power Protection Circuit

13.5.1 Do not exceed the absolute maximum rating values, such as the supply voltage variation, input voltage variation, variation in parts' parameters, environmental temperature; etc otherwise LCD module may be damaged.

13.5.2 Please do not leave LCD module in the environment of high humidity and high temperature for a long time.

13.5.3 It's recommended employing protection circuit for power supply.

13.6 Operation

13.6.1 Do not touch, push or rub the polarizer with anything harder than HB pencil lead.

Use fingerstalls of soft gloves in order to keep clean display quality, when Persons handle the LCD module for incoming inspection or assembly.

13.6.2 When the surface is dusty, please wipe gently with absorbent cotton or other soft

Material

13.6.3 Wipe off saliva or water drops as soon as possible. If saliva or water drops Contact with polarizer for a long time, they may causes deformation or color Fading

13.6.4 When cleaning the adhesives, please use absorbent cotton wetted with a little Petroleum benzene or other adequate solvent

13.7 Mechanism

Please mount LCD module by using mounting holes arranged in four corners tightly.



InfoVision Optoelectronics (Kunshan) Co.,LTD.

Document Title	M236MWF1 Customer Approved Specification			Page No.	29/29
Document No.	A-M236MWF1-R2-12-02	Issue date	2010/1/29	Revision	00

13.8 Static Electricity

13.8.1 Protection film must remove very slowly from the surface of LCD module to Prevent from electrostatic occurrence.

13.8.2 Because LCD module uses CMOS-IC on circuit board and TFT-LCD panel, it is Very weak to electrostatic discharge, Please be careful with electrostatic Discharge

13.8.3 Persons who handle the module should be grounded through adequate methods.

13.9 Strong Light Exposure

The module shall not be exposed under strong light such as direct sunlight. Otherwise, Display characteristics may be changed.

13.10 Disposal

When disposing LCD module, obey the local environmental regulations.