



() Preliminary Specification
(V) Final Specification

Module	23.8" Color TFT-LCD
Model Name	M238HVN01.2 open cell

Customer	Date
_____	_____
Approved by	

<p>Note: This Specification is subject to change without notice.</p>	

Approved by	Date
<u>Howard Lee</u>	<u>July. 20, 2015</u>
Prepared by	Date
<u>CJ Huang</u>	<u>July. 20, 2015</u>
<p>AU Optronics corporation</p>	

Contents

Draft version	3
Mechanical Characteristic	3
1 Handling Precautions	5
2 General Description	6
2.1 Display Characteristics	6
2.2 Absolute Maximum Rating of Environment.....	7
2.3 Optical Characteristics.....	8
3 TFT-LCD Module.....	12
3.1 Block Diagram.....	12
3.2 Interface Connection.....	13
3.2.1 Connector Type	13
3.2.2 Connector Pin Assignment.....	13
3.3 Electrical Characteristics.....	15
3.3.1 Absolute Maximum Rating.....	15
3.3.2 Recommended Operating Condition.....	15
3.4 Signal Characteristics	16
3.4.1 LCD Pixel Format	16
3.4.2 LVDS Data Format.....	16
3.4.3 Color versus Input Data	17
3.4.4 LVDS Specification	18
3.4.5 Input Timing Specification.....	20
3.4.6 Input Timing Diagram	21
3.5 Power ON/OFF Sequence	22
4 Reliability Test	23
5 Shipping Label	24
6 Mechanical Characteristic	25
7 Packing Specification	26
7.1 Packing Flow	26
7.2 Pallet and Shipment information.....	27

Record of Revision

Version	Date	Page	Old description	New Description	Remark																																																
0.0	2014/11/15	all	Draft version																																																		
0.1	2014/12/29	P5	2.1 Display Characteristics	2.1 Display Characteristics <table border="1"> <thead> <tr> <th>ITEMS</th> <th>Unit</th> <th>SPECIFICATIONS</th> </tr> </thead> <tbody> <tr> <td>Screen Diagonal</td> <td>[mm]</td> <td>(23.8")</td> </tr> <tr> <td>Active Area</td> <td>[mm]</td> <td>527.04(H) x 296.46(V)</td> </tr> <tr> <td>Pixel Pitch</td> <td>[mm]</td> <td>0.2745 x 0.2745</td> </tr> <tr> <td>Pixel Arrangement</td> <td>-</td> <td>R.G.B, Vertical Stripe</td> </tr> <tr> <td>Display Mode</td> <td>-</td> <td>VA Mode, Normally Black</td> </tr> <tr> <td>Response Time</td> <td>[msec]</td> <td>16 (Typ., auto/Off)</td> </tr> <tr> <td>Power Consumption</td> <td>[Watt]</td> <td>LCD module : PDD (Typ.)=5 @ White pattern,Fv=60Hz</td> </tr> <tr> <td>Weight</td> <td>[Gram]</td> <td>495.5 (Typ.)</td> </tr> <tr> <td>Electrical Interface</td> <td>-</td> <td>Dual channel LVDS, 8-bit RGB data input</td> </tr> <tr> <td>Support Color</td> <td>-</td> <td>16.7M colors</td> </tr> <tr> <td>Surface Treatment</td> <td>-</td> <td>Anti-Glare, 3H</td> </tr> <tr> <td>Temperature Range</td> <td>-</td> <td>0 to +50</td> </tr> <tr> <td>Operating Storage (Shipping)</td> <td>[°C]</td> <td>-20 to +60</td> </tr> <tr> <td>Cell transmittance</td> <td>[%]</td> <td>4.15 (Typ.) Base on AUO LED Backlight</td> </tr> <tr> <td>Cell thickness</td> <td>[mm]</td> <td>3.71 (Min.)</td> </tr> </tbody> </table>	ITEMS	Unit	SPECIFICATIONS	Screen Diagonal	[mm]	(23.8")	Active Area	[mm]	527.04(H) x 296.46(V)	Pixel Pitch	[mm]	0.2745 x 0.2745	Pixel Arrangement	-	R.G.B, Vertical Stripe	Display Mode	-	VA Mode, Normally Black	Response Time	[msec]	16 (Typ., auto/Off)	Power Consumption	[Watt]	LCD module : PDD (Typ.)=5 @ White pattern,Fv=60Hz	Weight	[Gram]	495.5 (Typ.)	Electrical Interface	-	Dual channel LVDS, 8-bit RGB data input	Support Color	-	16.7M colors	Surface Treatment	-	Anti-Glare, 3H	Temperature Range	-	0 to +50	Operating Storage (Shipping)	[°C]	-20 to +60	Cell transmittance	[%]	4.15 (Typ.) Base on AUO LED Backlight	Cell thickness	[mm]	3.71 (Min.)	
ITEMS	Unit	SPECIFICATIONS																																																			
Screen Diagonal	[mm]	(23.8")																																																			
Active Area	[mm]	527.04(H) x 296.46(V)																																																			
Pixel Pitch	[mm]	0.2745 x 0.2745																																																			
Pixel Arrangement	-	R.G.B, Vertical Stripe																																																			
Display Mode	-	VA Mode, Normally Black																																																			
Response Time	[msec]	16 (Typ., auto/Off)																																																			
Power Consumption	[Watt]	LCD module : PDD (Typ.)=5 @ White pattern,Fv=60Hz																																																			
Weight	[Gram]	495.5 (Typ.)																																																			
Electrical Interface	-	Dual channel LVDS, 8-bit RGB data input																																																			
Support Color	-	16.7M colors																																																			
Surface Treatment	-	Anti-Glare, 3H																																																			
Temperature Range	-	0 to +50																																																			
Operating Storage (Shipping)	[°C]	-20 to +60																																																			
Cell transmittance	[%]	4.15 (Typ.) Base on AUO LED Backlight																																																			
Cell thickness	[mm]	3.71 (Min.)																																																			
0.1	2014/12/29	P14	3.3.2 Recommended Operating Condition	3.3.2 Recommended Operating Condition <table border="1"> <thead> <tr> <th>Symbol</th> <th>Description</th> <th>Min</th> <th>Typ</th> <th>Max</th> <th>Unit</th> <th>Remark</th> </tr> </thead> <tbody> <tr> <td>VDD</td> <td>Power supply (Input voltage)</td> <td>4.5</td> <td>5.0</td> <td>5.5</td> <td>[V]</td> <td>VDD<sub>min</sub>: VDD<sub>min</sub>=4.5V</td> </tr> <tr> <td>VID</td> <td>Input Control voltage</td> <td>1.8</td> <td>1.52</td> <td>1.5</td> <td>[V]</td> <td>VDD<sub>min</sub>: VDD<sub>min</sub>=1.5V</td> </tr> <tr> <td>PDD</td> <td>VDD Power Consumption</td> <td>0.5</td> <td>0.5</td> <td>0.5</td> <td>[Watt]</td> <td>VDD<sub>min</sub>: VDD<sub>min</sub>=4.5V, Fv=60Hz</td> </tr> <tr> <td>Blank</td> <td>Blank Current</td> <td>0</td> <td>0</td> <td>0</td> <td>[mA]</td> <td>Blank<sub>min</sub>: Blank<sub>min</sub>=0mA</td> </tr> <tr> <td>VDDsp</td> <td>Minimum VDD (Spigging) Voltage</td> <td>500</td> <td>500</td> <td>500</td> <td>[mV]</td> <td>VDD<sub>min</sub>: VDD<sub>min</sub>=500mV</td> </tr> </tbody> </table>	Symbol	Description	Min	Typ	Max	Unit	Remark	VDD	Power supply (Input voltage)	4.5	5.0	5.5	[V]	VDD_{min}: VDD_{min}=4.5V	VID	Input Control voltage	1.8	1.52	1.5	[V]	VDD_{min}: VDD_{min}=1.5V	PDD	VDD Power Consumption	0.5	0.5	0.5	[Watt]	VDD_{min}: VDD_{min}=4.5V, Fv=60Hz	Blank	Blank Current	0	0	0	[mA]	Blank_{min}: Blank_{min}=0mA	VDDsp	Minimum VDD (Spigging) Voltage	500	500	500	[mV]	VDD_{min}: VDD_{min}=500mV							
Symbol	Description	Min	Typ	Max	Unit	Remark																																															
VDD	Power supply (Input voltage)	4.5	5.0	5.5	[V]	VDD_{min}: VDD_{min}=4.5V																																															
VID	Input Control voltage	1.8	1.52	1.5	[V]	VDD_{min}: VDD_{min}=1.5V																																															
PDD	VDD Power Consumption	0.5	0.5	0.5	[Watt]	VDD_{min}: VDD_{min}=4.5V, Fv=60Hz																																															
Blank	Blank Current	0	0	0	[mA]	Blank_{min}: Blank_{min}=0mA																																															
VDDsp	Minimum VDD (Spigging) Voltage	500	500	500	[mV]	VDD_{min}: VDD_{min}=500mV																																															
0.1	2014/12/29	All	Mechanical Characteristic CF-POL 302.26	6 Mechanical Characteristic CF-POL 304.26																																																	
1.0	2015/1/13	P5	2.1 Display Characteristics	2.1 Display Characteristics <table border="1"> <thead> <tr> <th>ITEMS</th> <th>Unit</th> <th>SPECIFICATIONS</th> </tr> </thead> <tbody> <tr> <td>Screen Diagonal</td> <td>[mm]</td> <td>(23.8")</td> </tr> <tr> <td>Active Area</td> <td>[mm]</td> <td>527.04(H) x 296.46(V)</td> </tr> <tr> <td>Pixel Pitch</td> <td>[mm]</td> <td>0.2745 x 0.2745</td> </tr> <tr> <td>Pixel Arrangement</td> <td>-</td> <td>R.G.B, Vertical Stripe</td> </tr> <tr> <td>Display Mode</td> <td>-</td> <td>VA Mode, Normally Black</td> </tr> <tr> <td>Response Time</td> <td>[msec]</td> <td>16 (Typ., auto/Off)</td> </tr> <tr> <td>Power Consumption</td> <td>[Watt]</td> <td>LCD module : PDD (Typ.)=5 @ White pattern,Fv=60Hz</td> </tr> <tr> <td>Weight</td> <td>[Gram]</td> <td>495.5 (Typ.)</td> </tr> <tr> <td>Electrical Interface</td> <td>-</td> <td>Dual channel LVDS, 8-bit RGB data input</td> </tr> <tr> <td>Support Color</td> <td>-</td> <td>16.7M colors</td> </tr> <tr> <td>Surface Treatment</td> <td>-</td> <td>Anti-Glare, 3H</td> </tr> <tr> <td>Temperature Range</td> <td>-</td> <td>0 to +50</td> </tr> <tr> <td>Operating Storage (Shipping)</td> <td>[°C]</td> <td>-20 to +60</td> </tr> <tr> <td>Cell transmittance</td> <td>[%]</td> <td>4.15 (Typ.) Base on AUO LED Backlight</td> </tr> <tr> <td>Cell thickness</td> <td>[mm]</td> <td>3.71 (Min.)</td> </tr> </tbody> </table>	ITEMS	Unit	SPECIFICATIONS	Screen Diagonal	[mm]	(23.8")	Active Area	[mm]	527.04(H) x 296.46(V)	Pixel Pitch	[mm]	0.2745 x 0.2745	Pixel Arrangement	-	R.G.B, Vertical Stripe	Display Mode	-	VA Mode, Normally Black	Response Time	[msec]	16 (Typ., auto/Off)	Power Consumption	[Watt]	LCD module : PDD (Typ.)=5 @ White pattern,Fv=60Hz	Weight	[Gram]	495.5 (Typ.)	Electrical Interface	-	Dual channel LVDS, 8-bit RGB data input	Support Color	-	16.7M colors	Surface Treatment	-	Anti-Glare, 3H	Temperature Range	-	0 to +50	Operating Storage (Shipping)	[°C]	-20 to +60	Cell transmittance	[%]	4.15 (Typ.) Base on AUO LED Backlight	Cell thickness	[mm]	3.71 (Min.)	
ITEMS	Unit	SPECIFICATIONS																																																			
Screen Diagonal	[mm]	(23.8")																																																			
Active Area	[mm]	527.04(H) x 296.46(V)																																																			
Pixel Pitch	[mm]	0.2745 x 0.2745																																																			
Pixel Arrangement	-	R.G.B, Vertical Stripe																																																			
Display Mode	-	VA Mode, Normally Black																																																			
Response Time	[msec]	16 (Typ., auto/Off)																																																			
Power Consumption	[Watt]	LCD module : PDD (Typ.)=5 @ White pattern,Fv=60Hz																																																			
Weight	[Gram]	495.5 (Typ.)																																																			
Electrical Interface	-	Dual channel LVDS, 8-bit RGB data input																																																			
Support Color	-	16.7M colors																																																			
Surface Treatment	-	Anti-Glare, 3H																																																			
Temperature Range	-	0 to +50																																																			
Operating Storage (Shipping)	[°C]	-20 to +60																																																			
Cell transmittance	[%]	4.15 (Typ.) Base on AUO LED Backlight																																																			
Cell thickness	[mm]	3.71 (Min.)																																																			
1.1	2015/04/08	P5	2.1 Display Characteristics	2.1 Display Characteristics <table border="1"> <thead> <tr> <th>ITEMS</th> <th>Unit</th> <th>SPECIFICATIONS</th> </tr> </thead> <tbody> <tr> <td>Screen Diagonal</td> <td>[mm]</td> <td>(23.8")</td> </tr> <tr> <td>Active Area</td> <td>[mm]</td> <td>527.04(H) x 296.46(V)</td> </tr> <tr> <td>Pixel Pitch</td> <td>[mm]</td> <td>0.2745 (per one triad) x 0.2745</td> </tr> <tr> <td>Pixel Arrangement</td> <td>-</td> <td>R.G.B, Vertical Stripe</td> </tr> <tr> <td>Display Mode</td> <td>-</td> <td>VA Mode, Normally Black</td> </tr> <tr> <td>Response Time</td> <td>[msec]</td> <td>20 (Typ., G/G)</td> </tr> <tr> <td>Power Consumption</td> <td>[Watt]</td> <td>LCD module : PDD (Typ.)=5 @ White pattern,Fv=60Hz</td> </tr> <tr> <td>Weight</td> <td>[Gram]</td> <td>495.5 (Typ.)</td> </tr> <tr> <td>Electrical Interface</td> <td>-</td> <td>Dual channel LVDS, 8-bit RGB data input</td> </tr> <tr> <td>Support Color</td> <td>-</td> <td>16.7M colors</td> </tr> <tr> <td>Surface Treatment</td> <td>-</td> <td>Anti-Glare, 3H</td> </tr> <tr> <td>Temperature Range</td> <td>-</td> <td>0 to +50</td> </tr> <tr> <td>Operating Storage (Shipping)</td> <td>[°C]</td> <td>-20 to +60</td> </tr> <tr> <td>Cell transmittance</td> <td>[%]</td> <td>4.15 (Typ.) Base on AUO LED Backlight</td> </tr> <tr> <td>Cell thickness</td> <td>[mm]</td> <td>1.36 (Thickness of polarizer film: 0.18 mm each side)</td> </tr> </tbody> </table>	ITEMS	Unit	SPECIFICATIONS	Screen Diagonal	[mm]	(23.8")	Active Area	[mm]	527.04(H) x 296.46(V)	Pixel Pitch	[mm]	0.2745 (per one triad) x 0.2745	Pixel Arrangement	-	R.G.B, Vertical Stripe	Display Mode	-	VA Mode, Normally Black	Response Time	[msec]	20 (Typ., G/G)	Power Consumption	[Watt]	LCD module : PDD (Typ.)=5 @ White pattern,Fv=60Hz	Weight	[Gram]	495.5 (Typ.)	Electrical Interface	-	Dual channel LVDS, 8-bit RGB data input	Support Color	-	16.7M colors	Surface Treatment	-	Anti-Glare, 3H	Temperature Range	-	0 to +50	Operating Storage (Shipping)	[°C]	-20 to +60	Cell transmittance	[%]	4.15 (Typ.) Base on AUO LED Backlight	Cell thickness	[mm]	1.36 (Thickness of polarizer film: 0.18 mm each side)	
ITEMS	Unit	SPECIFICATIONS																																																			
Screen Diagonal	[mm]	(23.8")																																																			
Active Area	[mm]	527.04(H) x 296.46(V)																																																			
Pixel Pitch	[mm]	0.2745 (per one triad) x 0.2745																																																			
Pixel Arrangement	-	R.G.B, Vertical Stripe																																																			
Display Mode	-	VA Mode, Normally Black																																																			
Response Time	[msec]	20 (Typ., G/G)																																																			
Power Consumption	[Watt]	LCD module : PDD (Typ.)=5 @ White pattern,Fv=60Hz																																																			
Weight	[Gram]	495.5 (Typ.)																																																			
Electrical Interface	-	Dual channel LVDS, 8-bit RGB data input																																																			
Support Color	-	16.7M colors																																																			
Surface Treatment	-	Anti-Glare, 3H																																																			
Temperature Range	-	0 to +50																																																			
Operating Storage (Shipping)	[°C]	-20 to +60																																																			
Cell transmittance	[%]	4.15 (Typ.) Base on AUO LED Backlight																																																			
Cell thickness	[mm]	1.36 (Thickness of polarizer film: 0.18 mm each side)																																																			
1.1	2015/04/08	P21	3.5 Power ON/OFF Sequence	3.5 Power ON/OFF Sequence <table border="1"> <thead> <tr> <th rowspan="2">Symbol</th> <th colspan="3">Value</th> <th rowspan="2">Unit</th> <th rowspan="2">Remark</th> </tr> <tr> <th>Min.</th> <th>Typ.</th> <th>Max.</th> </tr> </thead> <tbody> <tr> <td>T1</td> <td>0.5</td> <td>-</td> <td>10</td> <td>[ms]</td> <td></td> </tr> <tr> <td>T2</td> <td>0</td> <td>-</td> <td>50</td> <td>[ms]</td> <td></td> </tr> <tr> <td>T3</td> <td>500</td> <td>-</td> <td>-</td> <td>[ms]</td> <td></td> </tr> <tr> <td>T4</td> <td>100</td> <td>-</td> <td>-</td> <td>[ms]</td> <td></td> </tr> <tr> <td>T5</td> <td>0</td> <td>-</td> <td>50</td> <td>[ms]</td> <td>Note 3-5</td> </tr> <tr> <td>T7</td> <td>1000</td> <td>-</td> <td>-</td> <td>[ms]</td> <td>Note 3-6</td> </tr> </tbody> </table>	Symbol	Value			Unit	Remark	Min.	Typ.	Max.	T1	0.5	-	10	[ms]		T2	0	-	50	[ms]		T3	500	-	-	[ms]		T4	100	-	-	[ms]		T5	0	-	50	[ms]	Note 3-5	T7	1000	-	-	[ms]	Note 3-6				
Symbol	Value			Unit		Remark																																															
	Min.	Typ.	Max.																																																		
T1	0.5	-	10	[ms]																																																	
T2	0	-	50	[ms]																																																	
T3	500	-	-	[ms]																																																	
T4	100	-	-	[ms]																																																	
T5	0	-	50	[ms]	Note 3-5																																																
T7	1000	-	-	[ms]	Note 3-6																																																
1.1	2015/04/08	P24	6 Mechanical Characteristic	6 Mechanical Characteristic 																																																	

1.2	2015/6/1	P5	2.1 Display Characteristics <table border="1"> <tr> <td>Power Consumption</td> <td>[Watt]</td> <td>LCD module : PDD (Typ.)=5 @ White pattern, Fv=60Hz</td> </tr> </table>	Power Consumption	[Watt]	LCD module : PDD (Typ.)=5 @ White pattern, Fv=60Hz	2.1 Display Characteristics <table border="1"> <tr> <td>Power Consumption</td> <td>[Watt]</td> <td>LCD module : PDD (Typ.)=3.8 @ White pattern, Fv=60Hz</td> </tr> </table>	Power Consumption	[Watt]	LCD module : PDD (Typ.)=3.8 @ White pattern, Fv=60Hz																																																																																																						
Power Consumption	[Watt]	LCD module : PDD (Typ.)=5 @ White pattern, Fv=60Hz																																																																																																														
Power Consumption	[Watt]	LCD module : PDD (Typ.)=3.8 @ White pattern, Fv=60Hz																																																																																																														
1.2	2015/6/1	P15	3.3.2 Recommended Operating Condition <table border="1"> <thead> <tr> <th>Symbol</th> <th>Description</th> <th>Min</th> <th>Typ</th> <th>Max</th> <th>Unit</th> <th>Remark</th> </tr> </thead> <tbody> <tr> <td>VDD</td> <td>Power supply input voltage</td> <td>4.5</td> <td>5.0</td> <td>5.5</td> <td>[Volt]</td> <td></td> </tr> <tr> <td rowspan="2">IDD</td> <td>Power supply input Current (ave)</td> <td>-</td> <td>1.0</td> <td>1.2</td> <td>[A]</td> <td>VDD= 5.0V, All white Pattern, Fv=60Hz</td> </tr> <tr> <td></td> <td>-</td> <td>1.1</td> <td>1.4</td> <td>[A]</td> <td>VDD= 5.0V, All white Pattern, Fv=75Hz</td> </tr> <tr> <td rowspan="2">PDD</td> <td>VDD Power Consumption</td> <td>-</td> <td>5.0</td> <td>6.0</td> <td>[Watt]</td> <td>VDD= 5.0V, All white Pattern, Fv=60Hz</td> </tr> <tr> <td></td> <td>-</td> <td>5.5</td> <td>6.6</td> <td>[Watt]</td> <td>VDD= 5.0V, All white Pattern, Fv=75Hz</td> </tr> <tr> <td>IRush</td> <td>Inrush Current</td> <td>-</td> <td>-</td> <td>3.0</td> <td>[A]</td> <td>Note 3-1</td> </tr> <tr> <td>VDDrip</td> <td>Allowable VDD Ripple Voltage</td> <td>-</td> <td>-</td> <td>500</td> <td>[mV]</td> <td>VDD= 5.0V, All white Pattern, Fv=75Hz</td> </tr> </tbody> </table>	Symbol	Description	Min	Typ	Max	Unit	Remark	VDD	Power supply input voltage	4.5	5.0	5.5	[Volt]		IDD	Power supply input Current (ave)	-	1.0	1.2	[A]	VDD= 5.0V, All white Pattern, Fv=60Hz		-	1.1	1.4	[A]	VDD= 5.0V, All white Pattern, Fv=75Hz	PDD	VDD Power Consumption	-	5.0	6.0	[Watt]	VDD= 5.0V, All white Pattern, Fv=60Hz		-	5.5	6.6	[Watt]	VDD= 5.0V, All white Pattern, Fv=75Hz	IRush	Inrush Current	-	-	3.0	[A]	Note 3-1	VDDrip	Allowable VDD Ripple Voltage	-	-	500	[mV]	VDD= 5.0V, All white Pattern, Fv=75Hz	3.3.2 Recommended Operating Condition <table border="1"> <thead> <tr> <th>Symbol</th> <th>Description</th> <th>Min</th> <th>Typ</th> <th>Max</th> <th>Unit</th> <th>Remark</th> </tr> </thead> <tbody> <tr> <td>VDD</td> <td>Power supply input voltage</td> <td>4.5</td> <td>5.0</td> <td>5.5</td> <td>[Volt]</td> <td></td> </tr> <tr> <td rowspan="2">IDD</td> <td>Power supply input Current (ave)</td> <td>-</td> <td>0.76</td> <td>1.0</td> <td>[A]</td> <td>VDD= 5.0V, All white Pattern, Fv=60Hz</td> </tr> <tr> <td></td> <td>-</td> <td>0.86</td> <td>1.08</td> <td>[A]</td> <td>VDD= 5.0V, All white Pattern, Fv=75Hz</td> </tr> <tr> <td rowspan="2">PDD</td> <td>VDD Power Consumption</td> <td>-</td> <td>3.8</td> <td>5.0</td> <td>[Watt]</td> <td>VDD= 5.0V, All white Pattern, Fv=60Hz</td> </tr> <tr> <td></td> <td>-</td> <td>4.3</td> <td>5.4</td> <td>[Watt]</td> <td>VDD= 5.0V, All white Pattern, Fv=75Hz</td> </tr> <tr> <td>IRush</td> <td>Inrush Current</td> <td>-</td> <td>-</td> <td>3.0</td> <td>[A]</td> <td>Note 3-1</td> </tr> <tr> <td>VDDrip</td> <td>Allowable VDD Ripple Voltage</td> <td>-</td> <td>-</td> <td>500</td> <td>[mV]</td> <td>VDD= 5.0V, All white Pattern, Fv=75Hz</td> </tr> </tbody> </table>	Symbol	Description	Min	Typ	Max	Unit	Remark	VDD	Power supply input voltage	4.5	5.0	5.5	[Volt]		IDD	Power supply input Current (ave)	-	0.76	1.0	[A]	VDD= 5.0V, All white Pattern, Fv=60Hz		-	0.86	1.08	[A]	VDD= 5.0V, All white Pattern, Fv=75Hz	PDD	VDD Power Consumption	-	3.8	5.0	[Watt]	VDD= 5.0V, All white Pattern, Fv=60Hz		-	4.3	5.4	[Watt]	VDD= 5.0V, All white Pattern, Fv=75Hz	IRush	Inrush Current	-	-	3.0	[A]	Note 3-1	VDDrip	Allowable VDD Ripple Voltage	-	-	500	[mV]	VDD= 5.0V, All white Pattern, Fv=75Hz
Symbol	Description	Min	Typ	Max	Unit	Remark																																																																																																										
VDD	Power supply input voltage	4.5	5.0	5.5	[Volt]																																																																																																											
IDD	Power supply input Current (ave)	-	1.0	1.2	[A]	VDD= 5.0V, All white Pattern, Fv=60Hz																																																																																																										
		-	1.1	1.4	[A]	VDD= 5.0V, All white Pattern, Fv=75Hz																																																																																																										
PDD	VDD Power Consumption	-	5.0	6.0	[Watt]	VDD= 5.0V, All white Pattern, Fv=60Hz																																																																																																										
		-	5.5	6.6	[Watt]	VDD= 5.0V, All white Pattern, Fv=75Hz																																																																																																										
IRush	Inrush Current	-	-	3.0	[A]	Note 3-1																																																																																																										
VDDrip	Allowable VDD Ripple Voltage	-	-	500	[mV]	VDD= 5.0V, All white Pattern, Fv=75Hz																																																																																																										
Symbol	Description	Min	Typ	Max	Unit	Remark																																																																																																										
VDD	Power supply input voltage	4.5	5.0	5.5	[Volt]																																																																																																											
IDD	Power supply input Current (ave)	-	0.76	1.0	[A]	VDD= 5.0V, All white Pattern, Fv=60Hz																																																																																																										
		-	0.86	1.08	[A]	VDD= 5.0V, All white Pattern, Fv=75Hz																																																																																																										
PDD	VDD Power Consumption	-	3.8	5.0	[Watt]	VDD= 5.0V, All white Pattern, Fv=60Hz																																																																																																										
		-	4.3	5.4	[Watt]	VDD= 5.0V, All white Pattern, Fv=75Hz																																																																																																										
IRush	Inrush Current	-	-	3.0	[A]	Note 3-1																																																																																																										
VDDrip	Allowable VDD Ripple Voltage	-	-	500	[mV]	VDD= 5.0V, All white Pattern, Fv=75Hz																																																																																																										
1.3	2015/7/20	P6	<table border="1"> <tr> <td>Surface Treatment</td> <td>-</td> <td>Anti-Glare, 3H</td> </tr> </table>	Surface Treatment	-	Anti-Glare, 3H	<table border="1"> <tr> <td>Surface Treatment</td> <td>-</td> <td>SAG 26</td> </tr> </table>	Surface Treatment	-	SAG 26																																																																																																						
Surface Treatment	-	Anti-Glare, 3H																																																																																																														
Surface Treatment	-	SAG 26																																																																																																														

AUO Confidential for GO ARCHIVE Internal Use Only on 2015/7/27

晶 倉 庫

www.gotolcd.com

1 Handling Precautions

- 1) Since polarizer is easily damaged, do not touch or press the surface of polarizer with hand.
- 2) Wipe off water drop immediately. Long contact with water may cause discoloration or spots.
- 3) When the cell surface is soiled, wipe it with absorbent cotton or other soft cloth.
- 4) Since the cell is made of glass, it may break or crack if dropped or bumped on hard surface.
- 5) Since CMOS LSI is used in this module, take care of static electricity and insure human earth when handling.
- 6) Do not press or pat the panel surface by fingers, hand or tooling.
- 7) Please handle TFT cell with care. The FPCs can only sustain for quite limited stress.
- 8) The cell package tray is packed in clean room. Please do pack & unpack it in clean room.
- 9) At the insertion or removal of the Signal Interface Connector, be sure not to rotate nor tilt the Interface Connector of the TFT cell.
- 10) Pls avoid touching COF position while you are doing mechanical design.
- 11) When storing modules as spares for a long time, the following precaution is necessary: Store them in a dark place. Do not expose the module to sunlight or fluorescent light. Keep the temperature between 5°C and 35°C at normal humidity.
- 12) Do not apply the same pattern for a long time, it will enhance relevant defect.

2 General Description

This specification applies to the 23.8 inch wide Color a-Si TFT-LCD Module M238HVN01.2. The display supports the Full HD - 1920(H) x 1080(V) screen format and 16.7M colors (8-bit RGB data input). The input interface is Dual channel LVDS.

2.1 Display Characteristics

The following items are characteristics summary on the table under 25°C condition:

ITEMS	Unit	SPECIFICATIONS	
Screen Diagonal	[mm]	(23.8")	
Active Area	[mm]	527.04(H) x 296.46(V)	
Pixels H x V	-	1920(x3) x 1080	
Pixel Pitch	[um]	274.5 (per one triad) ×274.5	
Pixel Arrangement	-	R.G.B. Vertical Stripe	
Display Mode	-	VA Mode, Normally Black	
Response Time	[msec]	16 (Typ., on/off)	
Power Consumption	[Watt]	LCD module : PDD (Typ.)=3.8 @ White pattern,Fv=60Hz	
Weight	[Grams]	495.5 (Typ.)	
Electrical Interface	-	Dual channel LVDS , 8-bit RGB data input	
Support Color	-	16.7M colors	
Surface Treatment	-	SAG 2%	
Temperature Range	[°C]	0 to +50	
Operating Storage (Shipping)		-20 to +60	
Cell transmittance	[%]	4.37 (Typ.)	Base on AUO LED Backlight
		3.91 (Min.)	
Cell thickness	[mm]	1.36 (Thickness of polarizer film: 0.18 mm each side)	

2.2 Absolute Maximum Rating of Environment

Permanent damage may occur if exceeding the following maximum rating.

Symbol	Description	Min.	Max.	Unit	Remark
TOP	Operating Temperature	0	+50	[°C]	Note 2-1
TGS	Glass surface temperature (operation)	0	+65	[°C]	Note 2-1 Function judged only
HOP	Operation Humidity	5	90	[%RH]	Note 2-1
TST	Storage Temperature	-20	+60	[°C]	
HST	Storage Humidity	5	90	[%RH]	

Note 2-1: Temperature and relative humidity range are shown as the below figure.

1. 90% RH Max ($T_a \leq 39^\circ\text{C}$)
2. Max wet-bulb temperature at 39°C or less. ($T_a \leq 39^\circ\text{C}$)
3. No condensation

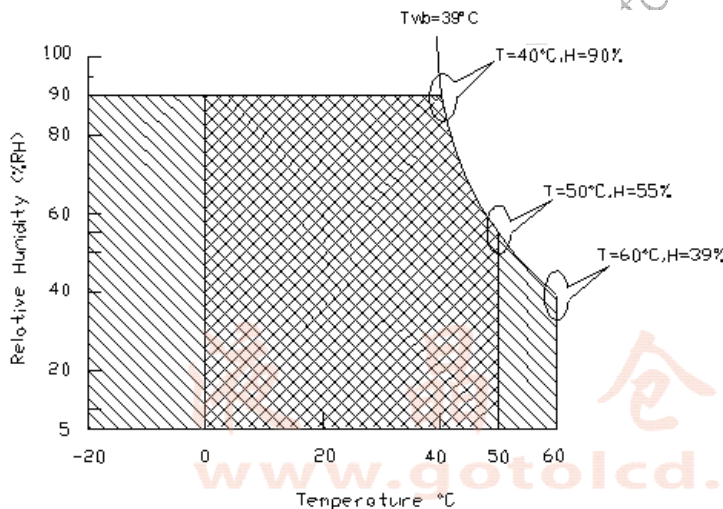

Operating Range



Storage Range

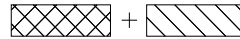

2.3 Optical Characteristics

The optical characteristics are measured on the following test condition.

Test Condition:

1. Equipment setup: Please refer to **Note 2-2**.
2. Panel Lighting time: 30 minutes
3. VDD=5.0V, Fv=60Hz, Is=70mA, Tα=25°C

Symbol	Description		Min	Typ.	Max	Unit	Remark
CR	Contrast Ratio (Center of screen)		1800	3000	-	-	Note 2-3 Base on AUO LED Backlight
θ_R	Horizontal Viewing Angle (CR=10)	Right	75	89	-	[degree]	Note 2-4 By SR-3
θ_L		Left	75	89	-		
Φ_H	Vertical Viewing Angle (CR=10)	Up	75	89	-		
Φ_L		Down	75	89	-		
θ_R	Horizontal Viewing Angle (CR=5)	Right	75	89	-		
θ_L		Left	75	89	-		
Φ_H	Vertical Viewing Angle (CR=5)	Up	75	89	-		
Φ_L		Down	75	89	-		
T_R	Response Time	Rising Time	-	10	20	[msec]	Note 2-5 By TRD-100
T_F		Falling Time	-	6	12		
-		Rising + Falling	-	16	32		
R_x	Color Coordinates (CIE 1931)	Red x	0.635	0.665	0.695	Base on C light	
R_y		Red y	0.293	0.323	0.353		
G_x		Green x	0.244	0.274	0.304		
G_y		Green y	0.561	0.591	0.621		
B_x		Blue x	0.106	0.136	0.166		
B_y		Blue y	0.095	0.125	0.155		
W_x		White x	0.263	0.293	0.323		
W_y		White y	0.320	0.350	0.380		
CT	Crosstalk		-	-	1.5	[%]	Note 2-6 By SR-3
F_{dB}	Flicker (Center of screen)		-	-	-20	[dB]	Note 2-7 By SR-3

Note 2-2: Equipment setup :

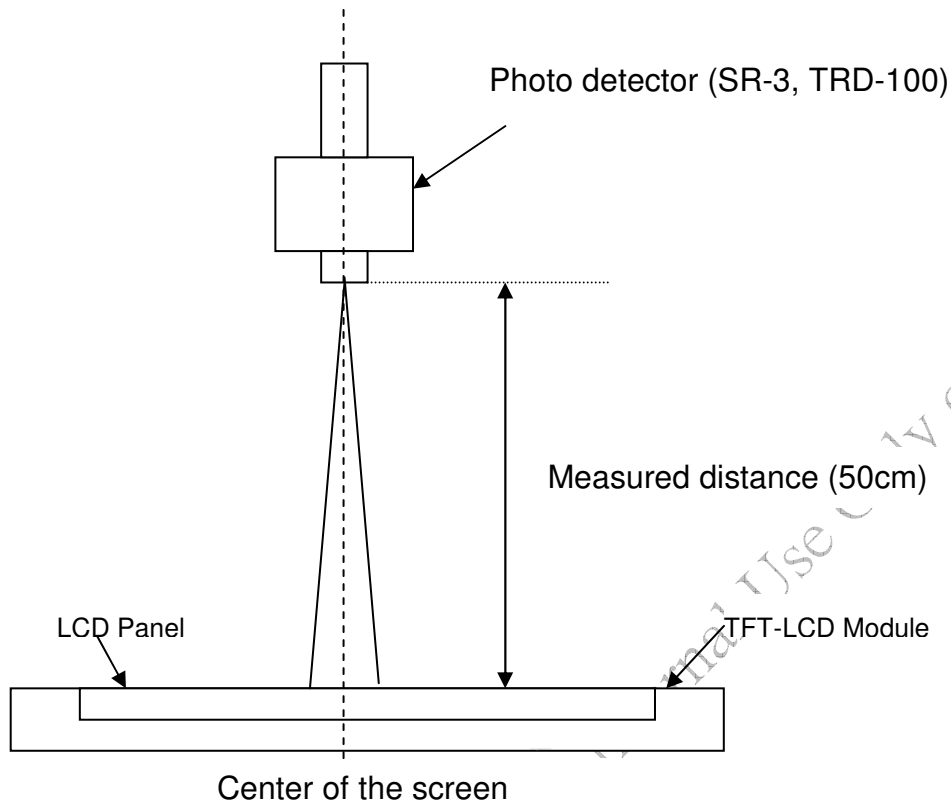

Note 2-3: Contrast Ratio Measurement

Definition:

$$\text{Contrast Ratio} = \frac{\text{Luminance of White pattern}}{\text{Luminance of Black pattern}}$$

a. Measured position: Center of screen (P5) & perpendicular to the screen

($\theta = \Phi = 0^\circ$)

Note 2-4: Viewing angle measurement

Definition: The angle at which the contrast ratio is greater than 10 & 5 .

a. Horizontal view angle: Divide to left & right (θ_L & θ_R)

Vertical view angle: Divide to up & down (Φ_H & Φ_L)

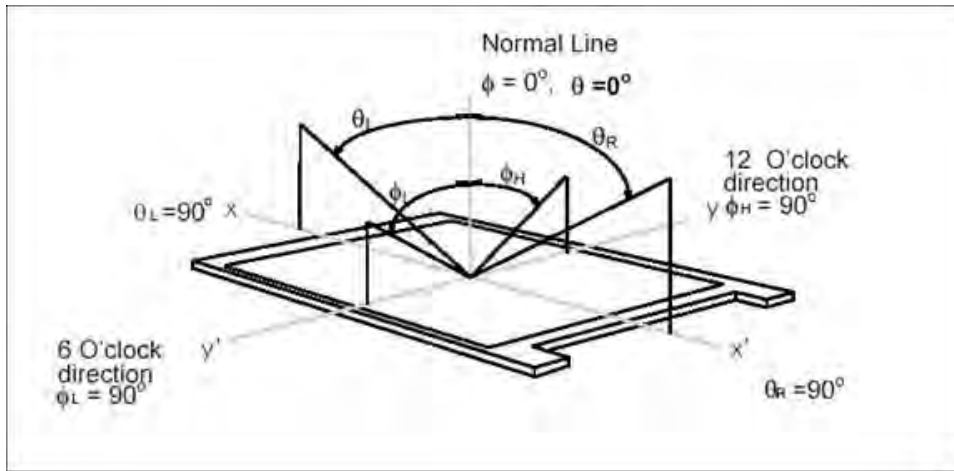

Note 2-5: Response time measurement

The output signals of photo detector are measured when the input signals are changed from "Black" to "White" (rising time, T_R), and from "White" to "Black" (falling time, T_F), respectively. The response time is interval between the 10% and 90% of optical response. (Black & White color definition: Please refer section 3.4.3)

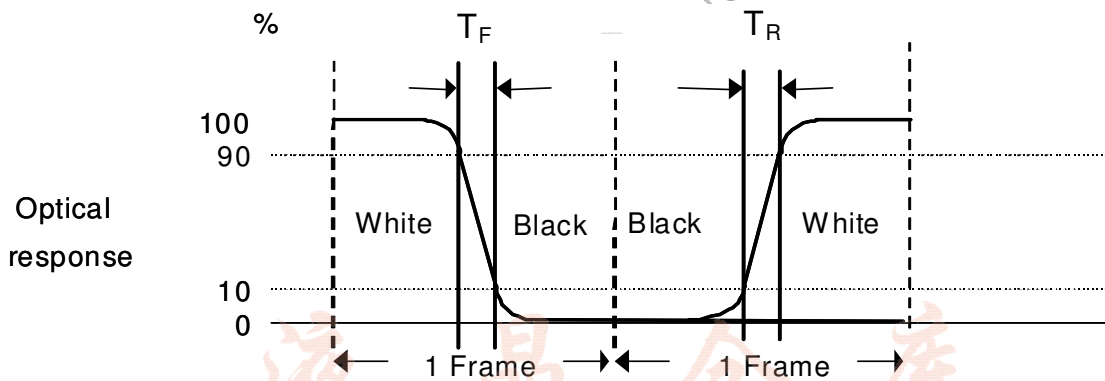

Note 2-6: Crosstalk measurement

Definition:

$$CT = \text{Max. } (CT_H, CT_V);$$

Where

a. Maximum Horizontal Crosstalk :

$$CT_H = \text{Max. } (| Y_{BL} - Y_{AL} | / Y_{AL} \times 100 \%, | Y_{BR} - Y_{AR} | / Y_{AR} \times 100 \%);$$

Maximum Vertical Crosstalk:

$$CT_V = \text{Max. } (| Y_{BU} - Y_{AU} | / Y_{AU} \times 100 \%, | Y_{BD} - Y_{AD} | / Y_{AD} \times 100 \%);$$

b. $Y_{AU}, Y_{AD}, Y_{AL}, Y_{AR}$ = Luminance of measured location without Black pattern

$Y_{BU}, Y_{BD}, Y_{BL}, Y_{BR}$ = Luminance of measured location with Black pattern

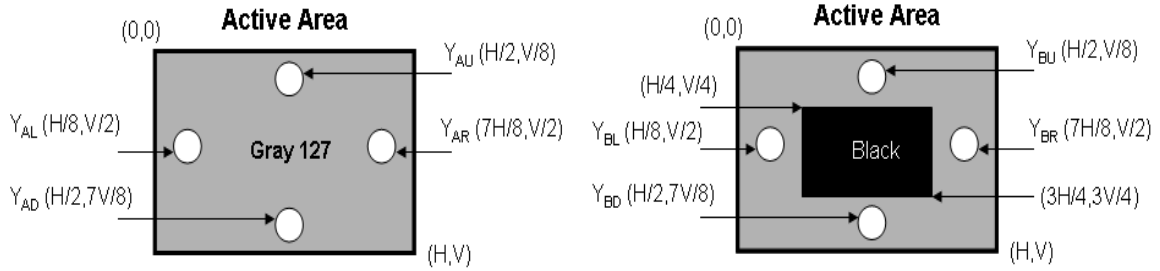

Note 2-7: Flicker measurement

a. Test pattern: It is listed as following.

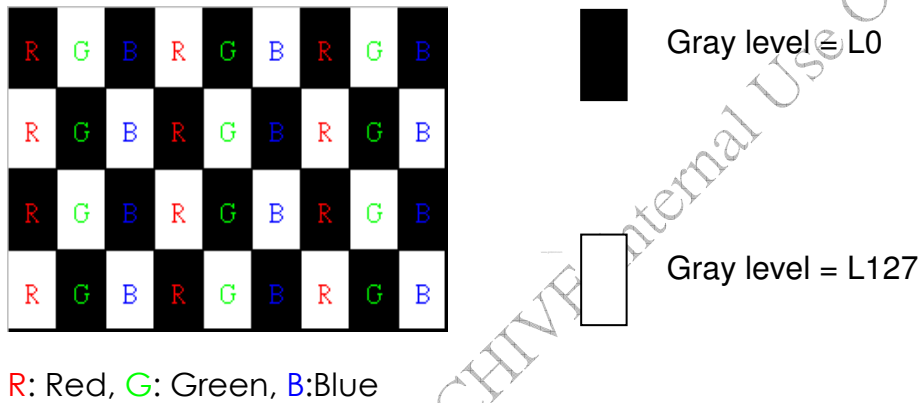

b. Measured position: Center of screen & perpendicular to the screen

3 TFT-LCD Module

3.1 Block Diagram

The following shows the block diagram of the 23.8 inch Color TFT-LCD Module.

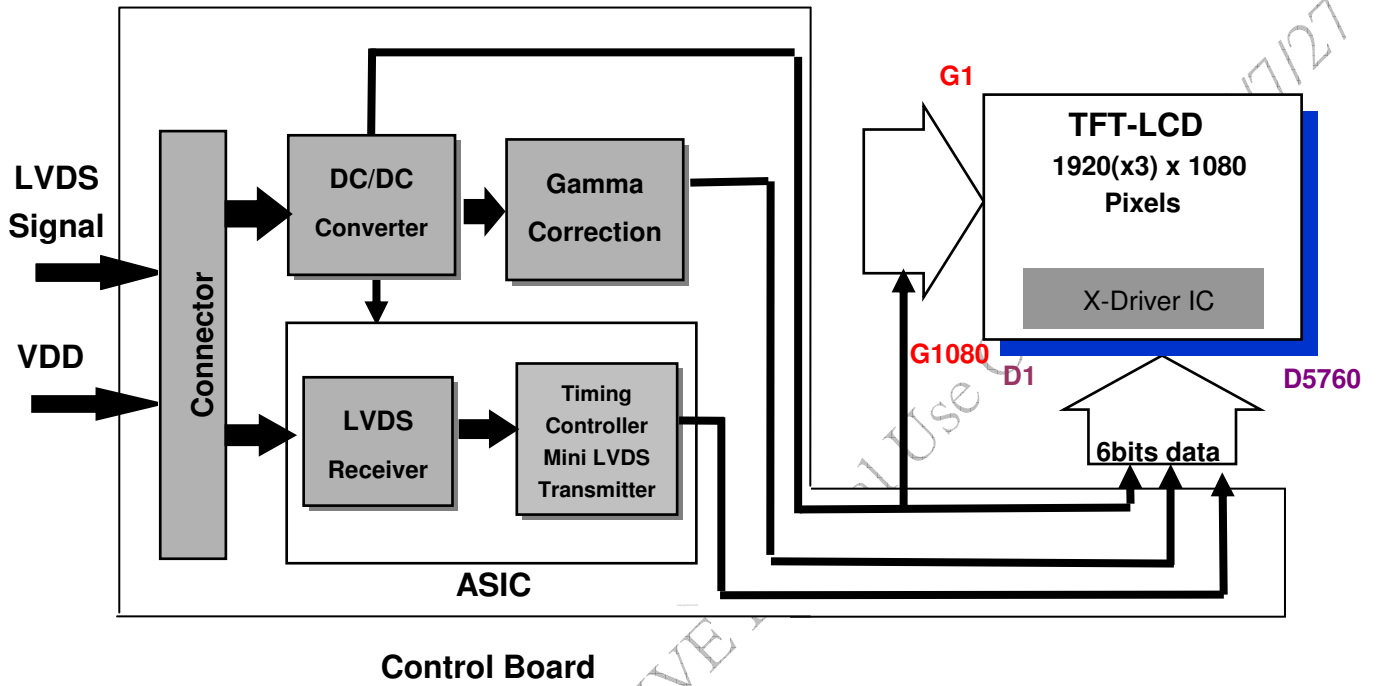

AUO Confidential for GO ARCHIVE
 液晶之家
 www.gotolcd.com

3.2 Interface Connection

3.2.1 Connector Type

TFT-LCD Connector	Manufacturer	P-TWO	STM
	Part Number	187034-3009	MSBKT2407P30HB
Mating Connector	Manufacturer	JAE or or Compatible	
	Part Number	FI-X30HL (Locked Type)	

3.2.2 Connector Pin Assignment

PIN #	Symbol	Description	Remark
1	RxO0-	Negative LVDS differential data input (Odd data)	
2	RxO0+	Positive LVDS differential data input (Odd data)	
3	RxO1-	Negative LVDS differential data input (Odd data)	
4	RxO1+	Positive LVDS differential data input (Odd data)	
5	RxO2-	Negative LVDS differential data input (Odd data)	
6	RxO2+	Positive LVDS differential data input (Odd data)	
7	GND	Ground	
8	RxOCLK-	Negative LVDS differential clock input (Odd clock)	
9	RxOCLK+	Positive LVDS differential clock input (Odd clock)	
10	RxO3-	Negative LVDS differential data input (Odd data)	
11	RxO3+	Positive LVDS differential data input (Odd data)	
12	RxE0-	Negative LVDS differential data input (Even data)	
13	RxE0+	Positive LVDS differential data input (Even data)	
14	GND	Ground	
15	RxE1-	Negative LVDS differential data input (Even data)	
16	RxE1+	Positive LVDS differential data input (Even data)	
17	GND	Ground	
18	RxE2-	Negative LVDS differential data input (Even data)	
19	RxE2+	Positive LVDS differential data input (Even data)	
20	RxECLK-	Negative LVDS differential clock input (Even clock)	
21	RxECLK+	Positive LVDS differential clock input (Even clock)	
22	RxE3-	Negative LVDS differential data input (Even data)	
23	RxE3+	Positive LVDS differential data input (Even data)	
24	GND	Must Connect to GND	
25	NC	No connection (for AUO test only. Do not connect)	
26	NC	No connection (for AUO test only. Do not connect)	

27	NC	No connection (for AUO test only. Do not connect)	
28	VDD	Power Supply Input Voltage	
29	VDD	Power Supply Input Voltage	
30	VDD	Power Supply Input Voltage	

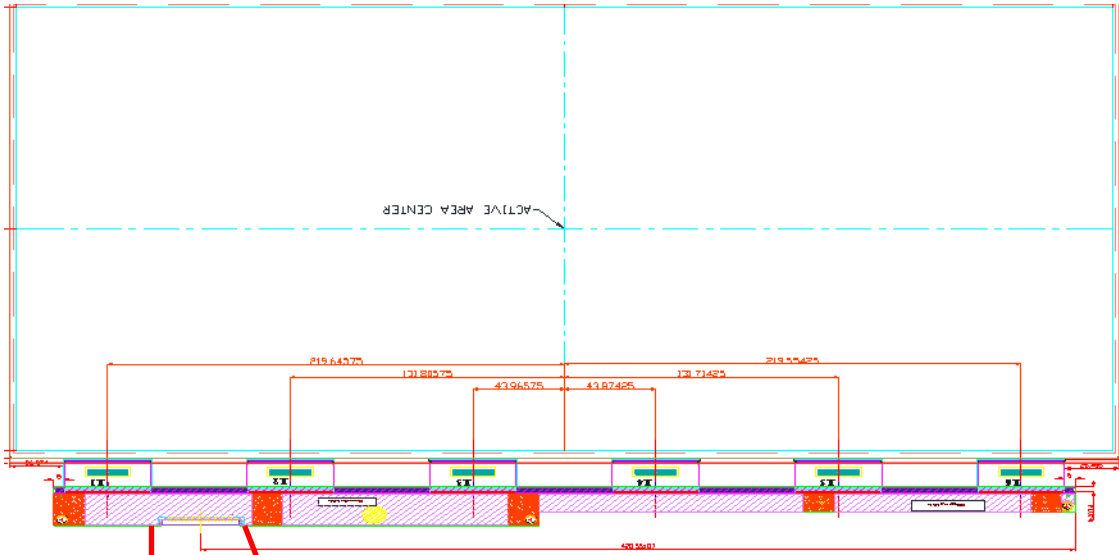

015/7/27

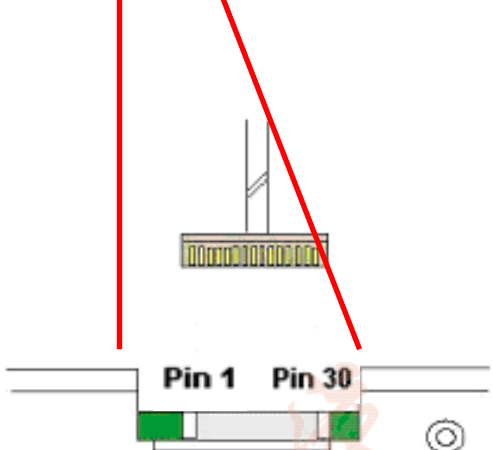

ACHIVE Inter

晶 包 庫
www.gotolcd.com

AUO Confidential

3.3 Electrical Characteristics

3.3.1 Absolute Maximum Rating

Permanent damage may occur if exceeding the following maximum rating.

Symbol	Description	Min	Max	Unit	Remark
VDD	Power Supply Input Voltage	GND-0.3	6.0	[Volt]	Ta=25°C

3.3.2 Recommended Operating Condition

Symbol	Description	Min	Typ	Max	Unit	Remark
VDD	Power supply Input voltage	4.5	5.0	5.5	[Volt]	
IDD	Power supply Input Current (RMS)	-	0.76	1.0	[A]	VDD= 5.0V, All white Pattern , Fv=60Hz
		-	0.86	1.08	[A]	VDD= 5.0V, All white Pattern , Fv=75Hz
PDD	VDD Power Consumption	-	3.8	5.0	[Watt]	VDD= 5.0V, All white Pattern , Fv=60Hz
		-	4.3	5.4	[Watt]	VDD= 5.0V, All white Pattern , Fv=75Hz
IRush	Inrush Current	-	-	3.0	[A]	Note 3-1
VDDrp	Allowable VDD Ripple Voltage	-	-	500	[mV]	VDD= 5.0V, All white Pattern , Fv=75Hz

Note 3-1: Inrush Current measurement:
Test circuit:

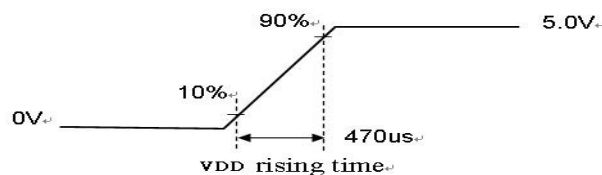
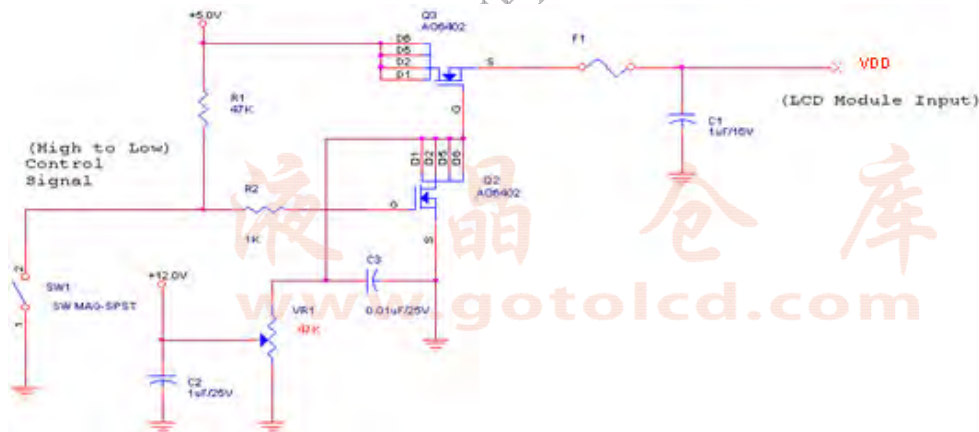

The duration of VDD rising time: 470us.

3.4 Signal Characteristics

3.4.1 LCD Pixel Format

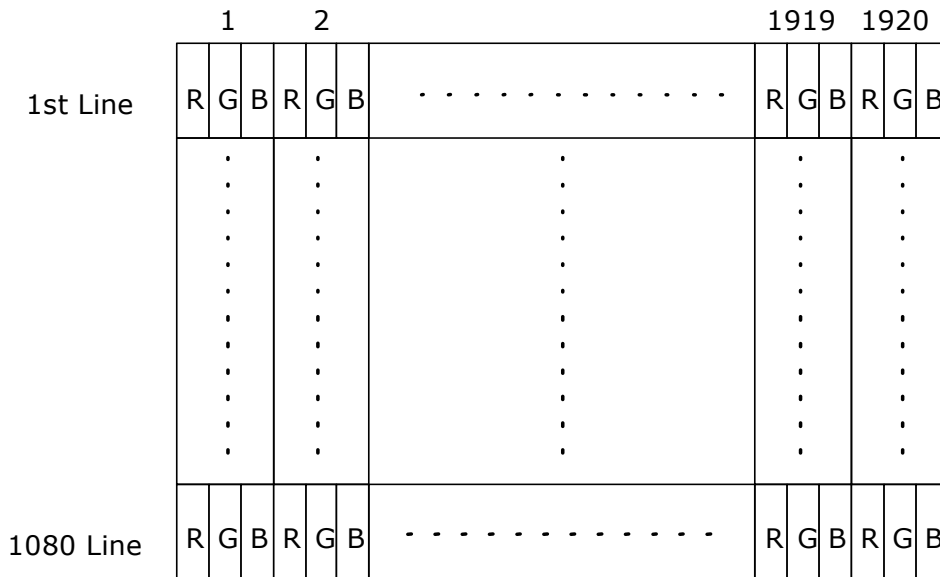

3.4.2 LVDS Data Format

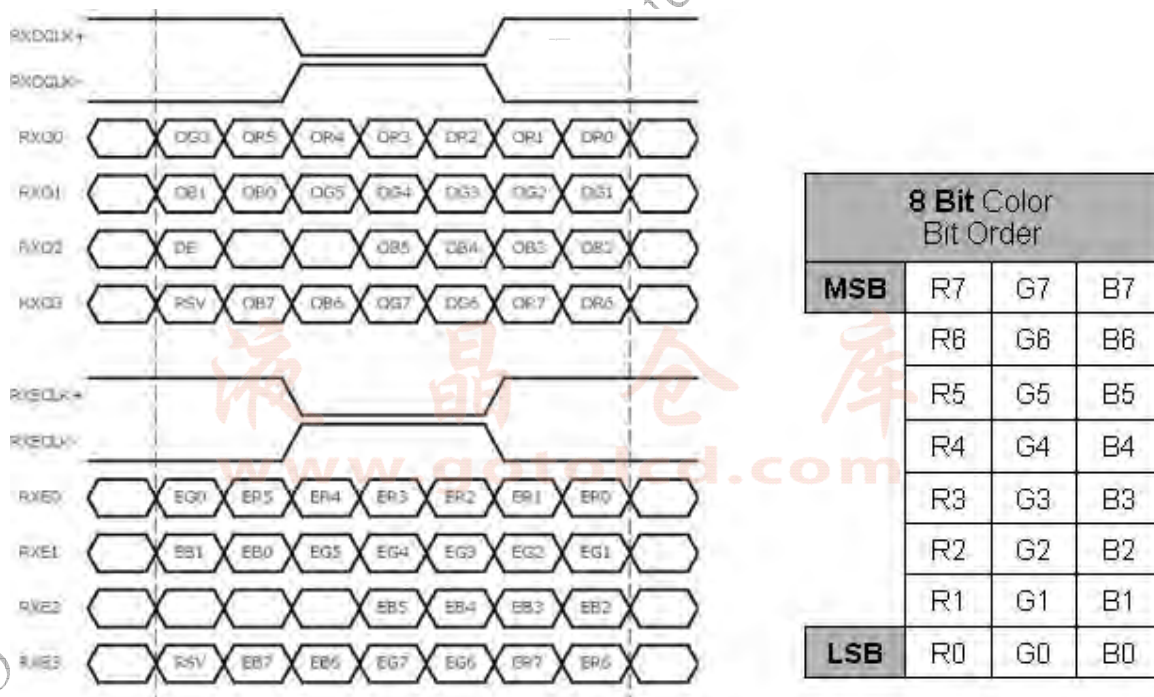

Note 3-2:

- a. O = "Odd Pixel Data" E = "Even Pixel Data"
- b. Refer to 3.4.1 LCD pixel format, the 1st data is 1 (Odd Pixel Data), the 2nd data is 2 (Even Pixel Data) and the last data is 1920 (Even Pixel Data).

3.4.3 Color versus Input Data

The following table is for color versus input data (8bit). The higher the gray level, the brighter the color.

Color	Gray Level	Color Input Data																				Remark				
		RED data (MSB:R7, LSB:R0)								GREEN data (MSB:G7, LSB:G0)								BLUE data (MSB:B7, LSB:B0)								
		R7	R6	R5	R4	R3	R2	R1	R0	G7	G6	G5	G4	G3	G2	G1	G0	B7	B6	B5	B4		B3	B2	B1	B0
Black	-	0	0	0	0	0	0	0	0	0	0	0	0	0	0	0	0	0	0	0	0	0	0	0	0	
White	-	1	1	1	1	1	1	1	1	1	1	1	1	1	1	1	1	1	1	1	1	1	1	1	1	
Gray 127	-	0	1	1	1	1	1	1	1	0	1	1	1	1	1	1	1	0	1	1	1	1	1	1	1	
Red	L0	0	0	0	0	0	0	0	0	0	0	0	0	0	0	0	0	0	0	0	0	0	0	0	0	Black
	:	:	:	:	:	:	:	:	:	:	:	:	:	:	:	:	:	:	:	:	:	:	:	:	:	
	L255	1	1	1	1	1	1	1	1	0	0	0	0	0	0	0	0	0	0	0	0	0	0	0	0	
Green	L0	0	0	0	0	0	0	0	0	0	0	0	0	0	0	0	0	0	0	0	0	0	0	0	0	Black
	:	:	:	:	:	:	:	:	:	:	:	:	:	:	:	:	:	:	:	:	:	:	:	:	:	
	L255	0	0	0	0	0	0	0	0	1	1	1	1	1	1	1	1	0	0	0	0	0	0	0	0	
Blue	L0	0	0	0	0	0	0	0	0	0	0	0	0	0	0	0	0	0	0	0	0	0	0	0	0	Black
	:	:	:	:	:	:	:	:	:	:	:	:	:	:	:	:	:	:	:	:	:	:	:	:	:	
	L255	0	0	0	0	0	0	0	0	0	0	0	0	0	0	0	0	1	1	1	1	1	1	1	1	

AUO Confidential for GO FPD
 晶 倉 庫
 www.gotolcd.com

3.4.4 LVDS Specification

a. DC Characteristics:

Symbol	Description	Min	Typ	Max	Units	Condition
V_{TH}	LVDS Differential Input High Threshold	-	-	+100	[mV]	$V_{CM} = 1.2V$
V_{TL}	LVDS Differential Input Low Threshold	-100	-	-	[mV]	$V_{CM} = 1.2V$
$ V_{ID} $	LVDS Differential Input Voltage	100	-	600	[mV]	
V_{CM}	LVDS Common Mode Voltage	+1.0	+1.2	+1.5	[V]	$V_{TH}-V_{TL} = 200mV$

LVDS Signal Waveform:

Use RxOCLK- & RxOCLK+ as example.

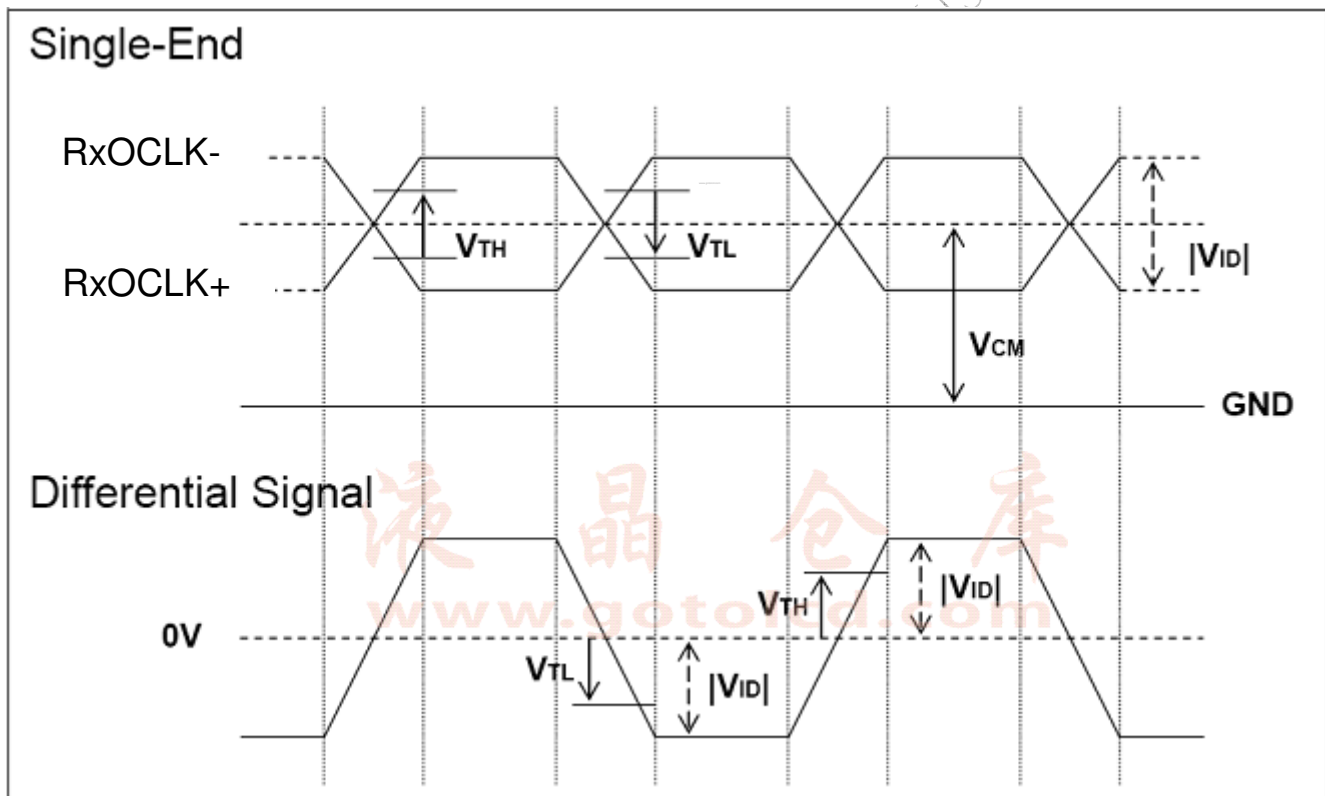

b. AC Characteristics:

Symbol	Description	Min	Max	Unit	Remark
F_{DEV}	Maximum deviation of input clock frequency during Spread Spectrum	-	± 3	%	
F_{MOD}	Maximum modulation frequency of input clock during Spread Spectrum	-	200	KHz	

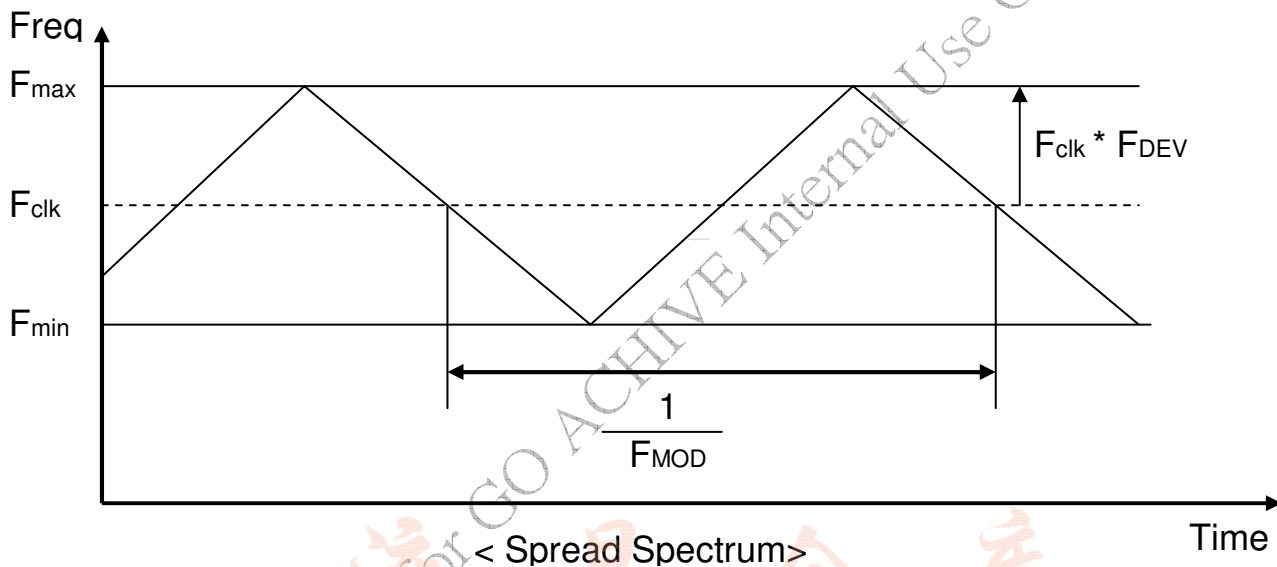

Fclk: LVDS Clock Frequency

3.4.5 Input Timing Specification

It only support DE mode, and the input timing are shown as the following table.

Symbol	Description		Min.	Typ.	Max.	Unit	Remark
Tv	Vertical Section	Period	1094	1130	1836	Th	
Tdisp (v)		Active	1080	1080	1080	Th	
Tblk (v)		Blanking	14	50	756	Th	
Fv		Frequency	49	60	76	Hz	
Th	Horizontal Section	Period	1000	1050	1678	Tclk	
Tdisp (h)		Active	960	960	960	Tclk	
Tblk (h)		Blanking	40	90	718	Tclk	
Fh		Frequency	53.7	67.8	90	KHz	Note 3-3
Tclk	LVDS Clock	Period	11.2	14.0	18.6	ns	1/Fclk
Fclk		Frequency	53.7	71.2	90.0	MHz	Note 3-4

Note 3-3: The equation is listed as following. Please don't exceed the above recommended value.

$$Fh (\text{Min.}) = Fclk (\text{Min.}) / Th (\text{Min.});$$

$$Fh (\text{Typ.}) = Fclk (\text{Typ.}) / Th (\text{Typ.});$$

$$Fh (\text{Max.}) = Fclk (\text{Max.}) / Th (\text{Min.});$$

Note 3-4: The equation is listed as following. Please don't exceed the above recommended value.

$$Fclk (\text{Min.}) = Fv (\text{Min.}) \times Th (\text{Min.}) \times Tv (\text{Min.});$$

$$Fclk (\text{Typ.}) = Fv (\text{Typ.}) \times Th (\text{Typ.}) \times Tv (\text{Typ.});$$

$$Fclk (\text{Max.}) = Fv (\text{Max.}) \times Th (\text{Typ.}) \times Tv (\text{Typ.});$$

3.4.6 Input Timing Diagram

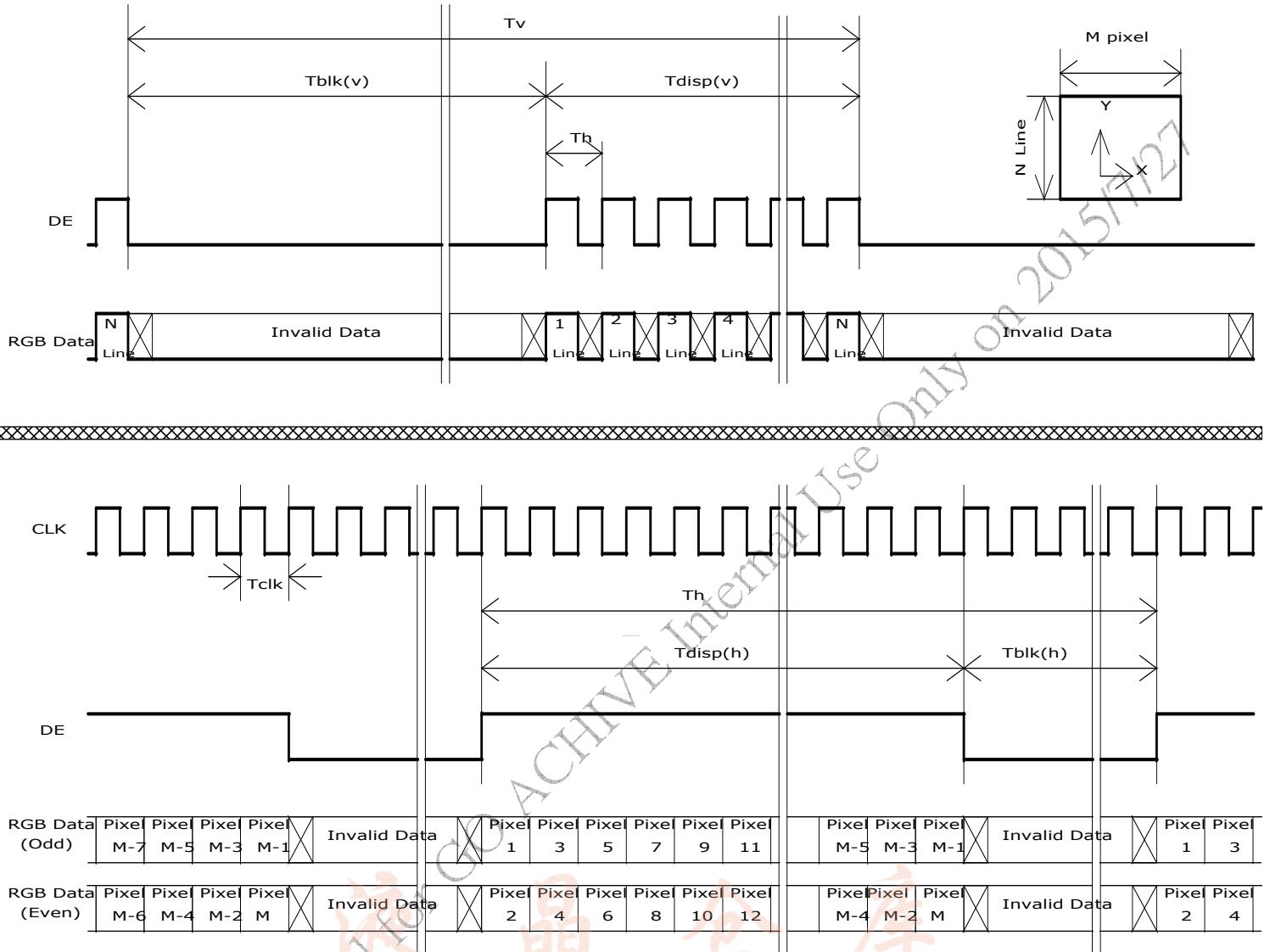

3.5 Power ON/OFF Sequence

VDD power, LVDS signal and backlight on/off sequence are as following. LVDS signals from any system shall be Hi-Z state when VDD is off.

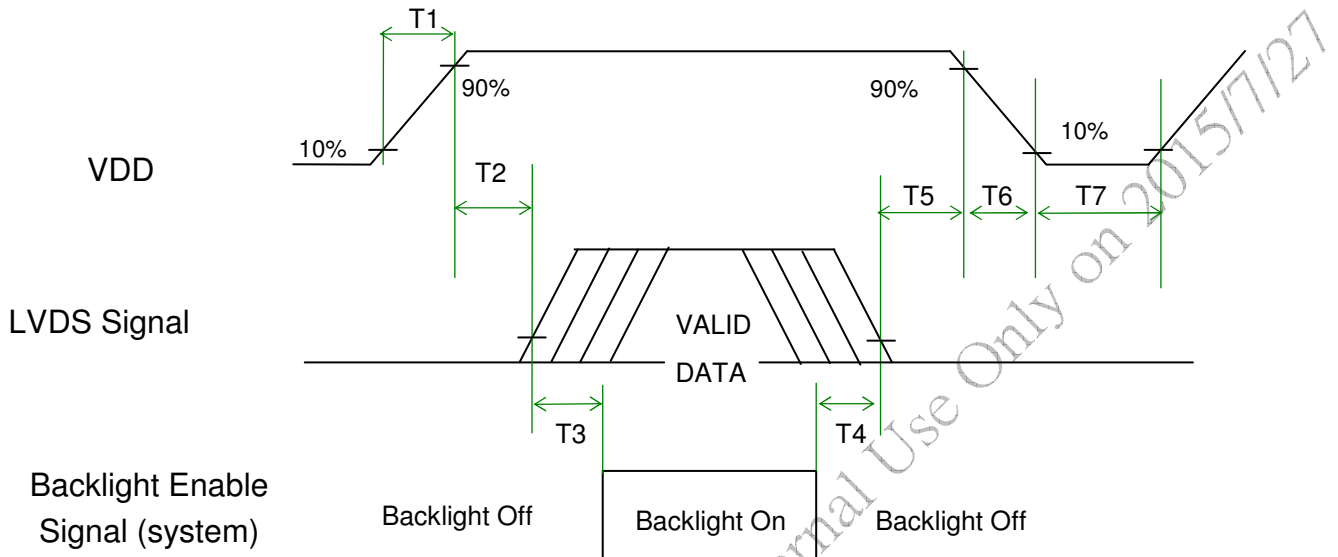

Power Sequence Timing

Symbol	Value			Unit	Remark
	Min.	Typ.	Max.		
T1	0.5	-	10	[ms]	
T2	0	-	50	[ms]	
T3	500	-	-	[ms]	
T4	100	-	-	[ms]	
T5	0	-	50	[ms]	Note 3-5 Note 3-6
T6	0	-	200	[ms]	Note 3-6 Note 3-7
T7	1000	-	-	[ms]	

Note 3-5 : Recommend setting T5 = 0ms to avoid electronic noise when VDD is off.

Note 3-6 : During T5 period , please keep the level of input LVDS signals with Hi-Z state.

Note 3-7 : Voltage of VDO must decay smoothly after power-off. (customer system decide this value)

4 Reliability Test

AUO reliability test items are listed as following table. (Bare Panel only)

Items	Condition	Remark
Temperature Humidity Bias (THB)	Ta= 50°C , 80%RH, 300hours	
High Temperature Operation (HTO)	Ta= 50°C , 50%RH, 300hours	
Low Temperature Operation (LTO)	Ta= 0°C , 300hours	
High Temperature Storage (HTS)	Ta= 60°C , 300hours	
Low Temperature Storage (LTS)	Ta= -20°C , 300hours	
Thermal Shock Test (TST)	-20°C /30min, 60°C /30min, 100 cycles	Note 4-1

- Note 4-1:**
- A cycle of rapid temperature change consists of varying the temperature from -20°C to 60°C, and back again. Power is not applied during the test.
 - After finish temperature cycling, the unit is placed in normal room ambient for at least 4 hours before power on.

5 Shipping Label

5.1 Small Shipping Label

The label is on the PCBA as shown below :



5.2 Run Card Label

The label is on the panel as shown below :

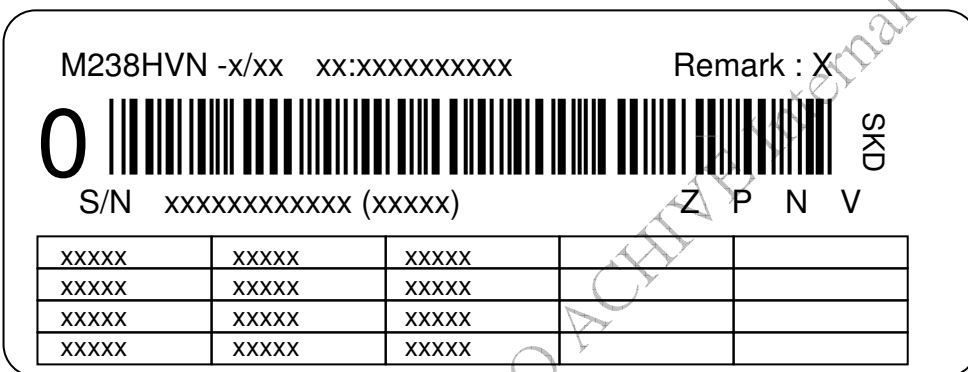

6 Mechanical Characteristic

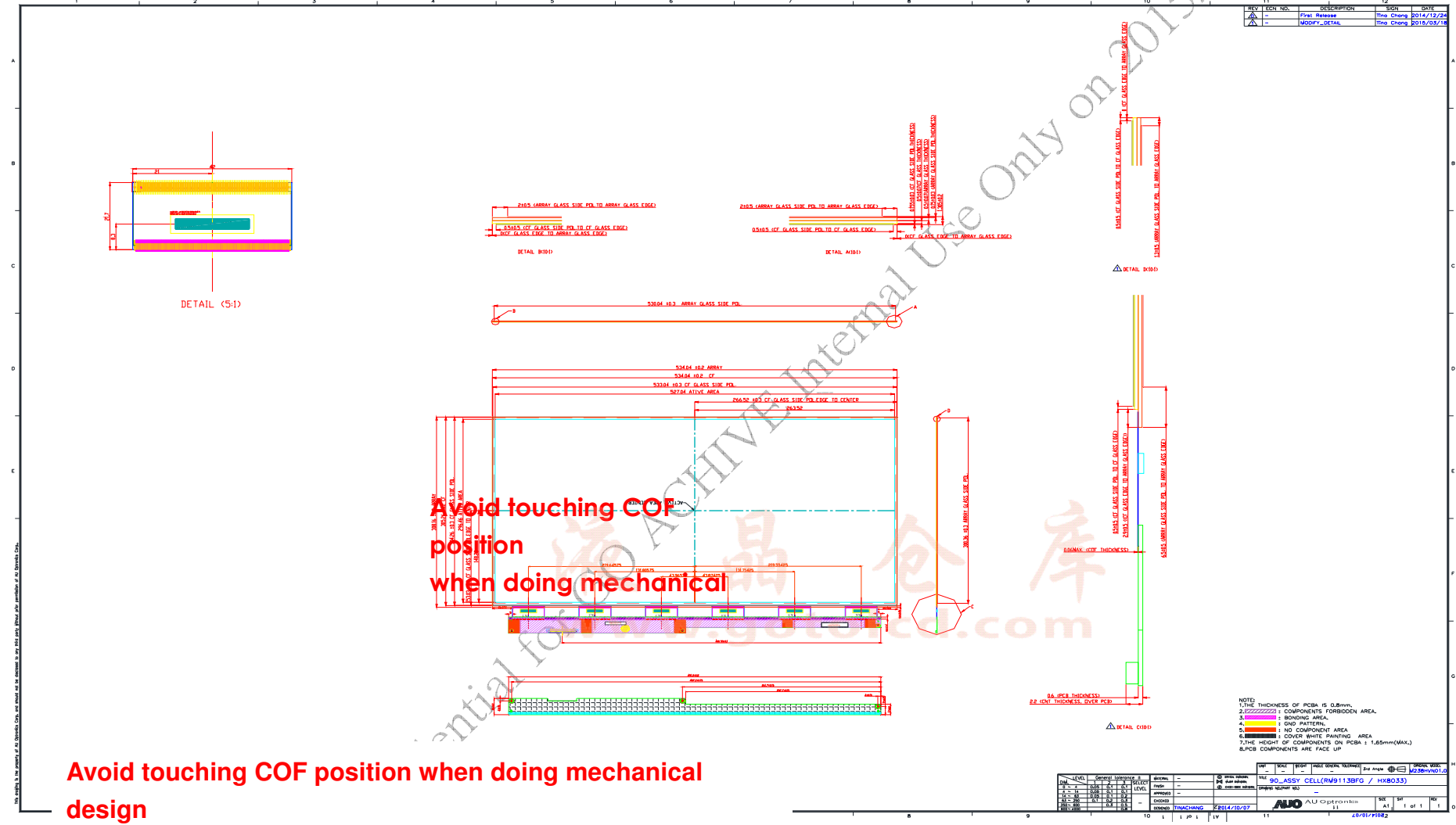

7 Packing Specification

7.1 Packing Flow

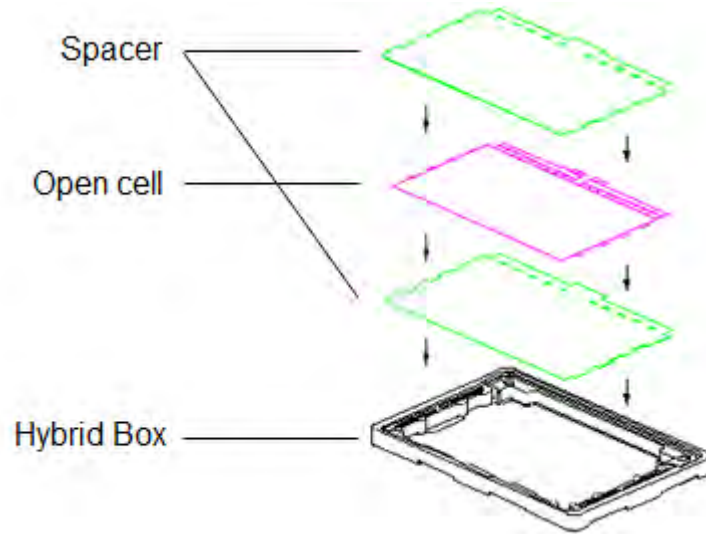

- Open cell : 20 (pcs/Box)
- Spacer : 21 (pcs/Box)

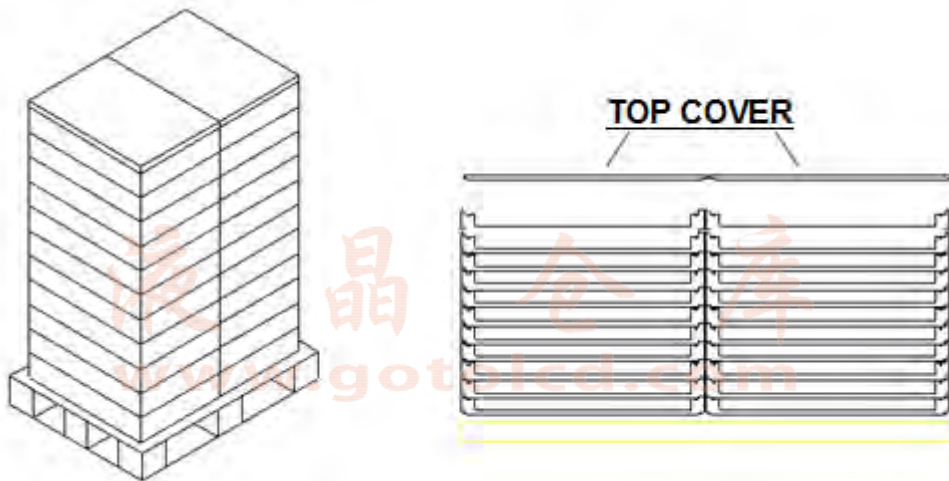

- 2 (Box/Layer)
- 11 (Layer/Pallet)

單層 pallet 打棧示意圖 Single pallet packaging illustration

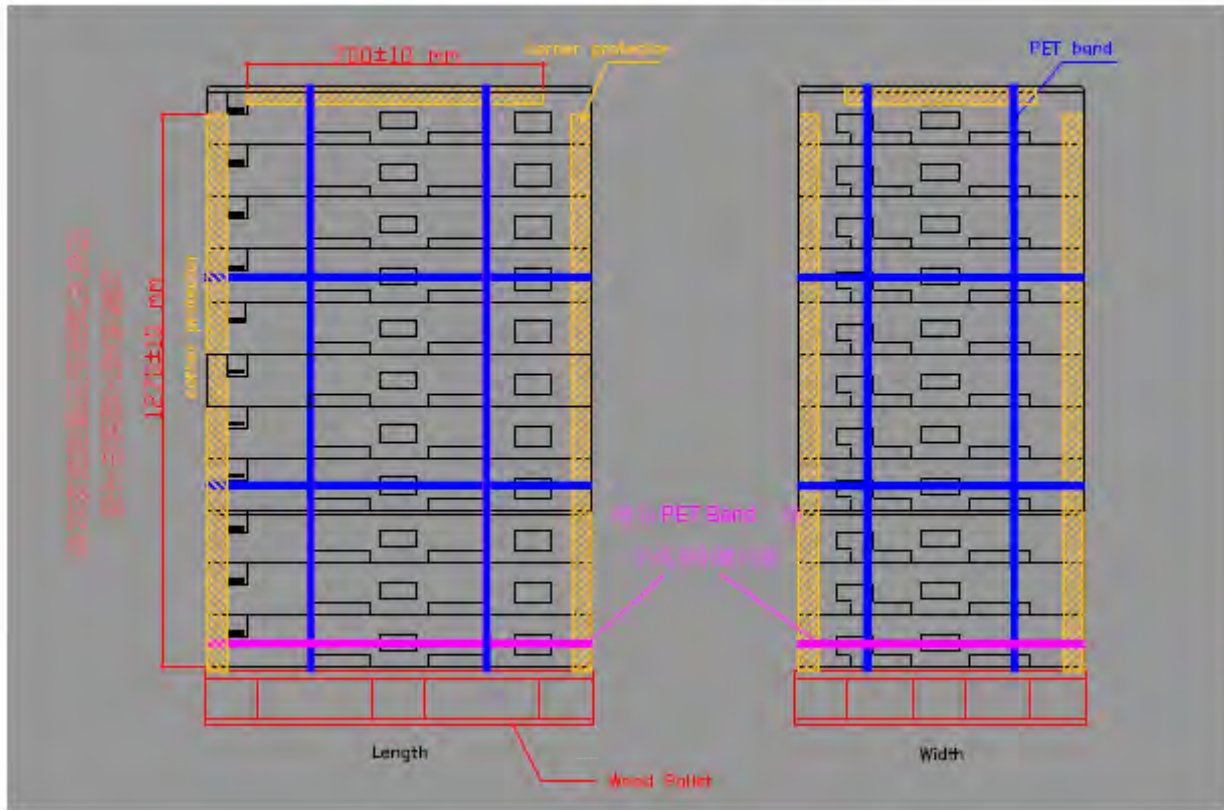

7.2 Pallet and Shipment information

Item	Specification			Remark
	Q'ty	Dimension	Weight(kg)	
Box	1	716(L)mm x 478(W)mm x 127.5(H)mm	0.65	without cell & spacer
Packing Box	20 pcs/Box	716(L)mm x 478(W)mm x 127.5(H)mm	11	with cell & cushion & spacer
Pallet	22	980(L)mm x 740(W)mm x 132(H)mm	12.0	
Pallet after Packing	22 boxes/pallet	980(L)mm x 740(W)mm x 1454.5(H)mm	254	