





TFT LCD Preliminary Specification

MODEL NO.: M240J1- L01

Customer: (Preliminary Specification Reference Only)

Approved by: _____

Note:

| Liquid Crystal Display Division | |
|---|---|
| QRA Division. | OA Head Division. |
| Approval | Approval |
|  |  |

- CONTENTS -

| | | |
|---|-------|----|
| REVISION HISTORY | ----- | 3 |
| 1. GENERAL DESCRIPTION | ----- | 4 |
| 1.1 OVERVIEW | | |
| 1.2 FEATURES | | |
| 1.3 APPLICATION | | |
| 1.4 GENERAL SPECIFICATIONS | | |
| 1.5 MECHANICAL SPECIFICATIONS | | |
| 2. ABSOLUTE MAXIMUM RATINGS | ----- | 5 |
| 2.1 ABSOLUTE RATINGS OF ENVIRONMENT | | |
| 2.2 ELECTRICAL ABSOLUTE RATINGS | | |
| 2.2.1 TFT LCD MODULE | | |
| 2.2.2 BACKLIGHT UNIT | | |
| 3. ELECTRICAL CHARACTERISTICS | ----- | 7 |
| 3.1 TFT LCD MODULE | | |
| 3.2 BACKLIGHT UNIT | | |
| 4. BLOCK DIAGRAM | ----- | 11 |
| 4.1 TFT LCD MODULE | | |
| 4.2 BACKLIGHT UNIT | | |
| 5. INPUT TERMINAL PIN ASSIGNMENT | ----- | 12 |
| 5.1 TFT LCD MODULE | | |
| 5.2 BACKLIGHT UNIT | | |
| 5.3 TIMING DIAGRAM OF LVDS INPUT SIGNAL | | |
| 5.4 COLOR DATA INPUT ASSIGNMENT | | |
| 6. INTERFACE TIMING | ----- | 15 |
| 6.1 INPUT SIGNAL TIMING SPECIFICATIONS | | |
| 6.2 POWER ON/OFF SEQUENCE | | |
| 7. OPTICAL CHARACTERISTICS | ----- | 17 |
| 7.1 TEST CONDITIONS | | |
| 7.2 OPTICAL SPECIFICATIONS | | |
| 8. PACKAGING | ----- | 21 |
| 8.1 PACKING SPECIFICATIONS | | |
| 8.2 PACKING METHOD | | |
| 9. DEFINITION OF LABELS | ----- | 23 |
| 10. PRECAUTIONS | ----- | 24 |
| 10.1 ASSEMBLY AND HANDLING PRECAUTIONS | | |
| 10.2 SAFETY PRECAUTIONS | | |
| 11. MECHANICAL CHARACTERISTICS | ----- | 25 |

REVISION HISTORY

| Version | Date | Section | Description |
|----------------|--------------|----------------|--|
| Ver 1.0 | Sep, 05, 05' | All | M240J1 -L01 Specifications was first issued. |

1. GENERAL DESCRIPTION

1.1 OVERVIEW

M240J1 -L01 is an 24.0" TFT Liquid Crystal Display module with 6 CCFL Backlight unit and 30 pins 2ch-LVDS interface. This module supports 1920 x 1200 WUXGA mode and can display up to 16.7M colors. The inverter module for Backlight is not built in.

1.2 FEATURES

- Super MVA extra-wide viewing angle.
- High contrast ratio
- Fast response time
- High color saturation
- WUXGA (1920 x 1200 pixels) resolution
- DE (Data Enable) only mode
- LVDS (Low Voltage Differential Signaling) interface
- RoHS compliance

1.3 APPLICATION

- TFT LCD Monitor

1.4 GENERAL SPECIFICATIONS

| Item | Specification | Unit | Note |
|--------------------|---|-------|------|
| Active Area | 518.4 (H) x 324 (V) (24.0" diagonal) | mm | (1) |
| Bezel Opening Area | 522.4 (H) x 328.0 (V) | mm | |
| Driver Element | a-si TFT active matrix | - | - |
| Pixel Number | 1920 x R.G.B. x 1200 | pixel | - |
| Pixel Pitch | 0.270 (H) x 0.270 (V) | mm | - |
| Pixel Arrangement | RGB vertical stripe | - | - |
| Display Colors | 16.7M | color | - |
| Transmissive Mode | Normally black | - | - |
| Surface Treatment | Hard coating (3H), Anti-glare (Haze 25) | - | - |

1.5 MECHANICAL SPECIFICATIONS

| Item | Min. | Typ. | Max. | Unit | Note | |
|-------------|---------------|-------|-------|-------|------|-----|
| Module Size | Horizontal(H) | 545.9 | 546.4 | 546.9 | mm | (1) |
| | Vertical(V) | 351.5 | 352.0 | 352.5 | mm | |
| | Depth(D) | | 34.8 | 35.3 | mm | |
| Weight | - | | TBD | g | - | |

Note (1) Please refer to the attached drawings for more information of front and back outline dimensions.

2. ABSOLUTE MAXIMUM RATINGS

2.1 ABSOLUTE RATINGS OF ENVIRONMENT

| Item | Symbol | Value | | Unit | Note |
|-------------------------------|------------------|-------|------|------|----------|
| | | Min. | Max. | | |
| Storage Temperature | T _{ST} | -20 | +60 | °C | (1) |
| Operating Ambient Temperature | T _{OP} | 0 | +50 | °C | (1), (2) |
| Shock (Non-Operating) | S _{NOP} | - | 50 | G | (3), (5) |
| Vibration (Non-Operating) | V _{NOP} | - | 1.5 | G | (4), (5) |

Note (1) Temperature and relative humidity range is shown in the figure below.

(a) 90 %RH Max. ($T_a \leq 40$ °C).

(b) Wet-bulb temperature should be 39 °C Max. ($T_a > 40$ °C).

(c) No condensation.

Note (2) The temperature of panel display surface area should be 0 °C Min. and 60 °C Max.

Note (3) 11ms, half sine wave, 1 time for $\pm X$, $\pm Y$, $\pm Z$.

Note (4) 10 ~ 300 Hz, 10min/cycle, 3 cycles each X, Y, Z.

Note (5) At testing Vibration and Shock, the fixture in holding the module has to be hard and rigid enough so that the module would not be twisted or bent by the fixture.

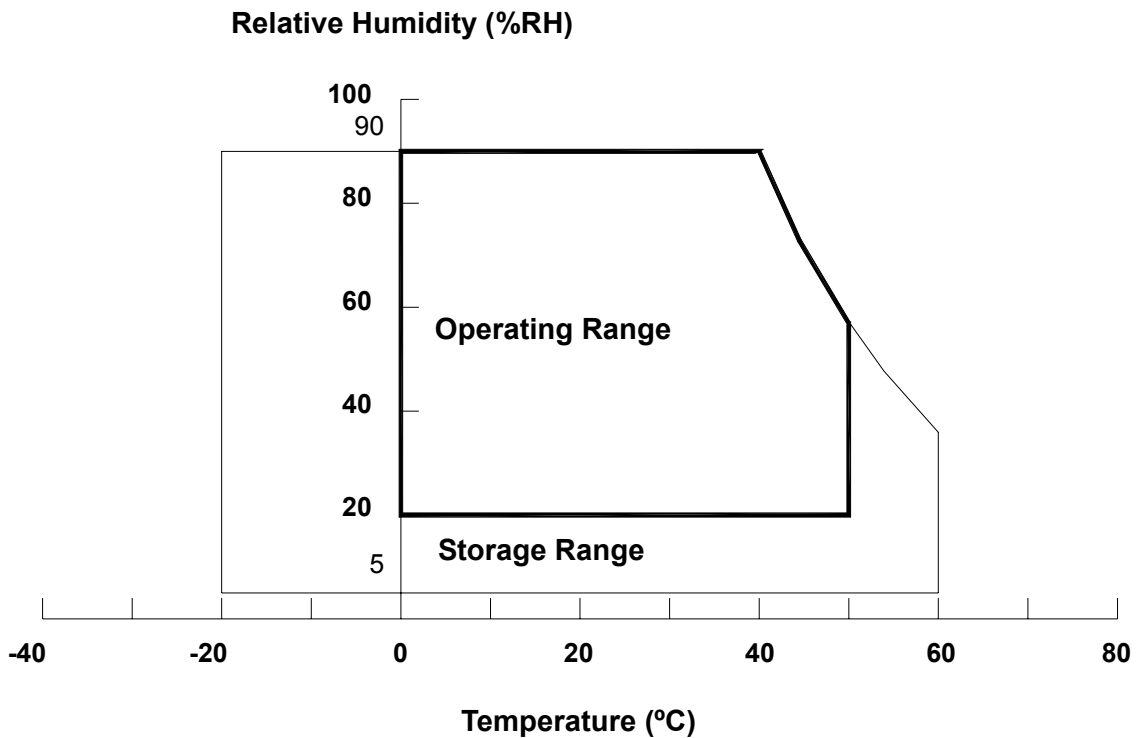

2.2 ELECTRICAL ABSOLUTE RATINGS

2.2.1 TFT LCD MODULE

| Item | Symbol | Value | | Unit | Note |
|----------------------|-----------------|-------|------|------|------|
| | | Min. | Max. | | |
| Power Supply Voltage | V _{CC} | -0.3 | +6.0 | V | (1) |
| Logic Input Voltage | V _{IN} | -0.3 | 4.3 | V | |

2.2.2 BACKLIGHT UNIT

| Item | Symbol | Value | | Unit | Note |
|----------------|----------------|-------|------|-------------------|----------------------------------|
| | | Min. | Max. | | |
| Lamp Voltage | V _L | - | 2.5K | V _{RMS} | (1), (2), I _L = 6.5mA |
| Lamp Current | I _L | - | 7.0 | mA _{RMS} | |
| Lamp Frequency | F _L | - | 80 | KHz | (1), (2) |

Note (1) Permanent damage to the device may occur if maximum values are exceeded. Function operation should be restricted to the conditions described under Normal Operating Conditions.

Note (2) Specified values are for lamp (Refer to 3.2 for further information).

3. ELECTRICAL CHARACTERISTICS

3.1 TFT LCD MODULE

Ta = 25 ± 2 °C

| Parameter | Symbol | Value | | | Unit | Note |
|---------------------------------|-------------------|-----------------|-------|-------|------|------|
| | | Min. | Typ. | Max. | | |
| Power Supply Voltage | V _{CC} | 4.5 | 5.0 | 5.5 | V | - |
| Ripple Voltage | V _{RP} | - | - | 100 | mV | - |
| Rush Current | I _{RUSH} | - | (2) | (4) | A | (2) |
| Power Supply Current | White | - | (1.3) | (2.2) | mA | (3)a |
| | Black | - | (1.0) | (1.7) | mA | (3)b |
| | Vertical Stripe | - | (1.5) | (2.6) | mA | (3)c |
| LVDS differential input voltage | V _{id} | 100 | - | 600 | mV | |
| LVDS common input voltage | V _{ic} | - | 1.2 | - | V | |
| Logic "L" input voltage | V _{il} | V _{SS} | - | 0.8 | V | |

Note (1) The module should be always operated within above ranges.

Note (2) Measurement Conditions:

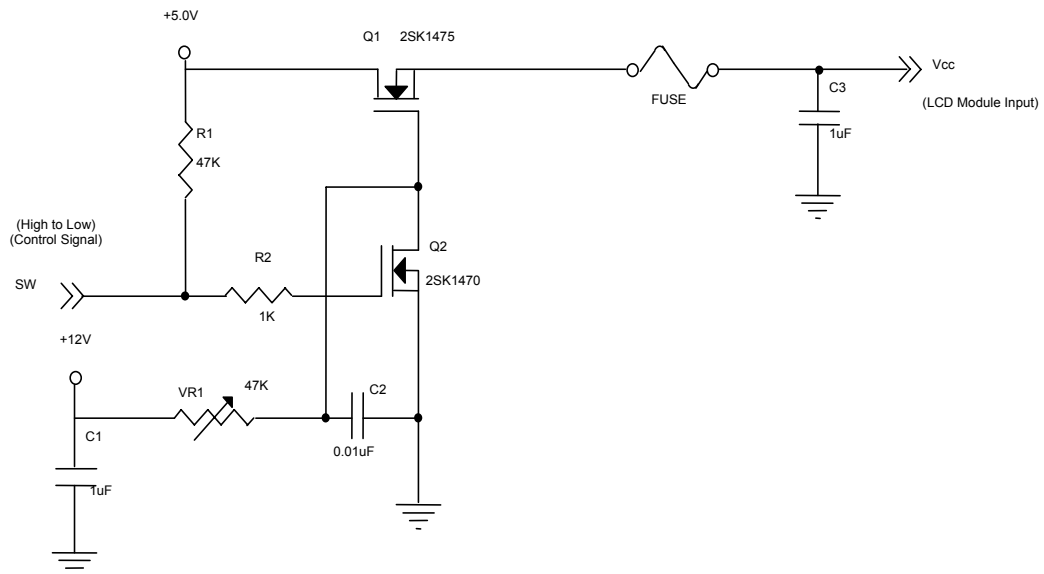

Vcc rising time is 470μs

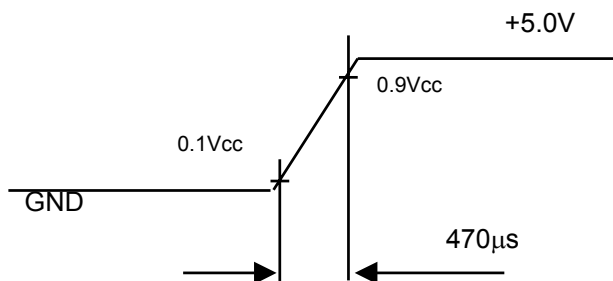

Note (3) The specified power supply current is under the conditions at $V_{cc} = 5.0\text{ V}$, $T_a = 25 \pm 2\text{ }^\circ\text{C}$, $f_v = 60\text{ Hz}$, whereas a power dissipation check pattern below is displayed.

a. White Pattern



Active Area

b. Black Pattern



Active Area

c. Vertical Stripe Pattern

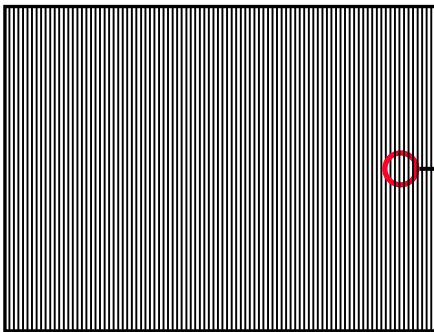

Active Area

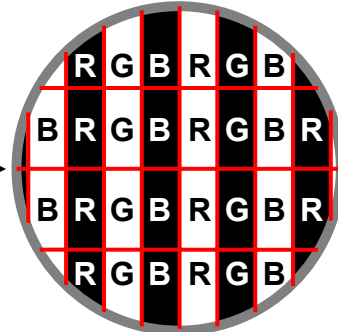

3.2 BACKLIGHT UNIT

Ta = 25 ± 2 °C

| Parameter | Symbol | Value | | | Unit | Note |
|----------------------|-----------------|--------|--------|-------------|-------------------|------------------------------|
| | | Min. | Typ. | Max. | | |
| Lamp Input Voltage | V _L | TBD | (1830) | TBD | V _{RMS} | I _L = 5.3 mA |
| Lamp Current | I _L | TBD | (5.3) | TBD | mA _{RMS} | (1) |
| Lamp Turn On Voltage | V _s | --- | --- | TBD (25 °C) | V _{RMS} | (2) |
| | | --- | --- | TBD (0 °C) | V _{RMS} | (2) |
| Operating Frequency | F _L | TBD | --- | TBD | KHz | (3) |
| Lamp Life Time | L _{BL} | 50,000 | --- | --- | Hrs | (5) |
| Power Consumption | P _L | --- | (58.2) | --- | W | (4), I _L = 5.3 mA |

Note (1) Lamp current is measured by current amplify & oscilloscope as shown below:

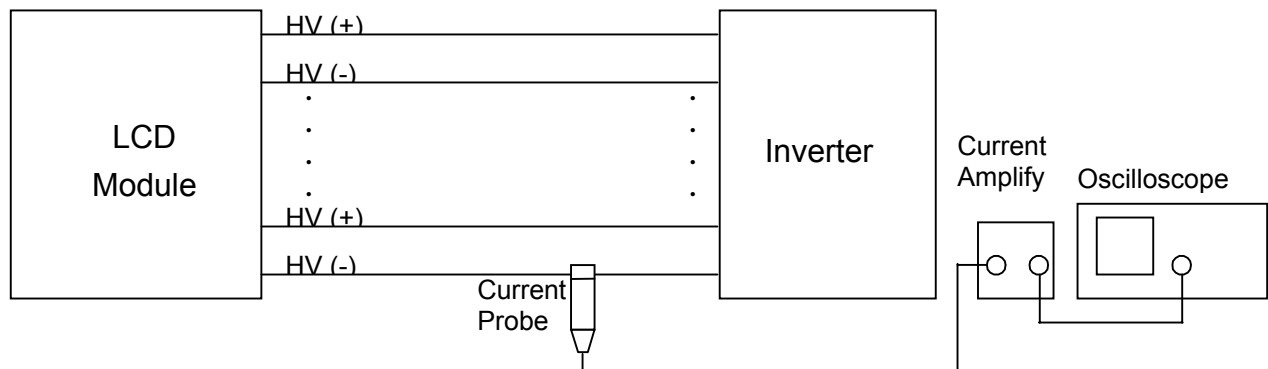

Measure equipment:
 Current Amplify: Tektronix TCPA300
 Current probe: Tektronix TCP312
 Oscilloscope: TDS3054B

Note (2) The voltage shown above should be applied to the lamp for more than 1 second after startup. Otherwise, the lamp may not be turned on normally.

Note (3) The lamp frequency may produce interference with horizontal synchronization frequency from the display, which might cause line flow on the display. In order to avoid interference, the lamp frequency should be detached from the horizontal synchronization frequency and its harmonics as far as possible.

Note (4) $P_L = I_L \times V_L \times 6$

Note (5) The lifetime of lamp can be defined as the time in which it continues to operate under the condition Ta = 25 ± 2 °C and I_L = 2.0 ~ 5.5 mA_{RMS} until one of the following events occurs:

- (a) When the brightness becomes or lower than 50% of its original value.
- (b) When the effective ignition length becomes or lower than 80% of its original value. (Effective ignition length is defined as an area that has less than 70% brightness compared to the brightness in the center point.)

Note (6) The waveform of the voltage output of inverter must be area-symmetric and the design of the inverter must have specifications for the modularized lamp. The performance of the Backlight, such as lifetime or brightness, is greatly influenced by the characteristics of the DC-AC inverter for the lamp. All the parameters of an inverter should be carefully designed to avoid producing too

much current leakage from high voltage output of the inverter. When designing or ordering the inverter please make sure that a poor lighting caused by the mismatch of the Backlight and the inverter (miss-lighting, flicker, etc.) never occurs. If the above situation is confirmed, the module should be operated in the same manners when it is installed in your instrument.

The output of the inverter must have symmetrical (negative and positive) voltage waveform and symmetrical current waveform. (Unsymmetrical ratio is less than 10%) Please do not use the inverter which has unsymmetrical voltage and unsymmetrical current and spike wave. Lamp frequency may produce interface with horizontal synchronous frequency and as a result this may cause beat on the display. Therefore lamp frequency shall be as away possible from the horizontal synchronous frequency and from its harmonics in order to prevent interference.

Requirements for a system inverter design, which is intended to have a better display performance, a better power efficiency and a more reliable lamp. It shall help increase the lamp lifetime and reduce its leakage current.

- a. The asymmetry rate of the inverter waveform should be 10% below;
- b. The distortion rate of the waveform should be within $\sqrt{2} \pm 10\%$;
- c. The ideal sine wave form shall be symmetric in positive and negative polarities

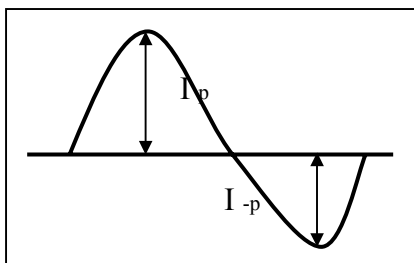

* Asymmetry rate:

$$| I_p - I_{-p} | / I_{rms} * 100\%$$

* Distortion rate

$$I_p \text{ (or } I_{-p}) / I_{rms}$$

4. BLOCK DIAGRAM

4.1 TFT LCD MODULE

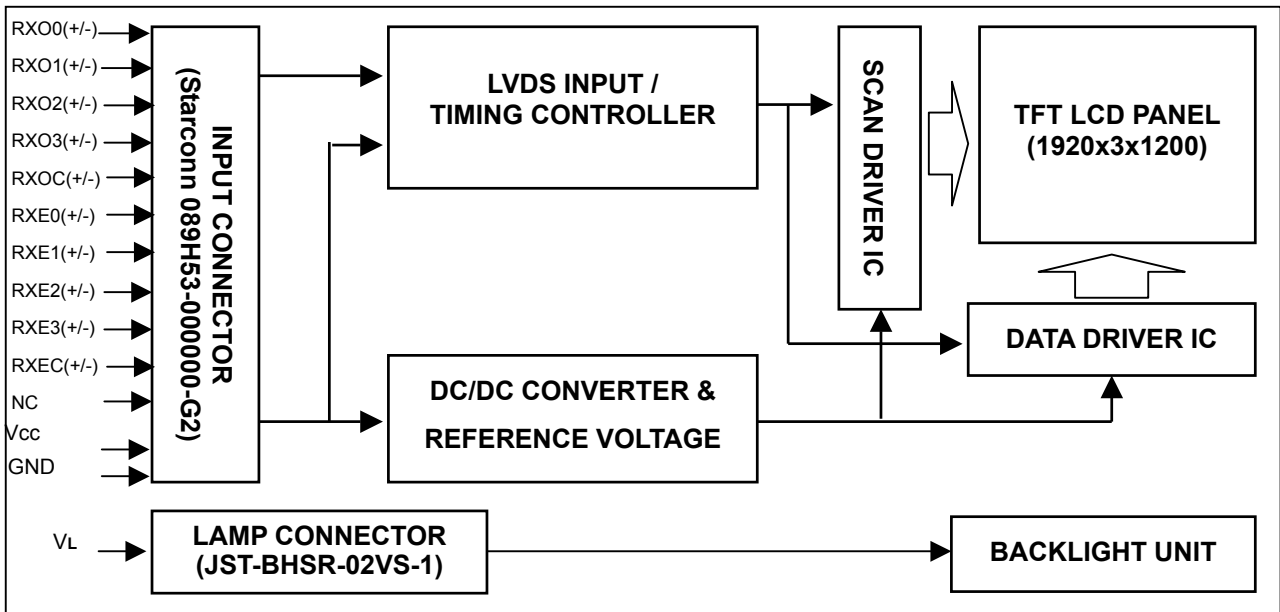

4.2 BACKLIGHT UNIT



5. INPUT TERMINAL PIN ASSIGNMENT

5.1 TFT LCD MODULE

| Pin | Name | Description |
|-----|-------|--|
| 1 | RXO0- | Negative LVDS differential data input. Channel O0 (odd) |
| 2 | RXO0+ | Positive LVDS differential data input. Channel O0 (odd) |
| 3 | RXO1- | Negative LVDS differential data input. Channel O1 (odd) |
| 4 | RXO1+ | Positive LVDS differential data input. Channel O1 (odd) |
| 5 | RXO2- | Negative LVDS differential data input. Channel O2 (odd) |
| 6 | RXO2+ | Positive LVDS differential data input. Channel O2 (odd) |
| 7 | GND | Ground |
| 8 | RXOC- | Negative LVDS differential clock input. (odd) |
| 9 | RXOC+ | Positive LVDS differential clock input. (odd) |
| 10 | RXO3- | Negative LVDS differential data input. Channel O3(odd) |
| 11 | RXO3+ | Positive LVDS differential data input. Channel O3 (odd) |
| 12 | RXE0- | Negative LVDS differential data input. Channel E0 (even) |
| 13 | RXE0+ | Positive LVDS differential data input. Channel E0 (even) |
| 14 | GND | Ground |
| 15 | RXE1- | Negative LVDS differential data input. Channel E1 (even) |
| 16 | RXE1+ | Positive LVDS differential data input. Channel E1 (even) |
| 17 | GND | Ground |
| 18 | RXE2- | Negative LVDS differential data input. Channel E2 (even) |
| 19 | RXE2+ | Positive LVDS differential data input. Channel E2 (even) |
| 20 | RXEC- | Negative LVDS differential clock input. (even) |
| 21 | RXEC+ | Positive LVDS differential clock input. (even) |
| 22 | RXE3- | Negative LVDS differential data input. Channel E3 (even) |
| 23 | RXE3+ | Positive LVDS differential data input. Channel E3 (even) |
| 24 | GND | Ground |
| 25 | NC | Not connection. |
| 26 | NC | Not connection. |
| 27 | VCC | +5.0V power supply |
| 28 | VCC | +5.0V power supply |
| 29 | VCC | +5.0V power supply |
| 30 | VCC | +5.0V power supply |

Note (1) Connector Part No.: JAE-FI-X30SSL-HF or equivalent.

Note (2) The first pixel is odd.

Note (3) Input signal of even and odd clock should be the same timing.

| SELLVDS = Low or Open | | | | | | | | |
|-----------------------|-------------|-----|-----|-----|-----|-----|-----|-----|
| LVDS Channel E0 | LVDS output | D7 | D6 | D4 | D3 | D2 | D1 | D0 |
| | Data order | EG0 | ER5 | ER4 | ER3 | ER2 | ER1 | ER0 |
| LVDS Channel E1 | LVDS output | D18 | D15 | D14 | D13 | D12 | D9 | D8 |
| | Data order | EB1 | EB0 | EG5 | EG4 | EG3 | EG2 | EG1 |
| LVDS Channel E2 | LVDS output | D26 | D25 | D24 | D22 | D21 | D20 | D19 |
| | Data order | DE | NA | NA | EB5 | EB4 | EB3 | EB2 |
| LVDS Channel E3 | LVDS output | D23 | D17 | D16 | D11 | D10 | D5 | D27 |
| | Data order | NA | EB7 | EB6 | EG7 | EG6 | ER7 | ER6 |
| LVDS Channel O0 | LVDS output | D7 | D6 | D4 | D3 | D2 | D1 | D0 |
| | Data order | OG0 | OR5 | OR4 | OR3 | OR2 | OR1 | OR0 |
| LVDS Channel O1 | LVDS output | D18 | D15 | D14 | D13 | D12 | D9 | D8 |
| | Data order | OB1 | OB0 | OG5 | OG4 | OG3 | OG2 | OG1 |
| LVDS Channel O2 | LVDS output | D26 | D25 | D24 | D22 | D21 | D20 | D19 |
| | Data order | DE | NA | NA | OB5 | OB4 | OB3 | OB2 |
| LVDS Channel O3 | LVDS output | D23 | D17 | D16 | D11 | D10 | D5 | D27 |
| | Data order | NA | OB7 | OB6 | OG7 | OG6 | OR7 | OR6 |

5.2 BACKLIGHT UNIT:

| Pin | Symbol | Description | Remark |
|------|--------|--------------|--------|
| 1-1 | HV | High Voltage | Pink |
| 1-2 | HV | High Voltage | White |
| 2-3 | HV | High Voltage | Pink |
| 2-4 | HV | High Voltage | White |
| 3-5 | HV | High Voltage | Pink |
| 3-6 | HV | High Voltage | White |
| 4-7 | HV | High Voltage | Pink |
| 4-8 | HV | High Voltage | White |
| 5-9 | HV | High Voltage | Pink |
| 5-10 | HV | High Voltage | White |
| 6-11 | HV | High Voltage | Pink |
| 6-12 | HV | High Voltage | White |

Note (1) Connector Part No.: BHR-04VS-1 (JST) or equivalent

5.3 COLOR DATA INPUT ASSIGNMENT

The brightness of each primary color (red, green and blue) is based on the 8-bit gray scale data input for the color. The higher the binary input, the brighter the color. The table below provides the assignment of color versus data input.

| Color | | Data Signal | | | | | | | | | | | | | | | | | | | | | | |
|---------------------|-----------------|-------------|----|----|----|----|----|----|----|-------|----|----|----|----|----|----|----|------|----|----|----|----|----|----|
| | | Red | | | | | | | | Green | | | | | | | | Blue | | | | | | |
| | | R7 | R6 | R5 | R4 | R3 | R2 | R1 | R0 | R7 | R6 | G5 | G4 | G3 | G2 | G1 | G0 | R7 | R6 | B5 | B4 | B3 | B2 | B1 |
| Basic Colors | Black | 0 | 0 | 0 | 0 | 0 | 0 | 0 | 0 | 0 | 0 | 0 | 0 | 0 | 0 | 0 | 0 | 0 | 0 | 0 | 0 | 0 | 0 | 0 |
| | Red | 1 | 1 | 1 | 1 | 1 | 1 | 1 | 1 | 0 | 0 | 0 | 0 | 0 | 0 | 0 | 0 | 0 | 0 | 0 | 0 | 0 | 0 | 0 |
| | Green | 0 | 0 | 0 | 0 | 0 | 0 | 0 | 0 | 1 | 1 | 1 | 1 | 1 | 1 | 1 | 1 | 0 | 0 | 0 | 0 | 0 | 0 | 0 |
| | Blue | 0 | 0 | 0 | 0 | 0 | 0 | 0 | 0 | 0 | 0 | 0 | 0 | 0 | 0 | 0 | 0 | 1 | 1 | 1 | 1 | 1 | 1 | 1 |
| | Cyan | 0 | 0 | 0 | 0 | 0 | 0 | 0 | 0 | 1 | 1 | 1 | 1 | 1 | 1 | 1 | 1 | 1 | 1 | 1 | 1 | 1 | 1 | 1 |
| | Magenta | 1 | 1 | 1 | 1 | 1 | 1 | 1 | 1 | 0 | 0 | 0 | 0 | 0 | 0 | 0 | 0 | 1 | 1 | 1 | 1 | 1 | 1 | 1 |
| | Yellow | 1 | 1 | 1 | 1 | 1 | 1 | 1 | 1 | 1 | 1 | 1 | 1 | 1 | 1 | 1 | 1 | 0 | 0 | 0 | 0 | 0 | 0 | 0 |
| | White | 1 | 1 | 1 | 1 | 1 | 1 | 1 | 1 | 1 | 1 | 1 | 1 | 1 | 1 | 1 | 1 | 1 | 1 | 1 | 1 | 1 | 1 | 1 |
| Gray Scale Of Red | Red(0) / Dark | 0 | 0 | 0 | 0 | 0 | 0 | 0 | 0 | 0 | 0 | 0 | 0 | 0 | 0 | 0 | 0 | 0 | 0 | 0 | 0 | 0 | 0 | |
| | Red(1) | 0 | 0 | 0 | 0 | 0 | 0 | 0 | 1 | 0 | 0 | 0 | 0 | 0 | 0 | 0 | 0 | 0 | 0 | 0 | 0 | 0 | 0 | |
| | Red(2) | 0 | 0 | 0 | 0 | 0 | 0 | 1 | 0 | 0 | 0 | 0 | 0 | 0 | 0 | 0 | 0 | 0 | 0 | 0 | 0 | 0 | 0 | |
| | ⋮ | ⋮ | ⋮ | ⋮ | ⋮ | ⋮ | ⋮ | ⋮ | ⋮ | ⋮ | ⋮ | ⋮ | ⋮ | ⋮ | ⋮ | ⋮ | ⋮ | ⋮ | ⋮ | ⋮ | ⋮ | ⋮ | | |
| | ⋮ | ⋮ | ⋮ | ⋮ | ⋮ | ⋮ | ⋮ | ⋮ | ⋮ | ⋮ | ⋮ | ⋮ | ⋮ | ⋮ | ⋮ | ⋮ | ⋮ | ⋮ | ⋮ | ⋮ | ⋮ | ⋮ | | |
| | ⋮ | ⋮ | ⋮ | ⋮ | ⋮ | ⋮ | ⋮ | ⋮ | ⋮ | ⋮ | ⋮ | ⋮ | ⋮ | ⋮ | ⋮ | ⋮ | ⋮ | ⋮ | ⋮ | ⋮ | ⋮ | ⋮ | | |
| | Red(253) | 1 | 1 | 1 | 1 | 1 | 1 | 0 | 1 | 0 | 0 | 0 | 0 | 0 | 0 | 0 | 0 | 0 | 0 | 0 | 0 | 0 | 0 | |
| | Red(254) | 1 | 1 | 1 | 1 | 1 | 1 | 1 | 0 | 0 | 0 | 0 | 0 | 0 | 0 | 0 | 0 | 0 | 0 | 0 | 0 | 0 | 0 | |
| Red(255) | 1 | 1 | 1 | 1 | 1 | 1 | 1 | 0 | 0 | 0 | 0 | 0 | 0 | 0 | 0 | 0 | 0 | 0 | 0 | 0 | 0 | 0 | | |
| Gray Scale Of Green | Green(0) / Dark | 0 | 0 | 0 | 0 | 0 | 0 | 0 | 0 | 0 | 0 | 0 | 0 | 0 | 0 | 0 | 0 | 0 | 0 | 0 | 0 | 0 | 0 | |
| | Green(1) | 0 | 0 | 0 | 0 | 0 | 0 | 0 | 0 | 0 | 0 | 0 | 0 | 0 | 0 | 1 | 0 | 0 | 0 | 0 | 0 | 0 | 0 | |
| | Green(2) | 0 | 0 | 0 | 0 | 0 | 0 | 0 | 0 | 0 | 0 | 0 | 0 | 0 | 1 | 0 | 0 | 0 | 0 | 0 | 0 | 0 | 0 | |
| | ⋮ | ⋮ | ⋮ | ⋮ | ⋮ | ⋮ | ⋮ | ⋮ | ⋮ | ⋮ | ⋮ | ⋮ | ⋮ | ⋮ | ⋮ | ⋮ | ⋮ | ⋮ | ⋮ | ⋮ | ⋮ | ⋮ | | |
| | ⋮ | ⋮ | ⋮ | ⋮ | ⋮ | ⋮ | ⋮ | ⋮ | ⋮ | ⋮ | ⋮ | ⋮ | ⋮ | ⋮ | ⋮ | ⋮ | ⋮ | ⋮ | ⋮ | ⋮ | ⋮ | ⋮ | | |
| | ⋮ | ⋮ | ⋮ | ⋮ | ⋮ | ⋮ | ⋮ | ⋮ | ⋮ | ⋮ | ⋮ | ⋮ | ⋮ | ⋮ | ⋮ | ⋮ | ⋮ | ⋮ | ⋮ | ⋮ | ⋮ | ⋮ | | |
| | Green(253) | 0 | 0 | 0 | 0 | 0 | 0 | 0 | 0 | 1 | 1 | 1 | 1 | 1 | 1 | 0 | 1 | 0 | 0 | 0 | 0 | 0 | 0 | |
| | Green(254) | 0 | 0 | 0 | 0 | 0 | 0 | 0 | 0 | 1 | 1 | 1 | 1 | 1 | 1 | 0 | 0 | 0 | 0 | 0 | 0 | 0 | 0 | |
| Green(255) | 0 | 0 | 0 | 0 | 0 | 0 | 0 | 0 | 1 | 1 | 1 | 1 | 1 | 1 | 1 | 0 | 0 | 0 | 0 | 0 | 0 | 0 | | |
| Gray Scale Of Blue | Blue(0) / Dark | 0 | 0 | 0 | 0 | 0 | 0 | 0 | 0 | 0 | 0 | 0 | 0 | 0 | 0 | 0 | 0 | 0 | 0 | 0 | 0 | 0 | 0 | |
| | Blue(1) | 0 | 0 | 0 | 0 | 0 | 0 | 0 | 0 | 0 | 0 | 0 | 0 | 0 | 0 | 0 | 0 | 0 | 0 | 0 | 0 | 0 | 1 | |
| | Blue(2) | 0 | 0 | 0 | 0 | 0 | 0 | 0 | 0 | 0 | 0 | 0 | 0 | 0 | 0 | 0 | 0 | 0 | 0 | 0 | 0 | 0 | 1 | |
| | ⋮ | ⋮ | ⋮ | ⋮ | ⋮ | ⋮ | ⋮ | ⋮ | ⋮ | ⋮ | ⋮ | ⋮ | ⋮ | ⋮ | ⋮ | ⋮ | ⋮ | ⋮ | ⋮ | ⋮ | ⋮ | ⋮ | | |
| | ⋮ | ⋮ | ⋮ | ⋮ | ⋮ | ⋮ | ⋮ | ⋮ | ⋮ | ⋮ | ⋮ | ⋮ | ⋮ | ⋮ | ⋮ | ⋮ | ⋮ | ⋮ | ⋮ | ⋮ | ⋮ | ⋮ | | |
| | ⋮ | ⋮ | ⋮ | ⋮ | ⋮ | ⋮ | ⋮ | ⋮ | ⋮ | ⋮ | ⋮ | ⋮ | ⋮ | ⋮ | ⋮ | ⋮ | ⋮ | ⋮ | ⋮ | ⋮ | ⋮ | ⋮ | | |
| | Blue(253) | 0 | 0 | 0 | 0 | 0 | 0 | 0 | 0 | 0 | 0 | 0 | 0 | 0 | 0 | 0 | 1 | 1 | 1 | 1 | 1 | 1 | 0 | |
| | Blue(254) | 0 | 0 | 0 | 0 | 0 | 0 | 0 | 0 | 0 | 0 | 0 | 0 | 0 | 0 | 0 | 1 | 1 | 1 | 1 | 1 | 1 | 0 | |
| Blue(255) | 0 | 0 | 0 | 0 | 0 | 0 | 0 | 0 | 0 | 0 | 0 | 0 | 0 | 0 | 0 | 1 | 1 | 1 | 1 | 1 | 1 | 1 | | |

Note (1) 0: Low Level Voltage, 1: High Level Voltage

6. INTERFACE TIMING

6.1 INPUT SIGNAL TIMING SPECIFICATIONS

The input signal timing specifications are shown as the following table and timing diagram.

| Signal | Item | Symbol | Min. | Typ. | Max. | Unit | Note |
|--------------------------------|------------|--------|--------|------|--------|------|------------|
| LVDS Clock | Frequency | Fc | - | 77 | (83.0) | MHz | - |
| | Period | Tc | - | 13.0 | - | ns | - |
| | High Time | Tch | - | 4/7 | - | Tc | - |
| | Low Time | Tcl | - | 3/7 | - | Tc | - |
| LVDS Data | Setup Time | Tlvs | 600 | - | - | ps | - |
| | Hold Time | Tlvh | 600 | - | - | ps | - |
| Vertical Active Display Term | Frame Rate | Fr | - | 60 | (63) | Hz | Tv=Tvd+Tvb |
| | Total | Tv | (1209) | 1235 | (1245) | Th | - |
| | Display | Tvd | 1200 | 1200 | 1200 | Th | - |
| | Blank | Tvb | (9) | 35 | Tv-Tvd | Th | - |
| Horizontal Active Display Term | Total | Th | (1030) | 1040 | (1075) | Tc | Th=Thd+Thb |
| | Display | Thd | 960 | 960 | 960 | Tc | - |
| | Blank | Thb | (70) | 80 | Th-Thd | Tc | - |

Note: Because this module is operated by DE only mode, Hsync and Vsync input signals should be set to low logic level or ground. Otherwise, this module would operate abnormally.

INPUT SIGNAL TIMING DIAGRAM

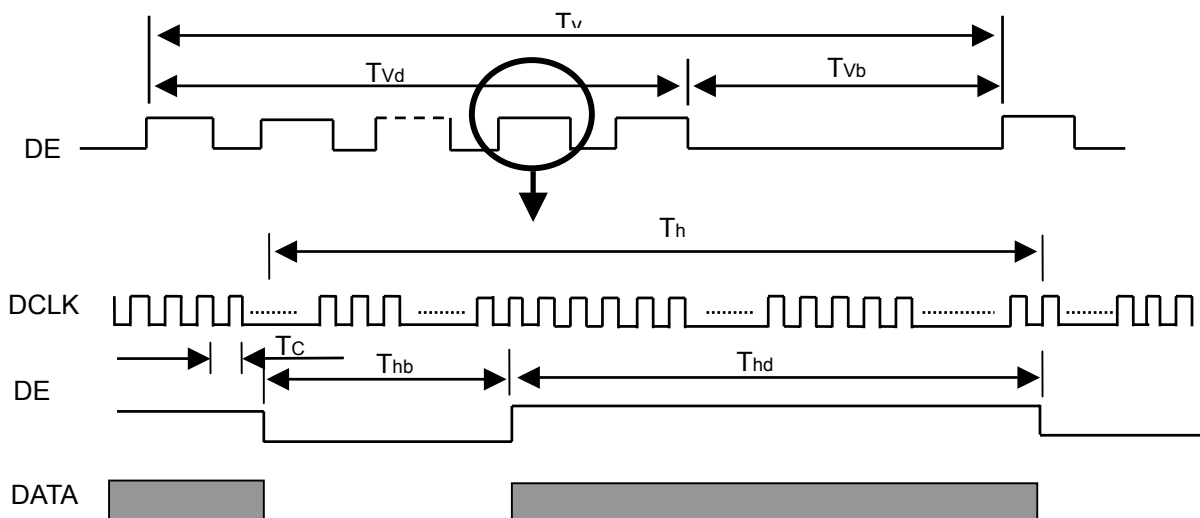

6.2 POWER ON/OFF SEQUENCE

To prevent a latch-up or DC operation of LCD module, the power on/off sequence should be as the diagram below.

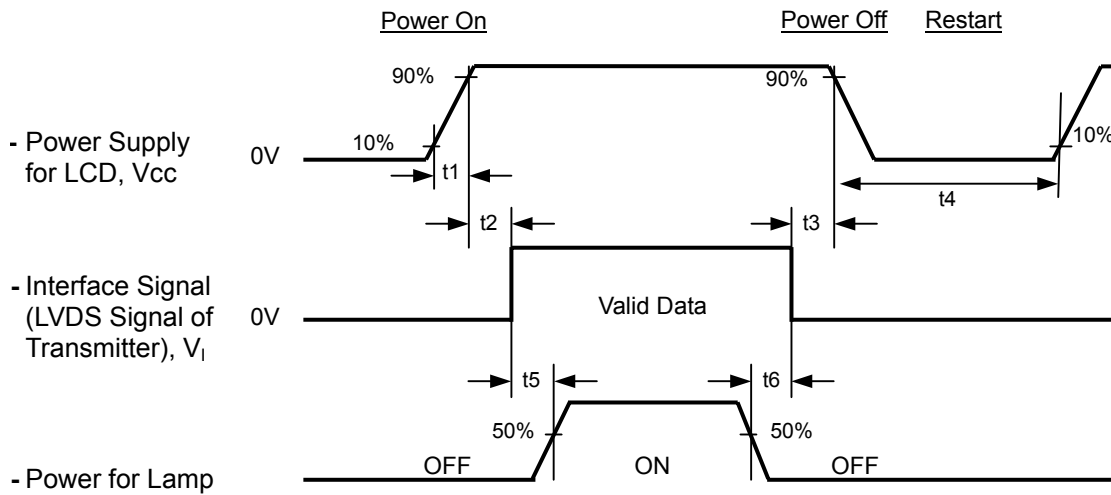

Timing Specifications:

$$0.5 < t_1 \leq 10 \text{ msec}$$

$$0 < t_2 \leq 50 \text{ msec}$$

$$0 < t_3 \leq 50 \text{ msec}$$

$$t_4 \geq 500 \text{ msec}$$

$$t_5 \geq 500 \text{ msec}$$

$$t_6 \geq 90 \text{ msec}$$

7. OPTICAL CHARACTERISTICS

7.1 TEST CONDITIONS

| Item | Symbol | Value | Unit |
|------------------------------|---|-------|------|
| Ambient Temperature | Ta | 25±2 | °C |
| Ambient Humidity | Ha | 50±10 | %RH |
| Supply Voltage | V _{CC} | 5.0 | V |
| Input Signal | According to typical value in "3. ELECTRICAL CHARACTERISTICS" | | |
| Lamp Current | I _L | (5.3) | mA |
| Inverter Operating Frequency | F _L | TBD | KHz |
| Inverter | | TBD | |

7.2 OPTICAL SPECIFICATIONS

The relative measurement methods of optical characteristics are shown in 7.2. The following items should be measured under the test conditions described in 7.1 and stable environment shown in Note (6).

| Item | Symbol | Condition | Min. | Typ. | Max. | Unit | Note |
|--|----------------------|--|---------|---------|--------|-------------------|----------|
| Color Chromaticity (CIE 1931) | Red | Rx | | TBD | | - | (1), (5) |
| | | Ry | | TBD | | | |
| | Green | Gx | | TBD | | | |
| | | Gy | | TBD | | | |
| | Blue | Bx | | TBD | | | |
| | | By | | TBD | | | |
| | White | Wx | | (0.313) | | | |
| Wy | | | (0.329) | | | | |
| Color Chromaticity (CIE 1976) | Red | Ru' | 0.411 | - | - | - | TCO '03 |
| | | Rv' | 0.503 | - | - | - | |
| | Green | Gu' | - | - | 0.140 | - | |
| | | Gv' | 0.548 | - | - | - | |
| | Blue | Bu' | 0.150 | - | - | - | |
| | | Bv' | - | - | 0.224 | - | |
| | White | Wu' | | 0.198 | | - | |
| | | Wv' | | 0.468 | | - | |
| Center Luminance of White (Center of Screen) | L _C | | - | (300) | - | cd/m ² | (4), (5) |
| Contrast Ratio | CR | | - | (1000) | - | - | (2), (5) |
| Response Time | T _R | θ _x =0°, θ _y =0° | - | (13) | - | ms | (3), (7) |
| | T _F | | - | (7) | - | | |
| | T _{GTG AVE} | | - | (8) | - | | |
| White Variation | δW | θ _x =0°, θ _y =0° CA-210 | - | (1.25) | (1.40) | - | (5), (6) |
| Viewing Angle | Horizontal | θ _{x+} | - | (89) | - | Deg. | (1), (5) |
| | | θ _{x-} | - | (89) | - | | |
| | Vertical | θ _{y+} | - | (89) | - | | |
| | | θ _{y-} | - | (89) | - | | |

Note (1) Definition of Viewing Angle (θ_x, θ_y):

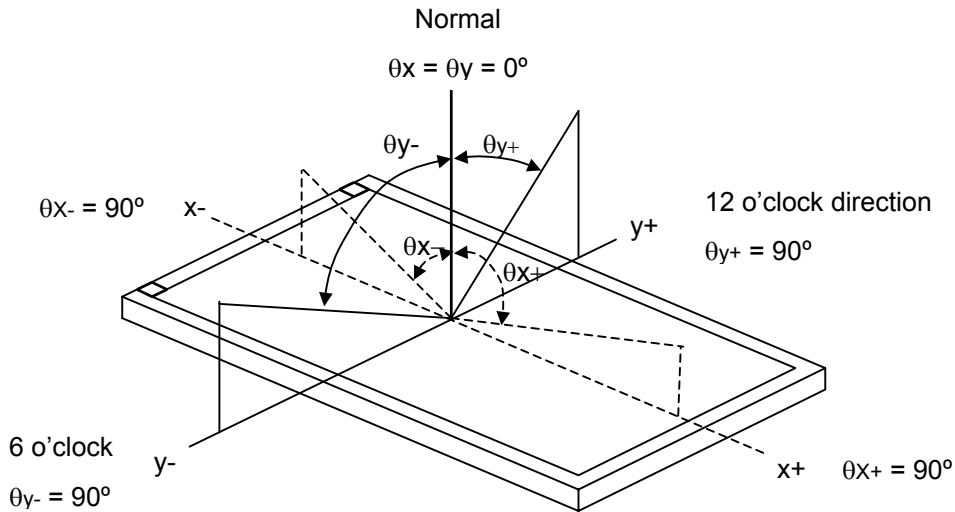

Note (2) Definition of Contrast Ratio (CR):

The contrast ratio can be calculated by the following expression.

$$\text{Contrast Ratio (CR)} = L_{255} / L_0$$

L255: Luminance of gray level 255

L 0: Luminance of gray level 0

$$\text{CR} = \text{CR} (7)$$

CR (X) is corresponding to the Contrast Ratio of the point X at Figure in Note (6).

Note (3) Definition of Response Time (T_R, T_F):

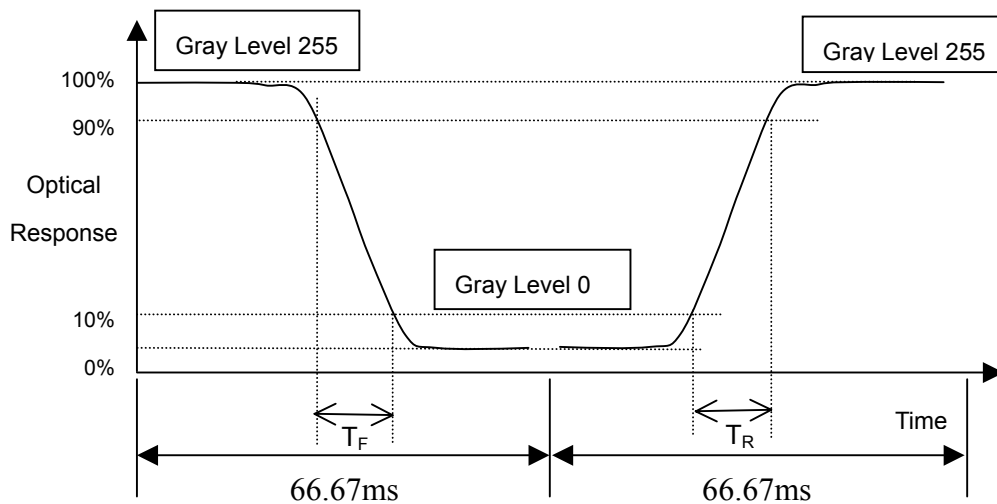

Note (4) Definition of Luminance of White (L_C):

Measure the luminance of gray level 255 at center point

$$L_C = L (7)$$

L (x) is corresponding to the luminance of the point X at Figure in Note (6).

Note (5) Measurement Setup:

The LCD module should be stabilized at given temperature for **60 minutes** to avoid abrupt temperature change during measuring. In order to stabilize the luminance, the measurement should be executed after lighting Backlight for **60 minutes** in a windless room.

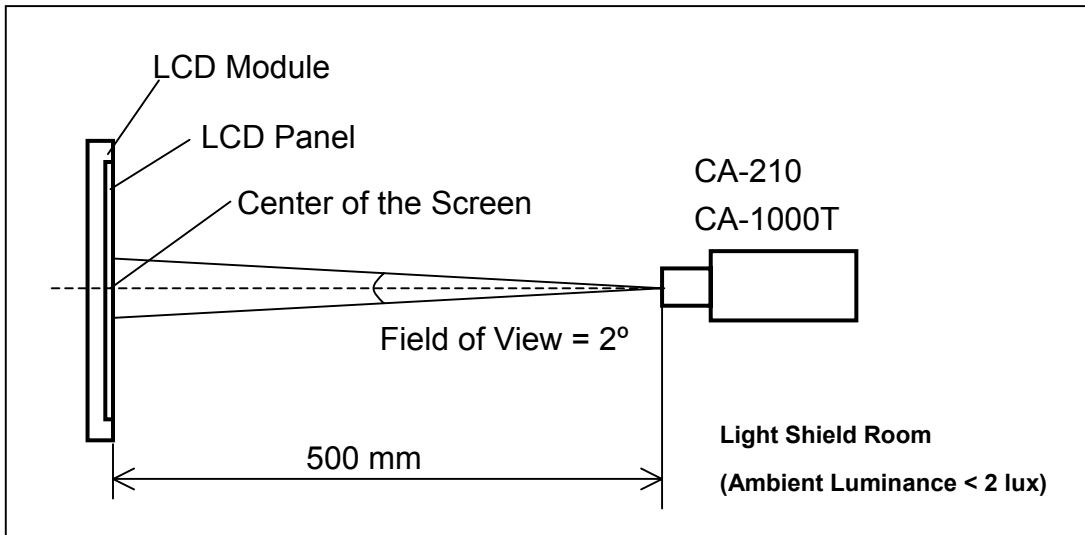

Note (6) Definition of White Variation (δW):

Measure the luminance of gray level 255 at 13 points

$$\delta W = \text{Maximum [L (1), L (2) L (12), L (13)]} / \text{Minimum [L (1), L (2) L (12), L (13)]}$$

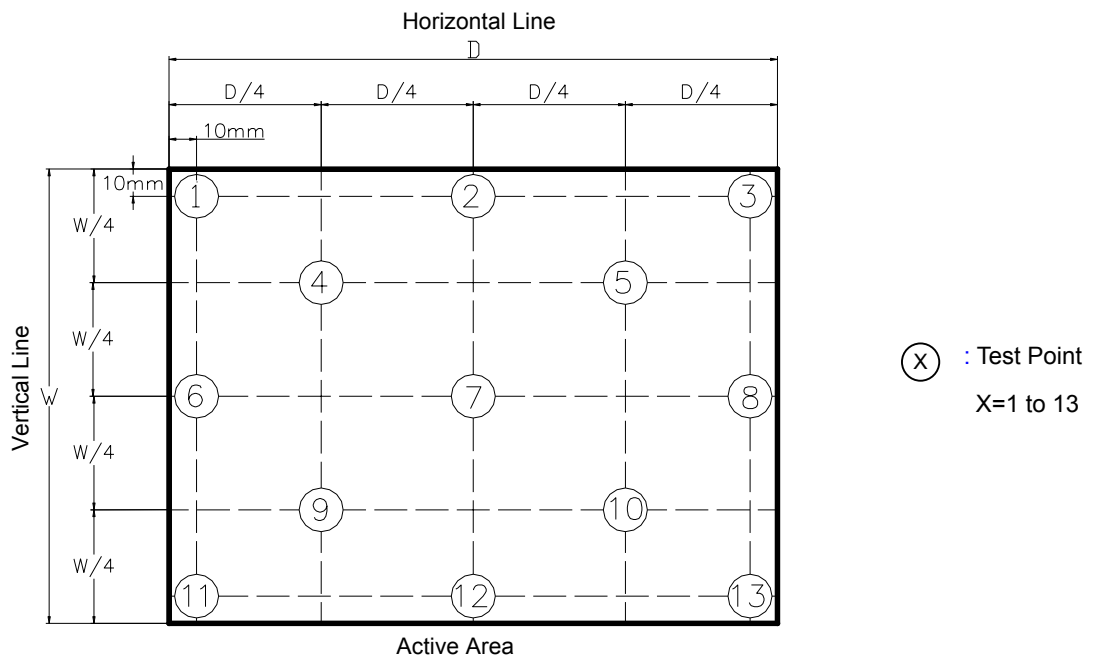

Note (7) Definition of Response Time (T_{GTG_AVE}):

T_{GTG_AVE} is defined as the total average response time for "Gray To Gray".

The Gray to Gray response time is defined as the following chart.

| Gray to Gray | | Target Gray | | | | | | | | |
|--------------|------|-------------|-----|-----|-----|------|------|------|------|------|
| | | G0 | G32 | G64 | G96 | G128 | G160 | G192 | G224 | G255 |
| Initial Gray | G0 | | | | | | | | | |
| | G32 | | | | | | | | | |
| | G64 | | | | | | | | | |
| | G96 | | | | | | | | | |
| | G128 | | | | | | | | | |
| | G160 | | | | | | | | | |
| | G192 | | | | | | | | | |
| | G224 | | | | | | | | | |
| | G255 | | | | | | | | | |

8. PACKAGING

8.1 PACKING SPECIFICATIONS

- (1) 5 LCD modules / 1 Box
- (2) Box dimensions: 537(L) X 316(W) X 462(H) mm
- (3) Weight: approximately 15Kg (5 modules per box)

8.2 PACKING METHOD

- (1) Carton Packing should have no failure in the following reliability test items.

| Test Item | Test Conditions | Note |
|---------------|--|---------------|
| Vibration | ISTA STANDARD Random, Frequency Range: 1 – 200 Hz Top & Bottom: 30 minutes (+Z), 10 min (-Z), Right & Left: 10 minutes (X) Back & Forth 10 minutes (Y) | Non Operation |
| Dropping Test | 1 Angle, 3 Edge, 6 Face, 60cm | Non Operation |

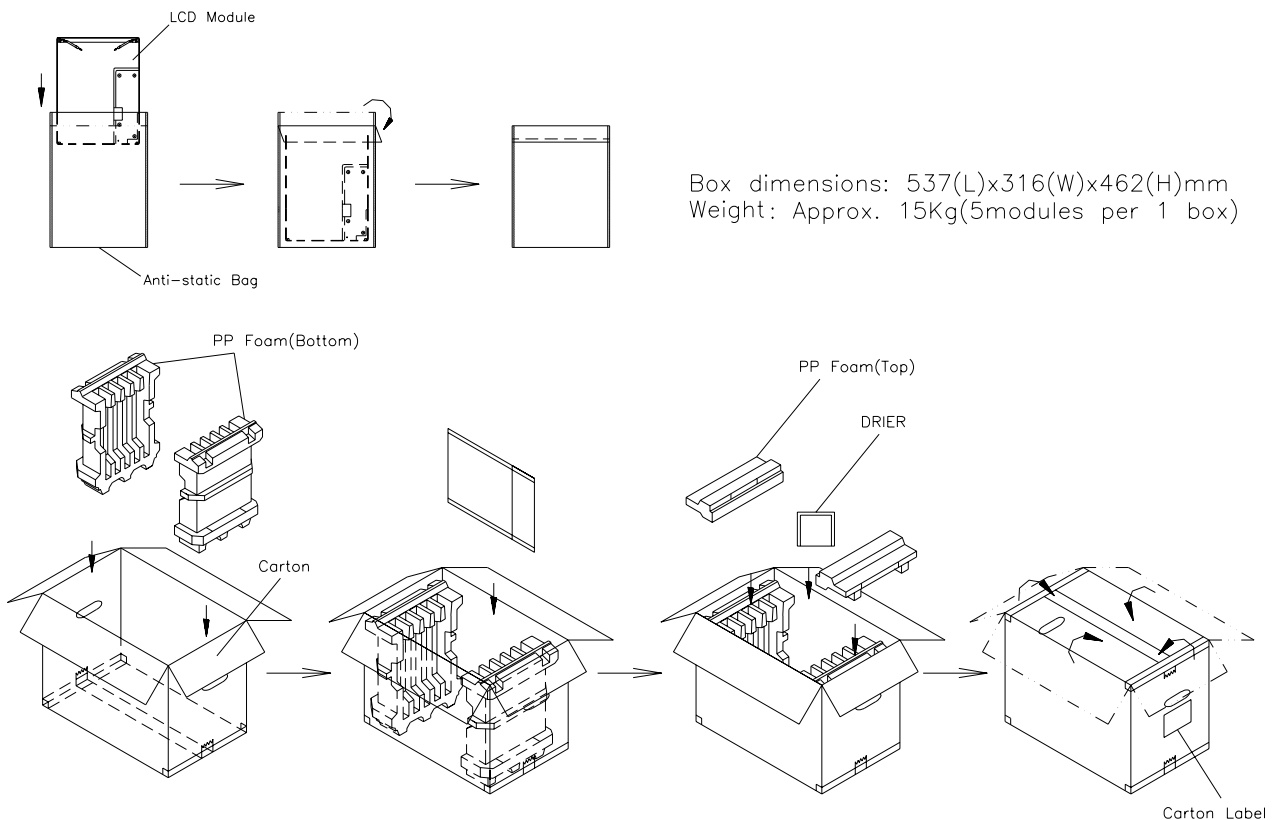

Figure. 8-1 Packing method

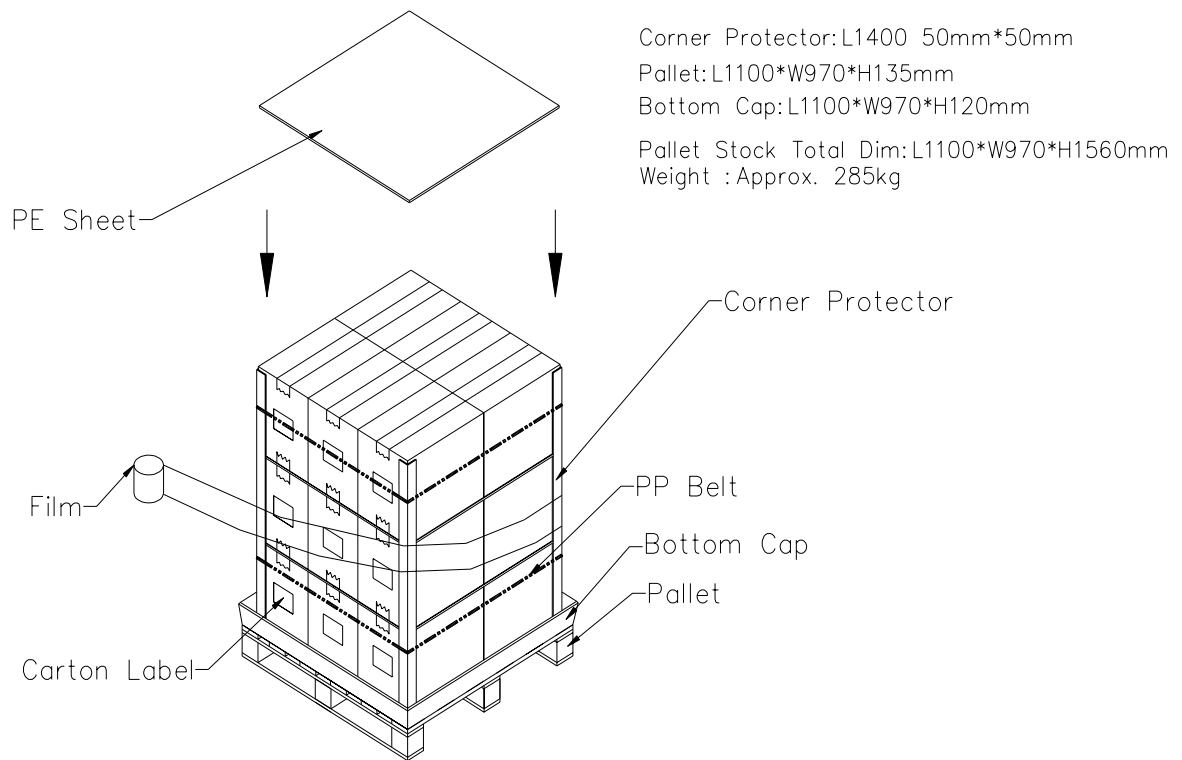

Figure. 8-2 Packing method

9. DEFINITION OF LABELS

9.1 CMO MODULE LABEL

The barcode nameplate is pasted on each module as illustration, and its definitions are as following explanation.



- (a) Model Name: M240J1-L01
- (b) Revision: Rev. XX, for example: A0, A1... B1, B2... or C1, C2...etc.
- (c) CMO barcode definition:

Serial ID: XX-XX-X-XX-YMD-L-NNNN

| Code | Meaning | Description |
|------|------------------|---|
| XX | CMO internal use | - |
| XX | Revision | Cover all the change |
| X | CMO internal use | - |
| YMD | Year, month, day | Year: 2001=1, 2002=2, 2003=3, 2004=4... Month: 1~12=1, 2, 3, ~, 9, A, B, C Day: 1~31=1, 2, 3, ~, 9, A, B, C, ~, W, X, Y, exclude I, O, and U. |
| L | Product line # | Line 1=1, Line 2=2, Line 3=3, ... |
| NNNN | Serial number | Manufacturing sequence of product |

- (d) Customer's barcode definition:

Serial ID: CM-19E3A-X-X-X-XX-L-XX-L-YMD-NNNN

| Code | Meaning | Description |
|-------|-----------------------|---|
| CM | Supplier code | CMO=CM |
| 24J11 | Model number | M240J1-L01 = 24J11 |
| X | Revision code | Non ZBD: 0~9, ZBD: A~Z |
| X | Source driver IC code | Century=1, CLL=2, Demos=3, Epson=4, Fujitsu=5, Himax=6, Hitachi=7, Hynix=8, LDI=9, Matsushita=A, NEC=B, Novatec=C, OKI=D, Philips=E, Renesas=F, Samsung=G, Sanyo=H, Sharp=I, TI=J, Topro=K, Toshiba=L, Windbond=M |
| X | Gate driver IC code | |
| XX | Cell location | Tainan, Taiwan=TN |
| L | Cell line # | 1~12=0~C |
| XX | Module location | Tainan, Taiwan=TN |
| L | Module line # | 1~12=0~C |
| YMD | Year, month, day | Year: 2001=1, 2002=2, 2003=3, 2004=4... Month: 1~12=1, 2, 3, ~, 9, A, B, C Day: 1~31=1, 2, 3, ~, 9, A, B, C, ~, T, U, V |
| NNNN | Serial number | By LCD supplier |

10. PRECAUTIONS

10.1 ASSEMBLY AND HANDLING PRECAUTIONS

- (1) Do not apply rough force such as bending or twisting to the module during assembly.
- (2) To assemble or install module into user's system can be only in clean working areas. The dust and oil may cause electrical short or worsen the polarizer.
- (3) It's not permitted to have pressure or impulse on the module because the LCD panel and Backlight will be damaged.
- (4) Always follow the correct power sequence when LCD module is connecting and operating. This can prevent damage to the CMOS LSI chips during latch-up.
- (5) Do not pull the I/F connector in or out while the module is operating.
- (6) Do not disassemble the module.
- (7) Use a soft dry cloth without chemicals for cleaning, because the surface of polarizer is very soft and easily scratched.
- (8) It is dangerous that moisture come into or contacted the LCD module, because moisture may damage LCD module when it is operating.
- (9) High temperature or humidity may reduce the performance of module. Please store LCD module within the specified storage conditions.
- (10) When ambient temperature is lower than 10°C may reduce the display quality. For example, the response time will become slowly, and the starting voltage of CCFL will be higher than room temperature.

10.2 SAFETY PRECAUTIONS

- (1) The startup voltage of Backlight is approximately 1000 Volts. It may cause electrical shock while assembling with inverter. Do not disassemble the module or insert anything into the Backlight unit.
- (2) If the liquid crystal material leaks from the panel, it should be kept away from the eyes or mouth. In case of contact with hands, skin or clothes, it has to be washed away thoroughly with soap.
- (3) After the module's end of life, it is not harmful in case of normal operation and storage.

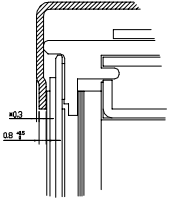

SECTION YY-YY
SCALE 5:1

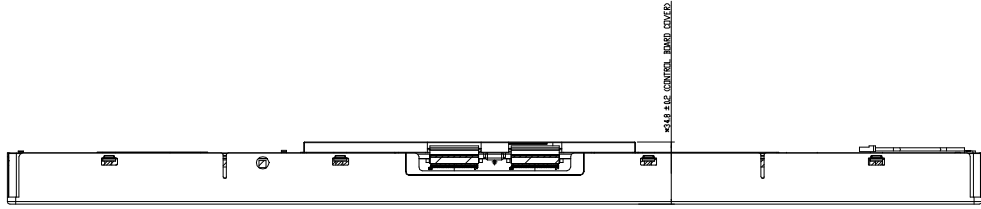

454.4 ± 0.25 (OUT. SIZE)

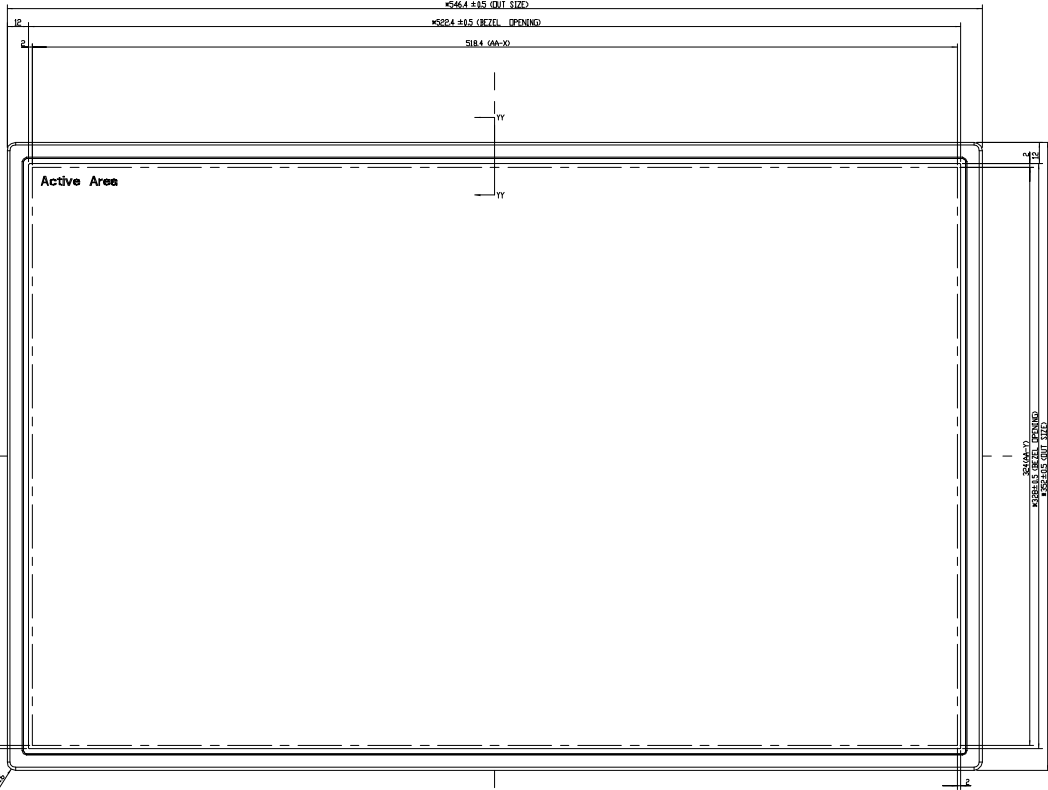

454.4

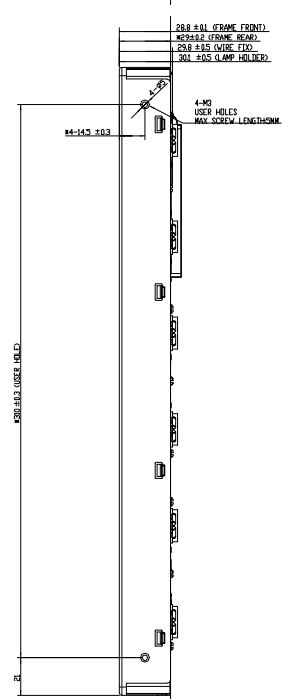

288 ± 0.1 (FRAME FRONT)
452.4 ± 0.2 (FRAME BACK)
454.4 ± 0.25 (CASE FID.)
518.4 ± 0.25 (APP. HOLDER)
4-#0 USER HOLES
MAX. SCREW LENGTH 3.0MM

NOTES:
1. THIS DRAWING IS THE DESIGN CRITERIA DOCUMENT.
2. 0.1" MIN. IS THE PROCESS CRITICAL DIMENSION.
3. MAX. SCREW LENGTH IS 3.0MM.
4. MAX. SCREW TORQUE IS 0.15 NCM (5 lbf-in).
5. WEIGHT: 30.0G (MAX)

| TITLE | | JSTY MEKAL_MENJI | | REV. NO. | | REVISED | |
|----------|----------------------------|------------------|------------|----------|-------------------------------|---|------------|
| Approved | JSTY CHING | Drawing No. | MENJ001 | Checked | JSTY CHING | Part No. | MENJ001 |
| Designed | JSTY CHING | Drawn | JSTY CHING | Drawn | JSTY CHING | Scale | 1:1 |
| General | Tolerance Unless Specified | Material | FR-4 | Quantity | 1 | Sheet | 1 of 2 |
| 0-8 | ±0.1 | 300-600 | ±0.3 | Designer | JSTY CHING | Date | 13-11-2009 |
| 8-30 | ±0.15 | 1000- | ±0.5 | Drawn | JSTY CHING | Scale | 1:1 |
| 30-500 | ±0.2 | ANGLE | ±1.0° | Company | CHI MEI OPTOELECTRONICS CORP. | ALL RIGHTS RESERVED. OFFICE FURNISHING. | |

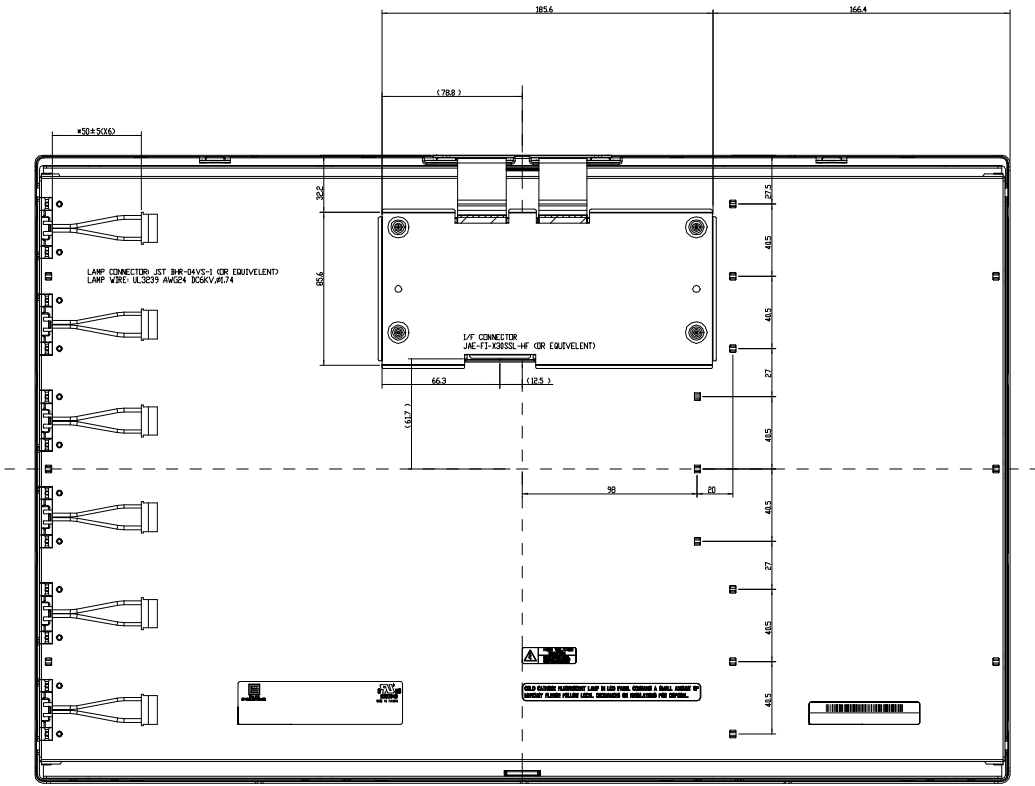

| Mark | Description | Date | Changed_By | Approved_By | ECN No. | Remark |
|------|-------------|------|------------|-------------|---------|--------|
| 1 | | | | | | |
| 2 | | | | | | |
| 3 | | | | | | |

| | | | |
|--|----------------------------|--------------------------------------|---------------|
| TITLE: J557, J558, J559, J560, J561, J562, J563, J564, J565, J566, J567, J568, J569, J570, J571, J572, J573, J574, J575, J576, J577, J578, J579, J580, J581, J582, J583, J584, J585, J586, J587, J588, J589, J590, J591, J592, J593, J594, J595, J596, J597, J598, J599, J600, J601, J602, J603, J604, J605, J606, J607, J608, J609, J610, J611, J612, J613, J614, J615, J616, J617, J618, J619, J620, J621, J622, J623, J624, J625, J626, J627, J628, J629, J630, J631, J632, J633, J634, J635, J636, J637, J638, J639, J640, J641, J642, J643, J644, J645, J646, J647, J648, J649, J650, J651, J652, J653, J654, J655, J656, J657, J658, J659, J660, J661, J662, J663, J664, J665, J666, J667, J668, J669, J670, J671, J672, J673, J674, J675, J676, J677, J678, J679, J680, J681, J682, J683, J684, J685, J686, J687, J688, J689, J690, J691, J692, J693, J694, J695, J696, J697, J698, J699, J700, J701, J702, J703, J704, J705, J706, J707, J708, J709, J710, J711, J712, J713, J714, J715, J716, J717, J718, J719, J720, J721, J722, J723, J724, J725, J726, J727, J728, J729, J730, J731, J732, J733, J734, J735, J736, J737, J738, J739, J740, J741, J742, J743, J744, J745, J746, J747, J748, J749, J750, J751, J752, J753, J754, J755, J756, J757, J758, J759, J760, J761, J762, J763, J764, J765, J766, J767, J768, J769, J770, J771, J772, J773, J774, J775, J776, J777, J778, J779, J780, J781, J782, J783, J784, J785, J786, J787, J788, J789, J790, J791, J792, J793, J794, J795, J796, J797, J798, J799, J800, J801, J802, J803, J804, J805, J806, J807, J808, J809, J810, J811, J812, J813, J814, J815, J816, J817, J818, J819, J820, J821, J822, J823, J824, J825, J826, J827, J828, J829, J830, J831, J832, J833, J834, J835, J836, J837, J838, J839, J840, J841, J842, J843, J844, J845, J846, J847, J848, J849, J850, J851, J852, J853, J854, J855, J856, J857, J858, J859, J860, J861, J862, J863, J864, J865, J866, J867, J868, J869, J870, J871, J872, J873, J874, J875, J876, J877, J878, J879, J880, J881, J882, J883, J884, J885, J886, J887, J888, J889, J890, J891, J892, J893, J894, J895, J896, J897, J898, J899, J900, J901, J902, J903, J904, J905, J906, J907, J908, J909, J910, J911, J912, J913, J914, J915, J916, J917, J918, J919, J920, J921, J922, J923, J924, J925, J926, J927, J928, J929, J930, J931, J932, J933, J934, J935, J936, J937, J938, J939, J940, J941, J942, J943, J944, J945, J946, J947, J948, J949, J950, J951, J952, J953, J954, J955, J956, J957, J958, J959, J960, J961, J962, J963, J964, J965, J966, J967, J968, J969, J970, J971, J972, J973, J974, J975, J976, J977, J978, J979, J980, J981, J982, J983, J984, J985, J986, J987, J988, J989, J990, J991, J992, J993, J994, J995, J996, J997, J998, J999, J1000 | | REVISED | |
| APPROVED: JERRY CHING | | DRAWING NO: J557-001 | REVISED: |
| CHECKED: JERRY CHING | | PART NO: J557-001 | REVISED: |
| General | Tolerance Unless Specified | Drawn: TERRY WANG | Material: TYP |
| 0-6 | ±0.1 | 300-600 | ±0.3 |
| 6-30 | ±0.15 | 1000- | ±0.6 |
| 30-300 | ±0.2 | ANGLE | ±1.0 |
| CHI MEI OPTOELECTRONICS CORP. | | ALL RIGHTS RESERVED. OFFICE: FOSHAN. | |