

## MOS INTEGRATED CIRCUIT

### RHYTHM GENERATOR

- LOW POWER DISSIPATION: < 120 mW
- DRIVES 8 SOUND GENERATORS (INSTRUMENTS)
- 15 PROGRAMMABLE RHYTHMS (NOT AVAILABLE IN COMBINATION)
- MASK PROGRAMMABLE RESET COUNTS: 24 or 32
- DOWN BEAT OUTPUT
- EXTERNAL RESET
- OPEN DRAIN OUTPUTS
- STANDARD MUSIC CONTENT AVAILABLE
- TECHNICAL NOTE NO 131 AVAILABLE FOR FULL INFORMATION

The M252 is a monolithic rhythm generator specifically designed for electronic organs and other musical instruments.

Constructed on a single chip using low threshold P-channel silicon gate technology it is supplied in a 16-lead dual in-line plastic package.

### ABSOLUTE MAXIMUM RATINGS\*

|               |                             |            |    |
|---------------|-----------------------------|------------|----|
| $V_{GG}^{**}$ | Source supply voltage       | -20 to 0.3 | V  |
| $V_I^{**}$    | Input voltage               | -20 to 0.3 | V  |
| $I_o$         | Output current (at any pin) | 3          | mA |
| $T_{stg}$     | Storage temperature         | -65 to 150 | °C |
| $T_{op}$      | Operating temperature       | 0 to 70    | °C |

\* Stresses above those listed under "Absolute Maximum Ratings" may cause permanent damage to the device. This is a stress rating only and functional operation of the device at these or any other condition above those indicate in the "Recommended operating conditions" section of this specification is not implied. Exposure to absolute maximum rating conditions for extended periods may affect device reliability.

\*\* This voltage is with respect to  $V_{SS}$  pin voltage.

**ORDERING NUMBERS:** M252 B1 XX for dual in-line plastic package

M252 B1 AA and AD for standard music content

### MECHANICAL DATA

Dimensions in mm

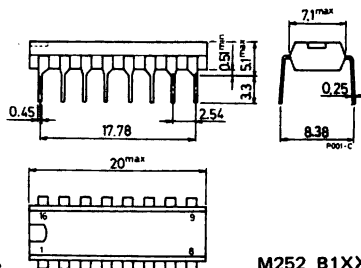

## CONNECTION DIAGRAMS

Standard content configuration  
M252 B1 AA

Standard content configuration  
M252 B1 AD

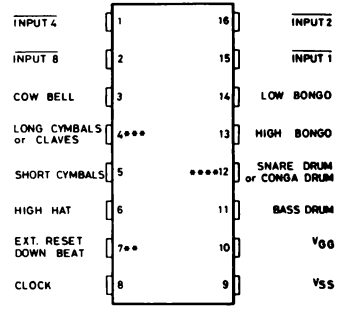
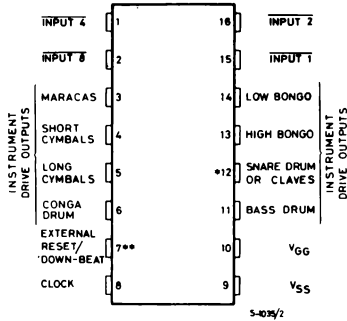
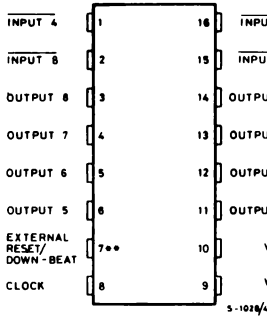

- \* This output must be connected so as to drive the "snare drum" when the rhythms from 1 to 9 (see rhythm selection) are selected, and the "claves" when the rhythms from 10 to 15 (see rhythm selection) are selected.
- \*\* This pin generates a down-beat trigger which can be used to drive an external lamp to indicate the first beat of each rhythm.
- \*\*\* This output must be connected so as to drive the "long cymbals" when the rhythms number 1, 3, 4, 12 and 14 are generated, and the "claves" when the rhythms number 5, 8, 9, 10, 11 and 13 are generated.
- \*\*\*\* This output must be connected so as to drive the "snare drum" when the rhythms number 1, 3, 4, 6, 7, 9, 12, 14 and 15 are generated, and the "conga drum" when the rhythms number 5, 8, 10, 11 and 13 are generated.

## RHYTHM SELECTION

The following binary code must be generated to select each rhythm (positive logic)

| RHYTHM             | CODE    |         |         |         | STANDARD CONTENT-AA | STANDARD CONTENT-AD |
|--------------------|---------|---------|---------|---------|---------------------|---------------------|
|                    | INPUT 8 | INPUT 4 | INPUT 2 | INPUT 1 |                     |                     |
| 1                  | 1       | 1       | 1       | 0       | Waltz 3/4           | Waltz 3/4           |
| 2                  | 1       | 1       | 0       | 1       | Jazz Waltz 3/4      | Tango 2/4           |
| 3                  | 1       | 1       | 0       | 0       | Tango 2/4           | March 2/4           |
| 4                  | 1       | 0       | 1       | 1       | March 2/4           | Swing 4/4           |
| 5                  | 1       | 0       | 1       | 0       | Swing 4/4           | Mambo 4/4           |
| 6                  | 1       | 0       | 0       | 1       | Foxtrot 4/4         | Slow Rock 6/8       |
| 7                  | 1       | 0       | 0       | 0       | Slow Rock 6/8       | Beat 4/4            |
| 8                  | 0       | 1       | 1       | 1       | Pop Rock 4/4        | Samba 4/4           |
| 9                  | 0       | 1       | 1       | 0       | Shuffle 2/4         | Bossa Nova 4/4      |
| 10                 | 0       | 1       | 0       | 1       | Mambo 4/4           | Cha Cha 4/4         |
| 11                 | 0       | 1       | 0       | 0       | Beguine 4/4         | Rhumba 4/4          |
| 12                 | 0       | 0       | 1       | 1       | Cha Cha 4/4         | Beguine 4/4         |
| 13                 | 0       | 0       | 1       | 0       | Bajon 4/4           | Bajon 4/4           |
| 14                 | 0       | 0       | 0       | 1       | Samba 4/4           | Foxtrot 4/4         |
| 15                 | 0       | 0       | 0       | 0       | Bossa Nova 4/4      | Shuffle 2/4         |
| No selected rhythm | 1       | 1       | 1       | 1       |                     |                     |

## BLOCK DIAGRAM

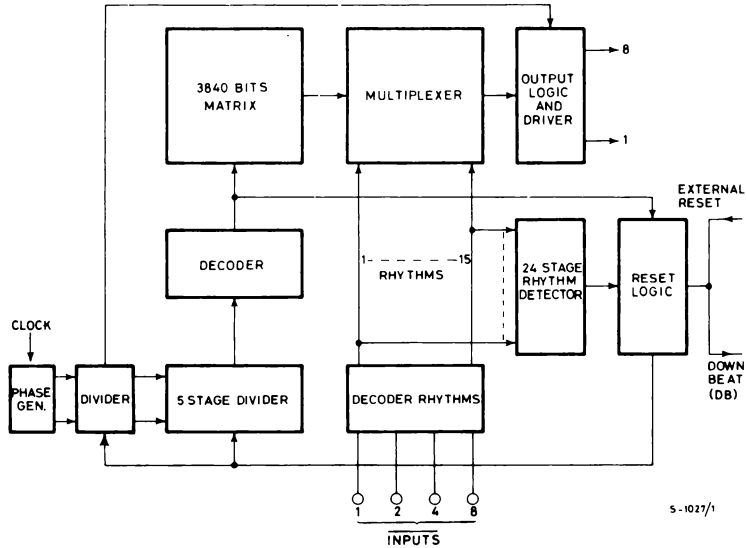

## STATIC ELECTRICAL CHARACTERISTICS (positive logic, $V_{GG} = -11.4$ to $-12.6V$ , $V_{SS} = 4.75$ to $5.25V$ , $T_{amb} = 0$ to $70^{\circ}C$ unless otherwise specified)

| Parameter | Test conditions | Values |      |      | Unit |
|-----------|-----------------|--------|------|------|------|
|           |                 | Min.   | Typ. | Max. |      |

### CLOCK INPUT

|          |                    |  |              |  |              |   |
|----------|--------------------|--|--------------|--|--------------|---|
| $V_{IH}$ | Clock high voltage |  | $V_{SS}-1.5$ |  | $V_{SS}$     | V |
| $V_{IL}$ | Clock low voltage  |  | $V_{GG}$     |  | $V_{SS}-4.1$ | V |

### DATA INPUTS ( $\overline{IN1} \dots \overline{IN8}$ )

|          |                       |   |              |  |              |         |
|----------|-----------------------|---|--------------|--|--------------|---------|
| $V_{IH}$ | Input high voltage    |   | $V_{SS}-1.5$ |  | $V_{SS}$     | V       |
| $V_{IL}$ | Input low voltage     |   | $V_{GG}$     |  | $V_{SS}-4.1$ | V       |
| $I_{LI}$ | Input leakage current | $V_i = V_{SS}-10V$<br>$T_{amb} = 25^{\circ}C$ |              |  | 10           | $\mu A$ |

### EXTERNAL RESET

|          |                                 |                   |              |     |              |           |
|----------|---------------------------------|-------------------|--------------|-----|--------------|-----------|
| $V_{IH}$ | Input high voltage              |                   | $V_{SS}-1.5$ |     | $V_{SS}$     | V         |
| $V_{IL}$ | Input low voltage               |                   | $V_{GG}$     |     | $V_{SS}-4.1$ | V         |
| $R_{IN}$ | Internal resistance to $V_{GG}$ | $V_o = V_{SS}-5V$ | 400          | 600 |              | $K\Omega$ |

### DATA OUTPUTS

|          |                              |   |                    |     |          |          |
|----------|------------------------------|---|--------------------|-----|----------|----------|
| $R_{ON}$ | Output resistance (ON state) | $V_o = V_{SS}-1$ to $V_{SS}$              |                    | 250 | 500      | $\Omega$ |
| $V_{OH}$ | Output high voltage          | $I_L = 1$ mA                              | $V_{SS}-0.5$       |     | $V_{SS}$ | V        |
| $I_{LO}$ | Output leakage current       | $V_i = V_{IH}$<br>$T_{amb} = 25^{\circ}C$ | $V_o = V_{SS}-10V$ |     | 10       | $\mu A$  |

### POWER DISSIPATION

|          |                |                         |  |   |    |    |
|----------|----------------|-------------------------|--|---|----|----|
| $I_{GG}$ | Supply current | $T_{amb} = 25^{\circ}C$ |  | 7 | 15 | mA |
|----------|----------------|-------------------------|--|---|----|----|

# M 252

Output voltage vs. external supply voltage ( $V_{EXT}-V_{SS}$ )

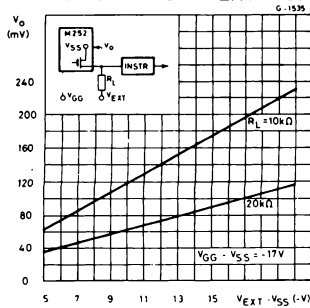

Output voltage vs. supply voltage ( $V_{GG}-V_{SS}$ )

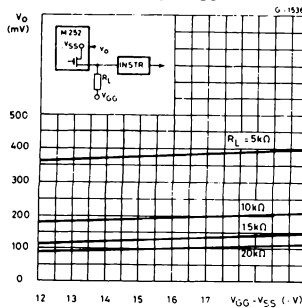

Output dynamic resistance vs. output voltage

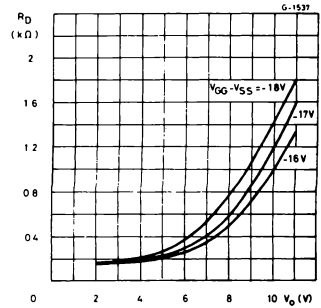

**DYNAMIC ELECTRICAL CHARACTERISTICS** (positive logic  $V_{GG} = -11.4$  to  $-12.6V$ ,  $V_{SS} = 4.75$  to  $5.25V$ ,  $T_{amb} = 0$  to  $70^\circ C$  unless otherwise specified)

| Parameter | Test conditions | Values |      |      | Unit |
|-----------|-----------------|--------|------|------|------|
|           |                 | Min.   | Typ. | Max. |      |

## CLOCK INPUT

| Parameter  | Test conditions       | Min. | Typ. | Max. | Unit    |
|------------|-----------------------|------|------|------|---------|
| f          | Clock repetition rate | DC   |      | 100  | kHz     |
| $t_{pw}^*$ | Pulse width           | 5    |      |      | $\mu s$ |
| $t_r^{**}$ | Rise time             |      |      | 100  | $\mu s$ |
| $t_f^{**}$ | Fall time             |      |      | 100  | $\mu s$ |

## EXTERNAL RESET

| Parameter | Test conditions | Min. | Typ. | Max. | Unit    |
|-----------|-----------------|------|------|------|---------|
| $t_{pw}$  | Pulse width     | 5    |      |      | $\mu s$ |

\* Measured at 50% of the swing.

\*\* Measured between 10% and 90% of the swing.



## TYPICAL APPLICATIONS

Figure 1 shows the typical application of the M252 (AA) and M252 (AD). With two M252 devices it is possible to increase the number of rhythms or the number of instruments available, or the number of elementary times, as shown in figures 2, 3 and 4 respectively. The use of a memory matrix allows the customer complete flexibility, since modification of the memory is quick and relatively cheap.

Fig. 1 - Rhythm system (standard contents)

### a) M252 AA

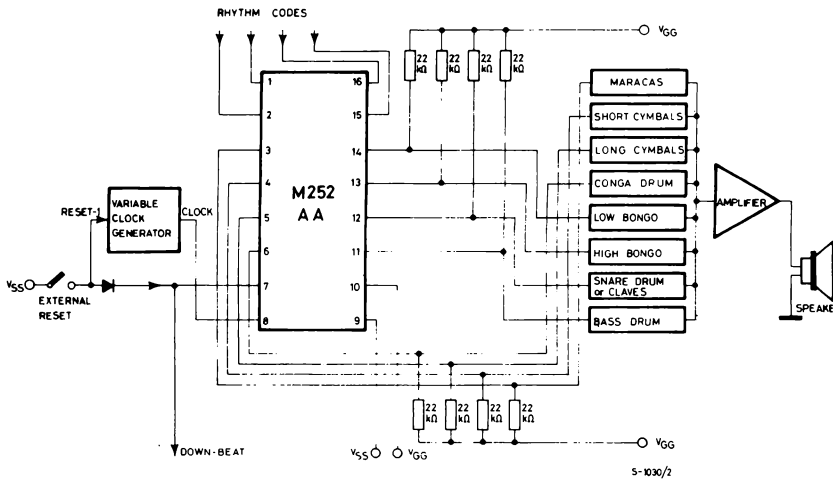

### b) M252 AD

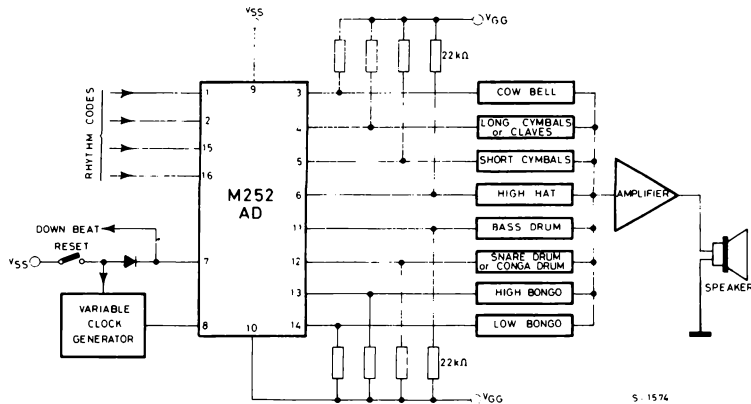

## TYPICAL APPLICATIONS (continued)

Fig. 2 - Increase in number of rhythms (positive logic)

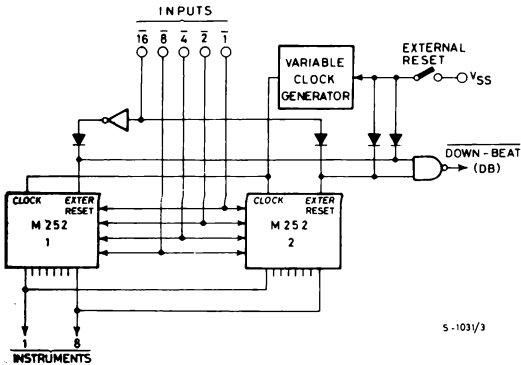

Fig. 3 - Increase in number of instruments

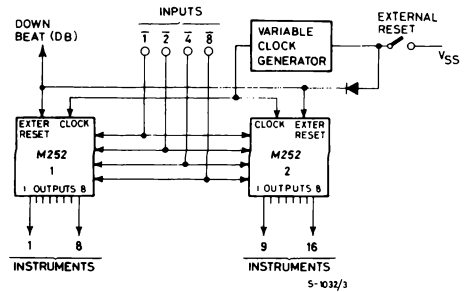
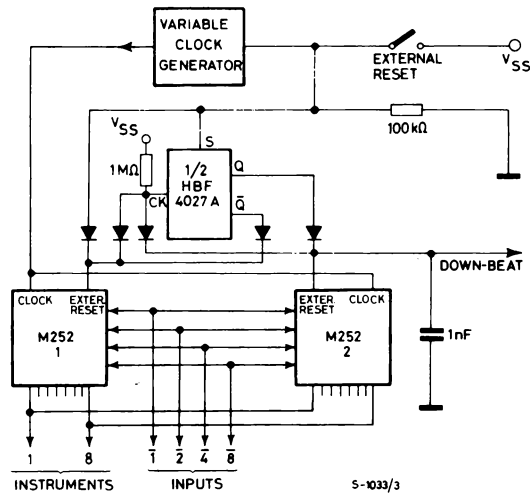
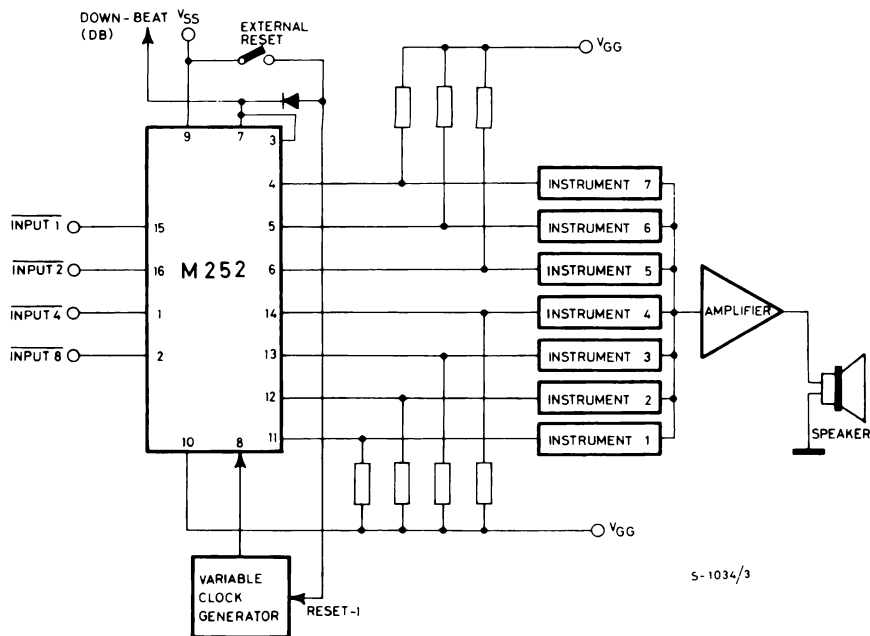

Fig. 4 - Increasing the number of elementary times



Note: The total number of elementary times is given by the sum of the elementary times of the individual devices.

## CIRCUIT FOR CHANGING THE NUMBER OF ELEMENTARY TIMES



s-1034/3

To obtain a required number of elementary times "N" simply put a cross in the "N + 1" position of the column which now represents the reset output, rather than the 8th instrument.

The DB output can be used as down-beat because it appears at the beginning of each measure. Since the pulse is only 2 - 3  $\mu$ s long it must, however, be stretched and buffered to enable it to drive a lamp.

**Full information on the use of the M252 in electronic organs and other applications will be found in Technical Note no. 131 available on request.**

### COMPLETING THE TRUTH TABLE

The ROM truth table has been organized in 32 rows which represent elementary times and 120 columns (15 groups of 8) where each group represents a rhythm which has as its disposition 8 programmable instruments. To programme each rhythm one indicates (with a cross) in the appropriate boxes the timing for each beat required for each instrument.

Each cross corresponds to a beat of the indicated instrument or, in logic terms, to the presence of a "1" level (positive logic) at the output.

The absence of a cross indicates that the corresponding instrument is not used in that part of the rhythm. Table 1 and 2 show the standard music content programmed into M252 AA and M252 AD respectively.



**TABLE 1 (M252 AA)**

| COUNT FOR 32 | RHYTHM 1      |               |               |               |               |               |               |               | RHYTHM 2      |               |               |               |               |               |               |               | RHYTHM 3      |               |               |               |               |               |               |               | RHYTHM 4      |               |               |               |               |               |               |               | RHYTHM 5      |               |               |               |               |               |               |               |
|--------------|---------------|---------------|---------------|---------------|---------------|---------------|---------------|---------------|---------------|---------------|---------------|---------------|---------------|---------------|---------------|---------------|---------------|---------------|---------------|---------------|---------------|---------------|---------------|---------------|---------------|---------------|---------------|---------------|---------------|---------------|---------------|---------------|---------------|---------------|---------------|---------------|---------------|---------------|---------------|---------------|
|              | O U T P U T 1 | O U T P U T 2 | O U T P U T 3 | O U T P U T 4 | O U T P U T 5 | O U T P U T 6 | O U T P U T 7 | O U T P U T 8 | O U T P U T 1 | O U T P U T 2 | O U T P U T 3 | O U T P U T 4 | O U T P U T 5 | O U T P U T 6 | O U T P U T 7 | O U T P U T 8 | O U T P U T 1 | O U T P U T 2 | O U T P U T 3 | O U T P U T 4 | O U T P U T 5 | O U T P U T 6 | O U T P U T 7 | O U T P U T 8 | O U T P U T 1 | O U T P U T 2 | O U T P U T 3 | O U T P U T 4 | O U T P U T 5 | O U T P U T 6 | O U T P U T 7 | O U T P U T 8 | O U T P U T 1 | O U T P U T 2 | O U T P U T 3 | O U T P U T 4 | O U T P U T 5 | O U T P U T 6 | O U T P U T 7 | O U T P U T 8 |
| 1            | X             |               |               |               |               | X             |               | X             |               |               |               |               |               |               |               | X             | X             |               |               |               |               |               |               | X             |               |               |               |               |               |               |               |               |               |               |               | X             |               |               |               |               |
| 2            |               |               |               |               |               |               |               |               |               |               |               |               |               |               |               |               |               |               |               |               |               |               |               |               |               |               |               |               |               |               |               |               |               |               |               |               |               |               |               |               |
| 3            |               |               |               |               |               |               |               |               |               |               |               |               |               |               |               |               |               |               |               |               |               |               |               |               |               |               |               |               |               |               |               |               |               |               |               |               |               |               |               |               |
| 4            |               |               |               |               |               |               |               |               |               | X             |               |               |               |               |               |               |               |               |               |               |               |               |               |               |               |               |               |               |               |               |               |               |               |               |               |               |               |               |               |               |
| 5            |               | X             |               |               |               |               |               |               |               | X             |               |               |               |               |               |               | X             | X             |               |               |               |               |               |               |               |               |               |               |               |               |               |               |               |               |               | X             |               |               |               |               |
| 6            |               |               |               |               |               |               |               |               |               |               |               |               |               |               |               |               |               |               |               |               |               |               |               |               |               |               |               |               |               |               |               |               |               |               |               |               |               |               |               |               |
| 7            |               |               |               |               |               |               |               |               |               |               |               |               |               |               |               |               |               |               |               |               |               |               |               |               |               |               |               |               |               |               |               |               |               |               |               |               |               |               |               |               |
| 8            |               |               |               |               |               |               |               |               |               |               |               |               |               |               |               |               |               |               |               |               |               |               |               |               |               |               |               |               |               |               |               |               |               |               |               |               | X             |               |               |               |
| 9            |               | X             |               |               |               |               |               |               |               | X             |               |               |               |               |               | X             | X             |               |               |               |               |               |               | X             |               |               | X             |               |               |               |               |               |               |               | X             |               |               |               |               |               |
| 10           |               |               |               |               |               |               |               |               |               |               |               |               |               |               |               |               |               |               |               |               |               |               |               |               |               |               |               |               |               |               |               |               |               |               |               |               |               |               |               |               |
| 11           |               |               |               |               |               |               |               |               |               |               |               |               |               |               |               |               |               |               |               |               |               |               |               |               |               |               |               |               |               |               |               |               |               |               |               |               |               |               |               |               |
| 12           |               |               |               |               |               |               |               |               |               |               |               |               |               |               |               |               |               |               |               |               |               |               |               |               |               |               |               |               |               |               |               |               |               |               |               |               |               |               |               |               |
| 13           |               | X             |               |               |               | X             |               | X             |               |               |               |               |               |               |               |               | X             | X             |               |               |               |               |               |               |               |               |               |               |               |               |               |               |               | X             |               | X             |               |               |               |               |
| 14           |               |               |               |               |               |               |               |               |               |               |               |               |               |               |               |               |               |               |               |               |               |               |               |               |               |               |               |               |               |               |               |               |               |               |               |               |               |               |               |               |
| 15           |               | X             |               |               |               |               |               |               |               |               |               |               |               |               |               |               | X             | X             |               |               |               |               |               |               |               |               |               |               |               |               |               |               |               |               |               |               |               |               |               |               |
| 16           |               |               |               |               |               |               |               |               |               | X             |               |               |               |               |               |               |               |               |               |               |               |               |               |               |               |               |               |               |               |               |               |               |               |               |               |               | X             |               |               |               |
| 17           |               | X             |               |               |               |               |               |               |               | X             |               |               |               |               |               |               | X             | X             |               |               |               |               |               |               |               |               |               |               |               |               |               |               |               |               |               | X             |               |               |               |               |
| 18           |               |               |               |               |               |               |               |               |               |               |               |               |               |               |               |               |               |               |               |               |               |               |               |               |               |               |               |               |               |               |               |               |               |               |               |               |               |               |               |               |
| 19           |               |               |               |               |               |               |               |               |               |               |               |               |               |               |               |               |               |               |               |               |               |               |               |               |               |               |               |               |               |               |               |               |               |               |               |               |               |               |               |               |
| 20           |               |               |               |               |               |               |               |               |               | X             |               |               |               |               |               |               |               |               |               |               |               |               |               |               |               |               |               |               |               |               |               |               |               |               |               |               |               |               |               |               |
| 21           |               | X             |               |               |               |               |               |               |               | X             |               |               |               |               |               |               | X             | X             |               |               |               |               |               |               |               |               |               |               |               |               |               |               |               |               |               |               |               |               |               |               |
| 22           |               |               |               |               |               |               |               |               |               |               |               |               |               |               |               |               |               |               |               |               |               |               |               |               |               |               |               |               |               |               |               |               |               |               |               |               |               |               |               |               |
| 23           |               |               |               |               |               |               |               |               |               |               |               |               |               |               |               |               |               |               |               |               |               |               |               |               |               |               |               |               |               |               |               |               |               |               |               |               |               |               |               |               |
| 24           |               |               |               |               |               |               |               |               | X             |               |               |               |               |               |               | X             |               |               |               |               |               |               |               |               |               |               |               |               |               |               |               |               |               |               |               | X             |               |               |               |               |
| 25           |               |               |               |               |               |               |               |               |               |               |               |               |               |               |               | X             | X             |               |               |               |               |               |               |               |               |               |               |               |               |               |               |               |               |               | X             | X             |               |               |               |               |
| 26           |               |               |               |               |               |               |               |               |               |               |               |               |               |               |               |               |               |               |               |               |               |               |               |               |               |               |               |               |               |               |               |               |               |               |               |               |               |               |               |               |
| 27           |               |               |               |               |               |               |               |               |               |               |               |               |               |               |               |               |               |               |               |               |               |               |               |               |               |               |               |               |               |               |               |               |               |               |               |               |               |               |               |               |
| 28           |               |               |               |               |               |               |               |               |               |               |               |               |               |               |               |               |               |               |               |               |               |               |               |               |               |               |               |               |               |               |               |               |               |               |               |               |               |               |               |               |
| 29           |               |               |               |               |               |               |               |               |               |               |               |               |               |               |               |               |               |               |               |               |               |               |               |               |               |               |               |               |               |               |               |               |               |               |               |               |               |               |               |               |
| 30           |               |               |               |               |               |               |               |               |               |               |               |               |               |               |               |               |               |               |               |               |               |               |               |               |               |               |               |               |               |               |               |               |               |               |               |               |               |               |               |               |
| 31           |               |               |               |               |               |               |               |               |               |               |               |               |               |               |               |               |               |               |               |               |               |               |               |               |               |               |               |               |               |               |               |               |               |               |               |               |               |               |               |               |
| 32           |               |               |               |               |               |               |               |               |               |               |               |               |               |               |               |               | X             | X             |               |               |               |               |               |               |               |               |               |               |               |               |               |               |               |               |               | X             |               |               |               |               |

| COUNT FOR 32 | RHYTHM 6      |               |               |               |               |               |               |               | RHYTHM 7      |               |               |               |               |               |               |               | RHYTHM 8      |               |               |               |               |               |               |               | RHYTHM 9      |               |               |               |               |               |               |               | RHYTHM 10     |               |               |               |               |               |               |               |
|--------------|---------------|---------------|---------------|---------------|---------------|---------------|---------------|---------------|---------------|---------------|---------------|---------------|---------------|---------------|---------------|---------------|---------------|---------------|---------------|---------------|---------------|---------------|---------------|---------------|---------------|---------------|---------------|---------------|---------------|---------------|---------------|---------------|---------------|---------------|---------------|---------------|---------------|---------------|---------------|---------------|
|              | O U T P U T 1 | O U T P U T 2 | O U T P U T 3 | O U T P U T 4 | O U T P U T 5 | O U T P U T 6 | O U T P U T 7 | O U T P U T 8 | O U T P U T 1 | O U T P U T 2 | O U T P U T 3 | O U T P U T 4 | O U T P U T 5 | O U T P U T 6 | O U T P U T 7 | O U T P U T 8 | O U T P U T 1 | O U T P U T 2 | O U T P U T 3 | O U T P U T 4 | O U T P U T 5 | O U T P U T 6 | O U T P U T 7 | O U T P U T 8 | O U T P U T 1 | O U T P U T 2 | O U T P U T 3 | O U T P U T 4 | O U T P U T 5 | O U T P U T 6 | O U T P U T 7 | O U T P U T 8 | O U T P U T 1 | O U T P U T 2 | O U T P U T 3 | O U T P U T 4 | O U T P U T 5 | O U T P U T 6 | O U T P U T 7 | O U T P U T 8 |
| 1            | X             |               |               |               |               |               |               | X             | X             |               |               |               |               |               |               | X             | X             |               |               |               |               |               |               |               |               |               |               |               |               |               |               |               |               |               |               |               | X             |               |               |               |
| 2            |               |               |               |               |               |               |               |               |               |               |               |               |               |               |               |               |               |               |               |               |               |               |               |               |               |               |               |               |               |               |               |               |               |               |               |               |               |               |               |               |
| 3            |               |               |               |               |               |               |               |               |               |               |               |               |               |               |               |               |               |               |               |               |               |               |               |               |               |               |               |               |               |               |               |               |               |               |               |               |               |               |               |               |
| 4            |               |               |               |               |               |               |               |               |               |               |               |               |               |               |               |               |               |               |               |               |               |               |               |               |               |               |               |               |               |               |               |               |               |               |               |               |               |               |               |               |
| 5            |               | X             |               |               |               |               |               |               |               |               |               |               |               |               |               |               |               |               |               |               |               |               |               |               |               |               |               |               |               |               |               |               |               |               |               |               |               |               |               |               |
| 6            |               |               |               |               |               |               |               |               |               |               |               |               |               |               |               |               |               |               |               |               |               |               |               |               |               |               |               |               |               |               |               |               |               |               |               |               |               |               |               |               |
| 7            |               |               |               |               |               |               |               |               |               | X             |               |               |               |               |               |               |               |               |               |               |               |               |               |               |               |               |               |               |               |               |               |               |               |               |               |               |               |               |               |               |
| 8            |               |               |               |               |               |               |               |               |               |               |               |               |               |               |               |               |               |               |               |               |               |               |               |               |               |               |               |               |               |               |               |               |               |               |               |               |               |               |               |               |
| 9            |               | X             |               |               |               |               |               |               |               |               |               |               |               |               |               |               |               |               |               |               |               |               |               |               |               |               |               |               |               |               |               |               |               |               |               |               |               |               |               |               |
| 10           |               |               |               |               |               |               |               |               |               |               |               |               |               |               |               |               |               |               |               |               |               |               |               |               |               |               |               |               |               |               |               |               |               |               |               |               |               |               |               |               |
| 11           |               |               |               |               |               |               |               |               |               |               |               |               |               |               |               |               |               |               |               |               |               |               |               |               |               |               |               |               |               |               |               |               |               |               |               |               |               |               |               |               |
| 12           |               |               |               |               |               |               |               |               |               |               |               |               |               |               |               |               |               |               |               |               |               |               |               |               |               |               |               |               |               |               |               |               |               |               |               |               |               |               |               |               |
| 13           |               | X             |               |               |               |               |               |               |               | X             | X             |               |               |               |               |               |               |               |               |               |               |               |               |               |               |               |               |               |               |               |               |               |               |               |               |               |               |               |               |               |
| 14           |               |               |               |               |               |               |               |               |               |               |               |               |               |               |               |               |               |               |               |               |               |               |               |               |               |               |               |               |               |               |               |               |               |               |               |               |               |               |               |               |
| 15           |               | X             |               |               |               |               |               |               |               |               |               |               |               |               |               |               |               |               |               |               |               |               |               |               |               |               |               |               |               |               |               |               |               |               |               |               |               |               |               |               |
| 16           |               |               |               |               |               |               |               |               |               |               |               |               |               |               |               |               |               |               |               |               |               |               |               |               |               |               |               |               |               |               |               |               |               |               |               |               |               |               |               |               |
| 17           |               | X             |               |               |               |               |               |               |               |               |               |               |               |               |               |               |               |               |               |               |               |               |               |               |               |               |               |               |               |               |               |               |               |               |               |               |               |               |               |               |
| 18           |               |               |               |               |               |               |               |               |               |               |               |               |               |               |               |               |               |               |               |               |               |               |               |               |               |               |               |               |               |               |               |               |               |               |               |               |               |               |               |               |
| 19           |               |               |               |               |               |               |               |               |               |               |               |               |               |               |               |               |               |               |               |               |               |               |               |               |               |               |               |               |               |               |               |               |               |               |               |               |               |               |               |               |
| 20           |               |               |               |               |               |               |               |               |               |               |               |               |               |               |               |               |               |               |               |               |               |               |               |               |               |               |               |               |               |               |               |               |               |               |               |               |               |               |               |               |
| 21           |               | X             |               |               |               |               |               |               |               |               |               |               |               |               |               |               |               |               |               |               |               |               |               |               |               |               |               |               |               |               |               |               |               |               |               |               |               |               |               |               |
| 22           |               |               |               |               |               |               |               |               |               |               |               |               |               |               |               |               |               |               |               |               |               |               |               |               |               |               |               |               |               |               |               |               |               |               |               |               |               |               |               |               |
| 23           |               |               |               |               |               |               |               |               |               |               |               |               |               |               |               |               |               |               |               |               |               |               |               |               |               |               |               |               |               |               |               |               |               |               |               |               |               |               |               |               |
| 24           |               |               |               |               |               |               |               |               |               |               |               |               |               |               |               |               |               |               |               |               |               |               |               |               |               |               |               |               |               |               |               |               |               |               |               |               |               |               |               |               |
| 25           |               | X             |               |               |               |               |               |               |               |               |               |               |               |               |               |               |               |               |               |               |               |               |               |               |               |               |               |               |               |               |               |               |               |               |               |               |               |               |               |               |
| 26           |               |               |               |               |               |               |               |               |               |               |               |               |               |               |               |               |               |               |               |               |               |               |               |               |               |               |               |               |               |               |               |               |               |               |               |               |               |               |               |               |
| 27           |               |               |               |               |               |               |               |               |               |               |               |               |               |               |               |               |               |               |               |               |               |               |               |               |               |               |               |               |               |               |               |               |               |               |               |               |               |               |               |               |
| 28           |               |               |               |               |               |               |               |               |               |               |               |               |               |               |               |               |               |               |               |               |               |               |               |               |               |               |               |               |               |               |               |               |               |               |               |               |               |               |               |               |
| 29           |               | X             |               |               |               |               |               |               |               |               |               |               |               |               |               |               |               |               |               |               |               |               |               |               |               |               |               |               |               |               |               |               |               |               |               |               |               |               |               |               |
| 30           |               |               |               |               |               |               |               |               |               |               |               |               |               |               |               |               |               |               |               |               |               |               |               |               |               |               |               |               |               |               |               |               |               |               |               |               |               |               |               |               |
| 31           |               |               |               |               |               |               |               |               |               |               |               |               |               |               |               |               |               |               |               |               |               |               |               |               |               |               |               |               |               |               |               |               |               |               |               |               |               |               |               |               |
| 32           |               |               |               |               |               |               |               |               |               |               |               |               |               |               |               |               |               |               |               |               |               |               |               |               |               |               |               |               |               |               |               |               |               |               |               |               |               |               |               |               |

# M 252

| COUNT FOR 32 | RHYTHM 11 |           |           |           |           |           |           |           | RHYTHM 12 |           |           |           |           |           |           |           | RHYTHM 13 |           |           |           |           |           |           |           | RHYTHM 14 |           |           |           |           |           |           |           | RHYTHM 15 |           |           |           |           |           |           |           |
|--------------|-----------|-----------|-----------|-----------|-----------|-----------|-----------|-----------|-----------|-----------|-----------|-----------|-----------|-----------|-----------|-----------|-----------|-----------|-----------|-----------|-----------|-----------|-----------|-----------|-----------|-----------|-----------|-----------|-----------|-----------|-----------|-----------|-----------|-----------|-----------|-----------|-----------|-----------|-----------|-----------|
|              | OUT PUT 1 | OUT PUT 2 | OUT PUT 3 | OUT PUT 4 | OUT PUT 5 | OUT PUT 6 | OUT PUT 7 | OUT PUT 8 | OUT PUT 1 | OUT PUT 2 | OUT PUT 3 | OUT PUT 4 | OUT PUT 5 | OUT PUT 6 | OUT PUT 7 | OUT PUT 8 | OUT PUT 1 | OUT PUT 2 | OUT PUT 3 | OUT PUT 4 | OUT PUT 5 | OUT PUT 6 | OUT PUT 7 | OUT PUT 8 | OUT PUT 1 | OUT PUT 2 | OUT PUT 3 | OUT PUT 4 | OUT PUT 5 | OUT PUT 6 | OUT PUT 7 | OUT PUT 8 | OUT PUT 1 | OUT PUT 2 | OUT PUT 3 | OUT PUT 4 | OUT PUT 5 | OUT PUT 6 | OUT PUT 7 | OUT PUT 8 |
| 1            | X         |           |           |           |           |           |           | X         | X         | X         | X         |           |           |           |           | X         | X         | X         | X         |           |           |           |           | X         | X         | X         | X         |           |           |           |           |           |           |           |           | X         |           |           |           |           |
| 2            |           |           |           |           |           |           |           |           |           |           |           |           |           |           |           | X         |           |           |           |           |           |           |           |           | X         |           |           |           |           |           |           |           |           |           |           | X         |           |           |           |           |
| 3            |           | X         | X         | X         |           |           |           | X         | X         |           |           |           |           |           |           | X         |           |           |           |           |           |           |           | X         |           |           |           |           |           |           |           |           |           |           |           | X         |           |           |           |           |
| 4            |           |           |           |           |           |           |           | X         |           |           |           |           |           |           |           |           |           |           |           |           |           |           |           |           |           |           |           |           |           |           |           |           |           |           |           | X         |           |           |           |           |
| 5            |           |           |           |           |           |           |           | X         | X         |           |           |           |           |           |           | X         |           |           |           |           |           |           |           |           |           |           |           |           |           |           |           |           |           |           |           | X         |           |           |           |           |
| 6            |           |           |           |           |           |           |           |           |           |           |           |           |           |           |           |           |           |           |           |           |           |           |           |           |           |           |           |           |           |           |           |           |           |           |           | X         |           |           |           |           |
| 7            |           | X         | X         |           |           |           |           | X         | X         |           |           |           |           |           |           | X         | X         | X         |           |           |           |           |           | X         |           |           |           |           |           |           |           |           |           |           |           | X         |           |           |           |           |
| 8            |           |           |           |           |           |           |           |           |           |           |           |           |           |           |           |           |           |           |           |           |           |           |           |           |           |           |           |           |           |           |           |           |           |           |           | X         |           |           |           |           |
| 9            | X         |           |           |           |           |           |           | X         | X         | X         | X         |           |           |           |           | X         | X         | X         |           |           |           |           |           | X         | X         | X         | X         |           |           |           |           |           |           |           |           | X         |           |           |           |           |
| 10           |           |           |           |           |           |           |           |           |           |           |           |           |           |           |           |           |           |           |           |           |           |           |           |           | X         | X         | X         | X         |           |           |           |           |           |           |           |           | X         |           |           |           |
| 11           |           | X         | X         |           |           |           |           | X         |           |           |           |           |           |           |           | X         |           |           |           |           |           |           |           | X         |           |           |           |           |           |           |           |           |           |           |           | X         |           |           |           |           |
| 12           |           |           |           |           |           |           |           |           |           |           |           |           |           |           |           |           |           |           |           |           |           |           |           |           |           |           |           |           |           |           |           |           |           |           |           | X         |           |           |           |           |
| 13           | X         |           |           |           |           |           |           | X         | X         | X         | X         | X         |           |           |           | X         | X         | X         |           |           |           |           |           | X         | X         | X         |           |           |           |           |           |           |           |           |           | X         |           |           |           |           |
| 14           |           |           |           |           |           |           |           |           |           |           |           |           |           |           |           |           |           |           |           |           |           |           |           |           |           |           |           |           |           |           |           |           |           |           |           | X         |           |           |           |           |
| 15           |           | X         | X         |           |           |           |           | X         | X         | X         | X         |           |           |           |           | X         |           | X         |           |           |           |           |           | X         | X         | X         |           |           |           |           |           |           |           |           |           | X         |           |           |           |           |
| 16           |           |           |           |           |           |           |           |           |           |           |           |           |           |           |           |           |           |           |           |           |           |           |           |           |           |           |           |           |           |           |           |           |           |           |           | X         |           |           |           |           |
| 17           | X         |           |           |           |           |           |           | X         | X         | X         | X         |           |           |           |           | X         | X         | X         | X         |           |           |           |           | X         | X         |           |           |           |           |           |           |           |           |           |           | X         |           |           |           |           |
| 18           |           | X         | X         | X         |           |           |           | X         | X         |           |           |           |           |           |           | X         |           |           |           |           |           |           |           | X         | X         | X         | X         |           |           |           |           |           |           |           |           | X         |           |           |           |           |
| 19           |           |           |           |           |           |           |           |           |           |           |           |           |           |           |           |           |           |           |           |           |           |           |           |           | X         | X         | X         |           |           |           |           |           |           |           |           | X         |           |           |           |           |
| 20           |           |           |           |           |           |           |           | X         | X         | X         |           |           |           |           |           |           |           |           |           |           |           |           |           |           |           |           |           |           |           |           |           |           |           |           |           | X         |           |           |           |           |
| 21           |           |           |           |           |           |           |           | X         | X         | X         | X         |           |           |           |           | X         |           |           |           |           |           |           |           |           |           |           |           |           |           |           |           |           |           |           |           | X         |           |           |           |           |
| 22           |           |           |           |           |           |           |           |           |           |           |           |           |           |           |           |           |           |           |           |           |           |           |           |           |           |           |           |           |           |           |           |           |           |           |           | X         |           |           |           |           |
| 23           | X         | X         |           |           | X         |           |           | X         | X         |           |           |           |           |           |           | X         | X         | X         | X         |           |           |           |           | X         | X         | X         |           |           |           |           |           |           |           |           | X         |           |           |           |           |           |
| 24           |           |           |           |           |           |           |           |           |           |           |           |           |           |           |           |           |           |           |           |           |           |           |           |           |           |           |           |           |           |           |           |           |           |           |           | X         |           |           |           |           |
| 25           | X         |           |           |           |           |           |           | X         | X         | X         | X         |           |           |           |           | X         | X         | X         | X         |           |           |           |           | X         | X         | X         | X         |           |           |           |           |           |           |           |           | X         |           |           |           |           |
| 26           |           |           |           |           |           |           |           |           |           |           |           |           |           |           |           |           |           |           |           |           |           |           |           |           |           |           |           |           |           |           |           |           |           |           |           | X         |           |           |           |           |
| 27           |           | X         | X         |           |           |           |           | X         |           |           |           |           |           |           |           | X         |           |           |           |           |           |           |           | X         |           |           |           |           |           |           |           |           |           |           |           | X         |           |           |           |           |
| 28           |           |           |           |           |           |           |           |           |           |           |           |           |           |           |           |           |           |           |           |           |           |           |           |           |           |           |           |           |           |           |           |           |           |           |           | X         |           |           |           |           |
| 29           | X         |           |           |           |           |           |           | X         | X         | X         | X         | X         |           |           |           | X         | X         | X         |           |           |           |           |           | X         | X         |           |           |           |           |           |           |           |           |           |           | X         |           |           |           |           |
| 30           |           |           |           |           |           |           |           |           |           |           |           |           |           |           |           |           |           |           |           |           |           |           |           |           |           |           |           |           |           |           |           |           |           |           |           | X         |           |           |           |           |
| 31           | X         | X         |           |           |           |           |           | X         | X         | X         | X         |           |           |           |           | X         |           | X         |           |           |           |           |           |           |           |           |           |           |           |           |           |           |           |           |           | X         |           |           |           |           |
| 32           |           |           |           |           |           |           |           |           |           |           |           |           |           |           |           |           |           |           |           |           |           |           |           |           |           |           |           |           |           |           |           |           |           |           |           | X         |           |           |           |           |

TABLE 2(M252 AD)

| COUNT FOR 32 | RHYTHM 1 (WALTZ) |           |           |           |           |           |           |           | RHYTHM 2 (TANGO) |           |           |           |           |           |           |           | RHYTHM 3 (MARCH) |           |           |           |           |           |           |           | RHYTHM 4 (SWING) |           |           |           |           |           |           |           | RHYTHM 5 (MAMBO) |           |           |           |           |           |           |           |
|--------------|------------------|-----------|-----------|-----------|-----------|-----------|-----------|-----------|------------------|-----------|-----------|-----------|-----------|-----------|-----------|-----------|------------------|-----------|-----------|-----------|-----------|-----------|-----------|-----------|------------------|-----------|-----------|-----------|-----------|-----------|-----------|-----------|------------------|-----------|-----------|-----------|-----------|-----------|-----------|-----------|
|              | OUT PUT 1        | OUT PUT 2 | OUT PUT 3 | OUT PUT 4 | OUT PUT 5 | OUT PUT 6 | OUT PUT 7 | OUT PUT 8 | OUT PUT 1        | OUT PUT 2 | OUT PUT 3 | OUT PUT 4 | OUT PUT 5 | OUT PUT 6 | OUT PUT 7 | OUT PUT 8 | OUT PUT 1        | OUT PUT 2 | OUT PUT 3 | OUT PUT 4 | OUT PUT 5 | OUT PUT 6 | OUT PUT 7 | OUT PUT 8 | OUT PUT 1        | OUT PUT 2 | OUT PUT 3 | OUT PUT 4 | OUT PUT 5 | OUT PUT 6 | OUT PUT 7 | OUT PUT 8 | OUT PUT 1        | OUT PUT 2 | OUT PUT 3 | OUT PUT 4 | OUT PUT 5 | OUT PUT 6 | OUT PUT 7 | OUT PUT 8 |
| 1            | X                |           |           |           |           |           |           | X         | X                |           |           |           |           |           |           | X         |                  |           |           |           |           |           | X         | X         | X                | X         |           |           |           |           |           |           |                  |           | X         |           |           |           |           |           |
| 2            |                  |           |           |           |           |           |           |           |                  |           |           |           |           |           |           |           |                  |           |           |           |           |           |           |           |                  |           |           |           |           |           |           |           |                  |           |           | X         |           |           |           |           |
| 3            |                  |           |           |           |           |           |           |           |                  |           |           |           |           |           |           |           |                  |           |           |           |           |           |           |           |                  |           |           |           |           |           |           |           |                  |           |           | X         |           |           |           |           |
| 4            |                  |           |           |           |           |           |           |           |                  |           |           |           |           |           |           |           |                  |           |           |           |           |           |           |           |                  |           |           |           |           |           |           |           |                  |           |           | X         |           |           |           |           |
| 5            |                  | X         |           |           |           |           |           |           |                  |           |           |           |           |           |           |           |                  |           |           |           |           |           |           |           |                  |           |           |           |           |           |           |           |                  |           |           | X         |           |           |           |           |
| 6            |                  |           |           |           |           |           |           |           |                  |           |           |           |           |           |           |           |                  |           |           |           |           |           |           |           |                  |           |           |           |           |           |           |           |                  |           |           | X         |           |           |           |           |
| 7            |                  |           |           |           |           |           |           |           |                  |           |           |           |           |           |           |           |                  |           |           |           |           |           |           |           |                  |           |           |           |           |           |           |           |                  |           |           | X         |           |           |           |           |
| 8            |                  |           |           |           |           |           |           |           |                  |           |           |           |           |           |           |           |                  |           |           |           |           |           |           |           |                  |           |           |           |           |           |           |           |                  |           |           | X         |           |           |           |           |
| 9            | X                |           |           |           |           |           |           | X         |                  |           |           |           |           |           | X         | X         |                  |           |           |           |           |           | X         | X         |                  |           |           |           |           |           |           |           |                  |           | X         |           |           |           |           |           |
| 10           |                  |           |           |           |           |           |           |           |                  |           |           |           |           |           |           |           |                  |           |           |           |           |           |           |           |                  |           |           |           |           |           |           |           |                  |           |           | X         |           |           |           |           |
| 11           |                  |           |           |           |           |           |           |           |                  |           |           |           |           |           |           |           |                  |           |           |           |           |           |           |           |                  |           |           |           |           |           |           |           |                  |           |           | X         |           |           |           |           |
| 12           |                  |           |           |           |           |           |           |           |                  |           |           |           |           |           |           |           |                  |           |           |           |           |           |           |           |                  |           |           |           |           |           |           |           |                  |           |           | X         |           |           |           |           |
| 13           | X                |           |           |           |           |           |           | X         |                  |           |           |           |           |           |           |           |                  |           |           |           |           |           |           |           |                  |           |           |           |           |           |           |           |                  |           |           | X         |           |           |           |           |
| 14           |                  |           |           |           |           |           |           |           |                  |           |           |           |           |           |           |           |                  |           |           |           |           |           |           |           |                  |           |           |           |           |           |           |           |                  |           |           | X         |           |           |           |           |
| 15           |                  |           |           |           |           |           |           |           |                  |           |           |           |           |           |           |           |                  |           |           |           |           |           |           |           |                  |           |           |           |           |           |           |           |                  |           |           | X         |           |           |           |           |
| 16           |                  | X         |           |           |           |           |           |           |                  |           |           |           |           |           |           |           |                  |           |           |           |           |           |           |           |                  |           |           |           |           |           |           |           |                  |           |           | X         |           |           |           |           |
| 17           |                  | X         |           |           |           |           |           | X         |                  |           |           |           |           |           | X         |           |                  |           |           |           |           |           |           |           |                  |           |           |           |           |           |           |           |                  |           |           | X         |           |           |           |           |
| 18           |                  |           |           |           |           |           |           |           |                  |           |           |           |           |           |           |           |                  |           |           |           |           |           |           |           |                  |           |           |           |           |           |           |           |                  |           |           | X         |           |           |           |           |
| 19           |                  |           |           |           |           |           |           |           |                  |           |           |           |           |           |           |           |                  |           |           |           |           |           |           |           |                  |           |           |           |           |           |           |           |                  |           |           | X         |           |           |           |           |
| 20           |                  |           |           |           |           |           |           |           |                  |           |           |           |           |           |           |           |                  |           |           |           |           |           |           |           |                  |           |           |           |           |           |           |           |                  |           |           | X         |           |           |           |           |
| 21           |                  |           |           |           |           |           |           |           |                  |           |           |           |           |           |           |           |                  |           |           |           |           |           |           |           |                  |           |           |           |           |           |           |           |                  |           |           | X         |           |           |           |           |
| 22           |                  |           |           |           |           |           |           |           |                  |           |           |           |           |           |           |           |                  |           |           |           |           |           |           |           |                  |           |           |           |           |           |           |           |                  |           |           | X         |           |           |           |           |
| 23           |                  |           |           |           |           |           |           |           |                  |           |           |           |           |           |           |           |                  |           |           |           |           |           |           |           |                  |           |           |           |           |           |           |           |                  |           |           | X         |           |           |           |           |
| 24           |                  |           |           |           |           |           |           |           |                  |           |           |           |           |           |           |           |                  |           |           |           |           |           |           |           |                  |           |           |           |           |           |           |           |                  |           |           | X         |           |           |           |           |
| 25           |                  |           |           |           |           |           |           | X         |                  |           |           |           |           |           | X         |           |                  |           |           |           |           |           |           |           |                  |           |           |           |           |           |           |           |                  |           |           | X         |           |           |           |           |
| 26           |                  |           |           |           |           |           |           |           |                  |           |           |           |           |           |           |           |                  |           |           |           |           |           |           |           |                  |           |           |           |           |           |           |           |                  |           |           | X         |           |           |           |           |
| 27           |                  |           |           |           |           |           |           |           |                  |           |           |           |           |           |           |           |                  |           |           |           |           |           |           |           |                  |           |           |           |           |           |           |           |                  |           |           | X         |           |           |           |           |
| 28           |                  |           |           |           |           |           |           |           |                  |           |           |           |           |           |           |           |                  |           |           |           |           |           |           |           |                  |           |           |           |           |           |           |           |                  |           |           | X         |           |           |           |           |
| 29           |                  |           |           |           |           |           |           |           |                  |           |           |           |           |           |           |           |                  |           |           |           |           |           |           |           |                  |           |           |           |           |           |           |           |                  |           |           | X         |           |           |           |           |
| 30           |                  |           |           |           |           |           |           |           |                  |           |           |           |           |           |           |           |                  |           |           |           |           |           |           |           |                  |           |           |           |           |           |           |           |                  |           |           | X         |           |           |           |           |
| 31           |                  |           |           |           |           |           |           |           |                  |           |           |           |           |           |           |           |                  |           |           |           |           |           |           |           |                  |           |           |           |           |           |           |           |                  |           |           | X         |           |           |           |           |
| 32           |                  |           |           |           |           |           |           |           |                  |           |           |           |           |           |           |           |                  |           |           |           |           |           |           |           |                  |           |           |           |           |           |           |           |                  |           |           | X         |           |           |           |           |

| COUNT FOR 32 | RHYTHM 6 (SLOW ROCK) |               |               |               |               |               |               |               | RHYTHM 7 (BEAT) |               |               |               |               |               |               |               | RHYTHM 8 (SAMBA) |               |               |               |               |               |               |               | RHYTHM 9 (BOSSA NOVA) |               |               |               |               |               |               |               | RHYTHM 10 (CHA-CHA) |               |               |               |               |               |               |               |
|--------------|----------------------|---------------|---------------|---------------|---------------|---------------|---------------|---------------|-----------------|---------------|---------------|---------------|---------------|---------------|---------------|---------------|------------------|---------------|---------------|---------------|---------------|---------------|---------------|---------------|-----------------------|---------------|---------------|---------------|---------------|---------------|---------------|---------------|---------------------|---------------|---------------|---------------|---------------|---------------|---------------|---------------|
|              | O U T P U T 1        | O U T P U T 2 | O U T P U T 3 | O U T P U T 4 | O U T P U T 5 | O U T P U T 6 | O U T P U T 7 | O U T P U T 8 | O U T P U T 1   | O U T P U T 2 | O U T P U T 3 | O U T P U T 4 | O U T P U T 5 | O U T P U T 6 | O U T P U T 7 | O U T P U T 8 | O U T P U T 1    | O U T P U T 2 | O U T P U T 3 | O U T P U T 4 | O U T P U T 5 | O U T P U T 6 | O U T P U T 7 | O U T P U T 8 | O U T P U T 1         | O U T P U T 2 | O U T P U T 3 | O U T P U T 4 | O U T P U T 5 | O U T P U T 6 | O U T P U T 7 | O U T P U T 8 | O U T P U T 1       | O U T P U T 2 | O U T P U T 3 | O U T P U T 4 | O U T P U T 5 | O U T P U T 6 | O U T P U T 7 | O U T P U T 8 |
| 1            | X                    |               |               |               | X             | X             |               |               | X               |               |               |               |               |               |               |               | X                | X             | X             | X             | X             | X             | X             | X             | X                     | X             | X             | X             | X             | X             | X             | X             | X                   | X             | X             | X             |               |               |               |               |
| 2            |                      |               |               |               |               |               |               |               |                 |               |               |               |               |               |               |               |                  |               |               |               |               |               |               |               |                       |               |               |               |               |               |               |               |                     |               |               |               |               |               |               |               |
| 3            |                      |               |               |               | X             |               |               |               |                 |               |               |               |               | X             | X             |               |                  |               |               | X             | X             |               |               |               |                       |               |               |               |               |               |               |               |                     |               |               |               |               |               |               |               |
| 4            |                      |               |               |               |               | X             |               |               |                 |               |               |               |               |               |               |               |                  |               |               |               |               |               |               |               |                       |               |               |               |               |               |               |               |                     |               |               |               |               |               |               |               |
| 5            |                      |               |               |               | X             |               |               |               |                 |               |               |               |               |               |               |               |                  |               |               |               |               |               |               |               |                       |               |               |               |               |               |               |               |                     |               |               |               |               |               |               |               |
| 6            |                      |               |               |               | X             | X             |               |               |                 |               |               |               |               |               |               |               |                  |               |               |               |               |               |               |               |                       |               |               |               |               |               |               |               |                     |               |               |               |               |               |               |               |
| 7            |                      | X             |               |               | X             | X             |               |               |                 |               |               |               |               |               |               |               |                  |               |               |               |               |               |               |               |                       |               |               |               |               |               |               |               |                     |               |               |               |               |               |               |               |
| 8            |                      |               |               |               |               |               |               |               |                 |               |               |               |               |               |               |               |                  |               |               |               |               |               |               |               |                       |               |               |               |               |               |               |               |                     |               |               |               |               |               |               |               |
| 9            |                      |               |               |               | X             |               |               |               |                 |               |               |               |               |               |               |               |                  |               |               |               |               |               |               |               |                       |               |               |               |               |               |               |               |                     |               |               |               |               |               |               |               |
| 10           |                      |               |               |               |               |               |               |               |                 |               |               |               |               |               |               |               |                  |               |               |               |               |               |               |               |                       |               |               |               |               |               |               |               |                     |               |               |               |               |               |               |               |
| 11           | X                    |               |               |               | X             |               |               |               |                 |               |               |               |               |               |               |               |                  |               |               |               |               |               |               |               |                       |               |               |               |               |               |               |               |                     |               |               |               |               |               |               |               |
| 12           |                      |               |               |               |               |               |               |               |                 |               |               |               |               |               |               |               |                  |               |               |               |               |               |               |               |                       |               |               |               |               |               |               |               |                     |               |               |               |               |               |               |               |
| 13           | X                    |               |               |               | X             | X             |               |               |                 |               |               |               |               |               |               |               |                  |               |               |               |               |               |               |               |                       |               |               |               |               |               |               |               |                     |               |               |               |               |               |               |               |
| 14           |                      |               |               |               |               |               |               |               |                 |               |               |               |               |               |               |               |                  |               |               |               |               |               |               |               |                       |               |               |               |               |               |               |               |                     |               |               |               |               |               |               |               |
| 15           |                      |               |               |               | X             |               |               |               |                 |               |               |               |               |               |               |               |                  |               |               |               |               |               |               |               |                       |               |               |               |               |               |               |               |                     |               |               |               |               |               |               |               |
| 16           |                      |               |               |               |               |               |               |               |                 |               |               |               |               |               |               |               |                  |               |               |               |               |               |               |               |                       |               |               |               |               |               |               |               |                     |               |               |               |               |               |               |               |
| 17           |                      |               |               |               | X             |               |               |               |                 |               |               |               |               |               |               |               |                  |               |               |               |               |               |               |               |                       |               |               |               |               |               |               |               |                     |               |               |               |               |               |               |               |
| 18           |                      |               |               |               |               |               |               |               |                 |               |               |               |               |               |               |               |                  |               |               |               |               |               |               |               |                       |               |               |               |               |               |               |               |                     |               |               |               |               |               |               |               |
| 19           | X                    |               |               |               | X             | X             |               |               |                 |               |               |               |               |               |               |               |                  |               |               |               |               |               |               |               |                       |               |               |               |               |               |               |               |                     |               |               |               |               |               |               |               |
| 20           |                      |               |               |               |               |               |               |               |                 |               |               |               |               |               |               |               |                  |               |               |               |               |               |               |               |                       |               |               |               |               |               |               |               |                     |               |               |               |               |               |               |               |
| 21           |                      |               |               |               | X             |               |               |               |                 |               |               |               |               |               |               |               |                  |               |               |               |               |               |               |               |                       |               |               |               |               |               |               |               |                     |               |               |               |               |               |               |               |
| 22           |                      |               |               |               |               |               |               |               |                 |               |               |               |               |               |               |               |                  |               |               |               |               |               |               |               |                       |               |               |               |               |               |               |               |                     |               |               |               |               |               |               |               |
| 23           | X                    |               |               |               | X             |               |               |               |                 |               |               |               |               |               |               |               |                  |               |               |               |               |               |               |               |                       |               |               |               |               |               |               |               |                     |               |               |               |               |               |               |               |
| 24           |                      |               |               |               |               |               |               |               |                 |               |               |               |               |               |               |               |                  |               |               |               |               |               |               |               |                       |               |               |               |               |               |               |               |                     |               |               |               |               |               |               |               |
| 25           |                      |               |               |               |               |               |               |               |                 |               |               |               |               |               |               |               |                  |               |               |               |               |               |               |               |                       |               |               |               |               |               |               |               |                     |               |               |               |               |               |               |               |
| 26           |                      |               |               |               |               |               |               |               |                 |               |               |               |               |               |               |               |                  |               |               |               |               |               |               |               |                       |               |               |               |               |               |               |               |                     |               |               |               |               |               |               |               |
| 27           |                      |               |               |               |               |               |               |               |                 |               |               |               |               |               |               |               |                  |               |               |               |               |               |               |               |                       |               |               |               |               |               |               |               |                     |               |               |               |               |               |               |               |
| 28           |                      |               |               |               |               |               |               |               |                 |               |               |               |               |               |               |               |                  |               |               |               |               |               |               |               |                       |               |               |               |               |               |               |               |                     |               |               |               |               |               |               |               |
| 29           |                      |               |               |               |               |               |               |               |                 |               |               |               |               |               |               |               |                  |               |               |               |               |               |               |               |                       |               |               |               |               |               |               |               |                     |               |               |               |               |               |               |               |
| 30           |                      |               |               |               |               |               |               |               |                 |               |               |               |               |               |               |               |                  |               |               |               |               |               |               |               |                       |               |               |               |               |               |               |               |                     |               |               |               |               |               |               |               |
| 31           |                      |               |               |               |               |               |               |               |                 |               |               |               |               |               |               |               |                  |               |               |               |               |               |               |               |                       |               |               |               |               |               |               |               |                     |               |               |               |               |               |               |               |
| 32           |                      |               |               |               |               |               |               |               |                 |               |               |               |               |               |               |               |                  |               |               |               |               |               |               |               |                       |               |               |               |               |               |               |               |                     |               |               |               |               |               |               |               |

| COUNT FOR 32 | RHYTHM 11 (RUMBA) |               |               |               |               |               |               |               | RHYTHM 12 (BEGUINE) |               |               |               |               |               |               |               | RHYTHM 13 (BAJON) |               |               |               |               |               |               |               | RHYTHM 14 (FOX TROT) |               |               |               |               |               |               |               | RHYTHM 15 (SHUFFLE) |               |               |               |               |               |               |               |
|--------------|-------------------|---------------|---------------|---------------|---------------|---------------|---------------|---------------|---------------------|---------------|---------------|---------------|---------------|---------------|---------------|---------------|-------------------|---------------|---------------|---------------|---------------|---------------|---------------|---------------|----------------------|---------------|---------------|---------------|---------------|---------------|---------------|---------------|---------------------|---------------|---------------|---------------|---------------|---------------|---------------|---------------|
|              | O U T P U T 1     | O U T P U T 2 | O U T P U T 3 | O U T P U T 4 | O U T P U T 5 | O U T P U T 6 | O U T P U T 7 | O U T P U T 8 | O U T P U T 1       | O U T P U T 2 | O U T P U T 3 | O U T P U T 4 | O U T P U T 5 | O U T P U T 6 | O U T P U T 7 | O U T P U T 8 | O U T P U T 1     | O U T P U T 2 | O U T P U T 3 | O U T P U T 4 | O U T P U T 5 | O U T P U T 6 | O U T P U T 7 | O U T P U T 8 | O U T P U T 1        | O U T P U T 2 | O U T P U T 3 | O U T P U T 4 | O U T P U T 5 | O U T P U T 6 | O U T P U T 7 | O U T P U T 8 | O U T P U T 1       | O U T P U T 2 | O U T P U T 3 | O U T P U T 4 | O U T P U T 5 | O U T P U T 6 | O U T P U T 7 | O U T P U T 8 |
| 1            | X                 | X             |               |               |               |               |               | X             | X                   | X             |               |               |               |               |               |               |                   |               |               |               |               |               |               |               |                      |               |               |               |               |               |               |               |                     |               |               |               |               |               |               |               |
| 2            |                   |               |               |               |               |               |               |               |                     |               |               |               |               |               |               |               |                   |               |               |               |               |               |               |               |                      |               |               |               |               |               |               |               |                     |               |               |               |               |               |               |               |
| 3            |                   |               |               |               |               |               |               |               |                     |               |               |               |               |               |               |               |                   |               |               |               |               |               |               |               |                      |               |               |               |               |               |               |               |                     |               |               |               |               |               |               |               |
| 4            |                   |               |               |               |               | X             |               |               |                     |               |               |               |               |               |               |               |                   |               |               |               |               |               |               |               |                      |               |               |               |               |               |               |               |                     |               |               |               |               |               |               |               |
| 5            |                   |               |               |               | X             |               |               |               |                     |               |               |               |               |               |               |               |                   |               |               |               |               |               |               |               |                      |               |               |               |               |               |               |               |                     |               |               |               |               |               |               |               |
| 6            |                   |               |               |               |               |               |               |               |                     |               |               |               |               |               |               |               |                   |               |               |               |               |               |               |               |                      |               |               |               |               |               |               |               |                     |               |               |               |               |               |               |               |
| 7            | X                 |               |               |               | X             | X             |               |               |                     |               |               |               |               |               |               |               |                   |               |               |               |               |               |               |               |                      |               |               |               |               |               |               |               |                     |               |               |               |               |               |               |               |
| 8            |                   |               |               |               |               |               |               |               |                     |               |               |               |               |               |               |               |                   |               |               |               |               |               |               |               |                      |               |               |               |               |               |               |               |                     |               |               |               |               |               |               |               |
| 9            |                   |               |               |               | X             |               |               |               |                     |               |               |               |               |               |               |               |                   |               |               |               |               |               |               |               |                      |               |               |               |               |               |               |               |                     |               |               |               |               |               |               |               |
| 10           |                   |               |               |               |               |               |               |               |                     |               |               |               |               |               |               |               |                   |               |               |               |               |               |               |               |                      |               |               |               |               |               |               |               |                     |               |               |               |               |               |               |               |
| 11           |                   |               |               |               | X             |               |               |               |                     |               |               |               |               |               |               |               |                   |               |               |               |               |               |               |               |                      |               |               |               |               |               |               |               |                     |               |               |               |               |               |               |               |
| 12           |                   |               |               |               |               |               |               |               |                     |               |               |               |               |               |               |               |                   |               |               |               |               |               |               |               |                      |               |               |               |               |               |               |               |                     |               |               |               |               |               |               |               |
| 13           | X                 |               |               |               |               |               |               |               |                     |               |               |               |               |               |               |               |                   |               |               |               |               |               |               |               |                      |               |               |               |               |               |               |               |                     |               |               |               |               |               |               |               |
| 14           |                   |               |               |               |               |               |               |               |                     |               |               |               |               |               |               |               |                   |               |               |               |               |               |               |               |                      |               |               |               |               |               |               |               |                     |               |               |               |               |               |               |               |
| 15           |                   |               |               |               | X             |               |               |               |                     |               |               |               |               |               |               |               |                   |               |               |               |               |               |               |               |                      |               |               |               |               |               |               |               |                     |               |               |               |               |               |               |               |
| 16           |                   |               |               |               |               |               |               |               |                     |               |               |               |               |               |               |               |                   |               |               |               |               |               |               |               |                      |               |               |               |               |               |               |               |                     |               |               |               |               |               |               |               |
| 17           | X                 |               |               |               |               |               |               |               |                     |               |               |               |               |               |               |               |                   |               |               |               |               |               |               |               |                      |               |               |               |               |               |               |               |                     |               |               |               |               |               |               |               |
| 18           |                   |               |               |               |               |               |               |               |                     |               |               |               |               |               |               |               |                   |               |               |               |               |               |               |               |                      |               |               |               |               |               |               |               |                     |               |               |               |               |               |               |               |
| 19           |                   |               |               |               | X             |               |               |               |                     |               |               |               |               |               |               |               |                   |               |               |               |               |               |               |               |                      |               |               |               |               |               |               |               |                     |               |               |               |               |               |               |               |
| 20           |                   |               |               |               |               |               |               |               |                     |               |               |               |               |               |               |               |                   |               |               |               |               |               |               |               |                      |               |               |               |               |               |               |               |                     |               |               |               |               |               |               |               |
| 21           | X                 |               |               |               | X             |               |               |               |                     |               |               |               |               |               |               |               |                   |               |               |               |               |               |               |               |                      |               |               |               |               |               |               |               |                     |               |               |               |               |               |               |               |
| 22           |                   |               |               |               |               |               |               |               |                     |               |               |               |               |               |               |               |                   |               |               |               |               |               |               |               |                      |               |               |               |               |               |               |               |                     |               |               |               |               |               |               |               |
| 23           | X                 |               |               |               |               |               |               |               |                     |               |               |               |               |               |               |               |                   |               |               |               |               |               |               |               |                      |               |               |               |               |               |               |               |                     |               |               |               |               |               |               |               |
| 24           |                   |               |               |               |               |               |               |               |                     |               |               |               |               |               |               |               |                   |               |               |               |               |               |               |               |                      |               |               |               |               |               |               |               |                     |               |               |               |               |               |               |               |
| 25           | X                 |               |               |               | X             | X             | X             |               |                     |               |               |               |               |               |               |               |                   |               |               |               |               |               |               |               |                      |               |               |               |               |               |               |               |                     |               |               |               |               |               |               |               |
| 26           |                   |               |               |               |               |               |               |               |                     |               |               |               |               |               |               |               |                   |               |               |               |               |               |               |               |                      |               |               |               |               |               |               |               |                     |               |               |               |               |               |               |               |
| 27           |                   |               |               |               | X             |               |               |               |                     |               |               |               |               |               |               |               |                   |               |               |               |               |               |               |               |                      |               |               |               |               |               |               |               |                     |               |               |               |               |               |               |               |
| 28           |                   |               |               |               |               |               |               |               |                     |               |               |               |               |               |               |               |                   |               |               |               |               |               |               |               |                      |               |               |               |               |               |               |               |                     |               |               |               |               |               |               |               |
| 29           | X                 |               |               |               | X             |               |               |               |                     |               |               |               |               |               |               |               |                   |               |               |               |               |               |               |               |                      |               |               |               |               |               |               |               |                     |               |               |               |               |               |               |               |
| 30           |                   |               |               |               |               |               |               |               |                     |               |               |               |               |               |               |               |                   |               |               |               |               |               |               |               |                      |               |               |               |               |               |               |               |                     |               |               |               |               |               |               |               |
| 31           |                   |               |               |               | X             | X             |               |               |                     |               |               |               |               |               |               |               |                   |               |               |               |               |               |               |               |                      |               |               |               |               |               |               |               |                     |               |               |               |               |               |               |               |
| 32           |                   |               |               |               |               |               |               |               |                     |               |               |               |               |               |               |               |                   |               |               |               |               |               |               |               |                      |               |               |               |               |               |               |               |                     |               |               |               |               |               |               |               |