



Product Specification

M255UW02 V0

AU OPTRONICS CORPORATION

(V) Preliminary Specification

() Final Specification

Module	25.5" WUXGA Color TFT-LCD
Model Name	M255UW02 V0

Customer	Date
_____	_____
Approved by	
_____	_____
Note: This Specification is subject to change without notice.	

Checked & Approved by	Date
<i>JW Lin</i>	2007/9/11
Prepared by	
<i>Hannie Yeh</i>	2007/9/11
Desktop Display Business Group / AU Optronics corporation	



Contents

1. Handling Precautions	5
2. General Description	6
2.1 Display Characteristics	6
2.2 Optical Characteristics	6
3. Functional Block Diagram	12
4. Absolute Maximum Ratings	13
4.1 TFT LCD Module	11
4.2 Backlight Unit	11
4.3 Absolute Ratings of Environment	11
5. Electrical characteristics	13
5.1 TFT LCD Module	14
5.1.1 Power Specification	12
5.1.2 Signal Electrical Characteristic	13
5.2 Backlight Unit	14
5.3 Inverter Electrical Characteristic	15
6. Signal Characteristic	14
6.1 Pixel Format Image	14
6.2 The Input Data Format	14
6.3 Signal Description	16
6.4 Interface Timing	14
6.4.1 Timing Characteristics	18
6.4.2 Timing Diagram	19
6.5 Power ON/OFF Sequence	14
7. Connector & Pin Assignment	14
7.1 TFT LCD Module	14
7.1.1 Connector	21
7.1.2 Pin Assignment	21
7.2 Backlight Unit	14
7.2.1 Signal for Inverter	23
7.2.2 Signal for Lamp Connector	24
8. Reliability Test	14
9. Shipping Label	14
10. Mechanical Characteristics	14



Product Specification

M255UW02 V0

AU OPTRONICS CORPORATION

Record of Revision

Version and Date	Page	Old description	New Description				Remark
0.1 2007/7/12	All	First Edition for Customer	All				
0.2 2007/9/11	6	N/A	SPD technology full name and Motion Picture Response Time 8ms (Typ.)				Add
	6	Power Consumption = 75W (Typ. with Invertor)	Power Consumption = 68W (Typ., SPD off) / 70W (Typ., SPD on)				Modified
	6	Weight = 3450 grams (Max.)	Weight = 4200 grams (Typ.)				Modified
	6	Surface treatment = Hard-coating (3H), Anit-Glare type	Surface treatment = Hard-coating (2H), Glare type				Modified
	7	Viewing Angle Horizontal (Right)+ (Left) CR = 10: 150° (min.), 160° (Typ.)	Viewing Angle Horizontal (Right)+ (Left) CR = 10: 160° (min.), 170° (Typ.)				Modified
	7	N/A	MPRT (SPD on) 8ms (Typ.); 15ms (Max.)				Add
	7	Color / Chromaticity Coordinates (CIE 1931) is TBD	Conditions	Min.	Typ.	Max.	Modified
			Red x	0.626	0.656	0.686	
			Red y	0.302	0.332	0.362	
			Green x	0.185	0.215	0.245	
			Green y	0.647	0.677	0.707	
			Blue x	0.117	0.147	0.177	
			Blue y	0.030	0.070	0.100	
			White x	0.283	0.313	0.343	
			White y	0.299	0.329	0.359	
	11	N/A	Define SPD measurement.				Add
	12	N/A	DC power input inverter +24V				Add
	14	N/A	IDD input current and PDD VDD power when SPD is on.				Add
	14	IDD input current and PDD VDD power are TBD.	IDD input current = 1.0 mA (Typ., SPD off)/1.4mA (Max., SPD off), 1.4mA (Typ., SPD on)/1.8mA (Max., SPD on); PDD VDD power = 5.0W (Typ., SPD off)/7.0W (Max., SPD off), 7.9W (Typ., SPD on)/9.0W (Max., SPD on)				Modified
	16	N/A	CCFL Operation Current (ICFL) condition $V_{BR}=1.65V$				Add
	17	I_{DDB} input current and P_B input power are TBD.	I_{DDB} input current =2.6A (Typ.)/3.0A (Max.); P_B input power = 62.4W (Typ.) /72.0W (Max.)				Modified
	17	$V_{ON/OFF}$ Backlight on/off control condition: Lamp ON = High / Lamp OFF = Low	$V_{ON/OFF}$ Backlight on/off control condition: Enable/Disable the inverter.				Modified
	17	N/A					Add
	17	4. The life is determined as the time	4. The life is determined as the time at which				Modified



Product Specification

M255UW02 V0

AU OPTRONICS CORPORATION

		at which luminance of the lamp is 50% compared to that of initial value at the typical lamp current on condition of continuous operating at 25±2C 5. Electrical charecteristics are determined after the unit has been 'ON' and stable for approximately 30min at 25±2C.	luminance of the lamp is 50% compared to that of initial value at the typical lamp current on condition of continuous operating at 25±2°C . 5. Electrical charecteristics are determined after the unit has been 'ON' and stable for approximately 30min at 25±2°C .	
	20	Vertical Section Period = 1212 th (min.), Blanking = 12 th (min.); Horizontal Section Blanking = 80 tclk (min.); Frame Rate Frequency min/Max is TBD.	Vertical Section Period = 1210 th (min.), Blanking = 10 th (min.) ; Horizontal Section Blanking = 90 tclk (min.); Frame Rate Frequency = 47Hz (min.), 65Hz (Max.)	Modified
	20	N/A	Note 1: Typical value refer to VESA STANDARD Note 3: When panel is operated at SPD mode, the timing is recommended at typical value.	Add
	26	High Temperature Operation (HTO) required condition: 50%RH	N/A	Delete
	26	Vibration Test (Non-operation) required condition: Wave: Half-sine, Frequency: 10-200Hz.	Vibration Test (Non-operation) required condition: Wave: Sine, Frequency: 10-300Hz.	Modified



Product Specification

M255UW02 V0

AU OPTRONICS CORPORATION

1. Handling Precautions

- 1) Since front polarizer is easily damaged, pay attention not to scratch it.
- 2) Be sure to turn off power supply when inserting or disconnecting from input connector.
- 3) Wipe off water drop immediately. Long contact with water may cause discoloration or spots.
- 4) When the panel surface is soiled, wipe it with absorbent cotton or other soft cloth.
- 5) Since the panel is made of glass, it may break or crack if dropped or bumped on hard surface.
- 6) Since CMOS LSI is used in this module, take care of static electricity and insure human earth when handling.
- 7) Do not open or modify the Module Assembly.
- 8) Do not press the reflector sheet at the back of the module to any directions.
- 9) In case if a Module has to be put back into the packing container slot after once it was taken out from the container, do not press the center of the CCFL reflector edge. Instead, press at the far ends of the CCFL Reflector edge softly. Otherwise the TFT Module may be damaged.
- 10) At the insertion or removal of the Signal Interface Connector, be sure not to rotate nor tilt the Interface Connector of the TFT Module.
- 11) After installation of the TFT Module into an enclosure, do not twist nor bend the TFT Module even momentary. At designing the enclosure, it should be taken into consideration that no bending/twisting forces are applied to the TFT Module from outside. Otherwise the TFT Module may be damaged.
- 12) Cold cathode fluorescent lamp in LCD contains a small amount of mercury. Please follow local ordinances or regulations for disposal.
- 13) Small amount of materials having no flammability grade is used in the LCD module. The LCD module should be supplied by power complied with requirements of Limited Power Source (IEC60950 or UL1950), or be applied exemption.
- 14) The LCD module is designed so that the CCFL in it is supplied by Limited Current Circuit (IEC60950 or UL1950). Do not connect the CCFL in Hazardous Voltage Circuit.



Product Specification

M255UW02 V0

AU OPTRONICS CORPORATION

2. General Description

This specification applies to the 25.5 inch-wide Color TFT-LCD Module M255UW02

The display supports the WUXGA (1920(H) x 1200(V)) screen format and 16.7M colors (RGB 6 bits + Hi-FRC data) and using Simulated Pulsed Driving (SPD) technology with fast response time to reduce motion blur.

All input signals are 2 channel LVDS interface compatible.

This module contains an inverter card for backlight.

2.1 Display Characteristics

The following items are characteristics summary on the table under 25 °C condition:

Items	Unit	Specifications
Screen Diagonal	[mm]	648.7 (25.5")
Active Area	[mm]	550.1 (H) x 343.8 (V)
Pixels H x V		1920 x 3 (RGB) x 1200
Pixel Pitch	[mm]	0.287 x 0.287
Pixel Arrangement		R.G.B. Vertical Stripe
Display Mode		TN Mode, Normally White
White Luminance	[cd/m ²]	450 cd/m ² @ 6.0mA (Typ)
Contrast Ratio		1000:1 (Typ),
Optical Response Time	[msec]	5ms (Typ. on/off)
Moving Picture Response Time	msec	8ms (Typ. SPD function on)
Nominal Input Voltage VDD	[Volt]	+5.0 V
Power Consumption (VDD line + CCFL line)	[Watt]	68W (Typ., SPD off) / 70W (Typ., SPD on)
Weight	[Grams]	4200 (Typ.)
Physical Size (H x V x D)	[mm]	582.0 (W) x 375.6 (H) x 41.5 (D) (Typ.)
Electrical Interface		Dual Channel LVDS
Support Colors		16.7M colors (6 bits + Hi-FRC)
Temperature Range		
Operating	[°C]	0 to +50
Storage (Shipping)	[°C]	-20 to +60
Surface Treatment		Hard-coating (2H), Glare type
RoHS Compliance		RoHS Compliance



Product Specification

M255UW02 V0

AU OPTRONICS CORPORATION

2.2 Optical Characteristics

The optical characteristics are measured under stable conditions at 25°C (Room Temperature):

Item	Unit	Conditions	Min.	Typ.	Max.	Note
Viewing Angle	[degree]	Horizontal (Right)+ (Left) CR = 10	160	170	-	Note 1
		Vertical (Up) + (Down) CR = 10	150	160	-	
Luminance Uniformity	[%]	9 Points	80	85	-	Note 2, 3
Optical Response Time	[msec]	Rising	-	3.4	5.7	Note 4, 6
		Falling	-	1.6	2.3	
		Rising + Falling	-	5	8	
		MPRT (SPD on)		8	15	Note 8
Color / Chromaticity Coordinates (CIE 1931)		Red x	0.626	0.656	0.686	
		Red y	0.302	0.332	0.362	
		Green x	0.185	0.215	0.245	
		Green y	0.647	0.677	0.707	
		Blue x	0.117	0.147	0.177	
		Blue y	0.030	0.070	0.100	
		White x	0.283	0.313	0.343	
White y	0.299	0.329	0.359			
White Luminance (At CCFL= 6.0mA)	[cd/m ²]		300	450	-	Note 4
Contrast Ratio		Normal Direction	600	1000	-	Note 4
Cross Talk (At 60Hz)	[%]		-	-	1.5	Note 5
Flicker	[dB]		-	-	-20	Note 7

Optical Equipment Pattern Generator, Power Supply, Digital Voltmeter, Luminance meter (PR 880, BM-5A, BM 7, CS-1000 & EZContrast*)

Aperture 1° with 100cm VD or 2° with 50cm viewing distance

Test Point Center (VESA point 9)

Environment < 1 lux

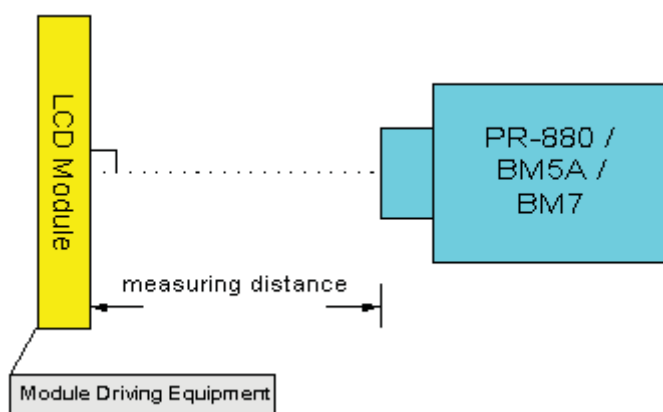

*EZContrast is different measurement tool with very close viewing distance.



Product Specification

M255UW02 V0

AU OPTRONICS CORPORATION

Note 1: Definition of viewing angle: measured by ELDIM (EZContrast 88)

Viewing angle is the measurement of contrast ratio ≥ 10 , at the screen center, over a 180° horizontal and 180° vertical range (off-normal viewing angles). The 180° viewing angle range is broken down as follows; 90° (θ) horizontal left and right and 90° (Φ) vertical, high (up) and low (down). The measurement direction is typically perpendicular to the display surface with the screen rotated about its center to develop the desired measurement viewing angle.

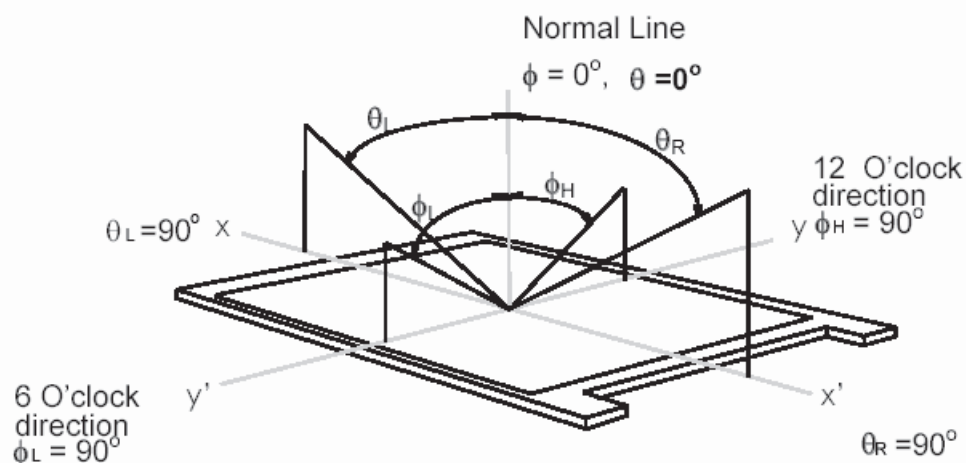

Note 2: 9 points position

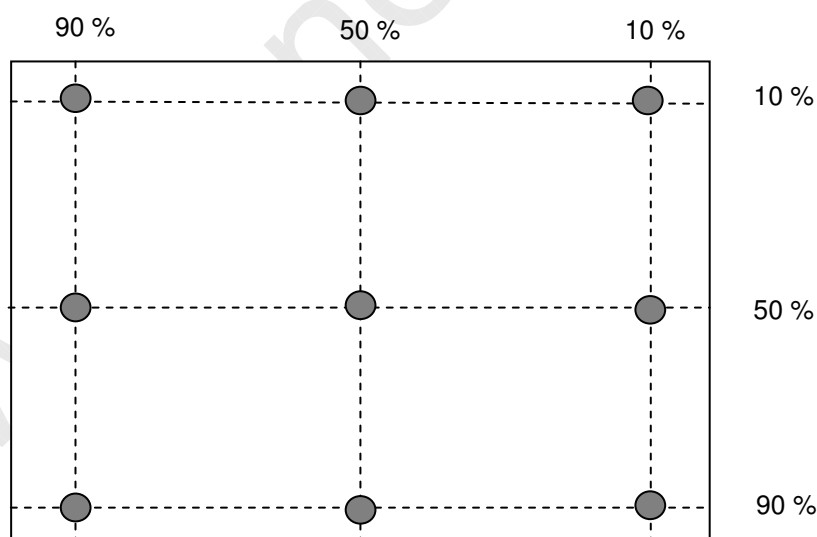

Note 3: The luminance uniformity of 9 points is defined by dividing the maximum luminance values by the minimum test point luminance

$$\delta_{w9} = \frac{\text{Minimum Luminance of 9 points}}{\text{Maximum Luminance of 9 points}}$$



Product Specification

M255UW02 V0

AU OPTRONICS CORPORATION

Note 4: Measurement method

The LCD module should be stabilized at given temperature for 30 minutes to avoid abrupt temperature change during measuring. In order to stabilize the luminance, the measurement should be executed after lighting Backlight for 30 minutes in a stable, windless and dark room.

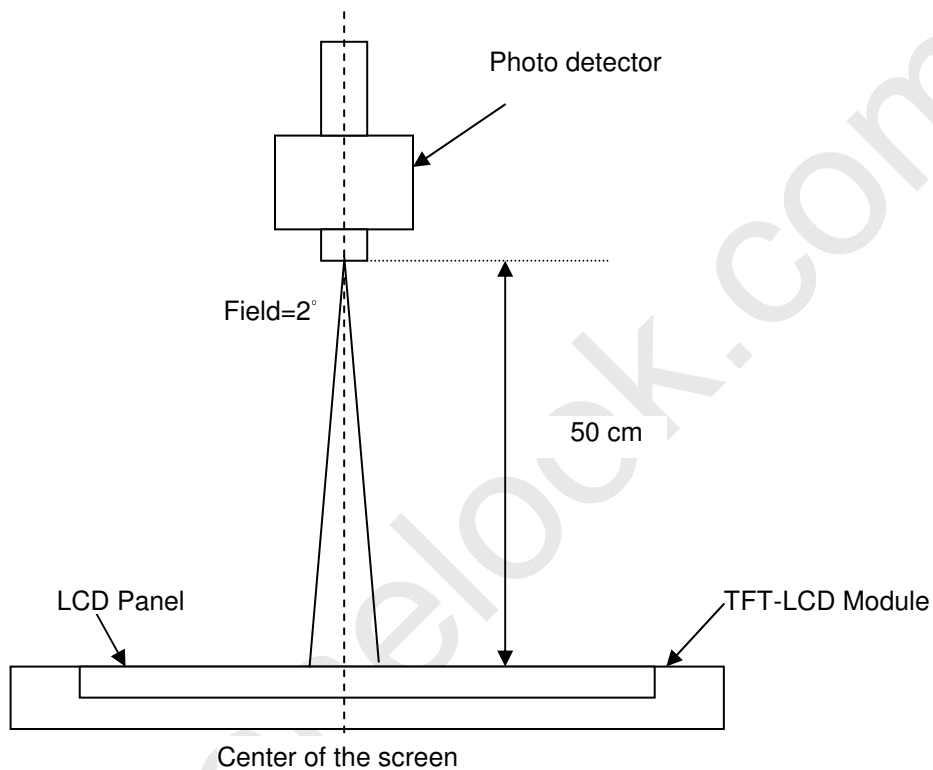

Note 5: Definition of Cross Talk (CT)

$$CT = |Y_B - Y_A| / Y_A \times 100 (\%)$$

Where

Y_A = Luminance of measured location without gray level 0 pattern (cd/m²)

Y_B = Luminance of measured location with gray level 0 pattern (cd/m²)

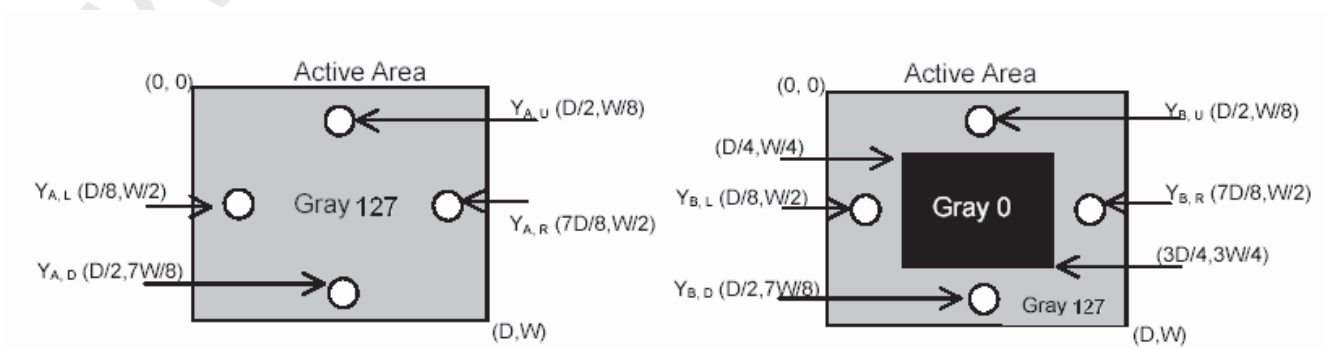



Product Specification

M255UW02 V0

AU OPTRONICS CORPORATION

Note 6: Definition of response time:

The output signals of photo detector are measured when the input signals are changed from “Full Black” to “Full White” (rising time), and from “Full White” to “Full Black” (falling time), respectively. The response time is interval between the 10% and 90% of amplitudes. Please refer to the figure as below.

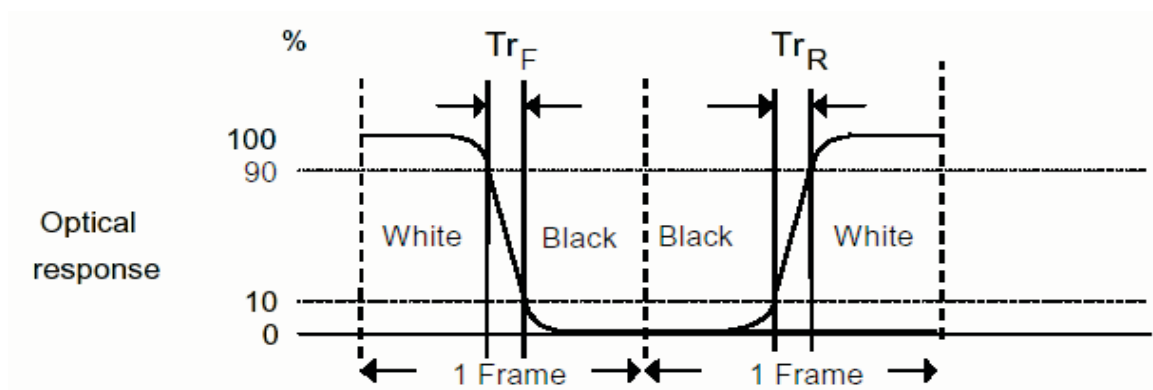

Note 7: Subchecker Pattern

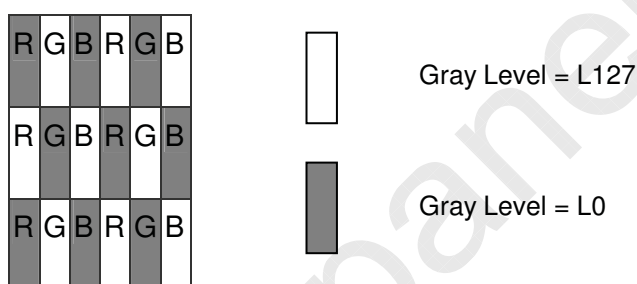

Method: Record dBV & DC value with (WESTAR)TRD-100

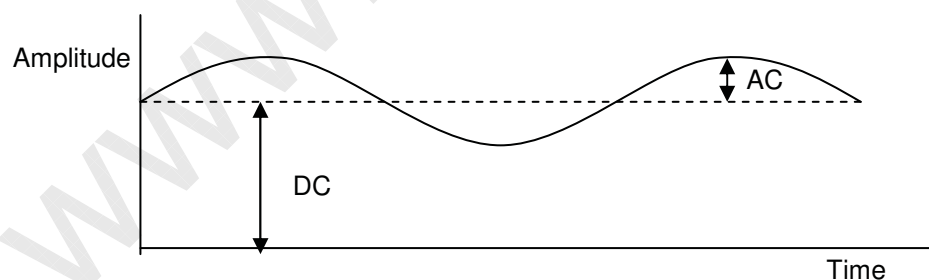

$$\text{Flicker (dB)} = 20 \log \frac{\text{AC Level(at 30 Hz)}}{\text{DC Level}}$$



Product Specification

M255UW02 V0

AU OPTRONICS CORPORATION

Note 8: SPD Measurement is defined as below (measured by Otsuka MPRT-1000).

MPRT(Moving Picture Response Time) is the average value of BET measured from 72 combinations of different gray levels.

We divide the measurement base on each 32 gray level. Because the brightness between L0 & L32 is so slight and it will cause noise to influence the outcome, we set L42 instead of L32. We can get 72 combination data as the table below.

		Start Gray								
		L0	L42	L64	L96	L128	L160	L192	L224	L255
Background (End Gray)	L0		BET9	BET17	BET25	BET33	BET41	BET49	BET57	BET65
	L42	BET1		BET18	BET26	BET34	BET42	BET50	BET58	BET66
	L64	BET2	BET10		BET27	BET35	BET43	BET51	BET59	BET67
	L96	BET3	BET11	BET19		BET36	BET44	BET52	BET60	BET68
	L128	BET4	BET12	BET20	BET28		BET45	BET53	BET61	BET69
	L160	BET5	BET13	BET21	BET29	BET37		BET54	BET62	BET70
	L192	BET6	BET14	BET22	BET30	BET38	BET46		BET63	BET71
	L224	BET7	BET15	BET23	BET31	BET39	BET47	BET55		BET72
	L255	BET8	BET16	BET24	BET32	BET40	BET48	BET56	BET64	

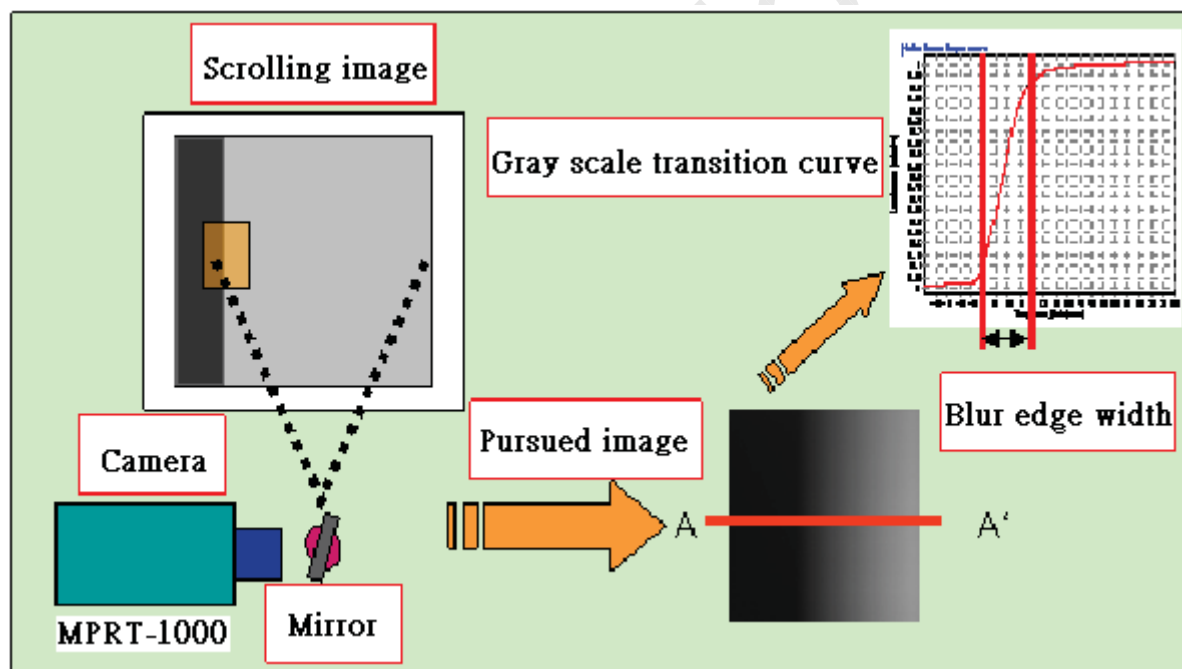

$$MPRT \text{ (seconds)} = \frac{BET_1 + BET_2 + \dots + BET_{72}}{72}$$

$$BET = BEW \times \frac{1}{\text{scrolling speed} \times \text{frame rate}}$$

BEW: Blur Edge Width (LCD pixel). The width is defined to be used for the values 10%~90% of luminance.

Note: scrolling speed=8ppf (LCD pixel/frame rate) ; frame rate=60Hz



Product Specification

M255UW02 V0

AU OPTRONICS CORPORATION

3. Functional Block Diagram

The following diagram shows the functional block of the 25.5 inches wide Color TFT-LCD Module:

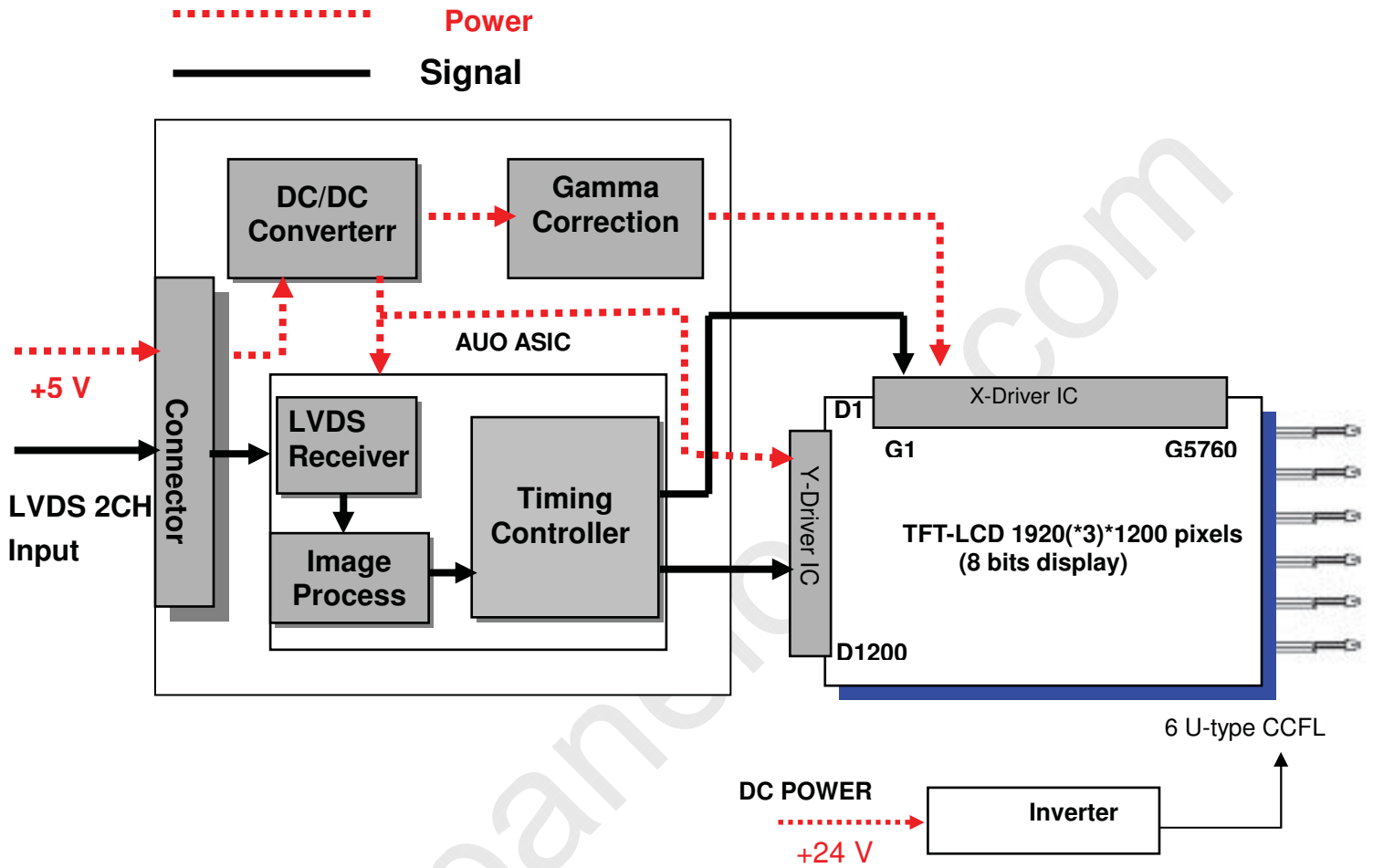

I/F PCB Interface:

JAE FI-X30SSL-HF or compatible

Inverter Interface:

JST S14B-PH-SM3-TB or compatible

Mating Type:

I/F PCB Interface:

FI-X30H(Unlocked Type) or FI-X30HL(Locked Type)

Inverter Interface:

PHR-14



Product Specification

M255UW02 V0

AU OPTRONICS CORPORATION

4. Absolute Maximum Ratings

Absolutely maximum rating of the module is as following:

4.1 TFT LCD Module

Item	Symbol	Min	Max	Unit	Conditions
Logic/LCD Drive	VIN	4.5	5.5	[Volt]	Note 1,2

4.2 Backlight Unit

Item	Symbol	Min	Max	Unit	Conditions
CCFL Current	ICFL	5.5	6.5	[mA] rms	Note 1,2

4.3 Absolute Ratings of Environment

Item	Symbol	Min	Max	Unit	Conditions
Operating Humidity	HOP	5	95	[%RH]	Note 3
Operating Temperature	TOP	0	+50	[°C]	Note 3
Storage Temperature	TST	-20	+60	[°C]	Note 3
Storage Humidity	HST	5	95	[%RH]	Note 3

Note 1: With in $T_a = 25^\circ\text{C}$

Note 2: Permanent damage to the device may occur if exceed maximum values

Note 3: For quality performance, please refer to AUO IIS (Incoming Inspection Standard).

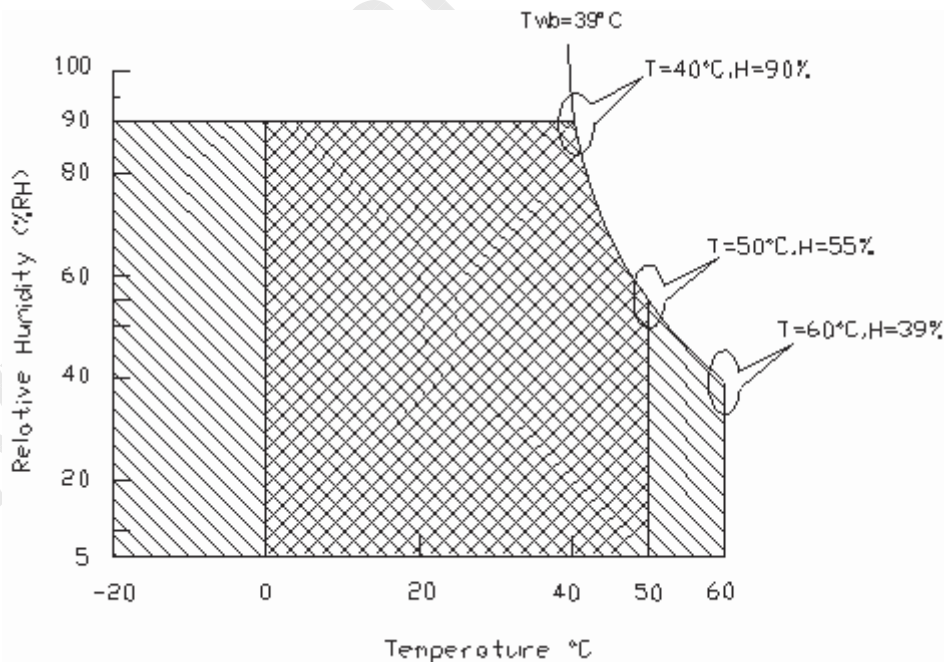

Operating Range



Storage Range

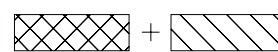



Product Specification

M255UW02 V0

AU OPTRONICS CORPORATION

5. Electrical characteristics

5.1 TFT LCD Module

5.1.1 Power Specification

Input power specifications are as follows:

Symble	Parameter	Min.	Typ.	Max.	Unit	Condition
VDD	Logic/LCD Drive Voltage	4.5	5.0	5.5	[Volt]	± 10%
IDD	Input Current	-	1.0	1.4	[A]	VDD= 5.0V, All Black Pattern At frame rate 60Hz, SPD off.
		-	1.4	1.8	[A]	VDD= 5.0V, All Black Pattern At frame rate 60Hz, SPD on.
PDD	VDD Power	-	5.0	7.0	[Watt]	VDD= 5.0V, All Black Pattern At frame rate 60Hz, SPD off.
		-	7.0	9.0	[Watt]	VDD= 5.0V, All Black Pattern At frame rate 60Hz, SPD on.
IRush	Inrush Current	-	-	3	[A]	Note

Note: Measurement conditions:

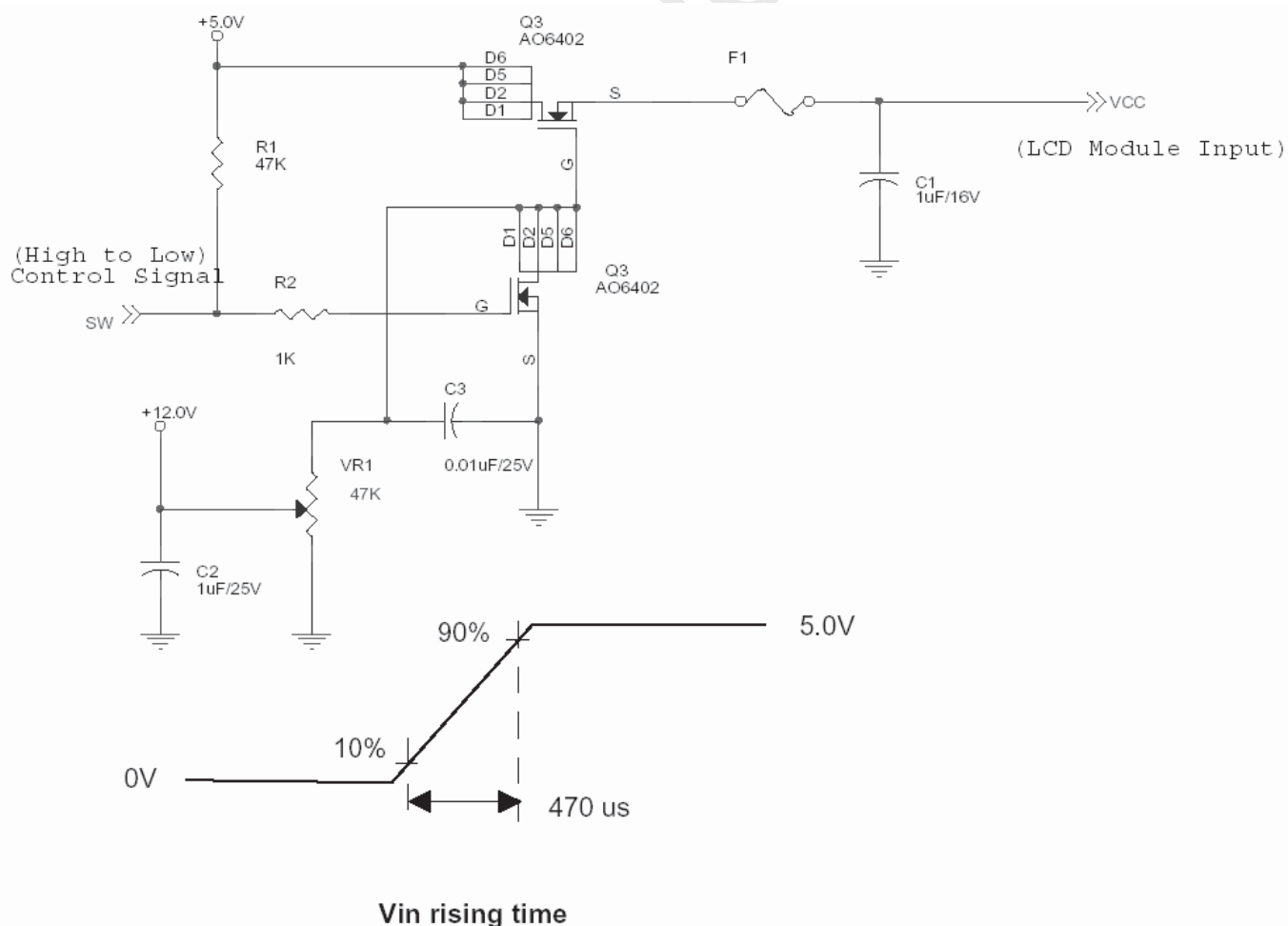



Product Specification

M255UW02 V0

AU OPTRONICS CORPORATION

5.1.2 Signal Electrical Characteristics

Input signals shall be low or Hi-Z state when V_{in} is off

It is recommended to refer the specifications of SN75LVDS82DGG (Texas Instruments) in detail.

Each signal characteristics are as follows;

Symbol	Parameter	Min	Typ	Max	Units	Condition
VTH	Differential Input High Threshold	-	+50	+100	[mV]	$V_{ICM} = 1.2V$, Note
VTL	Differential Input Low Threshold	-100	-50	-	[mV]	$V_{ICM} = 1.2V$, Note
VID	Input Differential Voltage	100	-	600	[mV]	Note
VICM	Differential Input Common Mode Voltage	+1.0	+1.2	+1.5	[V]	$V_{TH}-V_{TL} = 200mV$, Note

Note: LVDS Signal Waveform

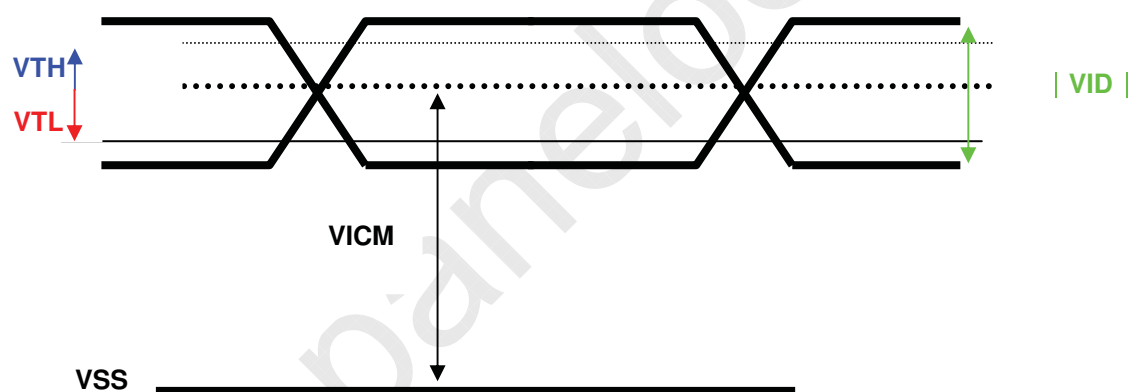



Product Specification

M255UW02 V0

AU OPTRONICS CORPORATION

5.2 Backlight Unit

Parameter guideline for CCFL Inverter is under stable conditions at 25°C (Room Temperature):

Parameter	Min.	Typ.	Max.	Unit	Condition
CCFL Operation Current (ICFL)	5.5	6.0	6.5	[mA] rms	Note 2 ; $V_{BR}=1.65V$
CCFL Frequency (FCFL)	40	60	80	[KHz]	Note 3,4
CCFL Ignition Voltage(V_{ICFL} , $T_a=0^{\circ}C$)	3600			[Volt] rms	
CCFL Ignition Voltage(V_{ICFL} , $T_a=25^{\circ}C$)	2800			[Volt] rms	
CCFL Operation Voltage (V_{CFL})	-	1943 (@ 6.0mA)	-	[Volt] rms	Note 5
CCFL Power Consumption (PCFL)	-	70	-	[Watt]	Note 5
CCFL Life Time(LTCFL)	40,000	50,000	-	[Hour]	Note 6

Note 1: Typ. are AUO recommended design points.

- *1 All of characteristics listed are measured under the condition using the AUO test inverter.
- *2 In case of using an inverter other than listed, it is recommended to check the inverter carefully. Sometimes, interfering noise stripes appear on the screen, and substandard luminance or flicker at low power may happen.
- *3 In designing an inverter, it is suggested to check safety circuit very carefully. Impedance of CCFL, for instance, becomes more than 1 [M ohm] when CCFL is damaged.
- *4 Generally, CCFL has some amount of delay time after applying kick-off voltage. It is recommended to keep on applying kick-off voltage for 1 [Sec] until discharge.
- *5 Reducing CCFL current increases CCFL discharge voltage and generally increases CCFL discharge frequency. So all the parameters of an inverter should be carefully designed so as not to produce too much leakage current from high-voltage output of the inverter.

Note 2: It should be employed the inverter which has "Duty Dimming", if IRCFL is less than 4mA.

Note 3: CCFL discharge frequency should be carefully determined to avoid interference between inverter and TFT LCD.

Note 4: The frequency range will not affect to lamp life and reliability characteristics.

Note 5: The variance of CCFL power consumption is $\pm 10\%$. Calculator value for reference ($ISCFL \times VCFL \times 4 = PCFL$)

Note 6: Definition of CCFL life Time (LTCFL): brightness becomes 50%. (The typical life time of CCFL is on the condition at 7.0 mA lamp current).



Product Specification

M255UW02 V0

AU OPTRONICS CORPORATION

5.3 Inverter Electrical Characteristics

Symbol	Parameter	Min.	Typ.	Max.	Unit	Condition	Notes
V_{DDB}	Input Voltage	22.0	24.0	26.0	[V]		Note 1
I_{DDB}	Input Current	-	2.6	3.0	[A]	$V_{BR}=1.65V$	Note 2
P_B	Input Power	-	62.4	72.0	[Watt]	$V_{BR}=1.65V$	Note 2
V_{BR}	Brightness Adjust	0	1.65	3.3	[V]		Note 3 (Analog DIM)
$V_{ON/OFF}$	Backlight on/off control	2	-	5	[V]	Enable the inverter	
		0	-	0.8	[V]	Disable the inverter	

Note 1: The input voltage ripple is limited below 400mVp-p.

Note 2: The specified current and power consumption are under the typical supply input voltage, 24V.

Note 3: ICFL = 6mA when $V_{BR} = 1.65V$ (brightness=100%).

Note 4: The life is determined as the time at which luminance of the lamp is 50% compared to that of initial value at the typical lamp current on condition of continuous operating at $25\pm 2^\circ C$.

Note 5: Electrical characteristics are determined after the unit has been 'ON' and stable for approximately 30min at $25\pm 2^\circ C$.



Product Specification

M255UW02 V0

AU OPTRONICS CORPORATION

6. Signal Characteristic

6.1 Pixel Format Image

Following figure shows the relationship of the input signals and LCD pixel format.

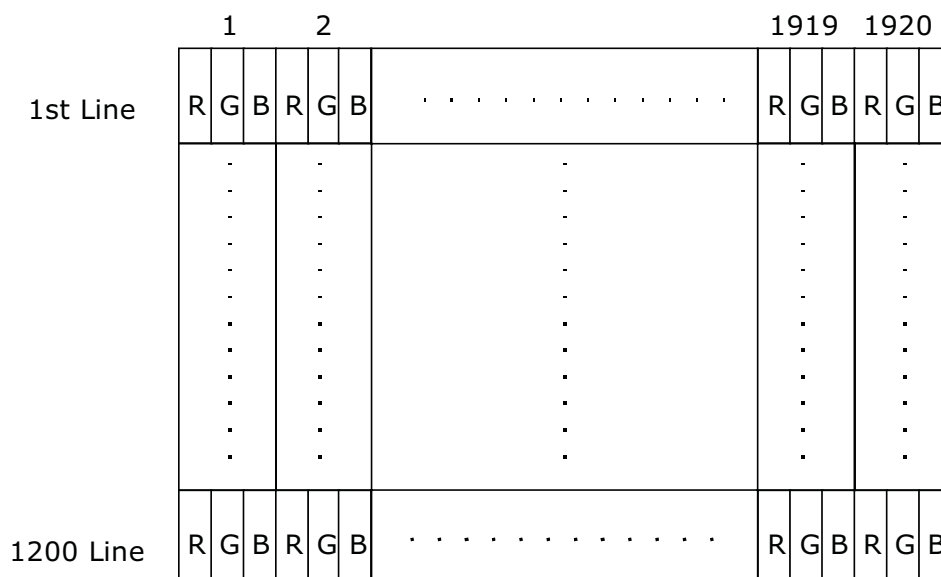

6.2 The Input Data Format

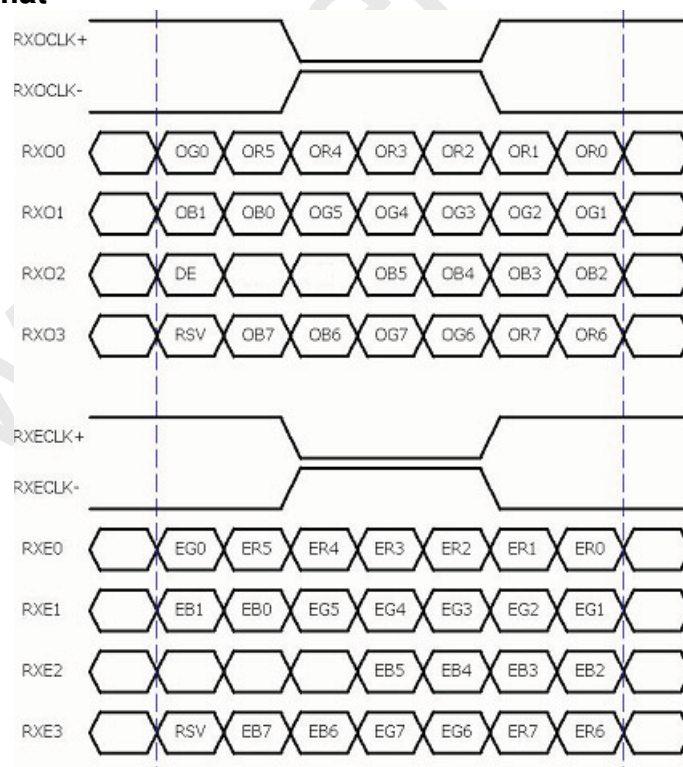

Note 1:

R/G/B data 7: MSB, R/G/B data 0: LSB

O = "First Pixel Data"

E = "Second Pixel Data"



Product Specification

M255UW02 V0

AU OPTRONICS CORPORATION

6.3 Signal Description

The module using a pair of LVDS receiver SN75LVDS82(Texas Instruments) or compatible. LVDS is a differential signal technology for LCD interface and high speed data transfer device. Transmitter shall be SN75LVDS83(negative edge sampling) or compatible. The first LVDS port(RxOxxx) transmits odd pixels while the second LVDS port(RxExxx) transmits even pixels.

PIN #	SIGNAL NAME	DESCRIPTION
1	RxOIN0-	Negative LVDS differential data input (Odd data)
2	RxOIN0+	Positive LVDS differential data input (Odd data)
3	RxOIN1-	Negative LVDS differential data input (Odd data)
4	RxOIN1+	Positive LVDS differential data input (Odd data)
5	RxOIN2-	Negative LVDS differential data input (Odd data, DSPTMG)
6	RxOIN2+	Positive LVDS differential data input (Odd data, DSPTMG)
7	GND	Power Ground
8	RxOCLK-	Negative LVDS differential clock input (Odd clock)
9	RxOCLK+	Positive LVDS differential clock input (Odd clock)
10	RxOIN3-	Negative LVDS differential data input (Odd data)
11	RxOIN3+	Positive LVDS differential data input (Odd data)
12	RxEIN0-	Negative LVDS differential data input (Even data)
13	RxEIN0+	Positive LVDS differential data input (Even data)
14	GND	Power Ground
15	RxEIN1-	Positive LVDS differential data input (Even data)
16	RxEIN1+	Negative LVDS differential data input (Even data)
17	GND	Power Ground
18	RxEIN2-	Negative LVDS differential data input (Even data)
19	RxEIN2+	Positive LVDS differential data input (Even data)
20	RxECLK-	Negative LVDS differential clock input (Even clock)
21	RxECLK+	Positive LVDS differential clock input (Even clock)
22	RxEIN3-	Negative LVDS differential data input (Even data)
23	RxEIN3+	Positive LVDS differential data input (Even data)
24	GND	Power Ground
25	NC	No connection (for AUO test)
26	SPDEN	L(0V): enable; H(3.3V) or floating: disable
27	VDD	Power +5V
28	VDD	Power +5V
29	VDD	Power +5V
30	VDD	Power +5V



Product Specification

M255UW02 V0

AU OPTRONICS CORPORATION

Note1: Start from left side

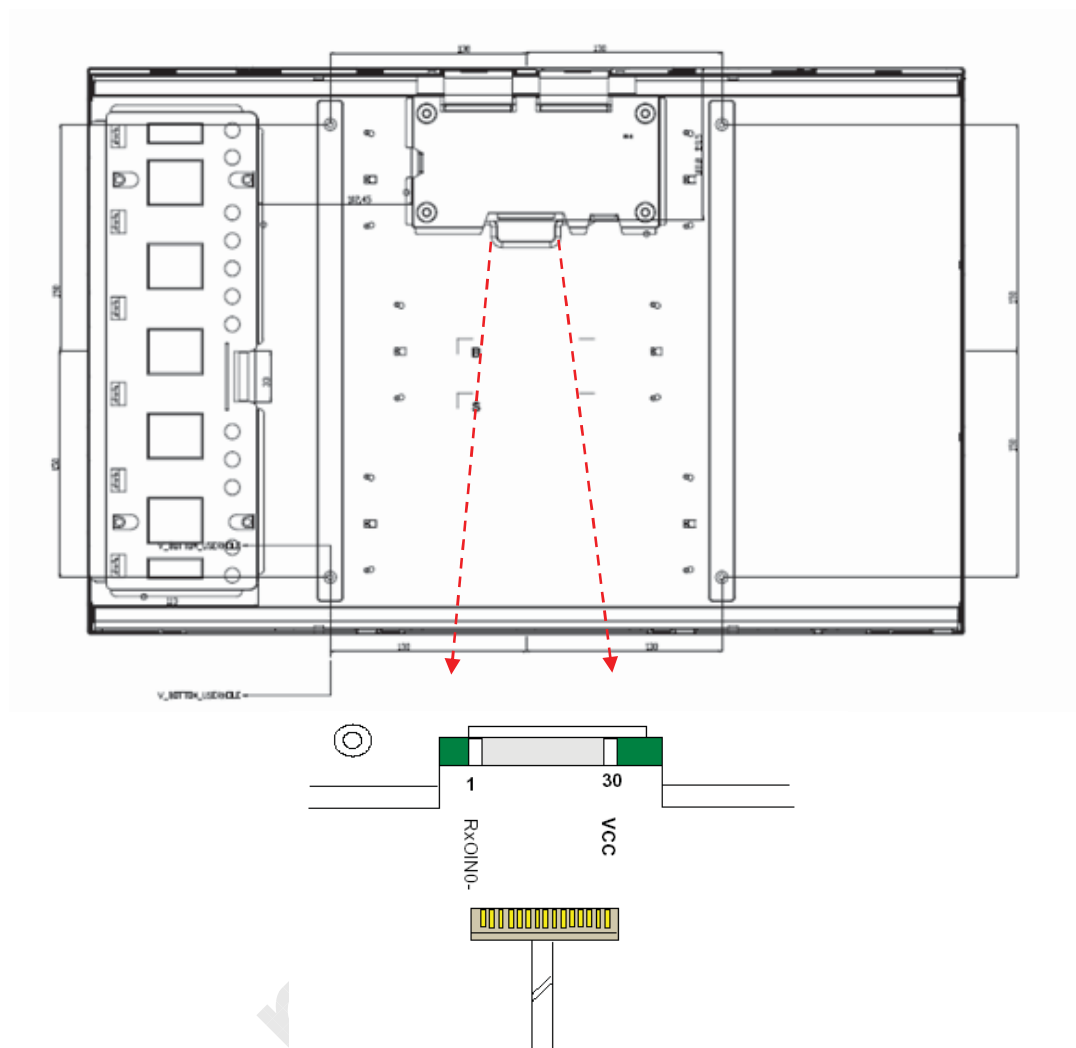

Note2: Input signals of odd and even clock shall be the same timing.



Product Specification

M255UW02 V0

AU OPTRONICS CORPORATION

6.4 Interface Timing

6.4.1 Timing Characteristics

Basically, interface timings described here is not actual input timing of LCD module but output timing of SN75LVDS82DGG (Texas Instruments) or equivalent.

SPD function OFF						
Signal	Item	Symbol	Min	Typ	Max	Unit
Vertical Section	Period	Tv	1210	1212	2048	Th
	Active	Tdisp(v)	1200	1200	1200	Th
	Blanking	Tblk(v)	10	12	-	Th
Horizontal Section	Period	Th	1050	1072	2048	Tclk
	Active	Tdisp(h)	960	960	960	Tclk
	Blanking	Tblk(h)	90	112	-	Tclk
Clock	Period	Tclk	11.76	-	-	ns
	Frequency	Freq	-	-	85	MHz
Frame Rate	Frequency	Vsync	47	60	65	Hz

Note 1: Typical value refer to VESA STANDARD

Note 2: DE mode only.

Note 3: When panel is operated at SPD mode, the timing is recommended at typical value.



Product Specification

M255UW02 V0

AU OPTRONICS CORPORATION

6.4.2 Timing Diagram

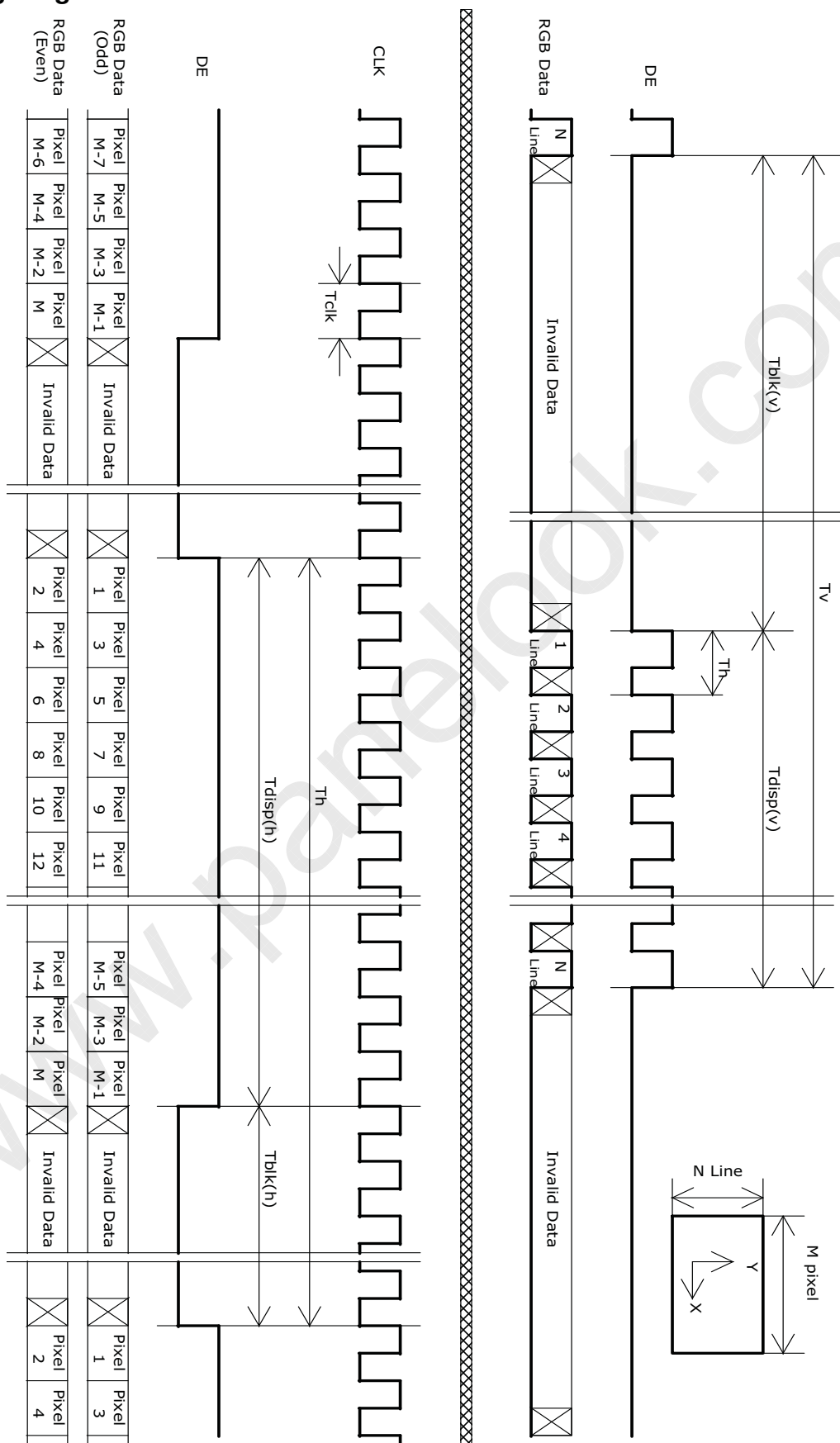



Product Specification

M255UW02 V0

AU OPTRONICS CORPORATION

6.5 Power ON/OFF Sequence

Vin power and lamp on/off sequence is as follows. Interface signals are also shown in the chart. Signals from any system shall be Hi-Z state or low level when Vin is off.

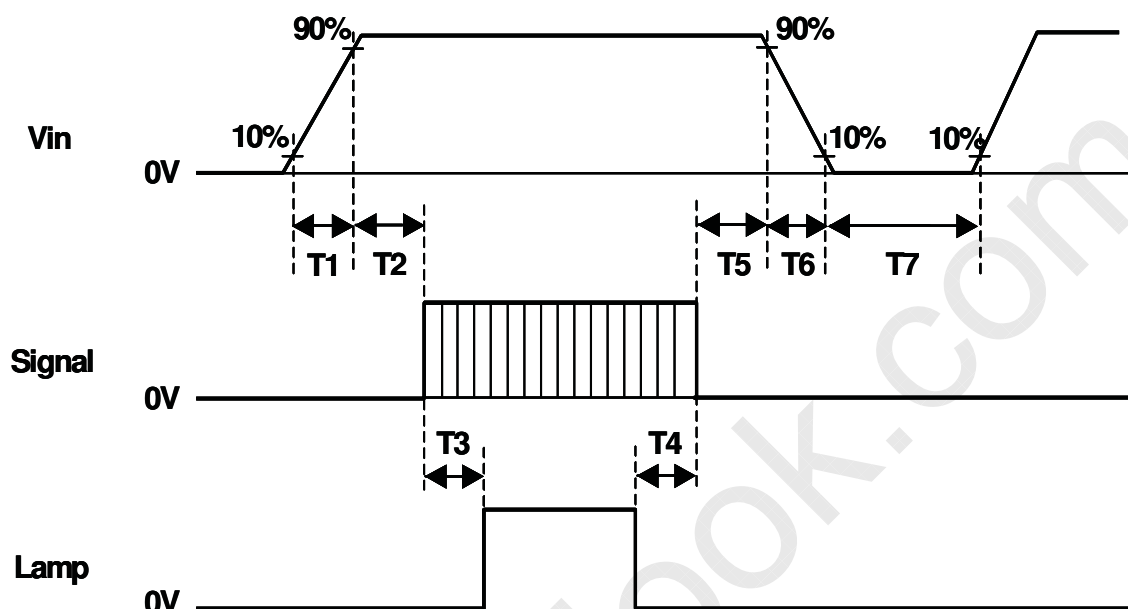

Power Sequence Timing

Parameter	Value			Unit
	Min.	Typ.	Max.	
T1	0.5	-	10	[ms]
T2	0.5	40	50	[ms]
T3	300	-	-	[ms]
T4	300	-	-	[ms]
T5	0.5	16	50	[ms]
T6	0.5	-	60	[ms]
T7	1000	-	-	[ms]



Product Specification

M255UW02 V0

AU OPTRONICS CORPORATION

7. Connector & Pin Assignment

Physical interface is described as for the connector on module. These connectors are capable of accommodating the following signals and will be following components.

7.1 TFT LCD Module

7.1.1 Connector

Connector Name / Designation	Interface Connector / Interface card
Manufacturer	LVDS: JAE or compatible
Type Part Number	FI-X30SSL-HF
Mating Housing Part Number	FI-X30H(Unlocked Type) or FI-X30HL(Locked Type)

7.1.2 Pin Assignment

Pin#	Signal Name	Pin#	Signal Name
1	RxOIN0-	2	RxOIN0+
3	RxOIN1-	4	RxOIN1+
5	RxOIN2-	6	RxOIN2+
7	GND	8	RxOCLKIN-
9	RxOCLKIN+	10	RxOIN3-
11	RxOIN3+	12	RxEIN0-
13	RxEIN0+	14	GND
15	RxEIN1-	16	RxEIN1+
17	GND	18	RxEIN2-
19	RxEIN2+	20	RxECLKIN-
21	RxECLKIN+	22	RxEIN3-
23	RxEIN3+	24	GND
25	NC	26	SPDEN
27	VDD	28	VDD
29	VDD	30	VDD



Product Specification

M255UW02 V0

AU OPTRONICS CORPORATION

7.2 Backlight Unit

Physical interface is described as for the connector on module. These connectors are capable of accommodating the following signals and will be following components.

Connector Name / Designation	Inverter Connector
Manufacturer	JST or compatible
Type Part Number	S14B-PH-SM3-TB
Mating Type Part Number	PHR-14
Connector Name / Designation	Lamp Connector / Backlight lamp
Manufacturer	CviLux
Type Part Number	CP042CP1ML0-LF
Mating Type Part Number	TBD

7.2.1 Signal for Inverter

No	Signal name	Feature
1	VDD	+24V
2	VDD	+24V
3	VDD	+24V
4	VDD	+24V
5	VDD	+24V
6	GND	GND
7	GND	GND
8	GND	GND
9	GND	GND
10	GND	GND
11	Analog DIM (V_{BR})	Analog Dimming mode: (Max.=3.3V, min=0V, type=1.65V or open)
12	BL ON/OFF	ON: 2.0V~5.0V(or open) OFF: 0V~0.8V
13	PWM DIM	Internal PWM Dimming Control. (Max.=3.3V or open, min=0.2V)
14	NC	N.C



Product Specification

M255UW02 V0

AU OPTRONICS CORPORATION

7.2.2 Signal for Lamp connector

Connector	Pin No.	Input	Color	Function
CN1	1	Hot	Pink	High Voltage
	4	Hot	White	High Voltage
CN2	1	Hot	Pink	High Voltage
	4	Hot	White	High Voltage
CN3	1	Hot	Pink	High Voltage
	4	Hot	White	High Voltage
CN4	1	Hot	Pink	High Voltage
	4	Hot	White	High Voltage
CN5	1	Hot	Pink	High Voltage
	4	Hot	White	High Voltage
CN6	1	Hot	Pink	High Voltage
	4	Hot	White	High Voltage



Product Specification

M255UW02 V0

AU OPTRONICS CORPORATION

8. Reliability Test

Environment test conditions are listed as following table.

Items	Required Condition	Note
Temperature Humidity Bias (THB)	Ta= 50°C , 80%RH, 300hours	
High Temperature Operation (HTO)	Ta= 50°C , 300hours	
Low Temperature Operation (LTO)	Ta= 0°C , 300hours	
High Temperature Storage (HTS)	Ta= 60°C , 300hours	
Low Temperature Storage (LTS)	Ta= -20°C , 300hours	
Vibration Test (Non-operation)	Acceleration: 1.5 G Wave: Sine Frequency: 10~300 Hz Sweep: 30 Minutes each Axis (X, Y, Z)	
Shock Test (Non-operation)	Acceleration: 50 G Wave: Half-sine Active Time: 11 ms Direction: ±X, ±Y, ±Z (one time for each Axis)	
Drop Test	Height: 60 cm, package test	
Thermal Shock Test (TST)	-20°C/30min, 60°C/30min, 100 cycles	Note 1
On/Off Test	On/10sec, Off/10sec, 30,000 cycles	
ESD (ElectroStatic Discharge)	Contact Discharge: ± 8KV, 150pF (330Ω) 1sec, 8 points, 25 times/ point.	Note 2
	Air Discharge: ± 15KV, 150pF(330Ω) 1sec, 8 points, 25 times/ point.	
Altitude Test	Operation:10,000 ft Non-Operation:30,000 ft	

Note 1: The TFT-LCD module will not sustain damage after being subjected to 100 cycles of rapid temperature change. A cycle of rapid temperature change consists of varying the temperature from -20°C to 60°C, and back again. Power is not applied during the test. After temperature cycling, the unit is placed in normal room ambient for at least 4 hours before power on.

Note 2: According to EN61000-4-2, ESD class B: Some performance degradation allowed. No data lost. Self-recoverable. No hardware failures.



Product Specification

M255UW02 V0

AU OPTRONICS CORPORATION

9. Shipping Label

The shipping label format is shown as below.

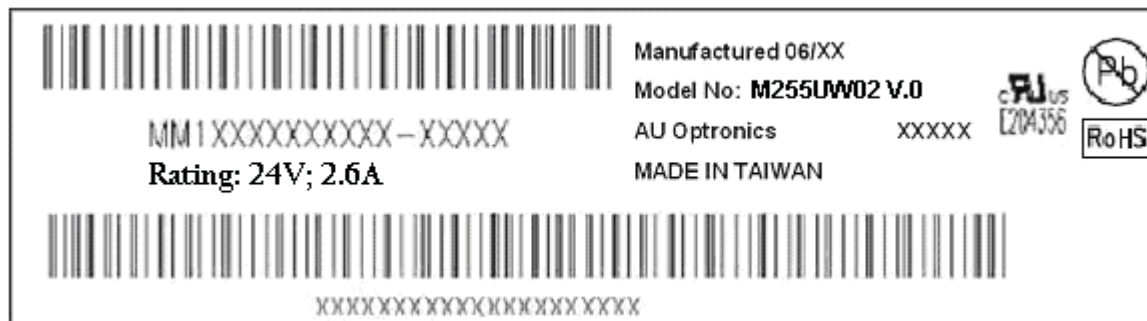



Product Specification

AU OPTRONICS CORPORATION

M255UW02 V0

10. Mechanical Characteristics

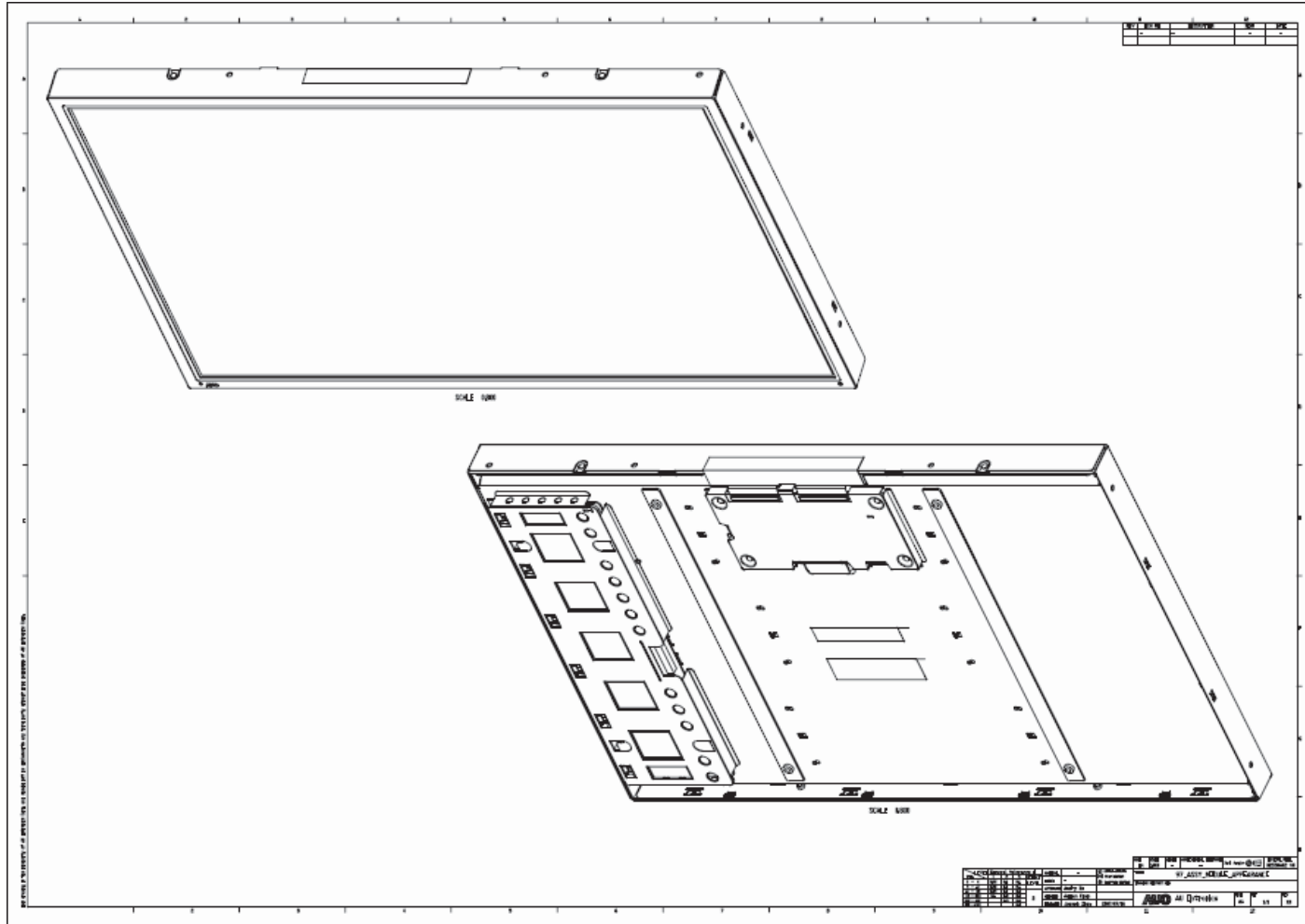



Product Specification

AU OPTRONICS CORPORATION

M255UW02 V0

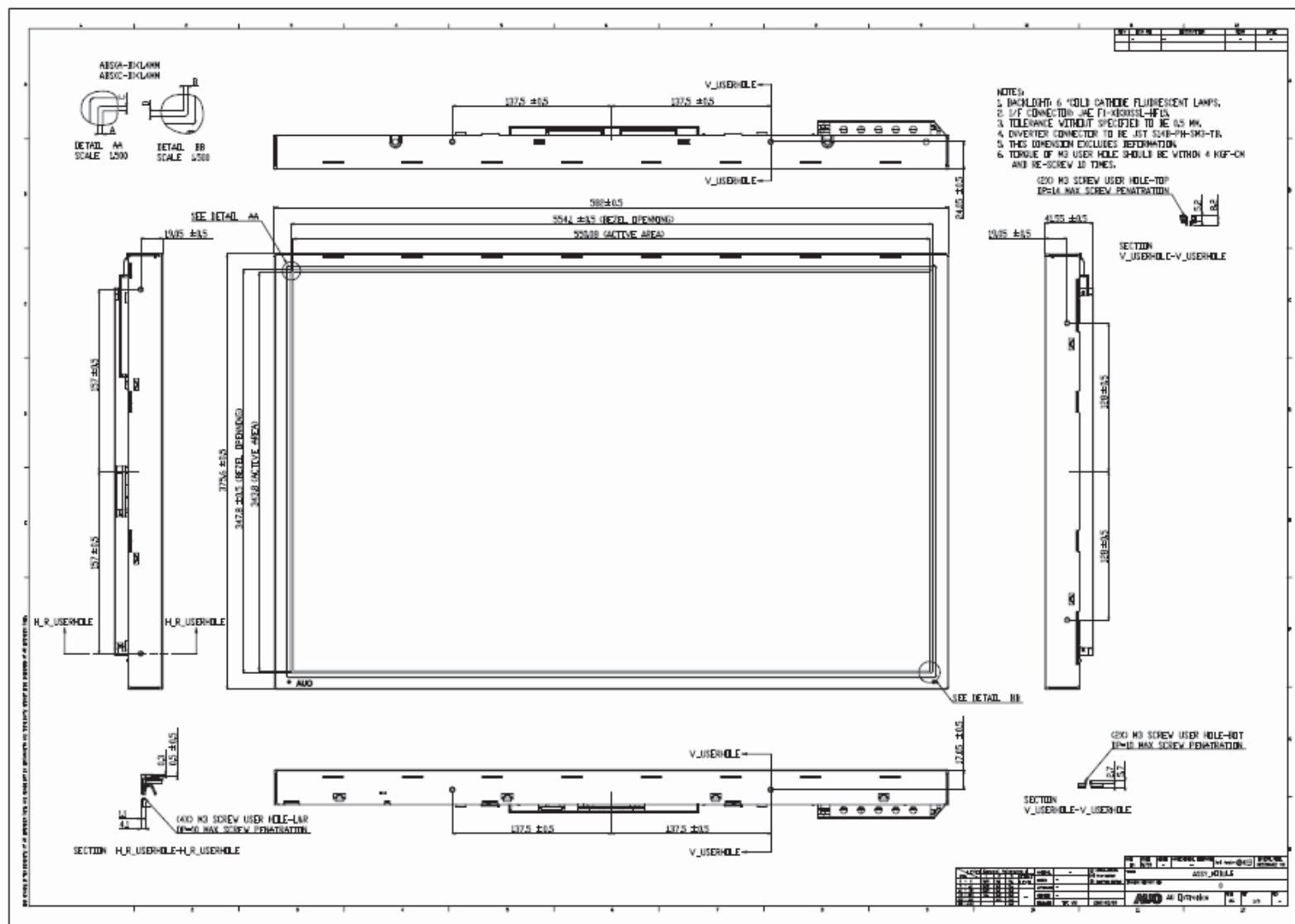



Product Specification

AU OPTRONICS CORPORATION

M255UW02 V0

