

TFT LCD Preliminary Specification

MODEL NO.: M260J1- L07

Customer:	_____
Approved by:	_____
Note:	Reference Only

記錄	工作	審核	角色	投票
2008-02-27 20:09:05 CST	PMMD Director	cs_lee(李志聖 /56510/44926)	Director	Accept

- CONTENTS -

REVISION HISTORY	3
1. GENERAL DESCRIPTION	4
1.1 OVERVIEW	
1.2 FEATURES	
1.3 APPLICATION	
1.4 GENERAL SPECIFICATIONS	
1.5 MECHANICAL SPECIFICATIONS	
2. ABSOLUTE MAXIMUM RATINGS	5
2.1 ABSOLUTE RATINGS OF ENVIRONMENT	
2.2 ELECTRICAL ABSOLUTE RATINGS	
2.2.1 TFT LCD MODULE	
2.2.2 BACKLIGHT UNIT	
3. ELECTRICAL CHARACTERISTICS	8
3.1 TFT LCD MODULE	
3.2 BACKLIGHT UNIT	
4. BLOCK DIAGRAM	12
4.1 TFT LCD MODULE	
4.2 BACKLIGHT UNIT	
5. INPUT TERMINAL PIN ASSIGNMENT	13
5.1 TFT LCD MODULE	
5.2 BACKLIGHT UNIT	
5.3 COLOR DATA INPUT ASSIGNMENT	
6. INVERTER SPECIFICATIONS	16
6.1 INVERTER PIN ASSIGNMENT	
6.2 INVERTER ELECTRONIC SPECIFICATION	
6.3 INVERTER ABSOLUTE MAXIMUM RATINGS	
7. INTERFACE TIMING	19
7.1 INPUT SIGNAL TIMING SPECIFICATIONS	
7.2 POWER ON/OFF SEQUENCE	
7.3 VDD POWER DIP CONDITION	
8. OPTICAL CHARACTERISTICS	21
8.1 TEST CONDITIONS	
8.2 OPTICAL SPECIFICATIONS	
9. PACKAGING	26
9.1 PACKING SPECIFICATIONS	
9.2 PACKING METHOD	
10. DEFINITION OF LABELS	28
11. PRECAUTIONS	29
11.1 ASSEMBLY AND HANDLING PRECAUTIONS	
11.2 SAFETY PRECAUTIONS	
12. MECHANICAL CHARACTERISTICS	30

REVISION HISTORY

Version	Date	Section	Description
Ver. 1.0	Feb. 22, 08'	-	M260J1 -L07 Preliminary specifications was first issued.

1. GENERAL DESCRIPTION

1.1 OVERVIEW

M260J1-L07 is a 25.54 inches TFT Liquid Crystal Display module with 16 CCFL Backlight unit and 30 pins 2 channels LVDS interface. This module supports 1920 x 1200 WUXGA mode, DCR 6000:1(Dynamic Contrast Ratio), scan backlight technique (clear motion picture), and display up to 16.7 millions colors. The inverter module for Backlight is built in.

1.2 FEATURES

- Super MVA extra-wide viewing angle.
- High Static Contrast Ratio 1500:1/Dynamic Contrast ratio 6000:1 (DCR).
- Fast response time.
- High color saturation.
- Low color shift
- WUXGA (1920 x 1200 pixels) resolution.
- DE (Data Enable) only mode.
- LVDS (Low Voltage Differential Signaling) interface.
- RoHS compliance.
- TCO'03 compliance.
- DCR & Scan function supported by the inverter module that built-in the backlight unit.

1.3 APPLICATION

- TFT LCD Monitor

1.4 GENERAL SPECIFICATIONS

Item	Specification	Unit	Note
Active Area	550.08 (H) x 343.8 (V) (25.54" diagonal)	mm	(1)
Bezel Opening Area	554.1 (H) x 347.8 (V)	mm	
Driver Element	a-Si TFT active matrix	-	-
Pixel Number	1920 x R.G.B. x 1200	pixel	-
Pixel Pitch	0.2865 (H) x 0.2865 (V)	mm	-
Pixel Arrangement	RGB vertical stripe	-	-
Display Colors	16.7M	color	-
Transmissive Mode	Normally black	-	-
Surface Treatment	AG type, 3H hard coating, Haze 25	-	-

1.5 MECHANICAL SPECIFICATIONS

Item	Min.	Typ.	Max.	Unit	Note	
Module Size	Horizontal(H)	581.5	582.0	582.5	mm	(1)
	Vertical(V)	375.1	375.6	376.1	mm	
	Depth(D)	41.9	42.4	42.9	mm	
Weight	-	-	3450	g	-	

Note (1) Please refer to the attached drawings for more information of front and back outline dimensions.

2. ABSOLUTE MAXIMUM RATINGS

2.1 ABSOLUTE RATINGS OF ENVIRONMENT

Item	Symbol	Value		Unit	Note
		Min.	Max.		
Storage Temperature	T _{ST}	-20	60	°C	(1)
Operating Ambient Temperature	T _{OP}	0	50	°C	(1), (2)
Shock (Non-Operating)	S _{NOP}	-	40	G	(3), (5)
Vibration (Non-Operating)	V _{NOP}	-	1.5	G	(4), (5)

Note (1) Temperature and relative humidity range is shown in the figure below.

(a) 90 %RH Max. ($T_a \leq 40$ °C).

(b) Wet-bulb temperature should be 39 °C Max. ($T_a > 40$ °C).

(c) No condensation.

Note (2) The temperature of panel display surface area should be 0 °C Min. and 60 °C Max.

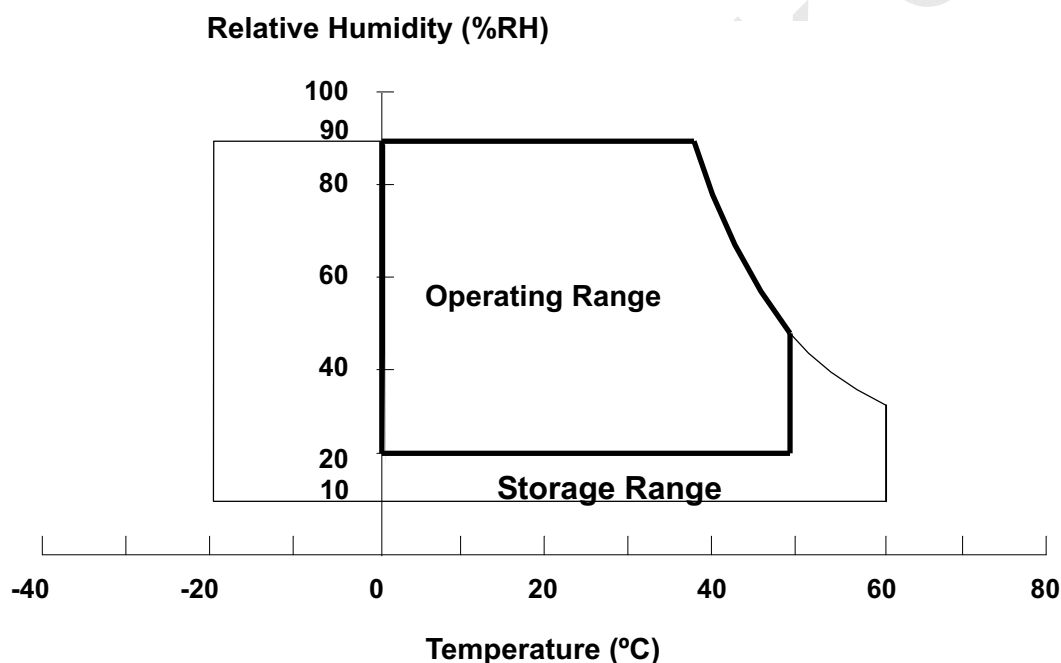

Note (3) 11 ms, half sine wave, 1 time for $\pm X$, $\pm Y$, $\pm Z$.

Note (4) 10 ~ 300 Hz, 10min/cycle, 3 cycles each X, Y, Z.

Note (5) At testing Vibration and Shock, the top and bottom side of the module must be held by the bracket.

The fixture in holding the module has to be hard and rigid enough so that the module would not be twisted or bent by the fixture.

The fixing condition is shown as below:

The fixing condition is shown as below:

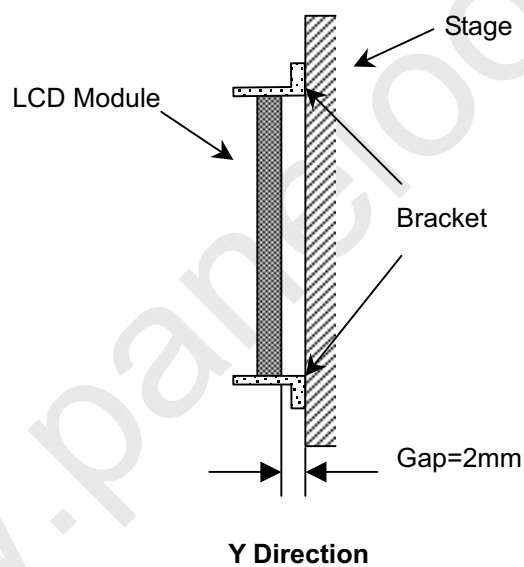
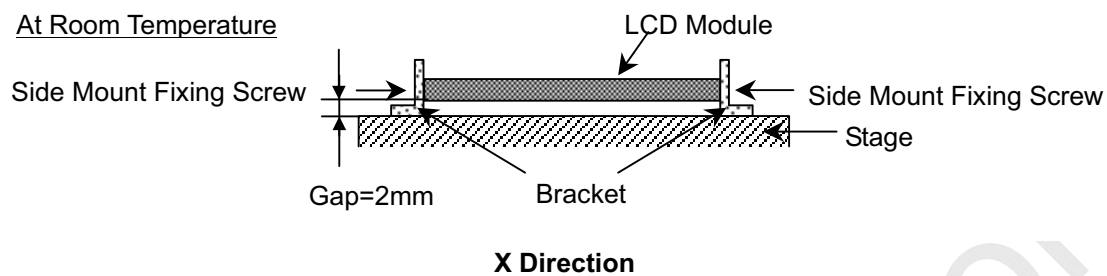

2.2 ELECTRICAL ABSOLUTE RATINGS

2.2.1 TFT LCD MODULE

Item	Symbol	Value		Unit	Note
		Min.	Max.		
Power Supply Voltage	Vcc	-0.3	+6.0	V	(1)

2.2.2 BACKLIGHT UNIT

Item	Symbol	Value		Unit	Note
		Min.	Max.		
Lamp Voltage	V _L	-	2.5K	V _{RMS}	(1), (2)
Lamp Current	I _L	-	5.5	mA _{RMS}	(1), (2)
Lamp Frequency	F _L	-	70	KHz	

Note (1) Permanent damage to the device may occur if maximum values are exceeded. Function operation should be restricted to the conditions described under Normal Operating Conditions.

Note (2) Specified values are for lamp (Refer to 3.2 for further information).

3. ELECTRICAL CHARACTERISTICS

3.1 TFT LCD MODULE

 $T_a = 25 \pm 2 \text{ }^\circ\text{C}$

Parameter	Symbol	Value			Unit	Note
		Min.	Typ.	Max.		
Power Supply Voltage	V _{CC}	4.5	5.0	5.5	V	-
Ripple Voltage	V _{RP}	-	-	100	mV	-
Rush Current	I _{RUSH}	-	-	(3.8)	A	(2)
Power Supply Current	White	-	(2.1)	-	A	(3)a
	Black	-	(1.1)	-	A	(3)b
	Vertical Stripe	-	(1.96)	-	A	(3)c
LVDS differential input voltage	V _{id}	100	-	600	mV	
LVDS common input voltage	V _{ic}	-	1.2	-	V	

Note (1) The module should be always operated within above ranges.

Note (2) Measurement Conditions:

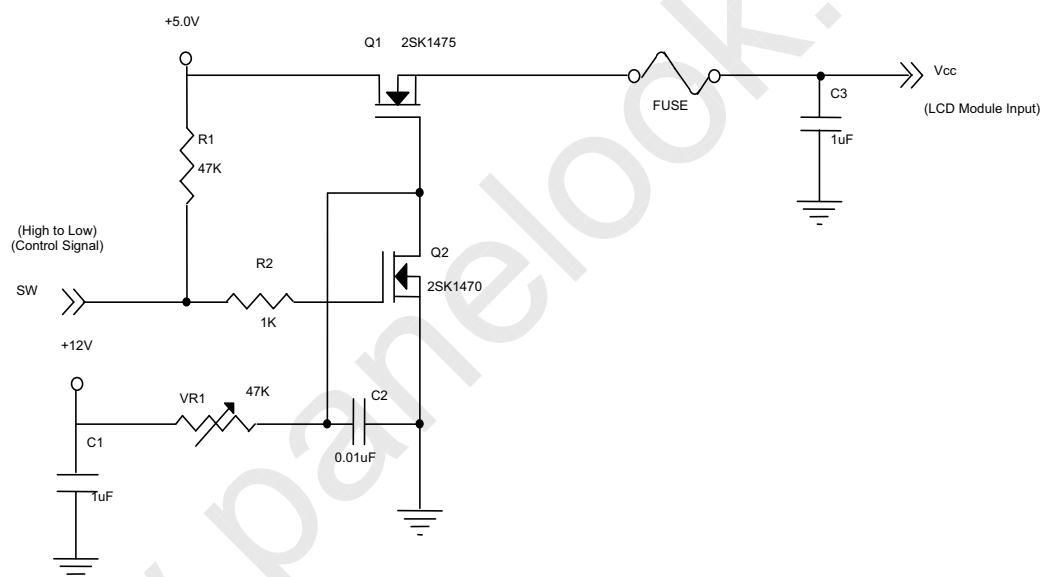

V_{CC} rising time is 470 μ s

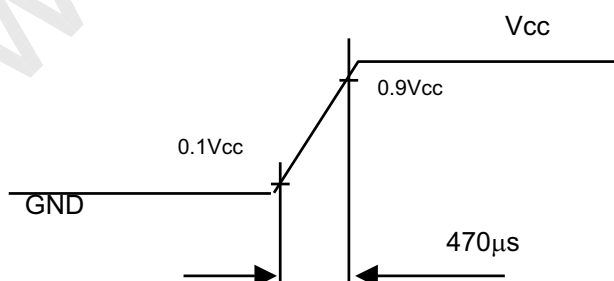

Note (3) The specified power supply current is under the conditions at $V_{cc} = 5.0\text{ V}$, $T_a = 25 \pm 2\text{ }^\circ\text{C}$, $f_v = 60\text{ Hz}$, whereas a power dissipation check pattern below is displayed.

a. White Pattern

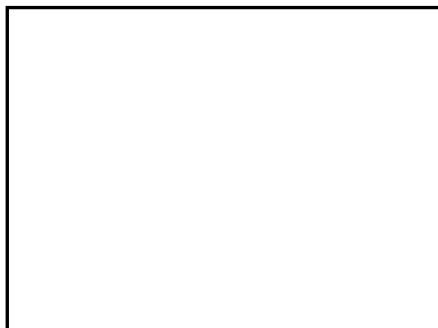

Active Area

b. Black Pattern



Active Area

c. Vertical Stripe Pattern

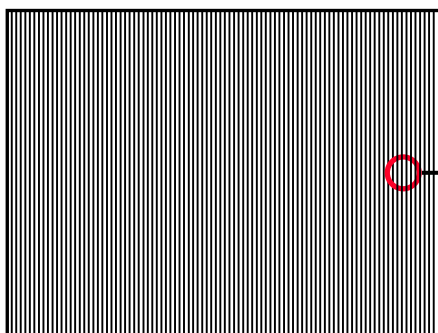

Active Area

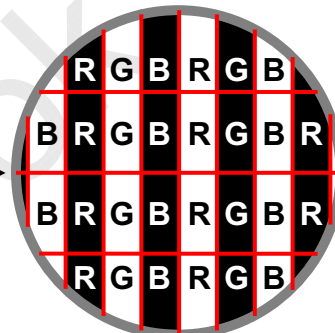

3.2 BACKLIGHT UNIT

Ta = 25 ± 2 °C

Parameter	Symbol	Value			Unit	Note
		Min.	Typ.	Max.		
Lamp Input Voltage	V _L	932	1036	1140	V _{RMS}	I _L = 5.0 mA
Lamp Current	I _L	4.5	5.0	5.5	mA _{RMS}	(1)
Lamp Turn On Voltage	V _S	-	-	1920 (0°C)	V _{RMS}	(2)
		-	-	1620 (25°C)	V _{RMS}	(2)
Operating Frequency	F _L	48	55	70	KHz	(3)
Lamp Life Time	L _{BL}	50,000	-	-	Hrs	(5), I _L = 5.0mA
Power Consumption	P _L	-	83	-	W	(4), I _L = 5.0 mA

Note (1) Lamp current is measured by current amplify & oscilloscope as shown below:

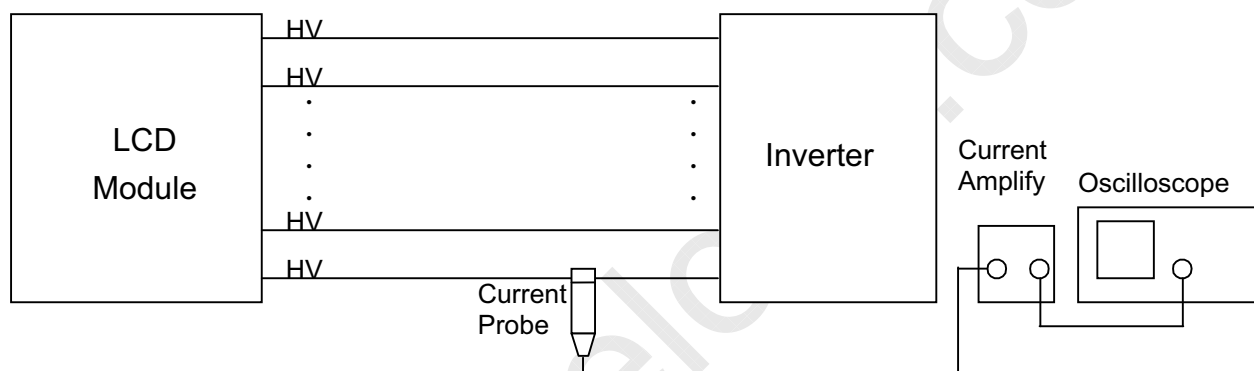

Measure equipment:

Current Amplify: Tektronix TCPA300

Current probe: Tektronix TCP312

Oscilloscope: TDS3054B

Note (2) The voltage that must be larger than V_S should be applied to the lamp for more than 1 second after startup. Otherwise, the lamp may not be turned on normally.

Note (3) The lamp frequency may produce interference with horizontal synchronization frequency from the display, which might cause line flow on the display. In order to avoid interference, the lamp frequency should be detached from the horizontal synchronization frequency and its harmonics as far as possible.

Note (4) P_L = I_L × V_L × 16

Note (5) The lifetime of lamp can be defined as the time in which it continues to operate under the condition Ta = 25 ± 2 °C and I_L = 5.0 mA_{RMS} until one of the following events occurs:

(a) When the brightness becomes or lowers than 50% of its original value.

(b) When the effective ignition length becomes or lowers than 80% of its original value. (The effective ignition length is a scope that luminance is over 70% of that at the center point.)

Note (6) The waveform of the voltage output of inverter must be area-symmetric and the design of the inverter must have specifications for the modularized lamp. The performance of the Backlight, such as lifetime or brightness, is greatly influenced by the characteristics of the DC-AC inverter for

the lamp. All the parameters of an inverter should be carefully designed to avoid producing too much current leakage from high voltage output of the inverter. When designing or ordering the inverter please make sure that a poor lighting caused by the mismatch of the Backlight and the inverter (miss-lighting, flicker, etc.) never occurs. If the above situation is confirmed, the module should be operated in the same manners when it is installed in your instrument.

The output of the inverter must have symmetrical (negative and positive) voltage waveform and symmetrical current waveform. (Unsymmetrical ratio is less than 10%) Please do not use the inverter which has unsymmetrical voltage and unsymmetrical current and spike wave. Lamp frequency may produce interface with horizontal synchronous frequency and as a result this may cause beat on the display. Therefore lamp frequency shall be as away possible from the horizontal synchronous frequency and from its harmonics in order to prevent interference.

Requirements for a system inverter design, which is intended to have a better display performance, a better power efficiency and a more reliable lamp. It shall help increase the lamp lifetime and reduce its leakage current.

- The asymmetry rate of the inverter waveform should be 10% below;
- The distortion rate of the waveform should be within $\sqrt{2} \pm 10\%$;
- The ideal sine wave form shall be symmetric in positive and negative polarities

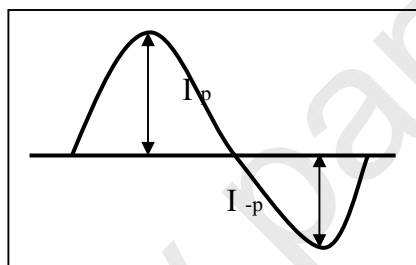

* Asymmetry rate:

$$\frac{|I_p - I_{-p}|}{I_{rms}} * 100\%$$

* Distortion rate

$$I_p \text{ (or } I_{-p}) / I_{rms}$$

4. BLOCK DIAGRAM

4.1 TFT LCD MODULE

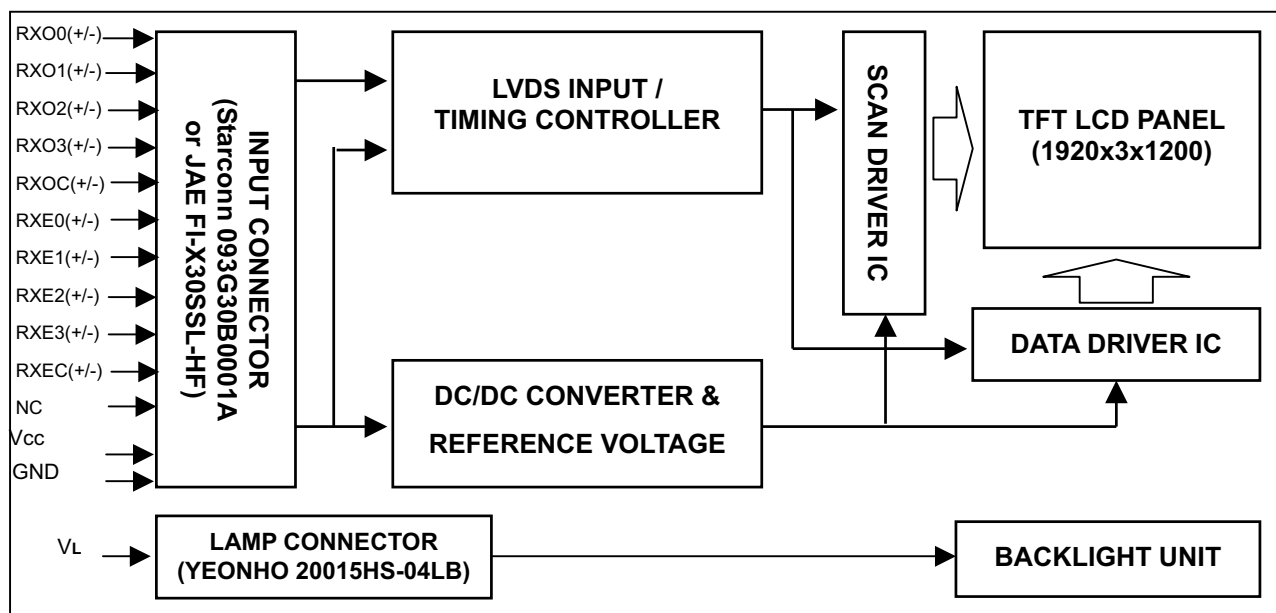

4.2 BACKLIGHT UNIT

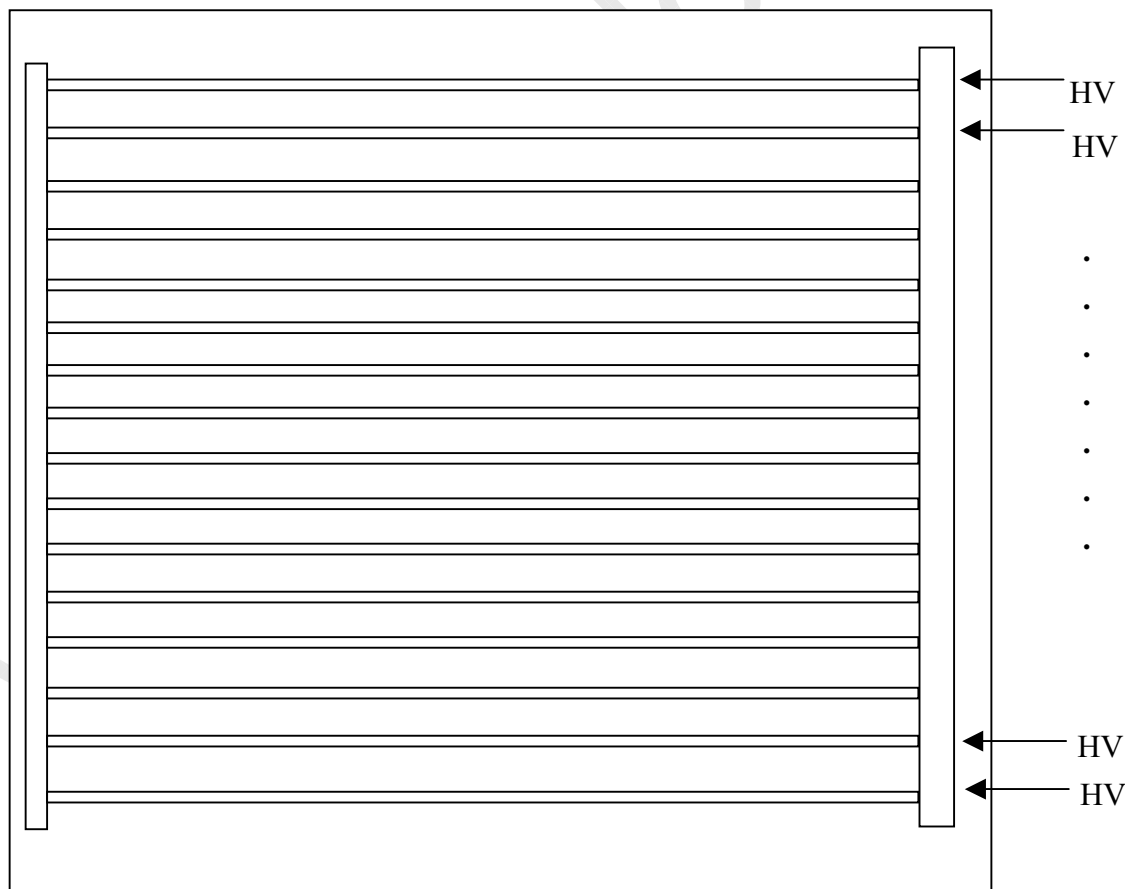

Note: On the same side, the same polarity lamp voltage design for lamps is recommended.

5. INPUT TERMINAL PIN ASSIGNMENT

5.1 TFT LCD MODULE

Pin	Name	Description
1	RXO0-	Negative LVDS differential data input. Channel O0 (odd)
2	RXO0+	Positive LVDS differential data input. Channel O0 (odd)
3	RXO1-	Negative LVDS differential data input. Channel O1 (odd)
4	RXO1+	Positive LVDS differential data input. Channel O1 (odd)
5	RXO2-	Negative LVDS differential data input. Channel O2 (odd)
6	RXO2+	Positive LVDS differential data input. Channel O2 (odd)
7	GND	Ground
8	RXOC-	Negative LVDS differential clock input. (odd)
9	RXOC+	Positive LVDS differential clock input. (odd)
10	RXO3-	Negative LVDS differential data input. Channel O3(odd)
11	RXO3+	Positive LVDS differential data input. Channel O3 (odd)
12	RXE0-	Negative LVDS differential data input. Channel E0 (even)
13	RXE0+	Positive LVDS differential data input. Channel E0 (even)
14	GND	Ground
15	RXE1-	Negative LVDS differential data input. Channel E1 (even)
16	RXE1+	Positive LVDS differential data input. Channel E1 (even)
17	GND	Ground
18	RXE2-	Negative LVDS differential data input. Channel E2 (even)
19	RXE2+	Positive LVDS differential data input. Channel E2 (even)
20	RXEC-	Negative LVDS differential clock input. (even)
21	RXEC+	Positive LVDS differential clock input. (even)
22	RXE3-	Negative LVDS differential data input. Channel E3 (even)
23	RXE3+	Positive LVDS differential data input. Channel E3 (even)
24	GND	Ground
25	NC	No connection, this pin should be opened.
26	NC	No connection, this pin should be opened.
27	Vcc	+5.0V power supply
28	Vcc	+5.0V power supply
29	Vcc	+5.0V power supply
30	Vcc	+5.0V power supply

Note (1) Connector Part No.: STARCONN 093G30-B0001A or JAE FI-X30SSL-HF.

Note (2) The first pixel is odd.

Note (3) Input signal of even and odd clock should be the same timing.

LVDS Channel O0	LVDS output	D7	D6	D4	D3	D2	D1	D0
	Data order	OG0	OR5	OR4	OR3	OR2	OR1	OR0
LVDS Channel O1	LVDS output	D18	D15	D14	D13	D12	D9	D8
	Data order	OB1	OB0	OG5	OG4	OG3	OG2	OG1
LVDS Channel O2	LVDS output	D26	D25	D24	D22	D21	D20	D19
	Data order	DE	NA	NA	OB5	OB4	OB3	OB2
LVDS Channel O3	LVDS output	D23	D17	D16	D11	D10	D5	D27
	Data order	NA	OB7	OB6	OG7	OG6	OR7	OR6
LVDS Channel E0	LVDS output	D7	D6	D4	D3	D2	D1	D0
	Data order	EG0	ER5	ER4	ER3	ER2	ER1	ER0
LVDS Channel E1	LVDS output	D18	D15	D14	D13	D12	D9	D8
	Data order	EB1	EB0	EG5	EG4	EG3	EG2	EG1
LVDS Channel E2	LVDS output	D26	D25	D24	D22	D21	D20	D19
	Data order	DE	NA	NA	EB5	EB4	EB3	EB2
LVDS Channel E3	LVDS output	D23	D17	D16	D11	D10	D5	D27
	Data order	NA	EB7	EB6	EG7	EG6	ER7	ER6

5.2 BACKLIGHT UNIT:

Pin	Symbol	Description	Remark
1-1	HV	High Voltage	Blue
1-2	HV	High Voltage	White
2-3	HV	High Voltage	Pink
2-4	HV	High Voltage	White
3-5	HV	High Voltage	Blue
3-6	HV	High Voltage	White
4-7	HV	High Voltage	Pink
4-8	HV	High Voltage	White
5-9	HV	High Voltage	Blue
5-10	HV	High Voltage	White
6-11	HV	High Voltage	Pink
6-12	HV	High Voltage	White
7-13	HV	High Voltage	Blue
7-14	HV	High Voltage	White
8-15	HV	High Voltage	Pink
8-16	HV	High Voltage	White

Note (1) Connector Part No.: YEONHO 20015HS-04LB or equivalent.



Preliminary

5.3 COLOR DATA INPUT ASSIGNMENT

The brightness of each primary color (red, green and blue) is based on the 8-bit gray scale data input for the color. The higher the binary input, the brighter the color. The table below provides the assignment of color versus data input.

Color		Data Signal																							
		Red								Green								Blue							
		R7	R6	R5	R4	R3	R2	R1	R0	R7	R6	G5	G4	G3	G2	G1	G0	R7	R6	B5	B4	B3	B2	B1	B0
Basic Colors	Black	0	0	0	0	0	0	0	0	0	0	0	0	0	0	0	0	0	0	0	0	0	0	0	0
	Red	1	1	1	1	1	1	1	1	0	0	0	0	0	0	0	0	0	0	0	0	0	0	0	0
	Green	0	0	0	0	0	0	0	0	1	1	1	1	1	1	1	1	0	0	0	0	0	0	0	0
	Blue	0	0	0	0	0	0	0	0	0	0	0	0	0	0	0	0	1	1	1	1	1	1	1	1
	Cyan	0	0	0	0	0	0	0	0	1	1	1	1	1	1	1	1	1	1	1	1	1	1	1	1
	Magenta	1	1	1	1	1	1	1	1	0	0	0	0	0	0	0	0	1	1	1	1	1	1	1	1
	Yellow	1	1	1	1	1	1	1	1	1	1	1	1	1	1	1	1	0	0	0	0	0	0	0	0
	White	1	1	1	1	1	1	1	1	1	1	1	1	1	1	1	1	1	1	1	1	1	1	1	1
Gray Scale Of Red	Red(0) / Dark	0	0	0	0	0	0	0	0	0	0	0	0	0	0	0	0	0	0	0	0	0	0	0	0
	Red(1)	0	0	0	0	0	0	0	1	0	0	0	0	0	0	0	0	0	0	0	0	0	0	0	0
	Red(2)	0	0	0	0	0	0	1	0	0	0	0	0	0	0	0	0	0	0	0	0	0	0	0	0
	:	:	:	:	:	:	:	:	:	:	:	:	:	:	:	:	:	:	:	:	:	:	:	:	:
	:	:	:	:	:	:	:	:	:	:	:	:	:	:	:	:	:	:	:	:	:	:	:	:	:
	:	:	:	:	:	:	:	:	:	:	:	:	:	:	:	:	:	:	:	:	:	:	:	:	:
	Red(253)	1	1	1	1	1	1	0	1	0	0	0	0	0	0	0	0	0	0	0	0	0	0	0	0
	Red(254)	1	1	1	1	1	1	1	0	0	0	0	0	0	0	0	0	0	0	0	0	0	0	0	0
Red(255)	1	1	1	1	1	1	1	1	0	0	0	0	0	0	0	0	0	0	0	0	0	0	0	0	
Gray Scale Of Green	Green(0) / Dark	0	0	0	0	0	0	0	0	0	0	0	0	0	0	0	0	0	0	0	0	0	0	0	0
	Green(1)	0	0	0	0	0	0	0	0	0	0	0	0	0	0	1	0	0	0	0	0	0	0	0	0
	Green(2)	0	0	0	0	0	0	0	0	0	0	0	0	0	0	1	0	0	0	0	0	0	0	0	0
	:	:	:	:	:	:	:	:	:	:	:	:	:	:	:	:	:	:	:	:	:	:	:	:	:
	:	:	:	:	:	:	:	:	:	:	:	:	:	:	:	:	:	:	:	:	:	:	:	:	:
	:	:	:	:	:	:	:	:	:	:	:	:	:	:	:	:	:	:	:	:	:	:	:	:	:
	Green(253)	0	0	0	0	0	0	0	1	1	1	1	1	1	1	0	1	0	0	0	0	0	0	0	0
	Green(254)	0	0	0	0	0	0	0	1	1	1	1	1	1	1	1	0	0	0	0	0	0	0	0	0
Green(255)	0	0	0	0	0	0	0	1	1	1	1	1	1	1	1	1	0	0	0	0	0	0	0	0	
Gray Scale Of Blue	Blue(0) / Dark	0	0	0	0	0	0	0	0	0	0	0	0	0	0	0	0	0	0	0	0	0	0	0	0
	Blue(1)	0	0	0	0	0	0	0	0	0	0	0	0	0	0	0	0	0	0	0	0	0	0	0	1
	Blue(2)	0	0	0	0	0	0	0	0	0	0	0	0	0	0	0	0	0	0	0	0	0	0	1	0
	:	:	:	:	:	:	:	:	:	:	:	:	:	:	:	:	:	:	:	:	:	:	:	:	:
	:	:	:	:	:	:	:	:	:	:	:	:	:	:	:	:	:	:	:	:	:	:	:	:	:
	:	:	:	:	:	:	:	:	:	:	:	:	:	:	:	:	:	:	:	:	:	:	:	:	:
	Blue(253)	0	0	0	0	0	0	0	0	0	0	0	0	0	0	0	1	1	1	1	1	1	1	0	1
	Blue(254)	0	0	0	0	0	0	0	0	0	0	0	0	0	0	0	1	1	1	1	1	1	1	1	0
Blue(255)	0	0	0	0	0	0	0	0	0	0	0	0	0	0	0	1	1	1	1	1	1	1	1	1	

Note (1) 0: Low Level Voltage, 1: High Level Voltage

6. INVERTERS SPECIFICATIONS

6.1 INVERTER PIN ASSIGNMENT

6.1.1 Output Connector

CNA, CNB, CNC, CND, CNE, CNG, CNH, CNF: YEONHO 20015WR-07B

Pin No.	Description
1	High voltage output
2	High voltage output

6.1.2 Input Connector

CN1: Yeonho 20022WR-14AML

Pin No.	Symbol	Description
1	V _{in}	+24V
2		
3		
4		
5		
6	GND	Grounding
7		
8		
9		
10	SGND	Signal Grounding
11	DCR On/Off	DCR On/Off control
12	Inverter On/Off	Inverter On/Off control
13	DIMDC	Dimming DC input
14	Scan On/Off	Scan On/Off control

CN3: Aces 88357-0800N

Pin No.	Symbol	Description
1	STV	STV
2	DCR On/Off	DCR On/Off control
3	Scan On/Off	Scan On/Off control
4	DIMPWM	Dimming PWM input
5	DIMOUT	Dimming Output
6	SGND	Signal Grounding
7	NC	NC
8	NC	NC

6.2 INVERTER ELECTRONIC SPECIFICATION (Ta = 25°C) BLU: CMO M260J1-L07

Symbol	Description	Min.	Typ.	Max.	Unit	Note
V _{in}	Input Voltage	21.6	24	26.4	V	
I _{in}	Input Current	1.2	--	4	A	
DCR On/Off	DCR On/Off control: Off	0	--	0.8	V	
	DCR On/Off control: On	2	--	5	V	
Inverter On/Off	Inverter On/Off control: Off	0	--	0.8	V	
	Inverter On/Off control: On	2	--	5	V	
Scan On/Off	Scan On/Off control: Off	0	--	0.8	V	
	Scan On/Off control: On	2	--	5	V	
DIMDC	Dimming DC input	0	--	3.3	V	Note1,2
STV	Start Pulse Vertical amplitude	2	--	3.3	V	
	Start Pulse Vertical frequency	59	60	61	Hz	Note3
DIMPWM	Dimming PWM input @ 160Hz (Scan off, DCR off)	25	--	99.5	%	
	Dimming PWM input @ 240Hz (Scan on/off, DCR on)	--	--	99.5	%	
	Dimming PWM input @ 60Hz (Scan on, DCR off)	12.5	--	50	%	
DIMOUT	Dimming Output (DCR off)	25	--	99.5	%	
	Dimming Output (DCR on)	--	--	99.5	%	
Fb	Burst mode frequency (Scan Off, DCR Off)	146	160	176	Hz	
	Burst mode frequency (Scan Off, DCR On)	230	240	250	Hz	
Freq	Operating frequency	53	55	57	KHz	
I _{lamp}	Lamp current @ DIMPWM 99.5% (Scan Off, DCR On/Off)	5.0	6.0	7.0	mA	
	Lamp current @ DIMPWM 25% @ 160Hz (Scan Off, DCR Off)	2.6	3.1	3.6	mA	
	Lamp current @ DIMPWM 25% @ 240Hz (Scan Off, DCR On)	2.6	3.1	3.6	mA	
	Lamp current @ DIMPWM 50% (Scan mode)	8.4	8.9	9.4	mA	
	Lamp current @ DIMPWM 12.5% (Scan mode)	4.0	4.5	5.0	mA	
V _{lamp}	Lamp voltage	---	1024	---	Vrms	
V _{Start}	Lamp ignition voltage	1800	--	2200	Vrms	

Note1: If DIMDC over 3.6V, the inverter will be damaged.

Note2: If DIMDC ripple voltage over 20mV. The BLU will be seen flicker.

Note3: If STV frequency under 57Hz or over 63Hz, the inverter works abnormally.

6.3 INVERTER ABSOLUTE MAXIMUM RATINGS

No	Item	Symbol	Test Condition	Min.	Type	Max.	Unit	Note
1	Input Voltage	V_{in}	—	0	—	30	V	
2	Dimming DC input	DIMDC	—	-0.3	—	3.6	V	Note1
3	Inverter On/Off control	Inverter On/Off	—	-0.3	—	7	V	
4	Dimming PWM input	DIMPWM	—					
5	Scan On/Off control	Scan On/Off	—					
6	DCR On/Off control	DCR On/Off	—					
7	STV Signal	STV	—					
8	Operating Temperature	TOP	5%~90%RH	0	—	40	°C	Note2
9	Storage Temperature	TST	5%~95%RH	-30	—	80	°C	

Note1: If DIMDC is over 3.6V, the inverter may be damaged.

Note2: Protect inverters from moisture condensation and freezing.

7. INTERFACE TIMING

7.1 INPUT SIGNAL TIMING SPECIFICATIONS

The input signal timing specifications are shown as the following table and timing diagram.

Signal	Item	Symbol	Min.	Typ.	Max.	Unit	Note
LVDS Clock	Frequency	Fc	50.0	77	83.0	MHz	-
	Period	Tc	-	13.0	-	ns	
	High Time	Tch	-	4/7	-	Tc	-
	Low Time	Tcl	-	3/7	-	Tc	-
LVDS Data	Setup Time	Tlvs	600	-	-	ps	-
	Hold Time	Tlvh	600	-	-	ps	-
Vertical Active Display Term	Frame Rate (Scan & DCR Off)	Fr	40	60	63	Hz	Tv=Tvd+Tvb
	Frame Rate (Scan & DCR On)	Fr	59	60	61	Hz	
	Total	Tv	(1209)	1235	(1245)	Th	-
	Display	Tvd	1200	1200	1200	Th	-
	Blank	Tvb	Tv-Tvd	35	Tv-Tvd	Th	-
Horizontal Active Display Term	Total	Th	(1030)	1040	(1075)	Tc	Th=Thd+Thb
	Display	Thd	960	960	960	Tc	-
	Blank	Thb	Th-Thd	80	Th-Thd	Tc	-

Note: Because this module is operated by DE only mode, Hsync and Vsync input signals should be set to low logic level or ground. Otherwise, this module would operate abnormally.

INPUT SIGNAL TIMING DIAGRAM

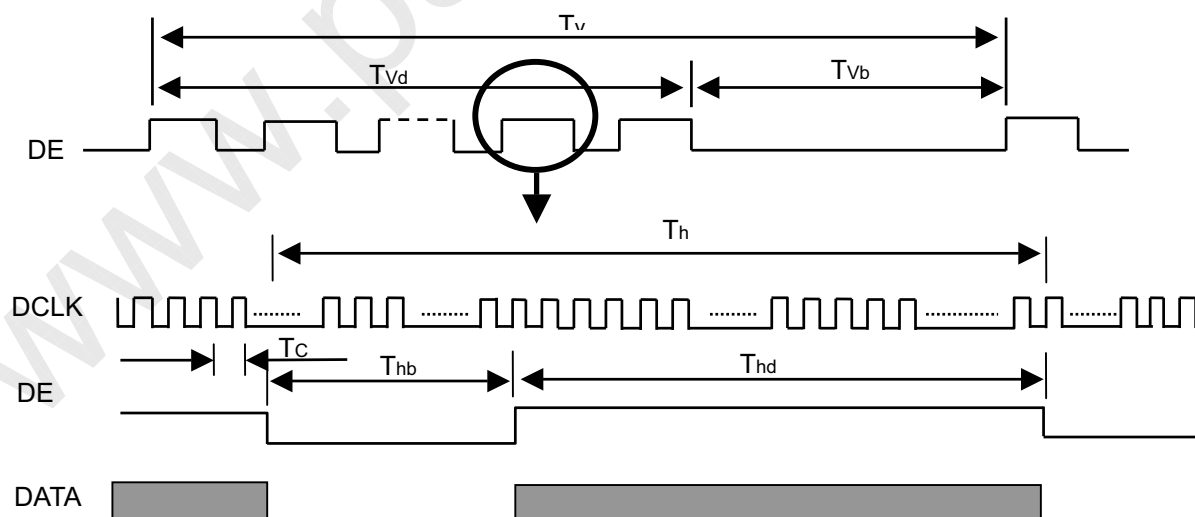

7.2 POWER ON/OFF SEQUENCE

To prevent a latch-up or DC operation of LCD module, the power on/off sequence should be as the diagram below.

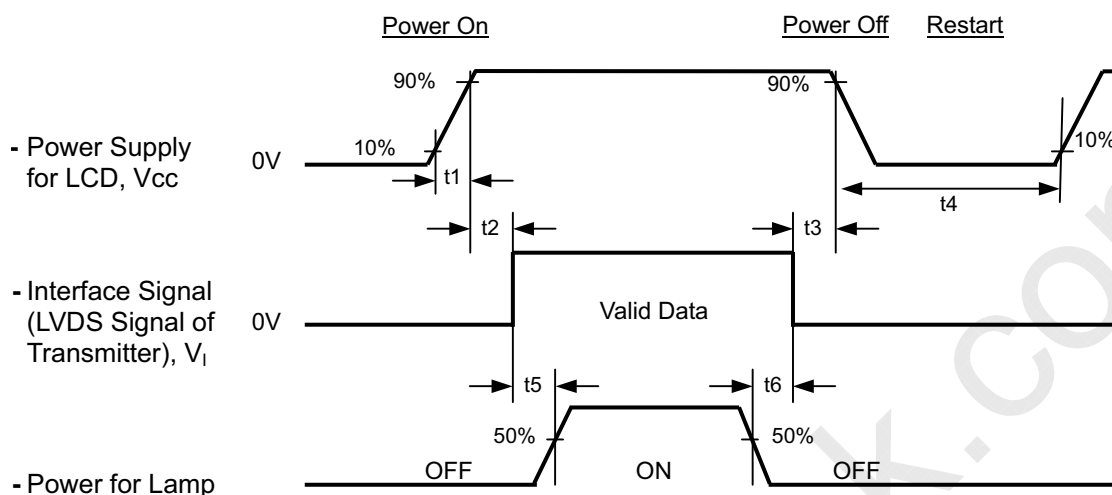

Timing Specifications:

$$0.5 < t_1 \leq 10 \text{ msec}$$

$$0 < t_2 \leq 50 \text{ msec}$$

$$0 < t_3 \leq 50 \text{ msec}$$

$$t_4 \geq 500 \text{ msec}$$

$$t_5 \geq 500 \text{ msec}$$

$$t_6 \geq 90 \text{ msec}$$

7.3 VDD Power DIP Condition

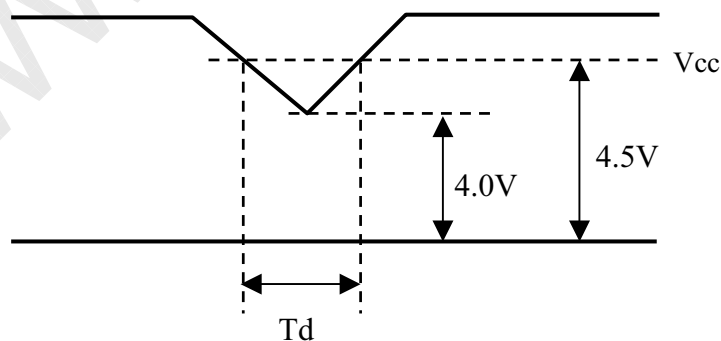

Dip condition: $4.0V \leq V_{cc} \leq 4.5V, T_d \leq 20ms$

8. OPTICAL CHARACTERISTICS

8.1 TEST CONDITIONS

Item	Symbol	Value	Unit
Ambient Temperature	Ta	25±2	°C
Ambient Humidity	Ha	50±10	%RH
Supply Voltage	V _{CC}	5V	V
Input Signal	According to typical value in "3. ELECTRICAL CHARACTERISTICS"		
Lamp Current	I _L	5.0	mA
Inverter Operating Frequency	F _L	58±2	KHz
Inverter	BCM026S01A Rev.04		

8.2 OPTICAL SPECIFICATIONS

The relative measurement methods of optical characteristics are shown in 8.2. The following items should be measured under the test conditions described in 8.1 and stable environment shown in Note (5).

Item	Symbol	Condition	Min.	Typ.	Max.	Unit	Note	
Color Chromaticity (CIE 1931)	Red	R _x	θ _x =0°, θ _y =0° CS1000T	(0.645)	Typ - 0.03 Typ + 0.03	-	(1), (5)	
		R _y		(0.336)				
	Green	G _x		(0.282)				
		G _y		(0.607)				
	Blue	B _x		(0.150)				
		B _y		(0.070)				
	White	W _x		0.313				
		W _y		0.329				
Center Luminance of White (Center of Screen)	Scan Off	L _C	350	500	-	cd/m ²	(4), (5)	
	Scan On		300	400	-			
Contrast Ratio DCR Off	Scan Off	CR	1200	1500	-	-	(2), (5)	
	Scan On		1200	1500	-			
Contrast Ratio DCR On	Scan Off	CR	5000	6000	-	-	(9), (10)	
	Scan On		5000	6000	-			
Response Time	T _R	θ _x =0°, θ _y =0° USB2000	-	15	20	ms	(3), (7)	
	T _F		-	5	10			
	T _{GI_G_AVE_}		-	7	13			
Motion Picture Response Time (For Scan Function On)	T _{MPRT}	θ _x =0°, θ _y =0°	-	12	14	ms	(8)	
White Variation	δW	θ _x =0°, θ _y =0° USB2000	-	1.5	1.6	-	(5), (6)	
Viewing Angle	Horizontal	θ _{x+}	CR ≥ 10 USB2000	80	88	-	Deg.	(1), (5)
		θ _{x-}		80	88	-		
	Vertical	θ _{y+}		80	88	-		
		θ _{y-}		80	88	-		

Note (1) Definition of Viewing Angle (θ_x , θ_y):

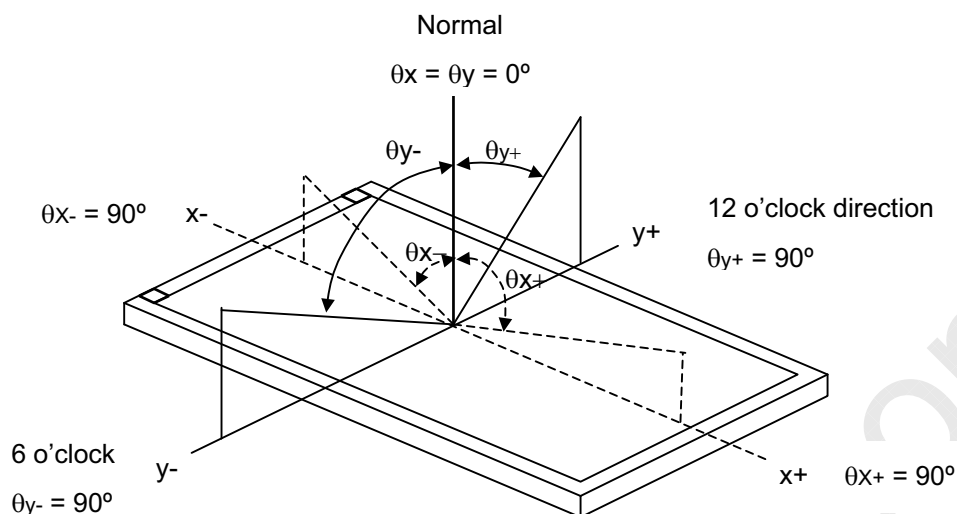

Note (2) Definition of Contrast Ratio (CR):

The contrast ratio can be calculated by the following expression.

$$\text{Contrast Ratio (CR)} = L_{255} / L_0$$

L₂₅₅: Luminance of gray level 255

L₀: Luminance of gray level 0

$$\text{CR} = \text{CR (1)}$$

CR (X) is corresponding to the Contrast Ratio of the point X at Figure in Note (6).

Note (3) Definition of Response Time (T_R , T_F):

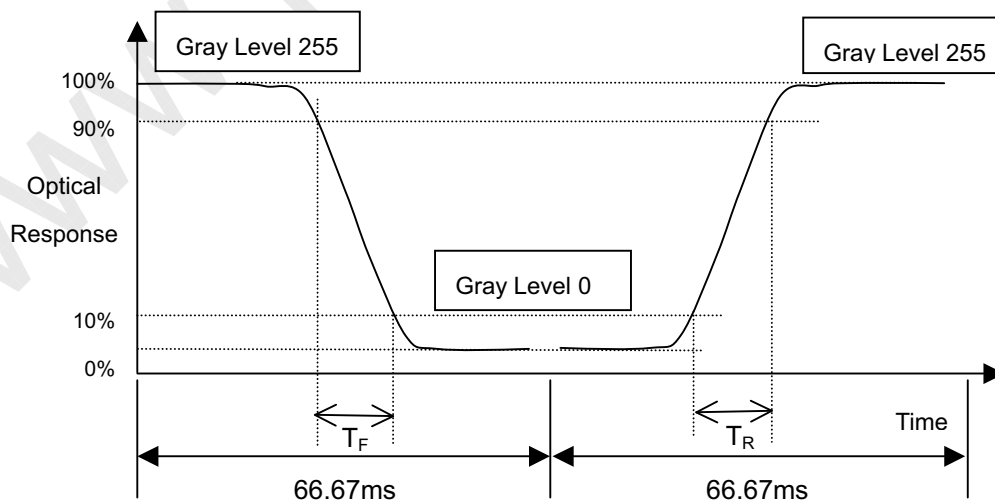

Note (4) Definition of Luminance of White (L_c):

Measure the luminance of gray level 255 at center point

$$L_c = L(1)$$

$L(x)$ is corresponding to the luminance of the point X at Figure in Note (6).

Note (5) Measurement Setup:

The LCD module should be stabilized at given temperature for 60 minutes to avoid abrupt temperature change during measuring. In order to stabilize the luminance, the measurement should be executed after lighting Backlight for 60 minutes in a windless room.

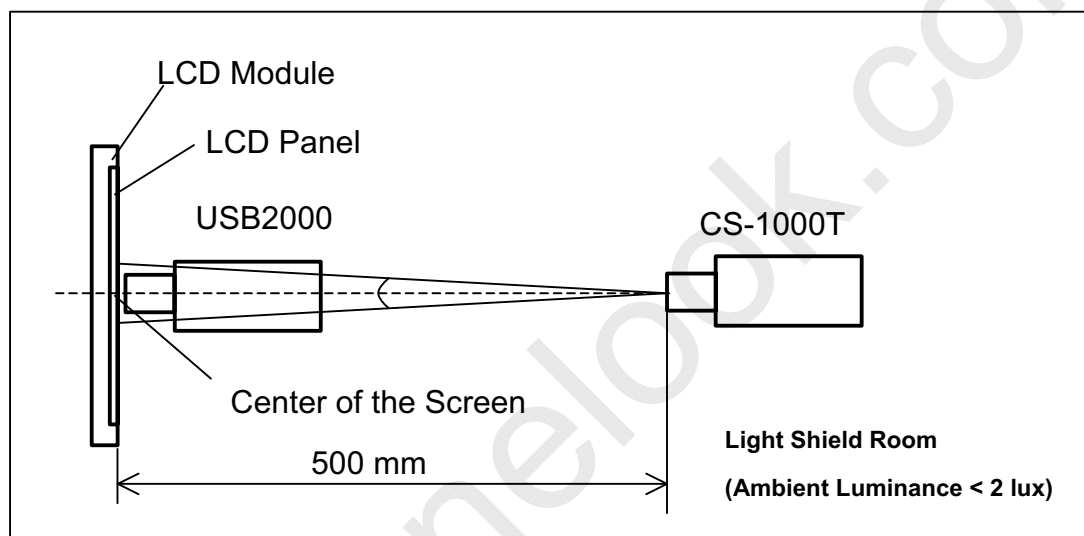

Note (6) Definition of White Variation (δW):

Measure the luminance of gray level 255 at 13 points

$$\delta W = \frac{\text{Maximum [L(1), L(2), L(3), L(4), L(5), L(6), L(7), L(8), L(9), L(10), L(11), L(12), L(13)]}}{\text{Minimum [L(1), L(2), L(3), L(4), L(5), L(6), L(7), L(8), L(9), L(10), L(11), L(12), L(13)]}}$$

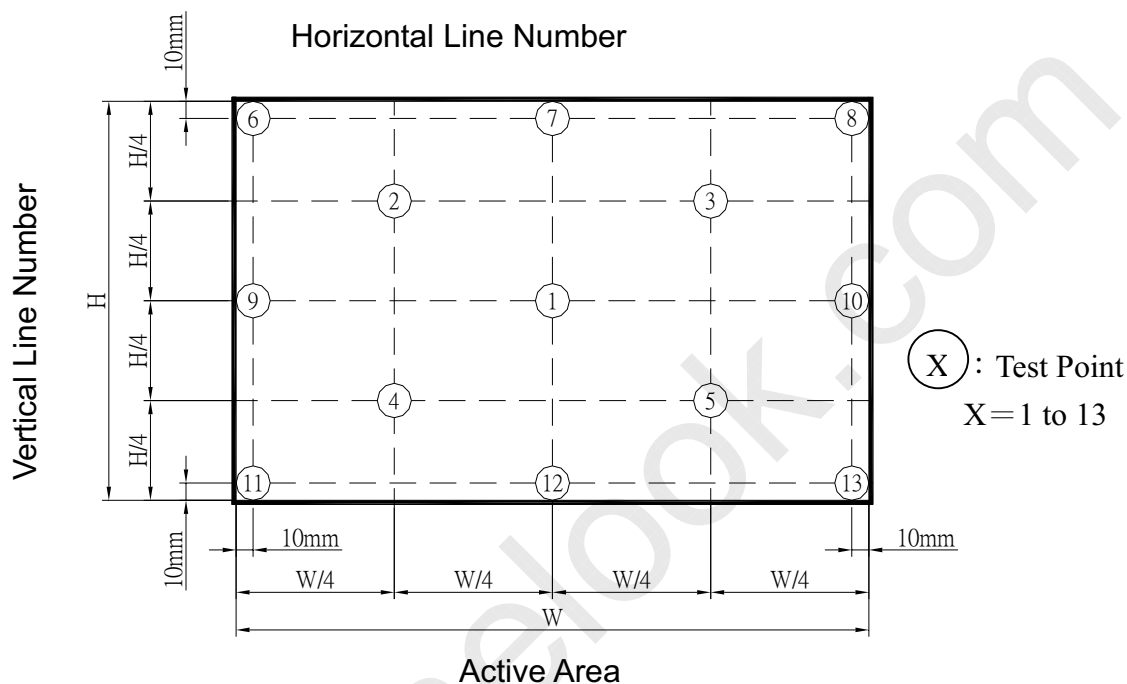

Note (7) Definition of Response Time ($T_{GTG_AVE.}$):

T_{GTG_AVE} is defined as the total average response time for "Gray To Gray".

The Gray to Gray response time is defined as the following chart.

Gray to Gray		Target Gray				
		G000	G063	G127	G191	G255
Initial Gray	G000					
	G063					
	G127					
	G191					
	G255					

Note (8) Definition of MPRT (T_{MPRT}):

Upper center 9×9

The motion picture response time is the average of blurred edge widths divided by scroll speed u (10 pixels per frame):

$$T_{MPRT} = \frac{1}{uNf} \sum_{i \neq j} b_{ij}$$

Where

Bij is 10% to 90% blurred edge width measured by Otsuka MPRT-1000.

F is frame rate.

N is the number of $i \neq j$ transitions. For the case of nine gray levels ($i=0,31,63,91,127,191,223,255$; $j=0,31,63,91,127,223,255$, and $i \neq j$).

Note (9) Contrast Ratio in DCR Function On Measurement Setup:

The LCD module should be stabilized at given temperature for 60 minutes to avoid abrupt temperature change during measuring. After that, in order to stabilize the luminance at dark pattern in the DCR on or SCAN on mode, the measurement should be executed after turn on the DCR or SCAN function for 15 minutes.

Note (10) Definition of Contrast Ratio (CR) in DCR Function:

The contrast ratio can be calculated by the following expression.

$$\text{Contrast Ratio (CR)} = L_{255} / L_0$$

L255: Luminance of gray level 255 after lighting on for 60 minutes

L 0: Luminance of gray level 0 after lighting on for 60 minutes, the measurement should be executed after turn on the DCR or SCAN function for 15 minutes.

$$\text{CR} = \text{CR} (1)$$

CR (X) is corresponding to the Contrast Ratio of the point X at Figure in Note (6).

9. PACKAGING

9.1 PACKING SPECIFICATIONS

- (1) 5 LCD modules / 1 Box
- (2) Box dimensions: 680(L) X 400(W) X 360(H) mm
- (3) Weight: approximately 17.5Kg (5 modules per box)

9.2 PACKING METHOD

- (1) Carton Packing should have no failure in the following reliability test items.

Test Item	Test Conditions	Note
Vibration	ISTA STANDARD Random, Frequency Range: 1 – 200 Hz Top & Bottom: 30 minutes (+Z), 10 min (-Z), Right & Left: 10 minutes (X) Back & Forth 10 minutes (Y)	Non Operation
Dropping Test	1 Angle, 3 Edge, 6 Face, 60cm	Non Operation

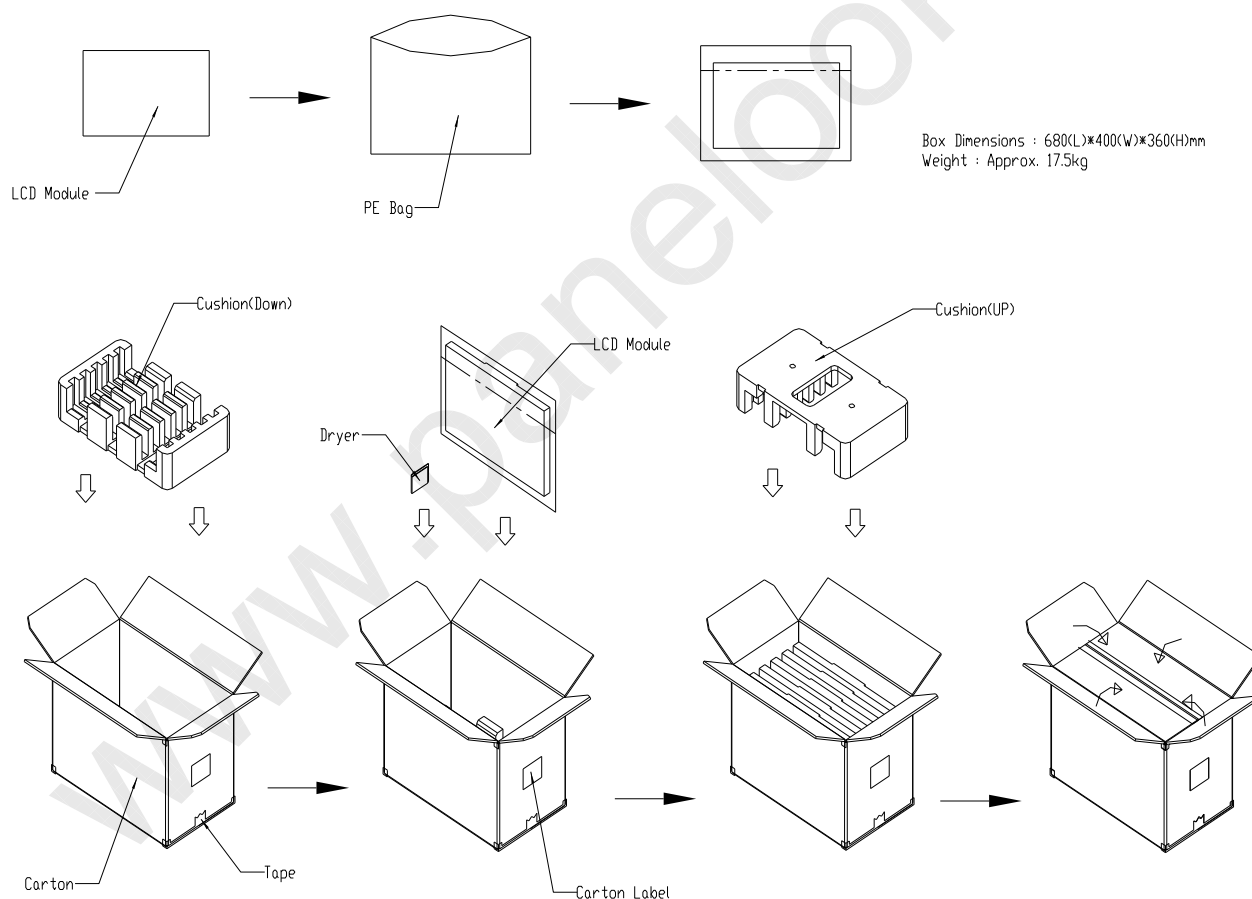
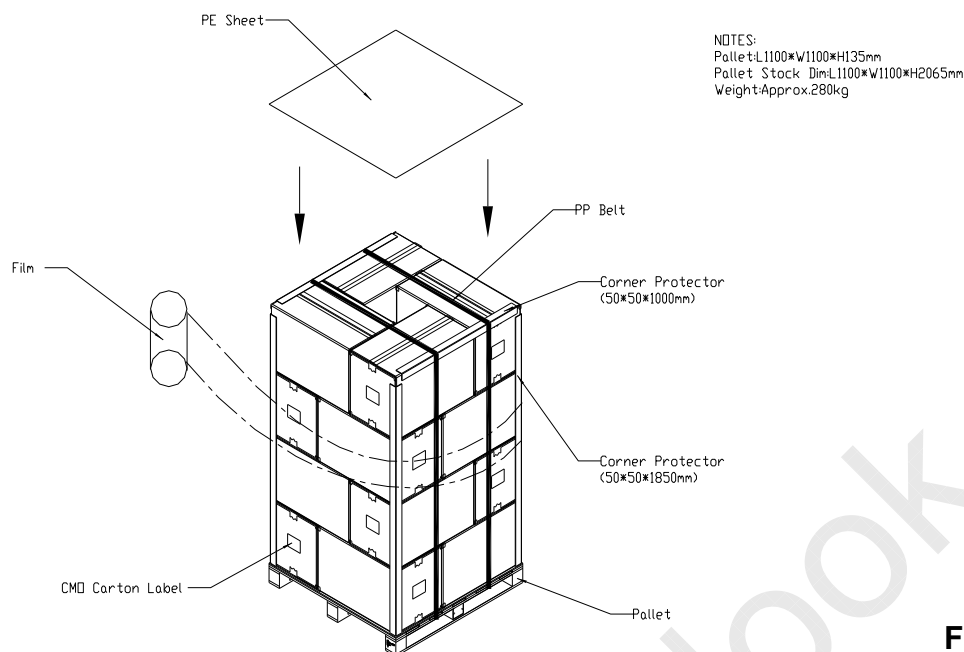
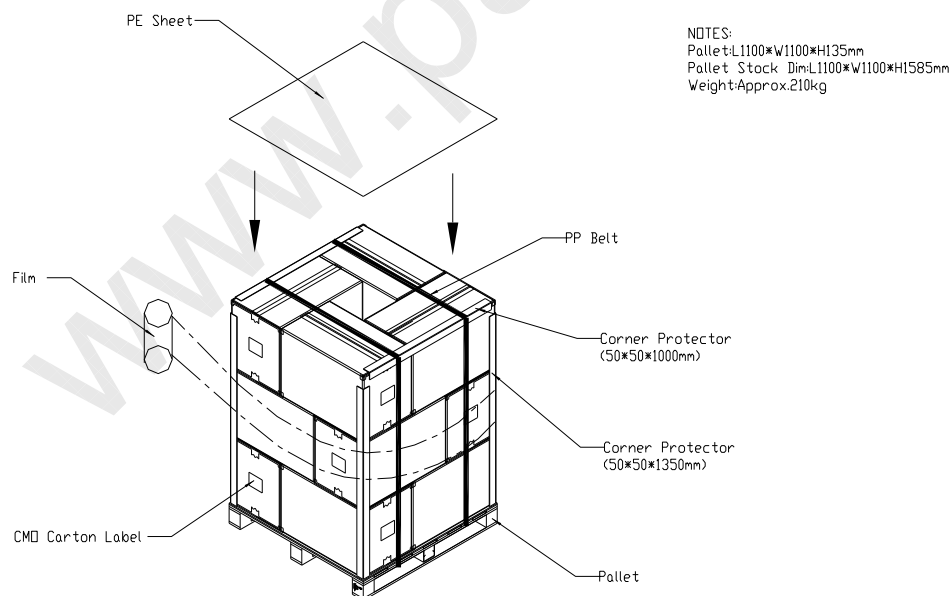

Figure. 8-1 Packing method

For ocean shipping**Figure. 8-2 Packing method****For air transport****Figure. 8-3 Packing method**

10. DEFINITION OF LABELS

10.1 CMO MODULE LABEL

The barcode nameplate is pasted on each module as illustration, and its definitions are as following explanation.

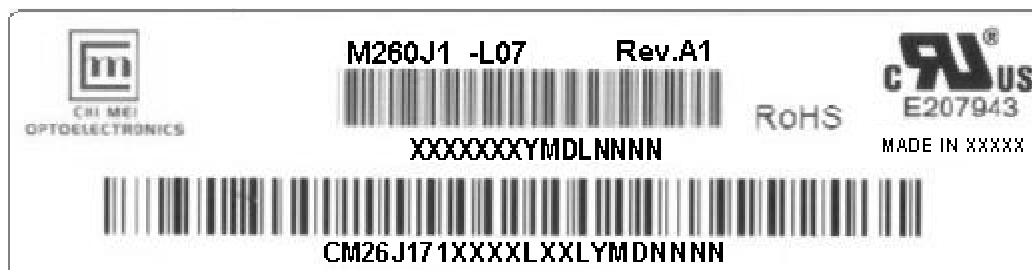

- (a) Model Name: M260J1-L07
 (b) Revision: Rev. XX, for example: A0, A1... B1, B2... or C1, C2...etc.
 (c) CMO barcode definition:

Serial ID: XX-XX-X-XX-YMD-L-NNNN

Code	Meaning	Description
XX	CMO internal use	-
XX	Revision	Cover all the change
X	CMO internal use	-
XX	CMO internal use	-
YMD	Year, month, day	Year: 2001=1, 2002=2, 2003=3, 2004=4... Month: 1~12=1, 2, 3, ~, 9, A, B, C Day: 1~31=1, 2, 3, ~, 9, A, B, C, ~, W, X, Y, exclude I, O, and U.
L	Product line #	Line 1=1, Line 2=2, Line 3=3, ...
NNNN	Serial number	Manufacturing sequence of product

- (d) Customer's barcode definition:

Serial ID: CM-26J17-X-X-X-XX-L-XX-L-YMD-NNNN

Code	Meaning	Description
CM	Supplier code	CMO=CM
26J17	Model number	M260J1-L07 = 26J17
X	Revision code	Non ZBD: 1,~,9,0 / ZBD: A~Z
X	Source driver IC code	Century=1, CLL=2, Demos=3, Epson=4, Fujitsu=5, Himax=6, Hitachi=7, Hynix=8, LDI=9, Matsushita=A, NEC=B, Novatec=C, OKI=D, Philips=E, Renasas=F, Samsung=G, Sanyo=H, Sharp=I, TI=J, Topro=K, Toshiba=L, Windbond=M
X	Gate driver IC code	
XX	Cell location	Tainan Taiwan=TN, Ningbo China=NP
L	Cell line #	1~12=0~C
XX	Module location	Tainan Taiwan=TN, Ningbo China=NP
L	Module line #	1~12=0~C
YMD	Year, month, day	Year: 2001=1, 2002=2, 2003=3, 2004=4... Month: 1~12=1, 2, 3, ~, 9, A, B, C Day: 1~31=1, 2, 3, ~, 9, A, B, C, ~, T, U, V
NNNN	Serial number	By LCD supplier

11. PRECAUTIONS

10.1 ASSEMBLY AND HANDLING PRECAUTIONS

- (1) Do not apply rough force such as bending or twisting to the module during assembly.
- (2) To assemble or install module into user's system can be only in clean working areas. The dust and oil may cause electrical short or worsen the polarizer.
- (3) It's not permitted to have pressure or impulse on the module because the LCD panel and Backlight will be damaged.
- (4) Always follow the correct power sequence when LCD module is connecting and operating. This can prevent damage to the CMOS LSI chips during latch-up.
- (5) Do not pull the I/F connector in or out while the module is operating.
- (6) Do not disassemble the module.
- (7) Use a soft dry cloth without chemicals for cleaning, because the surface of polarizer is very soft and easily scratched.
- (8) It is dangerous that moisture come into or contacted the LCD module, because moisture may damage LCD module when it is operating.
- (9) High temperature or humidity may reduce the performance of module. Please store LCD module within the specified storage conditions.
- (10) When ambient temperature is lower than 10°C may reduce the display quality. For example, the response time will become slowly, and the starting voltage of CCFL will be higher than room temperature.

10.2 SAFETY PRECAUTIONS

- (1) The startup voltage of Backlight is approximately 1000 Volts. It may cause electrical shock while assembling with inverter. Do not disassemble the module or insert anything into the Backlight unit.
- (2) If the liquid crystal material leaks from the panel, it should be kept away from the eyes or mouth. In case of contact with hands, skin or clothes, it has to be washed away thoroughly with soap.
- (3) After the module's end of life, it is not harmful in case of normal operation and storage.

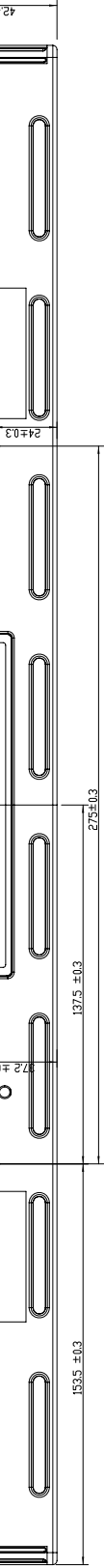

GAP:0.5A

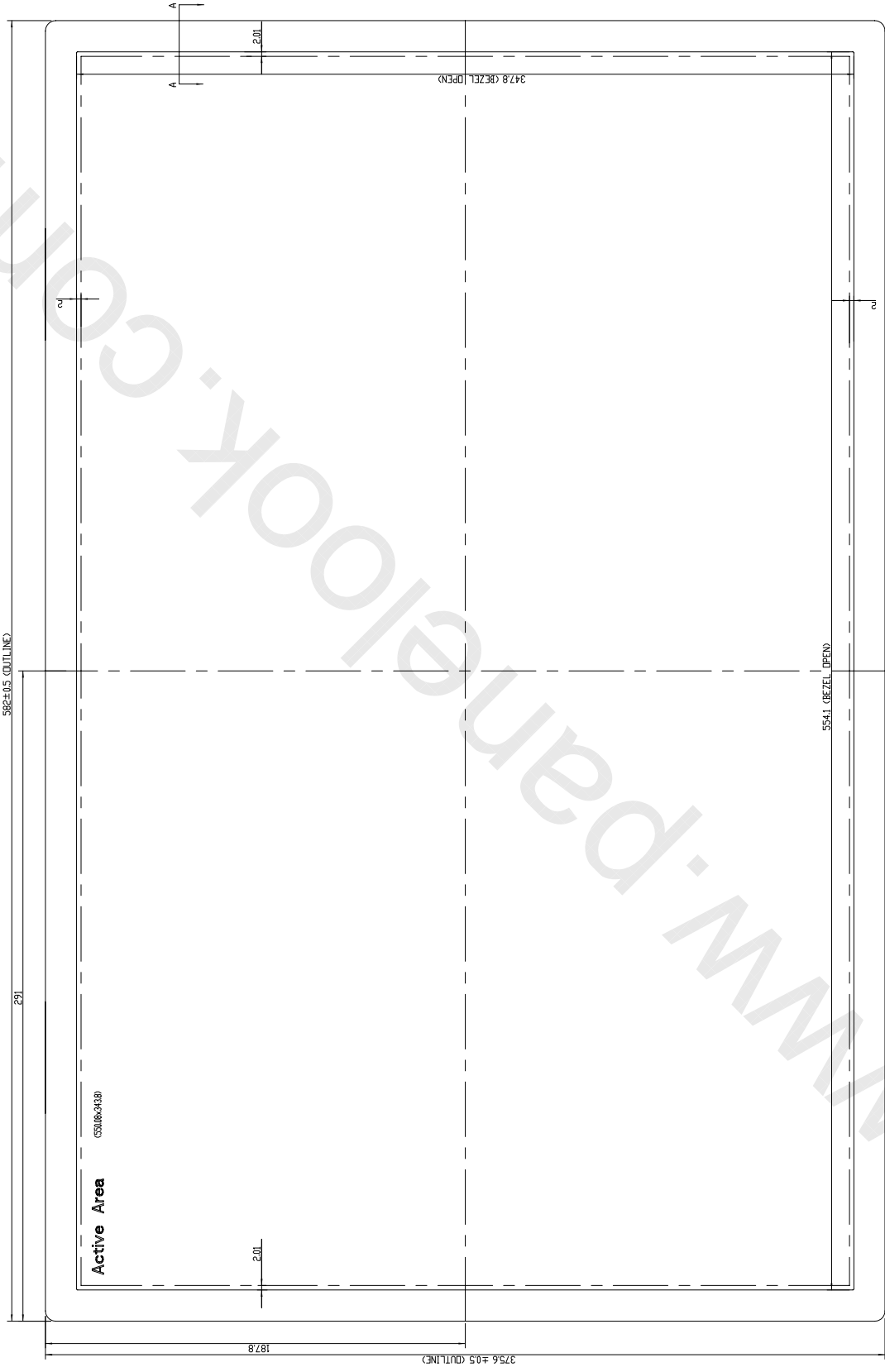

Active Area (5308x438)

2-M3 PITCH 0.5mm USER HOLE
MAX. SREW LENGH 10mm
MAX. SREW TORQUE 0.5N·m

2-M3 PITCH 0.5mm
MAX. SREW LENGH 10mm
MAX. SREW TORQUE 0.5N·m

SCALE 1:1

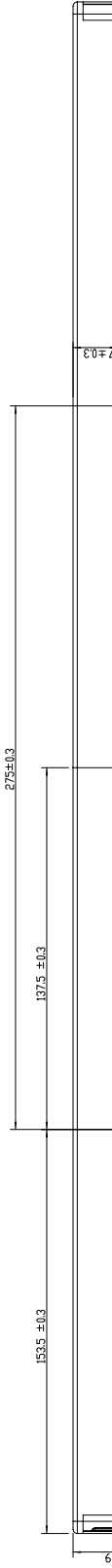

9

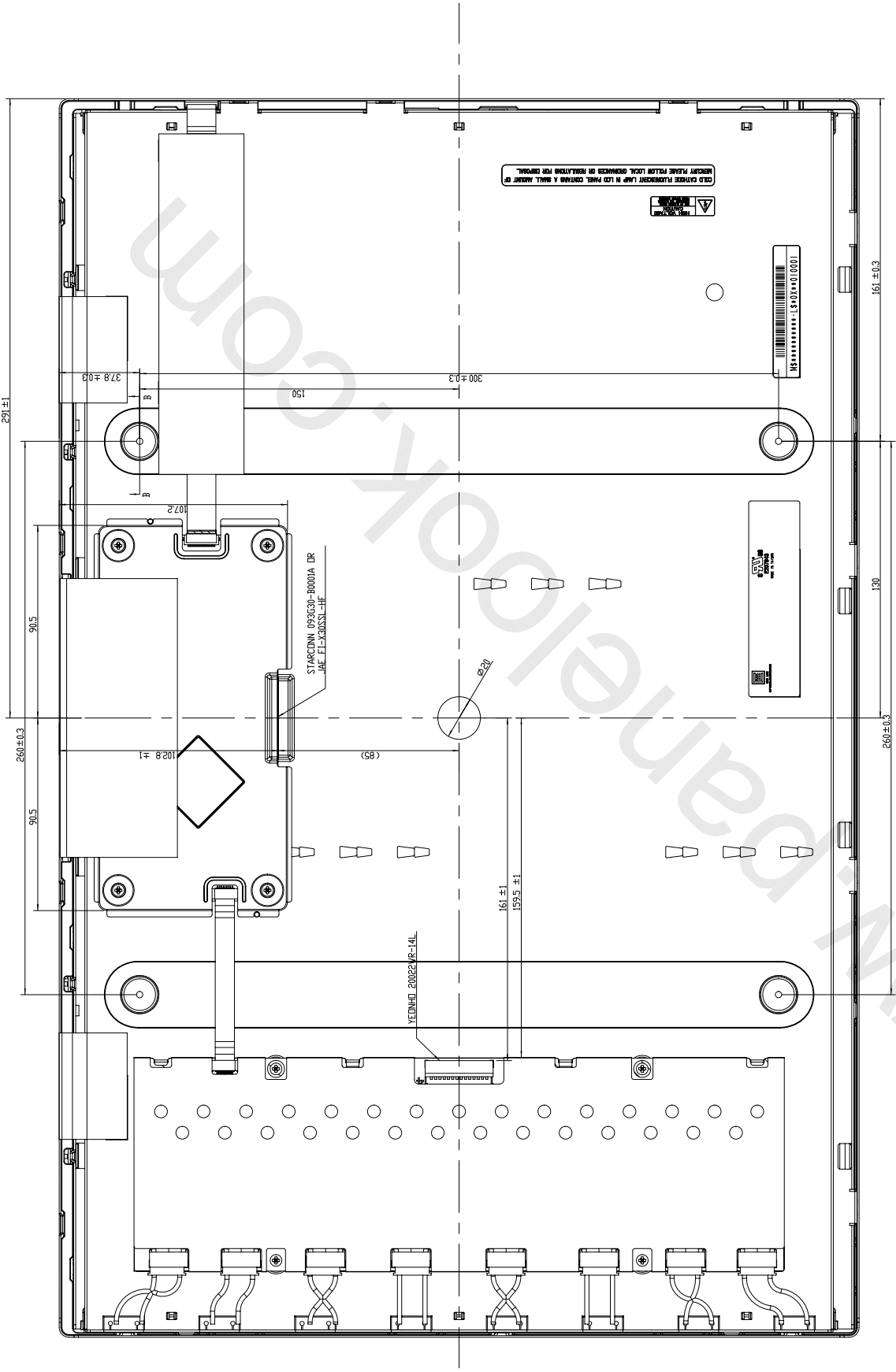

31.9 ± 0.5 (x4)
(User Mounting)

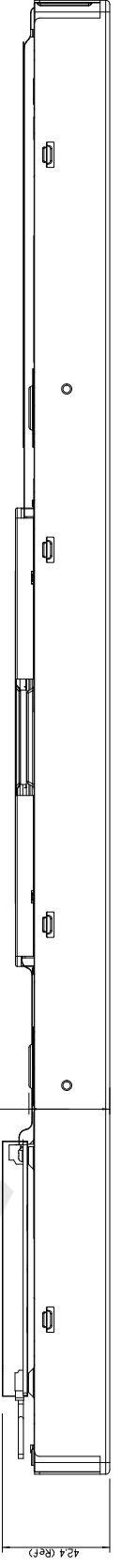

4-H3 PITCH 0.5mm USER HOLE
MAX. SCREW LENGTH 2.5mm
MAX. SCREW TORQUE 0.50kgf-cm

