



# Product Specification

M270DAN01.2

AU OPTRONICS CORPORATION

(V) Preliminary Specification

(V) Final Specification

Module	27.0" Color TFT-LCD
Model Name	M270DAN01.2

<table> <tr> <td><b>Customer</b></td> <td><b>Date</b></td> </tr> <tr> <td>_____</td> <td>_____</td> </tr> </table>	<b>Customer</b>	<b>Date</b>	_____	_____	<table> <tr> <td><b>Approved by</b></td> <td><b>Date</b></td> </tr> <tr> <td><u><b>Howard Lee</b></u></td> <td><u>Jun 19, 2014</u></td> </tr> </table>	<b>Approved by</b>	<b>Date</b>	<u><b>Howard Lee</b></u>	<u>Jun 19, 2014</u>
<b>Customer</b>	<b>Date</b>								
_____	_____								
<b>Approved by</b>	<b>Date</b>								
<u><b>Howard Lee</b></u>	<u>Jun 19, 2014</u>								
<table> <tr> <td><b>Approved by</b></td> <td></td> </tr> <tr> <td>_____</td> <td>_____</td> </tr> </table>	<b>Approved by</b>		_____	_____	<table> <tr> <td><b>Prepared by</b></td> <td><b>Date</b></td> </tr> <tr> <td><u><b>Eric Lee</b></u></td> <td><u>Jun 19, 2014</u></td> </tr> </table>	<b>Prepared by</b>	<b>Date</b>	<u><b>Eric Lee</b></u>	<u>Jun 19, 2014</u>
<b>Approved by</b>									
_____	_____								
<b>Prepared by</b>	<b>Date</b>								
<u><b>Eric Lee</b></u>	<u>Jun 19, 2014</u>								
<p>Note: This Specification is subject to change without notice.</p>		<p>AU Optronics corporation</p>							

For ACMEPOINT Internal Use Only - Provided By lewisjao On 2014/07/11

## Contents

<b>1 Handling Precautions.....</b>	<b>4</b>
<b>2 General Description .....</b>	<b>5</b>
2.1 Display Characteristics.....	5
2.2 Absolute Maximum Rating of Environment .....	6
2.3 Optical Characteristics .....	7
<b>3 TFT-LCD Module.....</b>	<b>12</b>
3.1 Block Diagram.....	12
3.2 Interface Connection.....	13
3.2.1 Connector Type.....	13
3.2.2 Connector Pin Assignment.....	13
3.3.1 Absolute Maximum Rating .....	17
3.3.2 Recommended Operating Condition.....	17
3.4 Signal Characteristics .....	18
3.4.1 LCD Pixel Format.....	18
3.4.2 LVDS Data Format.....	19
3.4.3 Color versus Input Data .....	20
3.4.4 LVDS Specification.....	21
3.4.5 Input Timing Specification .....	23
3.4.6 Input Timing Diagram.....	24
3.5 Power ON/OFF Sequence .....	25
<b>4 Backlight Unit.....</b>	<b>26</b>
4.1 Block Diagram.....	26
4.2 Interface Connection.....	27
4.2.1 Connector Type.....	27
4.2.2 Connector Pin Assignment.....	29
4.3 Electrical Characteristics.....	30
4.3.1 Absolute Maximum Rating .....	30
4.3.2 Recommended Operating Condition.....	30
<b>5 Reliability Test.....</b>	<b>32</b>
<b>6 Shipping Label.....</b>	<b>33</b>
<b>7 Mechanical Characteristics.....</b>	<b>34</b>
<b>8 Packing Specification.....</b>	<b>36</b>
8.1 Packing Flow.....	36
8.2 Pallet and shipment information.....	37

**Record of Revision**

Version	Date	Page	Old description	New Description	Remark
0.1	2014/4/15	All	First version release	-	
0.2	2014/6/20	All	New version of GOA mask release		

SPLCD.com  
Supply & Purchase Cloud Platform



## 1 Handling Precautions

- 1) Since front polarizer is easily damaged, pay attention not to scratch it.
- 2) Be sure to turn off power supply when inserting or disconnecting from input connector.
- 3) Wipe off water drop immediately. Long contact with water may cause discoloration or spots.
- 4) When the panel surface is soiled, wipe it with absorbent cotton or other soft cloth.
- 5) Since the panel is made of glass, it may break or crack if dropped or bumped on hard surface.
- 6) Since CMOS LSI is used in this module, take care of static electricity and insure human earth when handling.
- 7) Do not open or modify the Module Assembly.
- 8) Do not press the reflector sheet at the back of the module to any directions.
- 9) In case a TFT-LCD Module has to be put back into the packing container slot after once it was taken out from the container, do not press the center of the LED lightbar edge. Otherwise the TFT-LCD Module may be damaged.
- 10) Insert or pull out the interface connector, be sure not to rotate nor tilt it of the TFT-LCD Module.
- 11) Do not twist nor bend the TFT -LCD Module even momentary. It should be taken into consideration that no bending/twisting forces are applied to the TFT-LCD Module from outside. Otherwise the TFT-LCD Module may be damaged.
- 12) Please avoid touching COF position while you are doing mechanical design.
- 13) When storing modules as spares for a long time, the following precaution is necessary: Store them in a dark place. Do not expose the module to sunlight or fluorescent light. Keep the temperature between 5°C and 35°C at normal humidity.





## 2 General Description

This specification applies to the 27.0 inch wide Color a-Si TFT-LCD Module M270DAN01.2. The display supports the WQHD - 2560(H) x 1440(V) screen format and 1.07B colors (10bits RGB data input). The input interface is 4 port LVDS and this module doesn't contain an driver board for backlight.

### 2.1 Display Characteristics

The following items are characteristics summary on the table under 25°C condition.

ITEMS	Unit	SPECIFICATIONS
Screen Diagonal	[mm]	684.7 (27.0")
Active Area	[mm]	596.74 (H) x 335.66 (V)
Pixels H x V	-	2560(x3) x 1440
Pixel Pitch	[um]	233.1 (per one triad) ×233.1
Pixel Arrangement	-	R.G.B. Vertical Stripe
Display Mode	-	Normally Black
White Luminance ( Center )	[cd/m <sup>2</sup> ]	350 cd/m <sup>2</sup> (Typ.)
Contrast Ratio	-	1000 (Typ.)
Response Time	[msec]	12ms (Typ., G/G)
Power Consumption (LCD Module + Backligh unit)	[Watt]	28.7W (Typ.) LCD module : PDD (Typ.)=5.5 W @ white pattern,Fv=60Hz Backlight unit : P <sub>BLU</sub> (Typ.) =23.2W @ I <sub>RLED</sub> =110mA
Weight	[Grams]	3480g
Outline Dimension	[mm]	613.9 (H)X357.5(V) x 13.1(D) Typ
Electrical Interface	-	4 channel LVDS (10bits RGB data input)
Support Color	-	1.07B colors
Surface Treatment	-	Anti-Glare, 3H
Temperature Range Operating Storage (Shipping)	[°C] [°C]	0 to +50 -20 to +60
RoHS Compliance	-	RoHS Compliance
TCO Compliance	-	TCO 6.0 Compliance

## 2.2 Absolute Maximum Rating of Environment

Permanent damage may occur if exceeding the following maximum rating.

Symbol	Description	Min.	Max.	Unit	Remark
TOP	Operating Temperature	0	+50	[°C]	<b>Note 2-1</b>
TGS	Glass surface temperature (operation)	0	+65	[°C]	<b>Note 2-1</b> Function judged only
HOP	Operation Humidity	5	90	[%RH]	<b>Note 2-1</b>
TST	Storage Temperature	-20	+60	[°C]	
HST	Storage Humidity	5	90	[%RH]	

**Note 2-1:** Temperature and relative humidity range are shown as the below figure.

1. 90% RH Max (  $T_a \leq 39^\circ\text{C}$  )
2. Max wet-bulb temperature at  $39^\circ\text{C}$  or less. (  $T_a \leq 39^\circ\text{C}$  )
3. No condensation

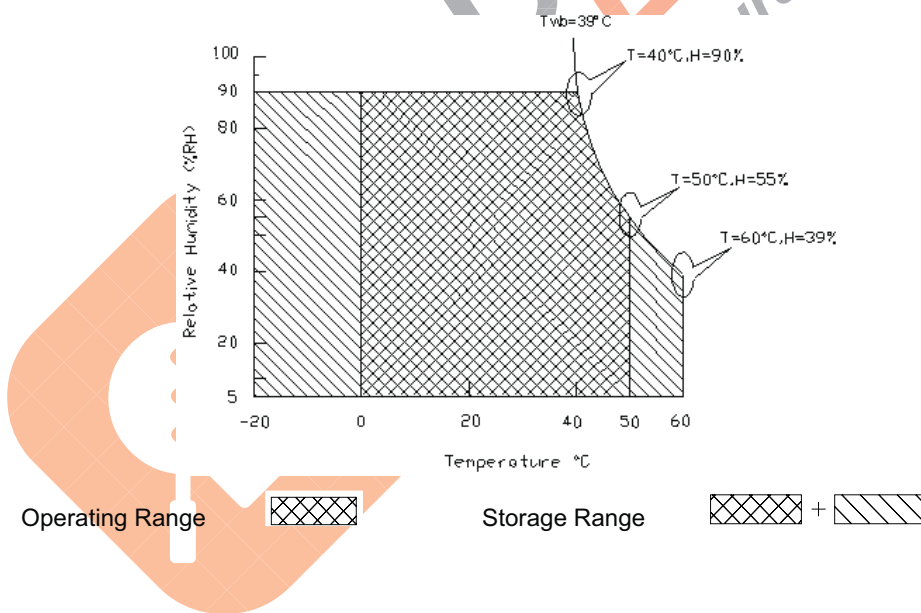

## 2.3 Optical Characteristics

The optical characteristics are measured on the following test condition.

### Test Condition:

1. Equipment setup: Please refer to **Note 2-2**.
2. Panel Lighting time: 30 minutes
3. VDD=5.0V, Fv=60Hz, Is=110mA, Ta=25°C

Symbol	Description		Min.	Typ.	Max.	Unit	Remark
L <sub>w</sub>	White Luminance (Center of screen)		280	350	-	[cd/m <sup>2</sup> ]	<b>Note 2-2</b> By SR-3
L <sub>uni</sub>	Luminance Uniformity (9 points)		75	80	-	[%]	<b>Note 2-3</b> By SR-3
CR	Contrast Ratio (Center of screen)		600	1000	-	-	<b>Note 2-4</b> By SR-3
θ <sub>R</sub>	Horizontal Viewing Angle (CR=10)	Right	75	89	-	[degree]	<b>Note 2-5</b> By SR-3
θ <sub>L</sub>		Left	75	89	-		
Φ <sub>H</sub>	Vertical Viewing Angle (CR=10)	Up	75	89	-		
Φ <sub>L</sub>		Down	75	89	-		
θ <sub>R</sub>	Horizontal Viewing Angle (CR=5)	Right	75	89	-		
θ <sub>L</sub>		Left	75	89	-		
Φ <sub>H</sub>	Vertical Viewing Angle (CR=5)	Up	75	89	-		
Φ <sub>L</sub>		Down	75	89	-		
-	Response Time	Gray to Gray	-	12	-	[msec]	<b>Note 2-6</b> By TRD-100
R <sub>x</sub>	Color Coordinates (CIE 1931)	Red x	0.630	0.660	0.690	-	By SR-3
R <sub>y</sub>		Red y	0.302	0.332	0.362		
G <sub>x</sub>		Green x	0.270	0.300	0.330		
G <sub>y</sub>		Green y	0.599	0.629	0.659		
B <sub>x</sub>		Blue x	0.117	0.147	0.177		
B <sub>y</sub>		Blue y	0.022	0.052	0.082		
W <sub>x</sub>		White x	0.283	0.313	0.343		
W <sub>y</sub>		White y	0.299	0.329	0.359		
sRGB coverage ratio				100	-	[%]	By SR-3
CT	Crosstalk		-	-	1.5	-	<b>Note 2-7</b> By SR-3
F <sub>dB</sub>	Flicker (Center of screen)		-	-	-20	[dB]	<b>Note 2-8</b> By SR-3

**Note 2-2:** Equipment setup :

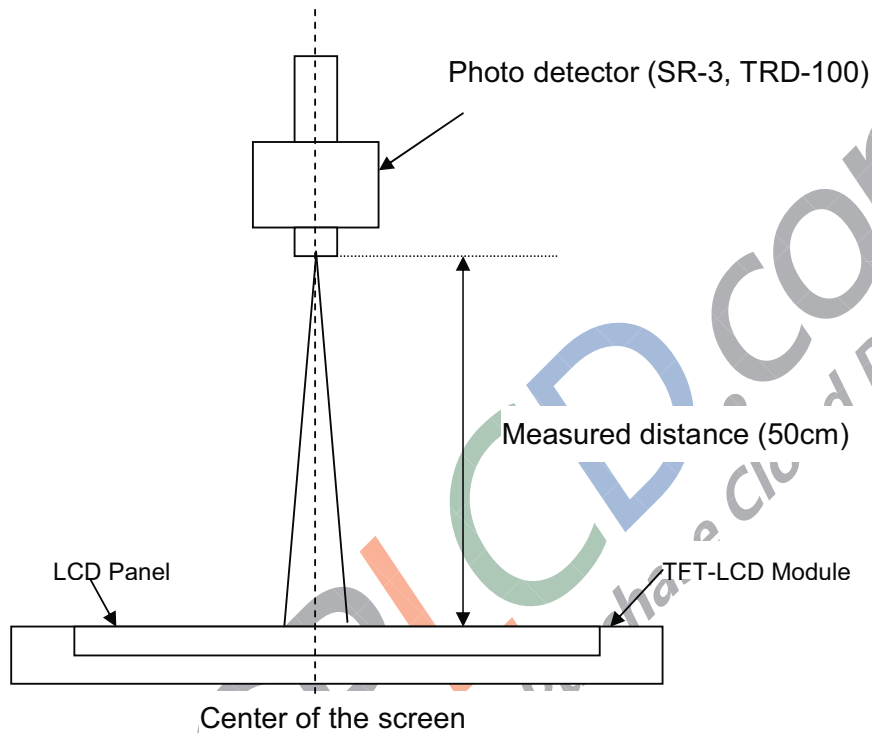

**Note 2-3:** Luminance Uniformity Measurement

**Definition:**

$$\text{Luminance Uniformity} = \frac{\text{Minimum Luminance of 9 Points (P1 ~ P9)}}{\text{Maximum Luminance of 9 Points (P1 ~ P9)}}$$

*a. Test pattern: White Pattern*



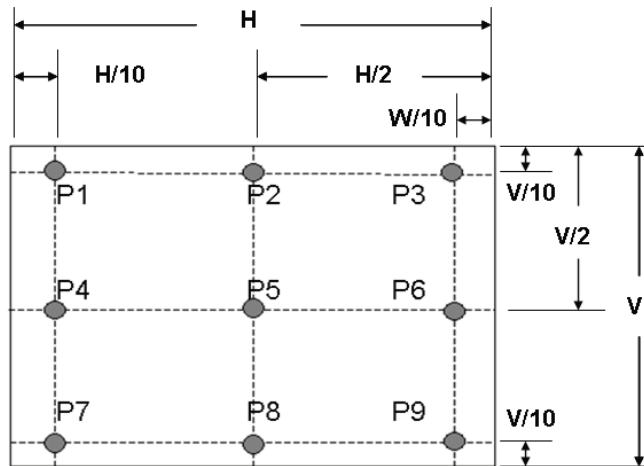

**Note 2-4:** Contrast Ratio Measurement

**Definition:**

$$\text{Contrast Ratio} = \frac{\text{Luminance of White pattern}}{\text{Luminance of Black pattern}}$$

- a. Measured position: Center of screen (P5) & perpendicular to the screen ( $\theta = \Phi = 0^\circ$ )

**Note 2-5:** Viewing angle measurement

**Definition:** The angle at which the contrast ratio is greater than 10 & 5 .

- a. Horizontal view angle: Divide to left & right ( $\theta_L$  &  $\theta_R$ )  
Vertical view angle: Divide to up & down ( $\Phi_H$  &  $\Phi_L$ )

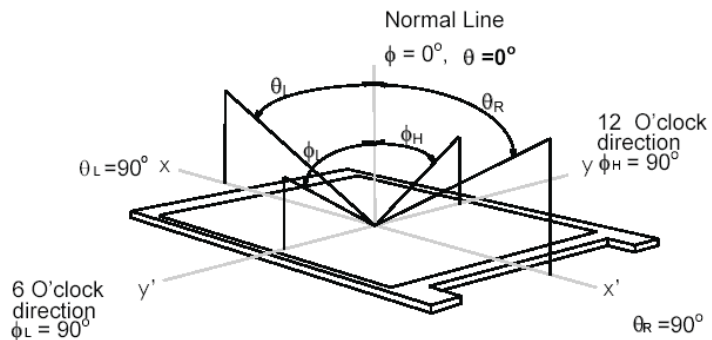

**Note 2-6:** Response time measurement

The output signals of photo detector are measured when the input signals are changed from “Black” to “White” (rising time,  $T_R$ ), and from “White” to “Black” (falling time,  $T_F$ ), respectively. The response time is interval between the 10% and 90% of optical response. (*Black & White color definition: Please refer section*

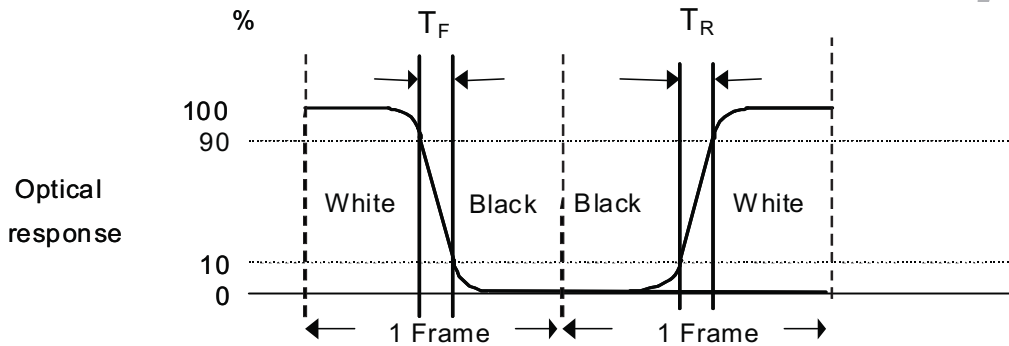

The gray to gray response time is defined as the following table. The algorithm is  $| \text{Gray Level A} - \text{Gray Level B} | \geq 256$ .

Gray Level to Gray Level		Falling Time				
		G0	G255	G511	G767	G1023
Rising Time	G0					
	G255					
	G511					
	G767					
	G1023					

- $T_{GTG\_typ}$  is the total average time at rising time and falling time of gray to gray.
- $T_{GTG\_max}$  is the maximum time at rising time or falling time of gray to gray.

**Note 2-7:** Crosstalk measurement

**Definition:**

$$CT = \text{Max.} (CT_H, CT_V);$$

Where

a. Maximum Horizontal Crosstalk :

$$CT_H = \text{Max.} (| Y_{BL} - Y_{AL} | / Y_{AL} \times 100 \%, | Y_{BR} - Y_{AR} | / Y_{AR} \times 100 \%);$$

Maximum Vertical Crosstalk:

$$CT_V = \text{Max.} (| Y_{BU} - Y_{AU} | / Y_{AU} \times 100 \%, | Y_{BD} - Y_{AD} | / Y_{AD} \times 100 \%);$$

b.  $Y_{AU}, Y_{AD}, Y_{AL}, Y_{AR}$  = Luminance of measured location without Black pattern

$Y_{BU}, Y_{BD}, Y_{BL}, Y_{BR}$  = Luminance of measured location with Black pattern

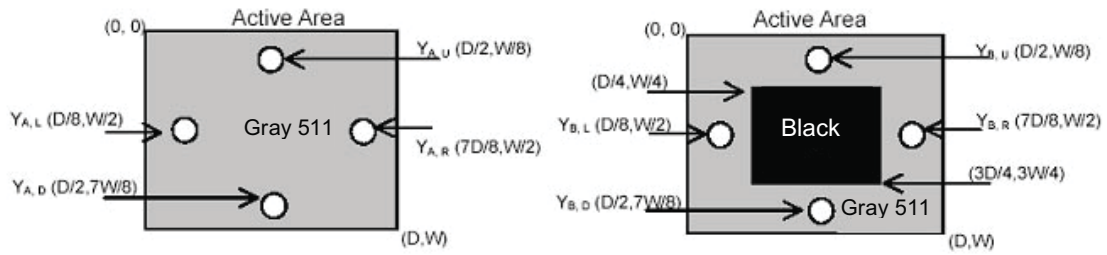

**Note 2-8:** Flicker measurement

a. Test pattern: It is listed as following.

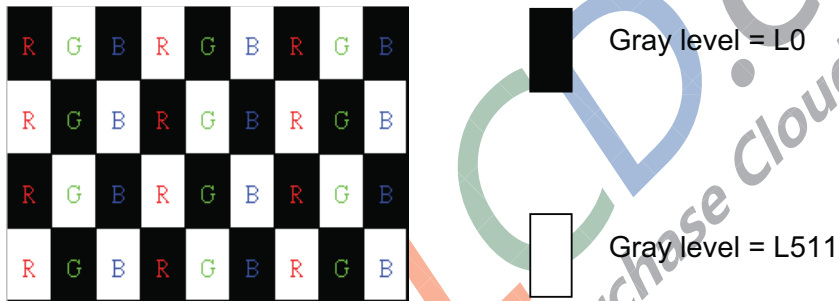

R: Red, G: Green, B:Blue

b. Measured position: Center of screen (P5) & perpendicular to the screen ( $\theta = \phi = 0^\circ$ )



## 3 TFT-LCD Module

### 3.1 Block Diagram

The following shows the block diagram of the 27.0 inch Color TFT-LCD Module.

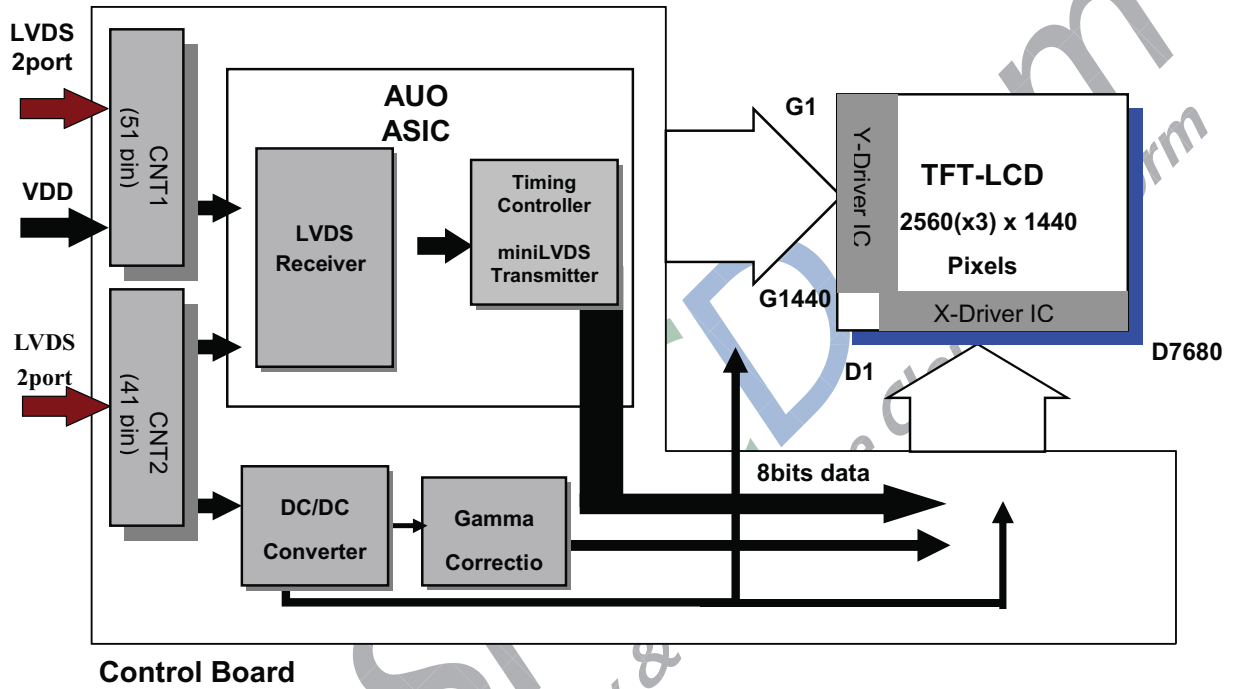



## 3.2 Interface Connection

### 3.2.1 Connector Type

TFT-LCD Connector (CNT1)	Manufacturer	JAE	P-TWO
	Part Number	FI-RE51S-HF	187059-5122
TFT-LCD Connector (CNT2)	Manufacturer	JAE	P-TWO
	Part Number	FI-RE41S-HF	187060-4122
Mating Connector (CNT1)	Manufacturer	JAE	
	Part Number	FI-RE51HL	
Mating Connector (CNT2)	Manufacturer	JAE	
	Part Number	FI-RE41HL	

### 3.2.2 Connector Pin Assignment

#### LVDS CN1

PIN #	Symbol	Description	Remark
1	NC	No Connection (for AUO test only. Do not connect)	
2	NC	No Connection (for AUO test only. Do not connect)	
3	NC	No Connection (for AUO test only. Do not connect)	
4	NC	No Connection (for AUO test only. Do not connect)	
5	NC	No Connection (for AUO test only. Do not connect)	
6	NC	No Connection (for AUO test only. Do not connect)	
7	NC	No Connection (for AUO test only. Do not connect)	
8	NC	No Connection (for AUO test only. Do not connect)	
9	NC	No Connection (for AUO test only. Do not connect)	
10	NC	No Connection (for AUO test only. Do not connect)	
11	GND	Power Ground	
12	R1_0N	FIRST_ Negative LVDS differential data input	
13	R1_0P	FIRST_ Positive LVDS differential data input	
14	R1_1N	FIRST_ Negative LVDS differential data input	
15	R1_1P	FIRST_ Positive LVDS differential data input	
16	R1_2N	FIRST_ Negative LVDS differential data input	
17	R1_2P	FIRST_ Positive LVDS differential data input	
18	GND	Power Ground	



19	R1_CLKN	FIRST_ Negative LVDS differential clock input	
20	R1_CLKP	FIRST_ Positive LVDS differential clock input	
21	GND	Power Ground	
22	R1_3N	FIRST_ Negative LVDS differential data input	
23	R1_3P	FIRST_ Positive LVDS differential data input	
24	R1_4N	FIRST_ Negative LVDS differential data input	
25	R1_4P	FIRST_ Positive LVDS differential data input	
26	GND	Power Ground	
27	GND	Power Ground	
28	R2_0N	SECOND_ Negative LVDS differential data input	
29	R2_0P	SECOND_ Positive LVDS differential data input	
30	R2_1N	SECOND_ Negative LVDS differential data input	
31	R2_1P	SECOND_ Positive LVDS differential data input	
32	R2_2N	SECOND_ Negative LVDS differential data input	
33	R2_2P	SECOND_ Positive LVDS differential data input	
34	GND	Power Ground	
35	R2_CLKN	SECOND_ Negative LVDS differential clock input	
36	R2_CLKP	SECOND_ Positive LVDS differential clock input	
37	GND	Power Ground	
38	R2_3N	SECOND_ Negative LVDS differential data input	
39	R2_3P	SECOND_ Positive LVDS differential data input	
40	R2_4N	SECOND_ Negative LVDS differential data input	
41	R2_4P	SECOND_ Positive LVDS differential data input	
42	GND	Power Ground	
43	GND	Power Ground	
44	GND	Power Ground	
45	NC	No Connection (for AUO test only. Do not connect)	
46	VDD	Power +5V	
47	VDD	Power +5V	
48	VDD	Power +5V	
49	VDD	Power +5V	
50	VDD	Power +5V	
51	VDD	Power +5V	

### LVDS CN2

PIN #	Symbol	Description	Remark
1	NC	No Connection (for AUO test only. Do not connect)	



2	NC	No Connection (for AUO test only. Do not connect)	
3	NC	No Connection (for AUO test only. Do not connect)	
4	NC	No Connection (for AUO test only. Do not connect)	
5	NC	No Connection (for AUO test only. Do not connect)	
6	NC	No Connection (for AUO test only. Do not connect)	
7	NC	No Connection (for AUO test only. Do not connect)	
8	NC	No Connection (for AUO test only. Do not connect)	
9	GND	Power Ground	
10	R3_0N	THIRD_ Negative LVDS differential data input	
11	R3_0P	THIRD_ Positive LVDS differential data input	
12	R3_1N	THIRD_ Negative LVDS differential data input	
13	R3_1P	THIRD_ Positive LVDS differential data input	
14	R3_2N	THIRD_ Negative LVDS differential data input	
15	R3_2P	THIRD_ Positive LVDS differential data input	
16	GND	Power Ground	
17	R3_CLKN	THIRD_ Negative LVDS differential clock input	
18	R3_CLKP	THIRD_ Positive LVDS differential clock input	
19	GND	Power Ground	
20	R3_3N	THIRD_ Negative LVDS differential data input	
21	R3_3P	THIRD_ Positive LVDS differential data input	
22	R3_4N	THIRD_ Negative LVDS differential data input	
23	R3_4P	THIRD_ Positive LVDS differential data input	
24	GND	Power Ground	
25	GND	Power Ground	
26	R4_0N	FOURTH_ Negative LVDS differential data input	
27	R4_0P	FOURTH_ Positive LVDS differential data input	
28	R4_1N	FOURTH_ Negative LVDS differential data input	
29	R4_1P	FOURTH_ Positive LVDS differential data input	
30	R4_2N	FOURTH_ Negative LVDS differential data input	

31	R4_2P	FOURTH_ Positive LVDS differential data input	
32	GND	Power Ground	
33	R4_CLKN	FOURTH_ Negative LVDS differential clock input	
34	R4_CLKP	FOURTH_ Positive LVDS differential clock input	
35	GND	Power Ground	
36	R4_3N	FOURTH_ Negative LVDS differential data input	
37	R4_3P	FOURTH_ Positive LVDS differential data input	
38	R4_4N	FOURTH_ Negative LVDS differential data input	
39	R4_4P	FOURTH_ Positive LVDS differential data input	
40	GND	Power Ground	
41	GND	Power Ground	

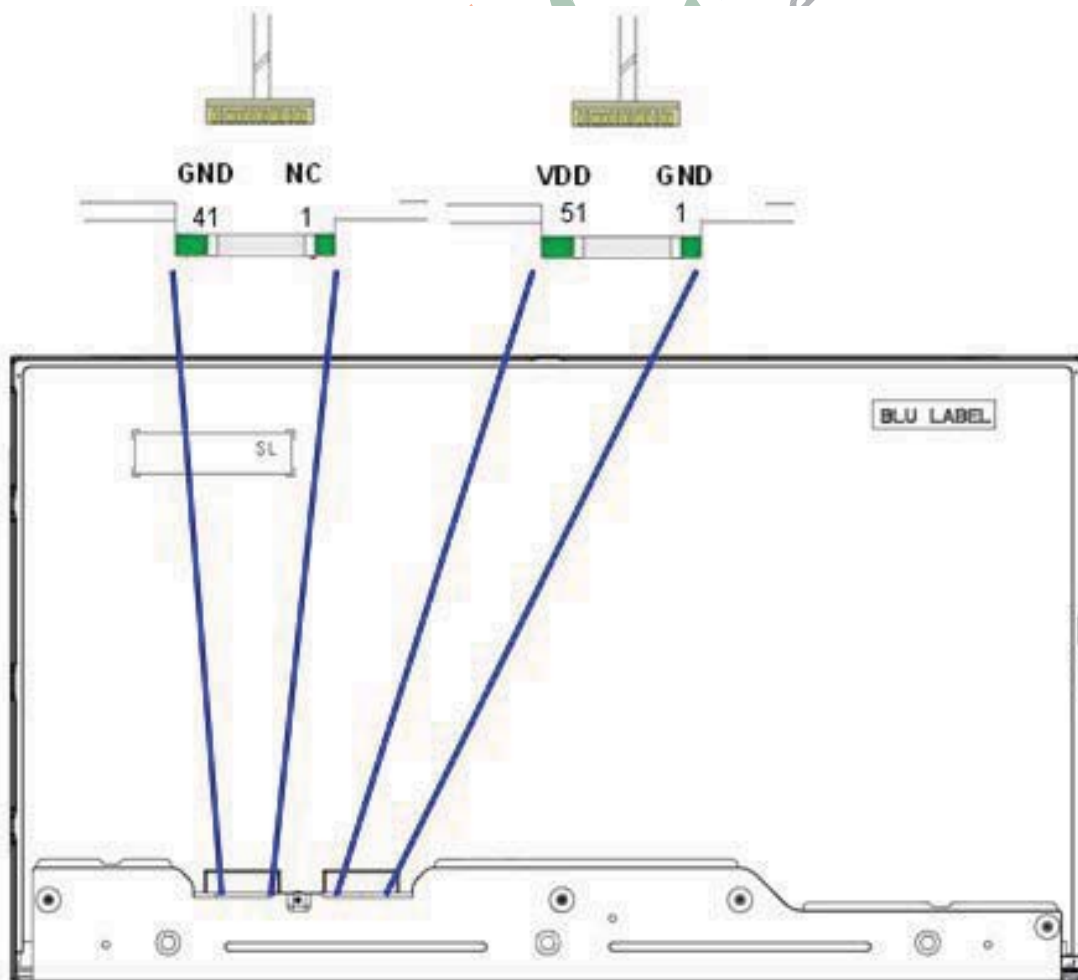



### 3.3 Electrical Characteristics

#### 3.3.1 Absolute Maximum Rating

Permanent damage may occur if exceeding the following maximum rating.

Symbol	Description	Min	Max	Unit	Remark
VDD	Power Supply Input Voltage	GND-0.3	6.0	[Volt]	Ta=25°C

#### 3.3.2 Recommended Operating Condition

Symbol	Description	Min	Typ	Max	Unit	Remark
VDD	Power supply Input voltage	4.5	5.0	5.5	[Volt]	
IDD	Power supply Input Current (RMS)	-	1.1	1.32	[A]	VDD= 5.0V, White Pattern, Fv=60Hz
		-	1.3	1.56	[A]	VDD= 5.0V, White Pattern, Fv=75Hz
PDD	VDD Power Consumption	-	5.5	6.6	[Watt]	VDD= 5.0V, White Pattern, Fv=60Hz
		-	6.5	7.8	[Watt]	VDD= 5.0V, White Pattern, Fv=75Hz
IRush	Inrush Current	-	-	5.0	[A]	<b>Note 3-1</b>
VDDrp	Allowable VDD Ripple Voltage	-	-	500	[mV]	VDD= 5.0V, White Pattern, Fv=75Hz

**Note 3-1:** Inrush Current measurement:

Test circuit:

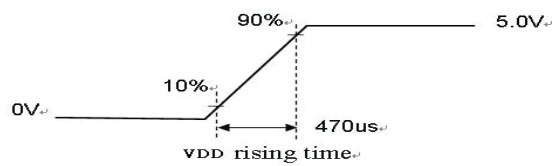
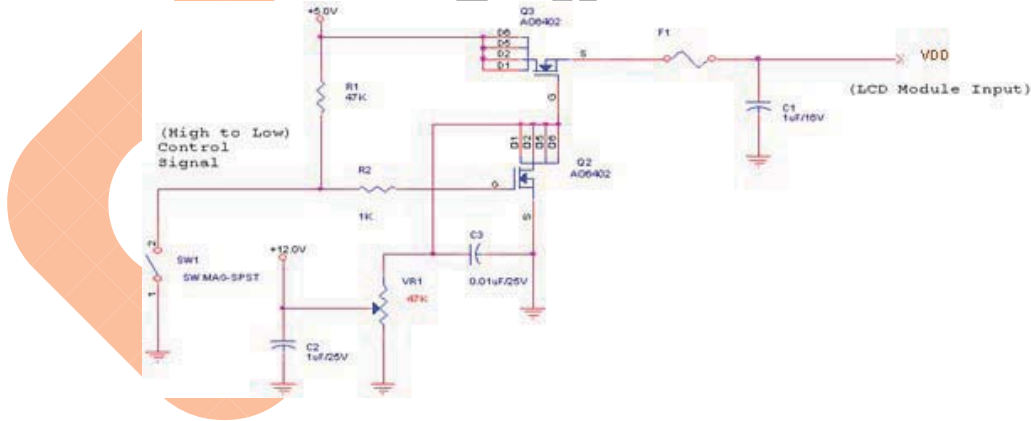

The duration of VDD rising time: 470us.

## 3.4 Signal Characteristics

### 3.4.1 LCD Pixel Format

Following figure shows the relationship between the input signals and LCD pixel format.

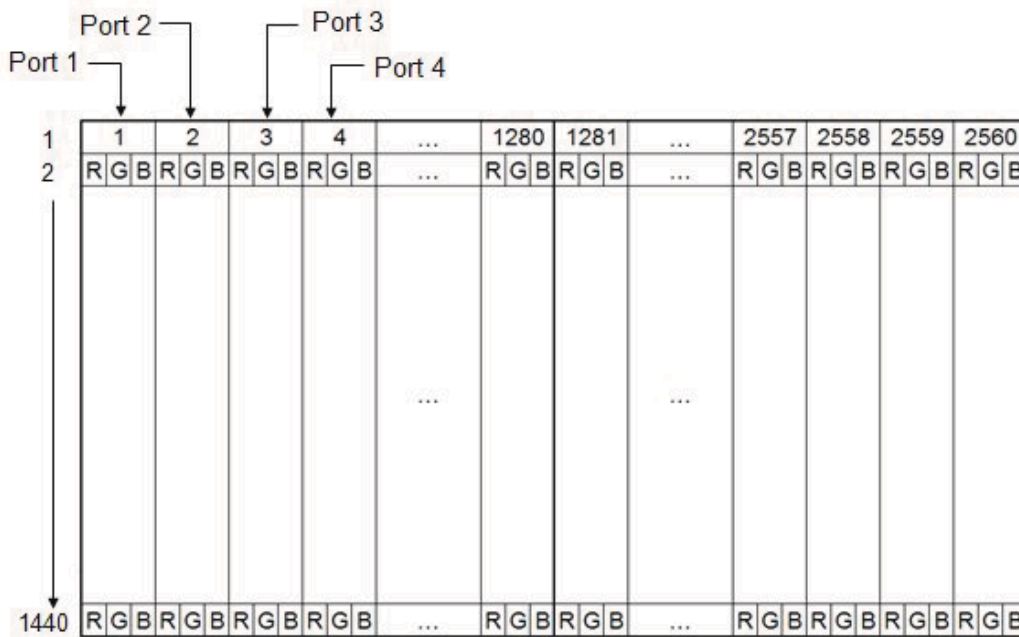

**Note 1:** The module use 4port-LVDS interface.

Port 1 :  $4N+1$  (1, 5.. 2557 pixel)

Port 2 :  $4N+2$  (2, 6.. 2558 pixel)

Port 3 :  $4N+3$  (3, 7.. 2559 pixel)

Port 4 :  $4N+4$  (4, 8.. 2560 pixel)

$N = 0, 1 \sim 639$

## 3.4.2 LVDS Data Format

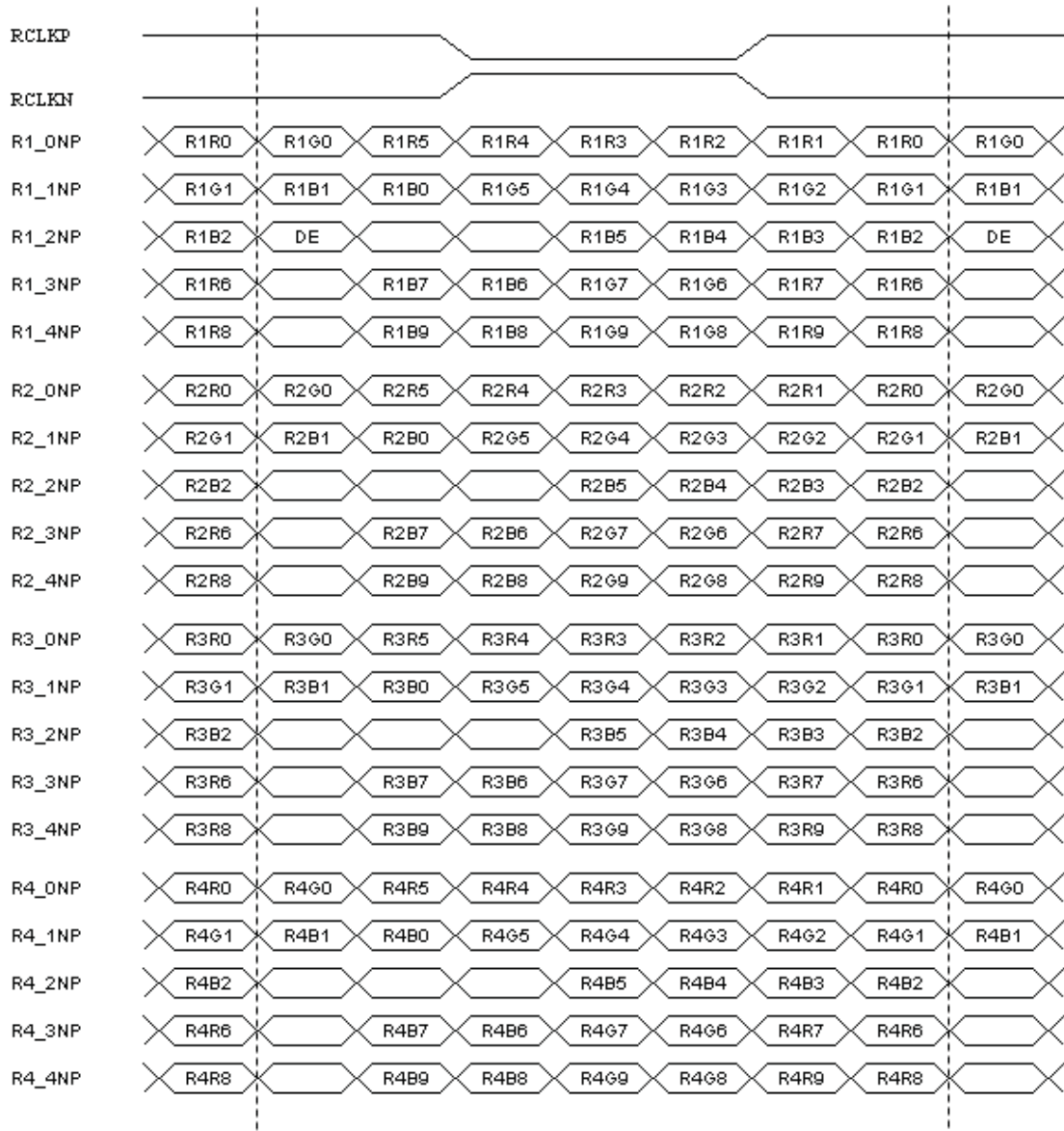

### 3.4.3 Color versus Input Data

The following table is for color versus input data (10bit). The higher the gray level, the brighter the color.

Color	Gray Level	Color Input Data																												Remark					
		RED data (MSB:R9,LSB:R0)										GREEN data (MSB:G9,LSB:G0)										BLUE data (MSB:B9,LSB:B0)													
		R9	R8	R7	R6	R5	R4	R3	R2	R1	R0	G9	G8	G7	G6	G5	G4	G3	G2	G1	G0	B9	B8	B7	B6	B5	B4	B3	B2		B1	B0			
Black	-	0	0	0	0	0	0	0	0	0	0	0	0	0	0	0	0	0	0	0	0	0	0	0	0	0	0	0	0	0	0	0			
White	-	1	1	1	1	1	1	1	1	1	1	1	1	1	1	1	1	1	1	1	1	1	1	1	1	1	1	1	1	1	1	1	1		
L511	-	0	1	1	1	1	1	1	1	1	1	1	0	1	1	1	1	1	1	1	1	0	1	1	1	1	1	1	1	1	1	1			
Red	L0	0	0	0	0	0	0	0	0	0	0	0	0	0	0	0	0	0	0	0	0	0	0	0	0	0	0	0	0	0	0	0	Black		
	:	:	:	:	:	:	:	:	:	:	:	:	:	:	:	:	:	:	:	:	:	:	:	:	:	:	:	:	:	:	:	:	:		
	L1023	1	1	1	1	1	1	1	1	1	1	1	0	0	0	0	0	0	0	0	0	0	0	0	0	0	0	0	0	0	0	0	0		
Green	L0	0	0	0	0	0	0	0	0	0	0	0	0	0	0	0	0	0	0	0	0	0	0	0	0	0	0	0	0	0	0	0	0	Black	
	:	:	:	:	:	:	:	:	:	:	:	:	:	:	:	:	:	:	:	:	:	:	:	:	:	:	:	:	:	:	:	:	:		
	L1023	0	0	0	0	0	0	0	0	0	0	0	1	1	1	1	1	1	1	1	1	1	0	0	0	0	0	0	0	0	0	0	0		
Blue	L0	0	0	0	0	0	0	0	0	0	0	0	0	0	0	0	0	0	0	0	0	0	0	0	0	0	0	0	0	0	0	0	0	Black	
	:	:	:	:	:	:	:	:	:	:	:	:	:	:	:	:	:	:	:	:	:	:	:	:	:	:	:	:	:	:	:	:	:	:	
	L1023	0	0	0	0	0	0	0	0	0	0	0	0	0	0	0	0	0	0	0	0	0	1	1	1	1	1	1	1	1	1	1	1		



Supply & Pu

### 3.4.4 LVDS Specification

#### a. DC Characteristics:

Symbol	Description	Min	Typ	Max	Units	Condition
$V_{TH}$	LVDS Differential Input High Threshold	-	-	+100	[mV]	$V_{CM} = 1.2V$
$V_{TL}$	LVDS Differential Input Low Threshold	-100	-	-	[mV]	$V_{CM} = 1.2V$
$ V_{ID} $	LVDS Differential Input Voltage	100	-	600	[mV]	
$V_{CM}$	LVDS Common Mode Voltage	+1.0	+1.2	+1.5	[V]	$V_{TH} - V_{TL} = 200mV$

#### LVDS Signal Waveform:

##### Single-End

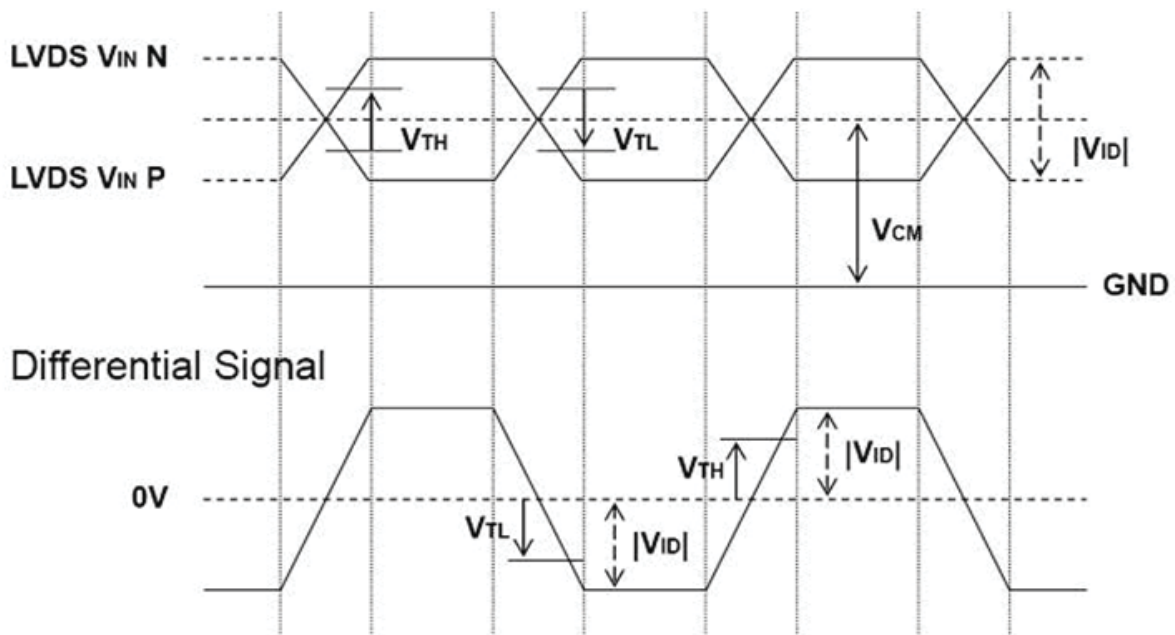

## b. AC Characteristics:

Symbol	Description	Min	Max	Unit	Remark
$F_{DEV}$	Maximum deviation of input clock frequency during Spread Spectrum	-	$\pm 3$	%	
$F_{MOD}$	Maximum modulation frequency of input clock during Spread Spectrum	-	200	KHz	

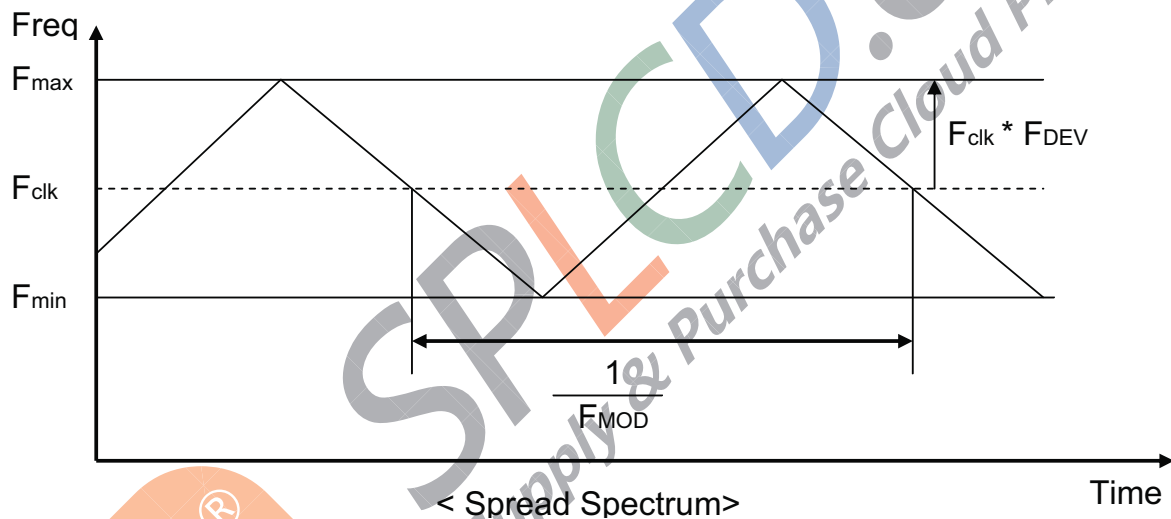

$F_{clk}$ : LVDS Clock Frequency

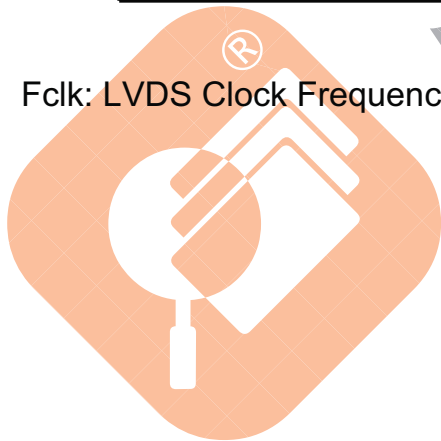

### 3.4.5 Input Timing Specification

It only support DE mode, and the input timing are shown as the following table.

Symbol	Description		Min.	Typ.	Max.	Unit	Remark
Tv	Vertical Section	Period	1452	1481	2347	Th	
Tdisp (v)		Active	1440	1440	1440	Th	
Tblk (v)		Blanking	12	41	907	Th	
Fv		Frequency	49	60	76	Hz	
Th	Horizontal Section	Period	665	680	1023	Tclk	
Tdisp (h)		Active	640	640	640	Tclk	
Tblk (h)		Blanking	25	40	383	Tclk	
Fh		Frequency	71.3	88.8	115.0	KHz	<b>Note 3-3</b>
Tclk	LVDS Clock	Period	13.1	16.6	21.0	ns	1/Fclk
Fclk		Frequency	47.4	60.4	76.5	MHz	<b>Note 3-4</b>

**Note 3-3:** The equation is listed as following. Please don't exceed the above recommended value.

$$Fh (\text{Min.}) = Fclk (\text{Min.}) / Th (\text{Min.});$$

$$Fh (\text{Typ.}) = Fclk (\text{Typ.}) / Th (\text{Typ.});$$

$$Fh (\text{Max.}) = Fclk (\text{Max.}) / Th (\text{Min.});$$

**Note 3-4:** The equation is listed as following. Please don't exceed the above recommended value.

$$Fclk (\text{Min.}) = Fv (\text{Min.}) \times Th (\text{Min.}) \times Tv (\text{Min.});$$

$$Fclk (\text{Typ.}) = Fv (\text{Typ.}) \times Th (\text{Typ.}) \times Tv (\text{Typ.});$$

$$Fclk (\text{Max.}) = Fv (\text{Max.}) \times Th (\text{Typ.}) \times Tv (\text{Typ.});$$

### 3.4.6 Input Timing Diagram

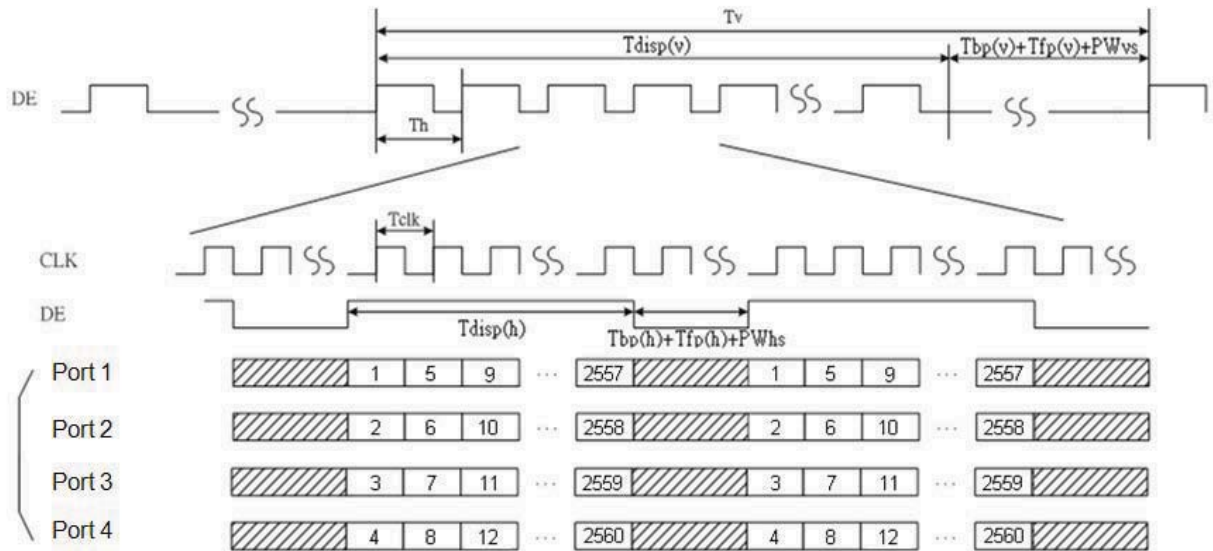

SPL  
Supply & Purchas





### 3.5 Power ON/OFF Sequence

VDD power, LVDS signal and backlight on/off sequence are as following. LVDS signals from any system shall be Hi-Z state when VDD is off.

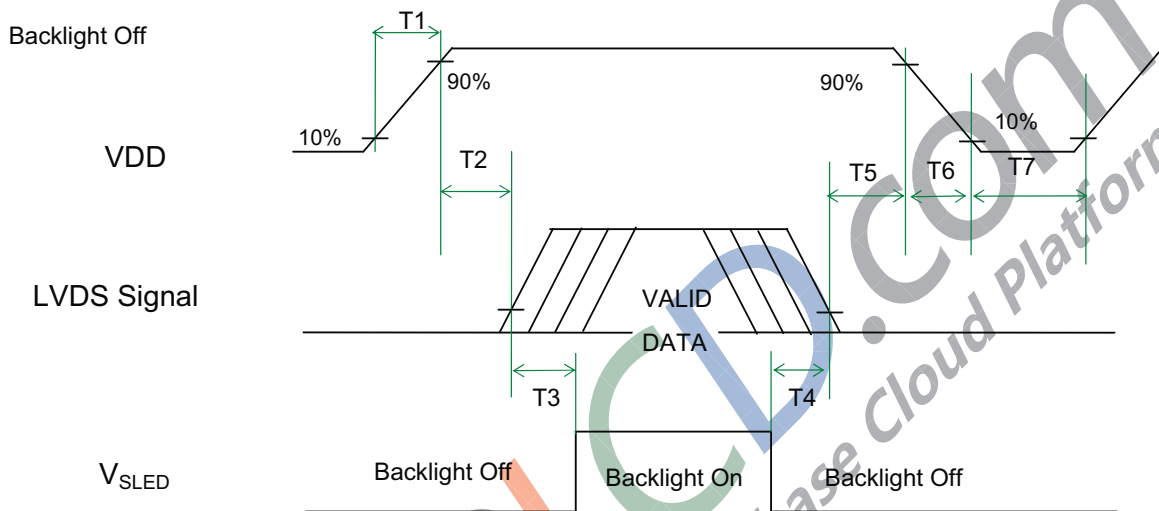

Power Sequence Timing

Symbol	Value			Unit	Remark
	Min.	Typ.	Max.		
T1	0.5	-	10	[ms]	
T2	0	-	50	[ms]	
T3	500	-	-	[ms]	
T4	100	-	-	[ms]	
T5	0	-	50	[ms]	<b>Note 3-5</b> <b>Note 3-6</b>
T6	5	-	150	[ms]	<b>Note 3-6</b>
T7	1000	-	-	[ms]	

**Note 3-5 :** Recommend setting T5 = 0ms to avoid electronic noise when VDD is off.

**Note 3-6 :** During T5 and T6 period , please keep the level of input LVDS signals with Hi-Z state.

## 4 Backlight Unit

### 4.1 Block Diagram

The following shows the block diagram of 27 inch Backlight Unit. And it includes 68 LED in the LED light bar .(4 strings and 17 pcs LED of one string).

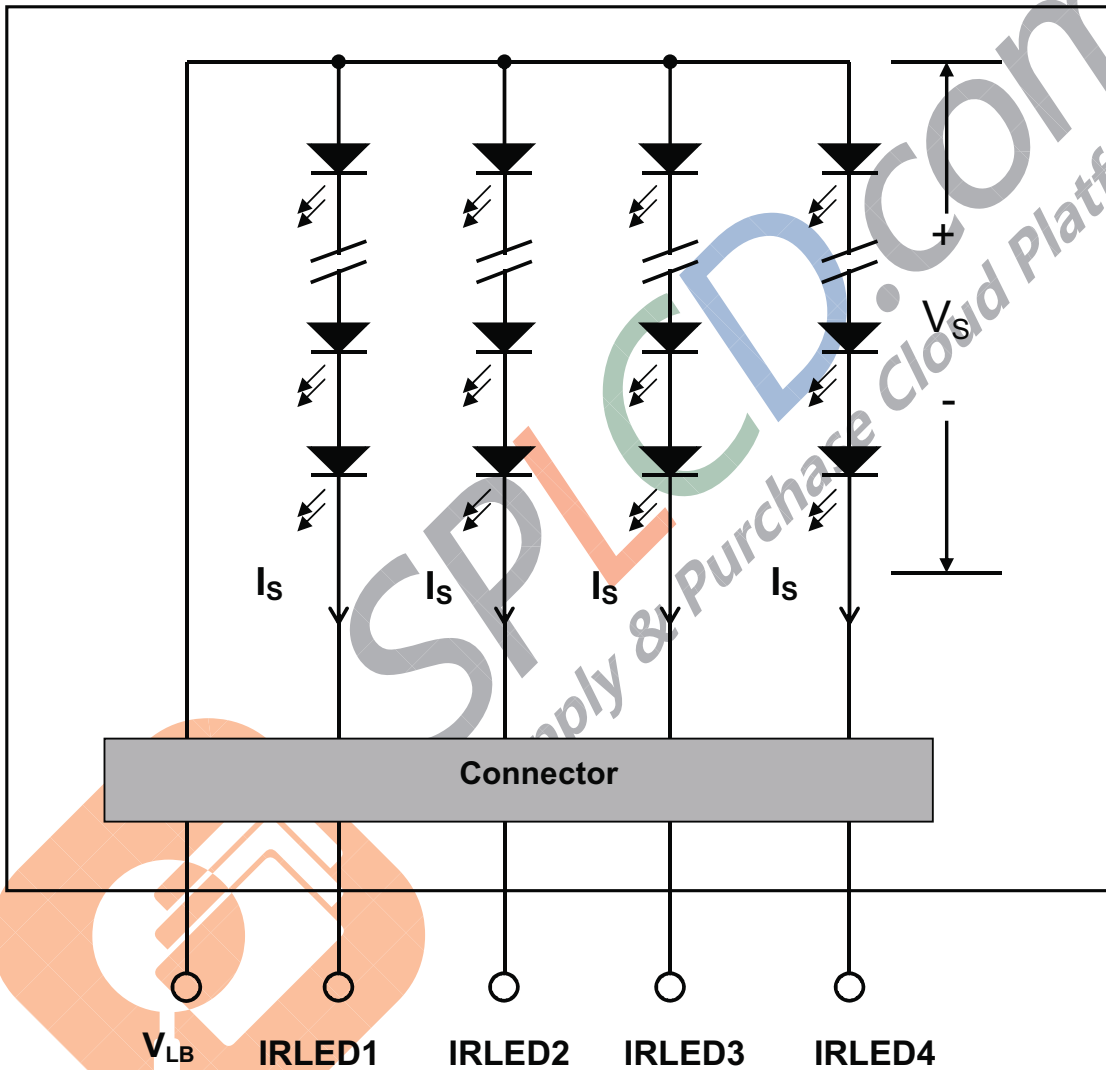

## 4.2 Interface Connection

### 4.2.1 Connector Type

Backlight Connector	Manufacturer	ENTERY
	Part Number	3707K-S06N-21R
Mating Connector	Manufacturer	ENTERY
	Part Number	H112K-P06N-13B (Locked Type)

Backlight Connector dimension:

Connector

3707K-S06N-21R

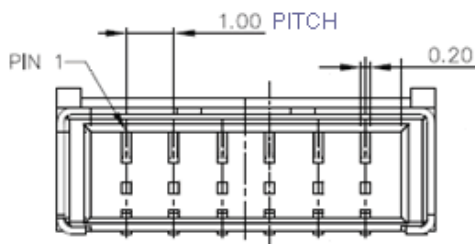
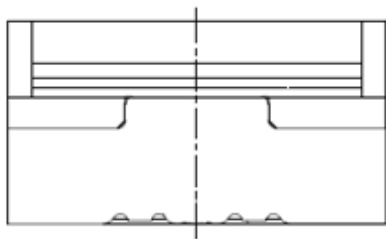

## Mating Connector dimension:

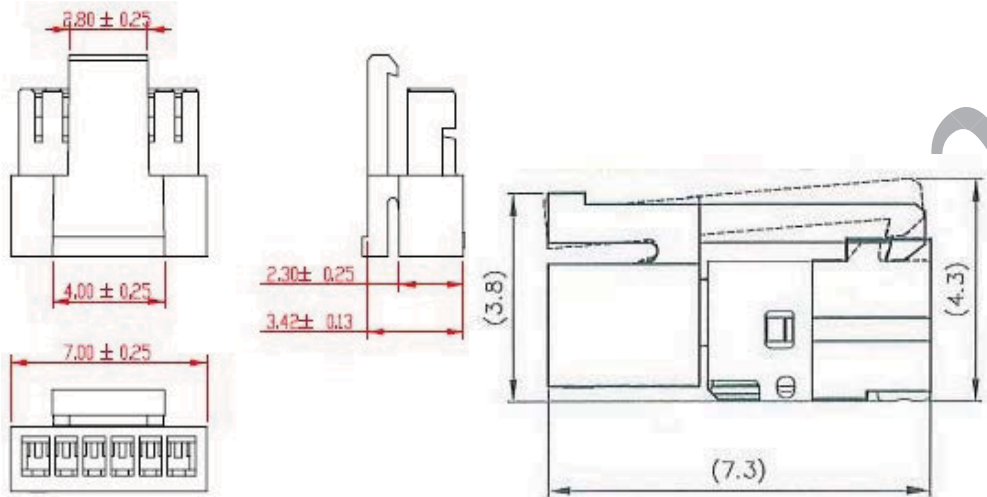

SPLCL  
Supply & Purchase Clo

## 4.2.2 Connector Pin Assignment

Pin#	Symbol	Description	Remark
1	Ch1	LED Current Feedback Terminal (Channel 1)	
2	Ch2	LED Current Feedback Terminal (Channel 2)	
3	V <sub>SLED</sub>	LED Power Supply Voltage Input Terminal	
4	V <sub>SLED</sub>	LED Power Supply Voltage Input Terminal	
5	Ch3	LED Current Feedback Terminal (Channel 3)	
6	Ch4	LED Current Feedback Terminal (Channel 4)	

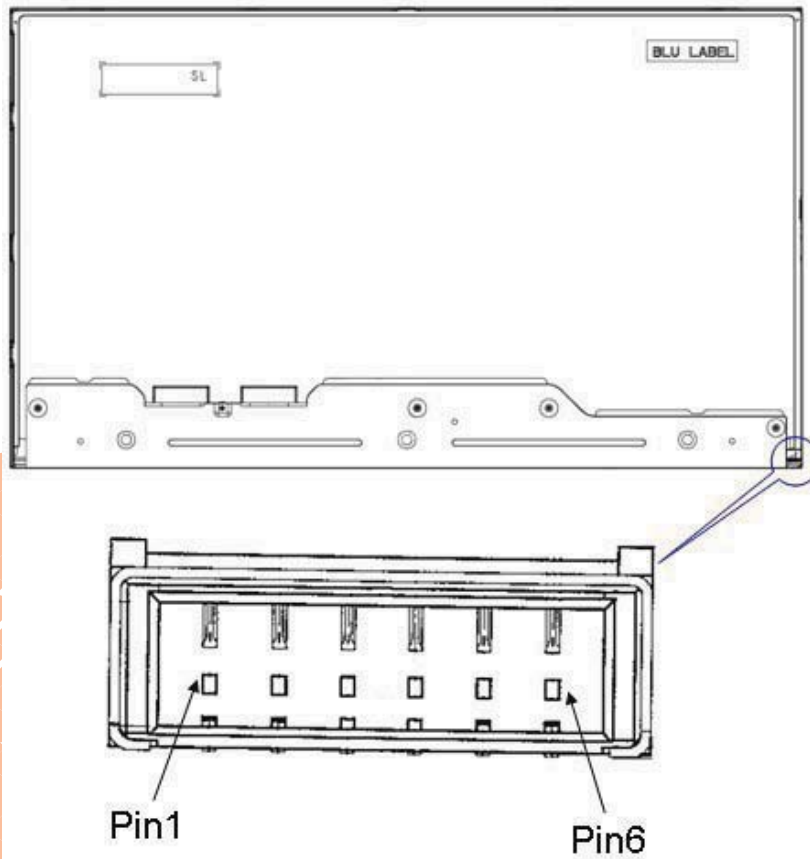

## 4.3 Electrical Characteristics

### 4.3.1 Absolute Maximum Rating

Permanent damage may occur if exceeding the following maximum rating.

(Ta=25°C)

Symbol	Description	Min	Max	Unit	Remark
Is	LED String Current	0	150	[mA]	100% duty ratio
			300	[mA]	Duty ratio ≤ 10% Pulse time=10 ms

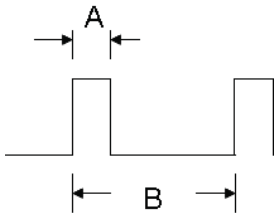

Duty ratio= (A / B) X 100% ; (A: Pulse time, B: Period)

### 4.3.2 Recommended Operating Condition

(Ta=25°C)

Symbol	Description	Min.	Typ.	Max.	Unit	Remark
Is	LED String Current	-	110	120	[mA]	100% duty ratio of LED chip
Vs	LED String Voltage	47.6	52.7	57.8	[Volt]	Is=110mA @ 100% duty ratio; <b>Note 4-1, Note 4-5</b>
ΔVs	Maximum Vs Voltage Deviation of light bar	-	-	3.4	[Volt]	Is=110mA @ 100% duty ratio; <b>Note 4-2</b>
P <sub>BLU</sub>	LED Light Bar Power Consumption	-	23.2	25.4	[Watt]	<b>Note 4-3</b>
LT <sub>LED</sub>	LED Life Time	30,000	-	-	[Hour]	<b>Note 4-4</b>
OVP	Over Voltage Protection in system board	110% V <sub>smax</sub>	-	-	[Volt]	<b>Note 4-5</b>

**Note 4-1:**  $V_s$  (Typ.) =  $V_F$  (Typ.) X LED No. (one string);

a.  $V_F$ : LED chip forward voltage,  $V_F$  (Min.)=2.8 V,  $V_F$ (Typ.)=3.1V,  $V_F$ (Max.)=3.4V;

b. The same equation to calculate  $V_s$ (Min.) &  $V_s$  (Max.) for respective  $V_F$  (Min.) &  $V_F$ (Max.);

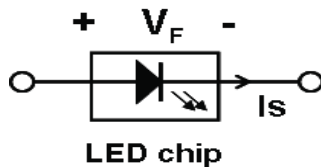

**Note 4-2:**  $\Delta V_s$  (Max.) =  $\Delta V_F$  X LED No. (one string);

a.  $\Delta V_F$ : LED chip forward voltage deviation; (0.2 V , each Bin of LED  $V_F$ )

**Note 4-3:**  $P_{BLU}$  (Typ.) = [  $V_s$  (Typ.) X  $I_s$  (Typ.) ] X 4

$P_{BLU}$  (Max.) = [  $V_s$  (Max.) X  $I_s$  (Typ.) ] X 4

("4" is total LED Light bar string of single Backlight Unit.)

**Note 4-4:** Definition of life time:

a. Brightness of LED becomes to 50% of its original value

b. Test condition:  $I_s$  = 110mA and 25°C (Room Temperature)

**Note 4-5:** Recommendation for LED driver power design:

Due to there are electrical property deviation in LED & monitor set system component after long time operation. AUO strongly recommend the design value of LED driver board OVP (over voltage protection) should be 10% higher than max. value of LED string voltage ( $V_s$ ) at least

**Note 4-6:** AUO strongly recommend "Analog Dimming" method for backlight brightness control for Wavy Noise Free. Otherwise, recommend that Dimming Control Signal (PWM signal) should be synchronized with Frame Frequency.



5 Reliability Test

AUO reliability test items are listed as following table. (Bare Panel only)

Items	Condition	Remark
Temperature Humidity Bias (THB)	Ta= 50°C, 80%RH, 300hours	
High Temperature Operation (HTO)	Ta= 50°C, 50%RH, 300hours	
Low Temperature Operation (LTO)	Ta= 0°C, 300hours	
High Temperature Storage (HTS)	Ta= 60°C, 300hours	
Low Temperature Storage (LTS)	Ta= -20°C, 300hours	
Vibration Test (Non-operation)	Acceleration: 1.5 Grms Wave: Random Frequency: 10 - 200 Hz Sweep: 30 Minutes each Axis (X, Y, Z)	
Shock Test (Non-operation)	Acceleration: 50 G Wave: Half-sine Active Time: 20 ms Direction: ±X, ±Y, ±Z (one time for each Axis)	
Thermal Shock Test (TST)	-20°C/30min, 60°C/30min, 100 cycles	<b>Note 5-1</b>
On/Off Test	On/10sec, Off/10sec, 30,000 cycles	
ESD (Electro Static Discharge)	Contact Discharge: ± 15KV, 150pF(330Ω ) 1sec, 8 points, 25 times/ point.	<b>Note 5-2</b>
	Air Discharge: ± 15KV, 150pF(330Ω ) 1sec 8 points, 25 times/ point.	
Altitude Test	Operation:18,000 ft Non-Operation:40,000 ft	

**Note 5-1:** a. A cycle of rapid temperature change consists of varying the temperature from -20°C to 60°C, and back again. Power is not applied during the test.  
b. After finish temperature cycling, the unit is placed in normal room ambient for at least 4 hours before power on.

**Note 5-2:** EN61000-4-2, ESD class B: Certain performance degradation allowed  
No data lost  
Self-recoverable  
No hardware failures.



## 6 Shipping Label

The label is on the panel as shown below:

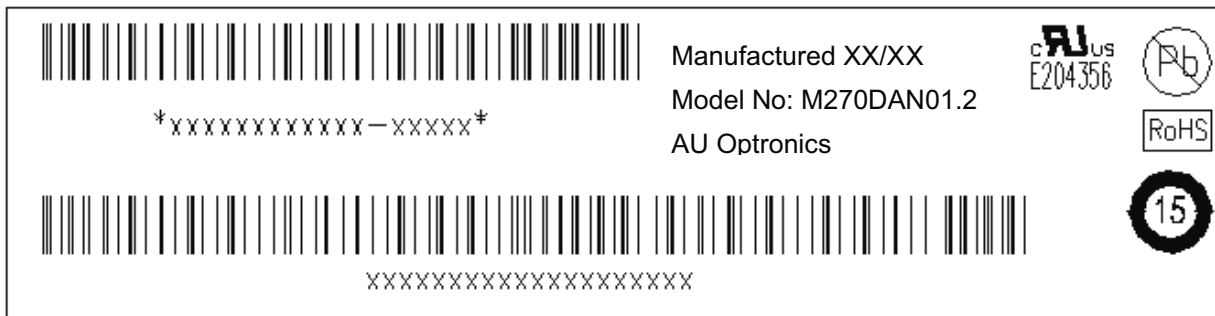

**Note 6-1:** For Pb Free products, AUO will add  for identification.

**Note 6-2:** For RoHS compatible products, AUO will add  for identification.

**Note 6-3:** For China RoHS compatible products, AUO will add  for identification.

**Note 6-4:** The Green Mark will be presented only when the green documents have been ready by AUO Internal Green Team.



## 7 Mechanical Characteristics

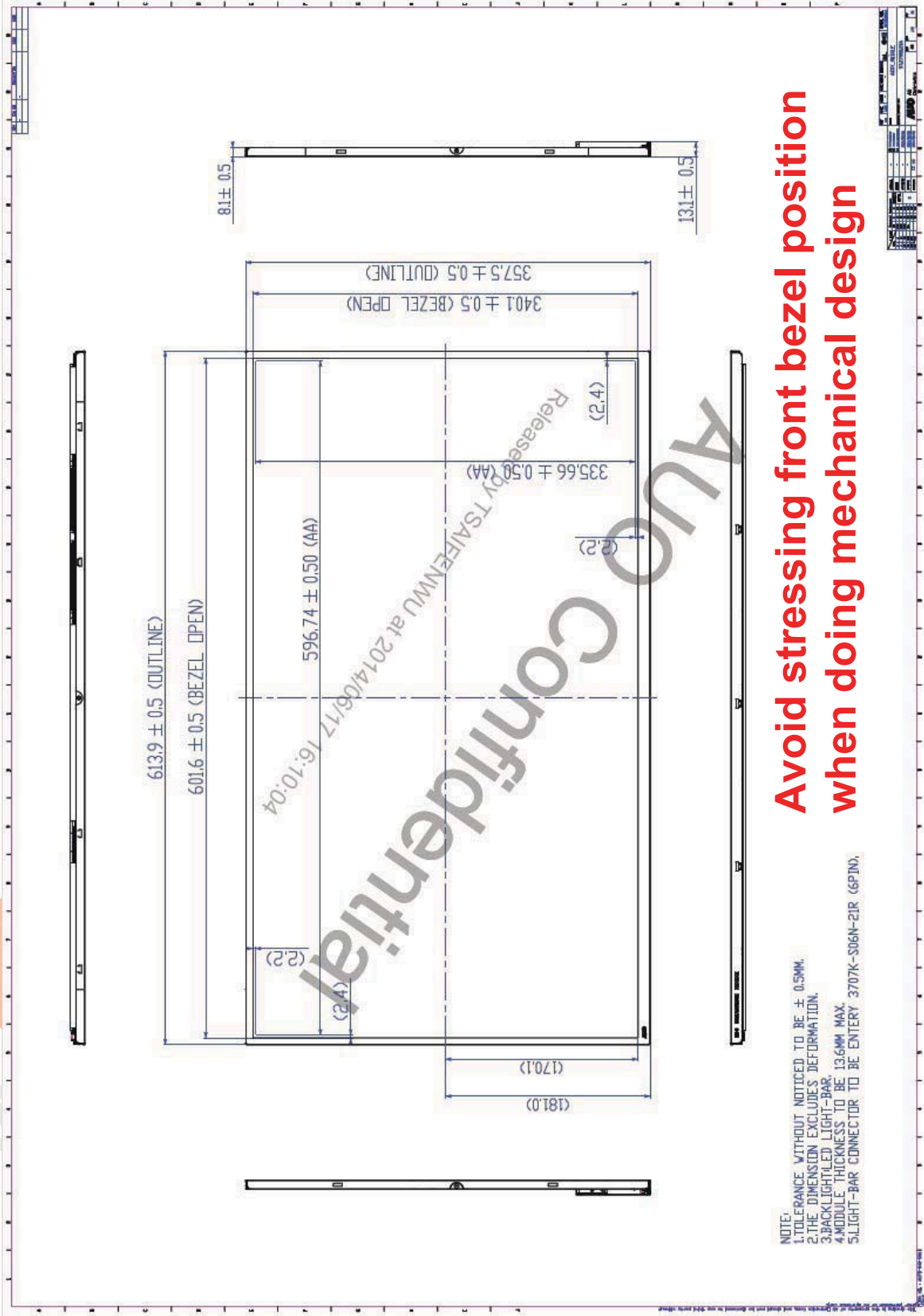

**Avoid stressing front bezel position  
when doing mechanical design**

Ver 0.1



## 8 Packing Specification

### 8.1 Packing Flow

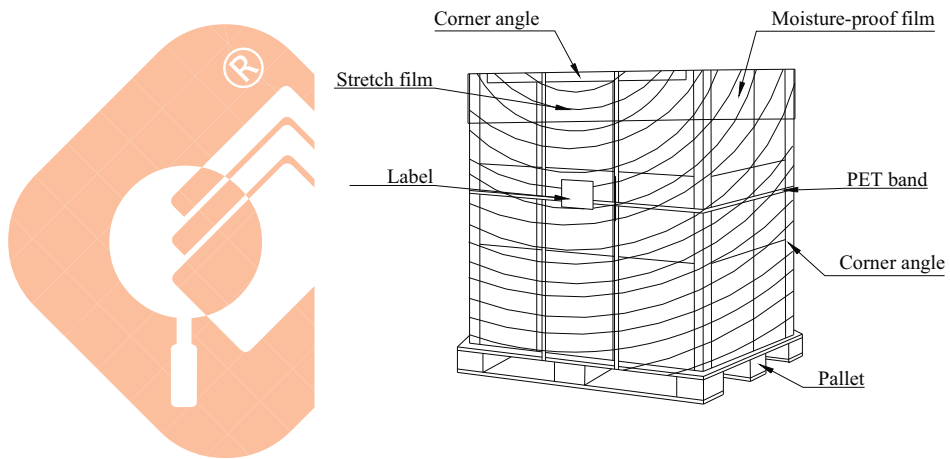
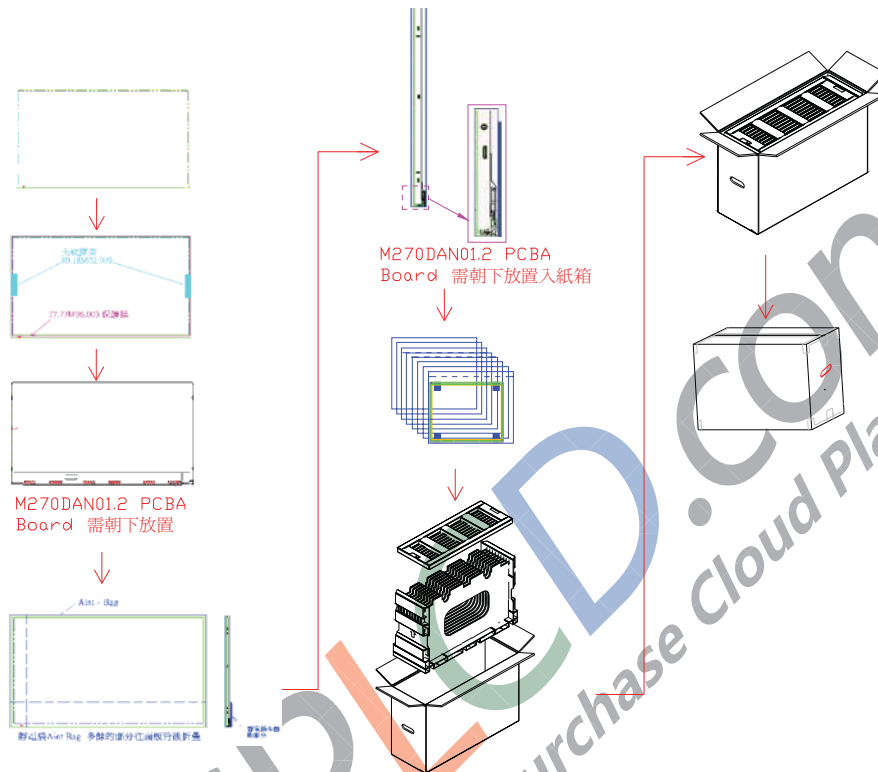

## 8.2 Pallet and shipment information

Item	Specification			Remark
	Q'ty	Dimension	Weight (kg)	
Panel	1	613.9 (H)mmX357.5(V)mm x 13.1(D) mm	3.48	
Cushion	1	-	<b>3.23</b>	
Box	1	720(L)mm x 264(W)mm x <b>456(H)mm</b>	<b>1.22</b>	without Panel & cushion
Packing Box	8 pcs/Box	720(L)mm x 264(W)mm x <b>456(H)mm</b>	<b>32.3</b>	with panel & cushion
Pallet	1	1070(L)mm x 740(W)mm x 138(H)mm	14.8	
Pallet after Packing	8 boxes/pallet	1070(L)mm x 740(W)mm x 1060(H)mm	<b>273.2</b>	



**SPLCD.COM**  
Supply & Purchase Cloud Platform