



() Preliminary Specification

(V) Final Specification

Module	27" Color TFT-LCD
Model Name	M270DTN01.0

<table style="width: 100%; border-collapse: collapse;"> <tr> <td style="width: 50%; text-align: center;">Customer</td> <td style="width: 50%; text-align: center;">Date</td> </tr> <tr> <td style="text-align: center;">_____</td> <td style="text-align: center;">_____</td> </tr> <tr> <td style="text-align: center;">Approved by </td> <td></td> </tr> <tr> <td style="text-align: center;">_____</td> <td style="text-align: center;">_____</td> </tr> </table> <p>Note: This Specification is subject to change without notice.</p>	Customer	Date	_____	_____	Approved by 		_____	_____	<table style="width: 100%; border-collapse: collapse;"> <tr> <td style="width: 50%; text-align: center;">Approved by</td> <td style="width: 50%; text-align: center;">Date</td> </tr> <tr> <td style="text-align: center;"><u>Howard Lee</u></td> <td style="text-align: center;"><u>Jan 06, 2015</u></td> </tr> <tr> <td style="text-align: center;">Prepared by</td> <td style="text-align: center;">Date</td> </tr> <tr> <td style="text-align: center;"><u>Cherrychiu</u></td> <td style="text-align: center;"><u>Jan 06, 2015</u></td> </tr> </table> <p style="text-align: center;">AU Optronics corporation</p>	Approved by	Date	<u>Howard Lee</u>	<u>Jan 06, 2015</u>	Prepared by	Date	<u>Cherrychiu</u>	<u>Jan 06, 2015</u>
Customer	Date																
_____	_____																
Approved by 																	
_____	_____																
Approved by	Date																
<u>Howard Lee</u>	<u>Jan 06, 2015</u>																
Prepared by	Date																
<u>Cherrychiu</u>	<u>Jan 06, 2015</u>																

Contents

1 Handling Precautions.....	6
2 General Description	7
2.1 Display Characteristics.....	7
2.2 Absolute Maximum Rating of Environment	8
2.3 Optical Characteristics	9
3 TFT-LCD Module.....	13
3.1 Block Diagram.....	13
3.2 Interface Connection.....	14
3.2.1 Connector Type.....	14
3.2.2 Connector Pin Assignment.....	14
3.3 Electrical Characteristics.....	19
3.3.1 Absolute Maximum Rating	19
3.3.2 Recommended Operating Condition.....	19
3.4 Signal Characteristics	20
3.4.1 LCD Pixel Format.....	20
3.4.2 LVDS Data Format.....	21
3.4.3 Color versus Input Data	23
3.4.4 LVDS Specification.....	24
3.4.5 Input Timing Specification	26
3.4.6 Input Timing Diagram.....	27
3.4.7 3D control.....	26
3.5 Power ON/OFF Sequence	30
4 Backlight Unit.....	31
4.1 Block Diagram.....	31
4.2 Interface Connection.....	32
4.2.1 Connector Type.....	32
4.2.2 Connector Pin Assignment.....	33
4.3 Electrical Characteristics.....	34
4.3.1 Absolute Maximum Rating	34
4.3.2 Recommended Operating Condition.....	34
5 Reliability Test.....	36
6 Shipping Label	37
7 Mechanical Characteristics.....	38
8 Packing Specification.....	40
8.1 Packing Flow.....	40
8.2 Pallet and shipment information.....	41

Record of Revision

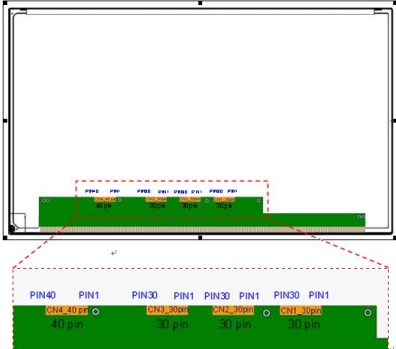
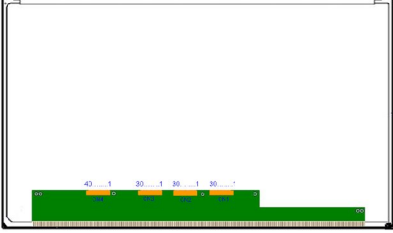
Version	Date	Page	Old description	New Description	Remark
0.0	2013/07/15	All	First version release	-	
0.1	2013/10/28	P6.	2.1 Display Characteristics BLU power=27.3(W) 34.3 (Typ.) LCD module : PDD (Typ.)=7.0 @ Black pattern,Fv=144Hz Backlight unit : P _{BLU} (Typ.) =27.3 @Is=120mA	2.1 Display Characteristics BLU power=27.2(W) 34.3 (Typ.) LCD module : PDD (Typ.)=7.0 @ Black pattern,Fv=144Hz Backlight unit : P _{BLU} (Typ.) = 27.2 @Is=120mA	
		P8.	2.3 optical Characteristics Response Time Response Time ¹⁾ Rising Time ²⁾ -- ³⁾ 3.8 ²⁾ 5.5 ²⁾ Falling Time ²⁾ -- ³⁾ 1.2 ²⁾ 2.5 ²⁾ Rising + Falling ²⁾ -- ³⁾ 5 ²⁾ 8 ²⁾	2.3 optical Characteristics Response Time Response Time ¹⁾ Rising Time ²⁾ -- ³⁾ 3.5 ²⁾ 5.5 ²⁾ Falling Time ²⁾ -- ³⁾ 1.5 ²⁾ 2.5 ²⁾ Rising + Falling ²⁾ -- ³⁾ 5 ²⁾ 8 ²⁾	
		P8.	2.3 optical Characteristics RGB Color Coodinates Color Coordinates ¹⁾ (CIE 1931) ²⁾ Red x ³⁾ TBD ²⁾ TBD ²⁾ TBD ²⁾ Red y ³⁾ TBD ²⁾ TBD ²⁾ TBD ²⁾ Green x ³⁾ TBD ²⁾ TBD ²⁾ TBD ²⁾ Green y ³⁾ TBD ²⁾ TBD ²⁾ TBD ²⁾ Blue x ³⁾ TBD ²⁾ TBD ²⁾ TBD ²⁾ Blue y ³⁾ TBD ²⁾ TBD ²⁾ TBD ²⁾	2.3 optical Characteristics RGB Color Coodinates Color Coordinates ¹⁾ (CIE 1931) ²⁾ Red x ³⁾ 0.620 ²⁾ 0.650 ²⁾ 0.680 ²⁾ Red y ³⁾ 0.308 ²⁾ 0.338 ²⁾ 0.368 ²⁾ Green x ³⁾ 0.283 ²⁾ 0.313 ²⁾ 0.343 ²⁾ Green y ³⁾ 0.596 ²⁾ 0.626 ²⁾ 0.656 ²⁾ Blue x ³⁾ 0.120 ²⁾ 0.150 ²⁾ 0.180 ²⁾ Blue y ³⁾ 0.022 ²⁾ 0.052 ²⁾ 0.082 ²⁾	
		P9	2.3 Optical Characteristics 3. VDD=12.0V, Fv=144Hz, Ta=25°C	2.3 Optical Characteristics 3. VDD=12.0V, Fv=144Hz, Is=120mA , Ta=25°C	
		P12	3.2.1 Connector Type TFT-LCD Connector ¹⁾ Manufacturer ²⁾ STM ²⁾ Starcom ²⁾ Part Number ³⁾ MSCKT2407P30H- (CN1 / CN2 / CN3) Mating Connector ⁴⁾ Manufacturer ²⁾ STM ²⁾ Starcom ²⁾ Part Number ³⁾ PK2407P30V ²⁾ FLN040H ²⁾	3.2.1 Connector Type TFT-LCD Connector ¹⁾ Manufacturer ²⁾ STM ²⁾ Starcom ²⁾ Part Number ³⁾ MSCKT2407P30H- (CN1 / CN2 / CN3) Mating Connector ⁴⁾ Manufacturer ²⁾ STM or compatible ²⁾ JAE or compatible ²⁾ Part Number ³⁾ PK2407P30V ²⁾ FLN040H ²⁾	
		P17	3.2.2 Connector Pin Assignment 示意圖 	3.2.2 Connector Pin Assignment 示意圖 	
		P19	3.4.1 LCD Pixel Format Note 1) The module use 8 port-LVDS interface. Port 1 : 1, 9→2557pixel →BN+1 N=0,~ 319 (1,9, 2553pixel) Port 2 : 2, 10→2558pixel →BN+2 N=0,~ 319 (2,10, 2554pixel) Port 3 : 3, 11→2559 pixel →BN+3 N=0,~ 319 (3,11, 2555pixel) Port 4 : 4, 12→2560 pixel →BN+4 N=0,~ 319 (4,12, 2556pixel) Port 5 : 5, 13→2557pixel →BN+5 N=0,~ 319 (5,13, 2557pixel) Port 6 : 5, 14→2558pixel →BN+6 N=0,~ 319 (6,14, 2558pixel) Port 7 : 7, 15→2559 pixel →BN+7 N=0,~ 319 (7,15, 2559pixel) Port 8 : 8, 16→2560 pixel →BN+8 N=0,~ 319 (8,16, 2560pixel)	3.4.1 LCD Pixel Format	

				<p>Note 3-2: The module use 8 port-LVDS interface</p> <p>Port 1 : 8N+1 N=0, ~ 319 (1.9, 2553pixel)- Port 2 : 8N+2 N=0, ~ 319 (2.10, 2554pixel)- Port 3 : 8N+3 N=0, ~ 319 (3.11, 2555pixel)- Port 4 : 8N+4 N=0, ~ 319 (4.12, 2556pixel)- Port 5 : 8N+5 N=0, ~ 319 (5.13, 2557pixel)- Port 6 : 8N+6 N=0, ~ 319 (6.14, 2558pixel)- Port 7 : 8N+7 N=0, ~ 319 (7.15, 2559pixel)- Port 8 : 8N+8 N=0, ~ 319 (8.16, 2560pixel)-</p>																																																																																																	
		P23	<h3>3.4.4 LVDS Specification</h3> <p>LVDS Signal Waveform:- Use RxOCLK- & RxOCLK+ as example -></p>	<h3>3.4.4 LVDS Specification</h3> <p>Use RxCLKN & RxCLKP as example -></p>																																																																																																	
		P25	<h3>3.4.5 Input Timing Specification</h3> <table border="1"> <tr> <td>F_{in}</td> <td>Frequency</td> <td>172.5</td> <td>213.3</td> <td>317.9</td> <td>KHz</td> <td>Note 3-3</td> </tr> </table>	F _{in}	Frequency	172.5	213.3	317.9	KHz	Note 3-3	<h3>3.4.5 Input Timing Specification</h3> <table border="1"> <tr> <td>F_{in}</td> <td>Frequency</td> <td>173</td> <td>213</td> <td>318</td> <td>KHz</td> <td>Note 3-3</td> </tr> </table>	F _{in}	Frequency	173	213	318	KHz	Note 3-3																																																																																			
F _{in}	Frequency	172.5	213.3	317.9	KHz	Note 3-3																																																																																															
F _{in}	Frequency	173	213	318	KHz	Note 3-3																																																																																															
		P28	<h3>3.4.7.3. Recommended Operating Condition</h3> <table border="1"> <tr> <td>V_{OH}</td> <td>Output High Voltage</td> <td>I_{OH} = 4mA</td> <td>2.4</td> <td>-</td> <td>-</td> <td>-</td> </tr> <tr> <td>V_{OL}</td> <td>Output Low Voltage</td> <td>I_{OL} = -4mA</td> <td>-</td> <td>-</td> <td>-</td> <td>0.4</td> </tr> </table>	V _{OH}	Output High Voltage	I _{OH} = 4mA	2.4	-	-	-	V _{OL}	Output Low Voltage	I _{OL} = -4mA	-	-	-	0.4	<h3>3.4.7.3. Recommended Operating Condition</h3> <table border="1"> <tr> <td>V_{OH}</td> <td>Output High Voltage</td> <td>I_{OH} = 4mA</td> <td>2.4</td> <td>-</td> <td>-</td> <td>3.4</td> </tr> <tr> <td>V_{OL}</td> <td>Output Low Voltage</td> <td>I_{OL} = -4mA</td> <td>0</td> <td>-</td> <td>-</td> <td>0.4</td> </tr> </table>	V _{OH}	Output High Voltage	I _{OH} = 4mA	2.4	-	-	3.4	V _{OL}	Output Low Voltage	I _{OL} = -4mA	0	-	-	0.4																																																																					
V _{OH}	Output High Voltage	I _{OH} = 4mA	2.4	-	-	-																																																																																															
V _{OL}	Output Low Voltage	I _{OL} = -4mA	-	-	-	0.4																																																																																															
V _{OH}	Output High Voltage	I _{OH} = 4mA	2.4	-	-	3.4																																																																																															
V _{OL}	Output Low Voltage	I _{OL} = -4mA	0	-	-	0.4																																																																																															
		P29	<h3>3.5 Power ON/OFF Sequence</h3> <table border="1"> <thead> <tr> <th>Symbol</th> <th>Min.</th> <th>Typ.</th> <th>Max.</th> <th>Unit</th> <th>Remark</th> </tr> </thead> <tbody> <tr> <td>T1</td> <td>0.5</td> <td>-</td> <td>10</td> <td>[ms]</td> <td>-</td> </tr> <tr> <td>T2</td> <td>0</td> <td>-</td> <td>50</td> <td>[ms]</td> <td>-</td> </tr> <tr> <td>T3</td> <td>500</td> <td>-</td> <td>-</td> <td>[ms]</td> <td>-</td> </tr> <tr> <td>T4</td> <td>100</td> <td>-</td> <td>-</td> <td>[ms]</td> <td>-</td> </tr> <tr> <td>T5</td> <td>0</td> <td>-</td> <td>50</td> <td>[ms]</td> <td>Note 3-5 Note 3-6</td> </tr> <tr> <td>T6</td> <td>0</td> <td>-</td> <td>100</td> <td>[ms]</td> <td>-</td> </tr> <tr> <td>T7</td> <td>1000</td> <td>-</td> <td>-</td> <td>[ms]</td> <td>-</td> </tr> </tbody> </table> <p>Note 3-5: Recommend setting T5 = 0ms to avoid electronic noise when VDD is off -> Note 3-6: During T5 and T6 period, please keep the level of input LVDS signals with Hi-Z state.</p>	Symbol	Min.	Typ.	Max.	Unit	Remark	T1	0.5	-	10	[ms]	-	T2	0	-	50	[ms]	-	T3	500	-	-	[ms]	-	T4	100	-	-	[ms]	-	T5	0	-	50	[ms]	Note 3-5 Note 3-6	T6	0	-	100	[ms]	-	T7	1000	-	-	[ms]	-	<h3>3.5 Power ON/OFF Sequence</h3> <table border="1"> <thead> <tr> <th>Symbol</th> <th>Min.</th> <th>Typ.</th> <th>Max.</th> <th>Unit</th> <th>Remark</th> </tr> </thead> <tbody> <tr> <td>T1</td> <td>0.5</td> <td>-</td> <td>10</td> <td>[ms]</td> <td>-</td> </tr> <tr> <td>T2</td> <td>0</td> <td>-</td> <td>50</td> <td>[ms]</td> <td>-</td> </tr> <tr> <td>T3</td> <td>500</td> <td>-</td> <td>-</td> <td>[ms]</td> <td>-</td> </tr> <tr> <td>T4</td> <td>100</td> <td>-</td> <td>-</td> <td>[ms]</td> <td>-</td> </tr> <tr> <td>T5</td> <td>0</td> <td>-</td> <td>50</td> <td>[ms]</td> <td>Note 3-5 Note 3-6 Note 3-7</td> </tr> <tr> <td>T6</td> <td>0</td> <td>-</td> <td>100</td> <td>[ms]</td> <td>-</td> </tr> <tr> <td>T7</td> <td>1000</td> <td>-</td> <td>-</td> <td>[ms]</td> <td>-</td> </tr> </tbody> </table> <p>Note 3-6: Recommend setting T5 = 0ms to avoid electronic noise when VDD is off -> Note 3-7: During T5 and T6 period, please keep the level of input LVDS signals with Hi-Z state.</p>	Symbol	Min.	Typ.	Max.	Unit	Remark	T1	0.5	-	10	[ms]	-	T2	0	-	50	[ms]	-	T3	500	-	-	[ms]	-	T4	100	-	-	[ms]	-	T5	0	-	50	[ms]	Note 3-5 Note 3-6 Note 3-7	T6	0	-	100	[ms]	-	T7	1000	-	-	[ms]	-	
Symbol	Min.	Typ.	Max.	Unit	Remark																																																																																																
T1	0.5	-	10	[ms]	-																																																																																																
T2	0	-	50	[ms]	-																																																																																																
T3	500	-	-	[ms]	-																																																																																																
T4	100	-	-	[ms]	-																																																																																																
T5	0	-	50	[ms]	Note 3-5 Note 3-6																																																																																																
T6	0	-	100	[ms]	-																																																																																																
T7	1000	-	-	[ms]	-																																																																																																
Symbol	Min.	Typ.	Max.	Unit	Remark																																																																																																
T1	0.5	-	10	[ms]	-																																																																																																
T2	0	-	50	[ms]	-																																																																																																
T3	500	-	-	[ms]	-																																																																																																
T4	100	-	-	[ms]	-																																																																																																
T5	0	-	50	[ms]	Note 3-5 Note 3-6 Note 3-7																																																																																																
T6	0	-	100	[ms]	-																																																																																																
T7	1000	-	-	[ms]	-																																																																																																
		P31	<h3>4.2.1 Connector Type</h3> <table border="1"> <tr> <td>Backlight Connector</td> <td>Manufacturer</td> <td>ENTERY</td> </tr> <tr> <td>Part Number</td> <td colspan="2">3707K-S06N-21R</td> </tr> <tr> <td>Mating Connector</td> <td>Manufacturer</td> <td>ENTERY</td> </tr> <tr> <td>Part Number</td> <td colspan="2">H112K-P06N-00B (Non-Locking type) H112K-P06N-03B (Locking type)</td> </tr> </table>	Backlight Connector	Manufacturer	ENTERY	Part Number	3707K-S06N-21R		Mating Connector	Manufacturer	ENTERY	Part Number	H112K-P06N-00B (Non-Locking type) H112K-P06N-03B (Locking type)		<h3>4.2.1 Connector Type</h3> <table border="1"> <tr> <td>Backlight Connector</td> <td>Manufacturer</td> <td>ENTERY</td> </tr> <tr> <td>Part Number</td> <td colspan="2">3707K-S06N-21R</td> </tr> <tr> <td>Mating Connector</td> <td>Manufacturer</td> <td>ENTERY or compatible</td> </tr> <tr> <td>Part Number</td> <td colspan="2">H112K-P06N-00B (Non-Locking type) H112K-P06N-03B (Locking type)</td> </tr> </table>	Backlight Connector	Manufacturer	ENTERY	Part Number	3707K-S06N-21R		Mating Connector	Manufacturer	ENTERY or compatible	Part Number	H112K-P06N-00B (Non-Locking type) H112K-P06N-03B (Locking type)																																																																										
Backlight Connector	Manufacturer	ENTERY																																																																																																			
Part Number	3707K-S06N-21R																																																																																																				
Mating Connector	Manufacturer	ENTERY																																																																																																			
Part Number	H112K-P06N-00B (Non-Locking type) H112K-P06N-03B (Locking type)																																																																																																				
Backlight Connector	Manufacturer	ENTERY																																																																																																			
Part Number	3707K-S06N-21R																																																																																																				
Mating Connector	Manufacturer	ENTERY or compatible																																																																																																			
Part Number	H112K-P06N-00B (Non-Locking type) H112K-P06N-03B (Locking type)																																																																																																				
		P33	<h3>4.3.2 Recommended Operating Condition</h3> <p>(T_a=25°C)</p> <table border="1"> <thead> <tr> <th>Symbol</th> <th>Description</th> <th>Min.</th> <th>Typ.</th> <th>Max.</th> <th>Unit</th> <th>Remark</th> </tr> </thead> <tbody> <tr> <td>I_s</td> <td>LED String Current</td> <td>-</td> <td>120</td> <td>132</td> <td>[mA]</td> <td>100% duty ratio of LED chip.</td> </tr> <tr> <td>V_s</td> <td>LED String Voltage</td> <td>53.1</td> <td>56.7</td> <td>60.3</td> <td>[Volt]</td> <td>I_s=120mA @ 100% duty ratio. Note 4-1, Note 4-5.</td> </tr> <tr> <td>ΔV_s</td> <td>Maximum V_s Voltage Deviation of light bar</td> <td>-</td> <td>-</td> <td>3.6</td> <td>[Volt]</td> <td>I_s=120mA @ 100% duty ratio. Note 4-2.</td> </tr> <tr> <td>P_{LED}</td> <td>LED Light Bar Power Consumption</td> <td>-</td> <td>27.3</td> <td>29.0</td> <td>[Watt]</td> <td>Note 4-3.</td> </tr> <tr> <td>LT_{LED}</td> <td>LED Life Time</td> <td>30,000</td> <td>-</td> <td>-</td> <td>[Hour]</td> <td>Note 4-4.</td> </tr> </tbody> </table>	Symbol	Description	Min.	Typ.	Max.	Unit	Remark	I _s	LED String Current	-	120	132	[mA]	100% duty ratio of LED chip.	V _s	LED String Voltage	53.1	56.7	60.3	[Volt]	I _s =120mA @ 100% duty ratio. Note 4-1, Note 4-5.	ΔV _s	Maximum V _s Voltage Deviation of light bar	-	-	3.6	[Volt]	I _s =120mA @ 100% duty ratio. Note 4-2.	P _{LED}	LED Light Bar Power Consumption	-	27.3	29.0	[Watt]	Note 4-3.	LT _{LED}	LED Life Time	30,000	-	-	[Hour]	Note 4-4.	<h3>4.3.2 Recommended Operating Condition</h3> <table border="1"> <thead> <tr> <th>Symbol</th> <th>Description</th> <th>Min.</th> <th>Typ.</th> <th>Max.</th> <th>Unit</th> <th>Remark</th> </tr> </thead> <tbody> <tr> <td>I_s</td> <td>LED String Current</td> <td>-</td> <td>120</td> <td>132</td> <td>[mA]</td> <td>100% duty ratio of LED chip.</td> </tr> <tr> <td>V_s</td> <td>LED String Voltage</td> <td>53.1</td> <td>56.7</td> <td>60.3</td> <td>[Volt]</td> <td>I_s=120mA @ 100% duty ratio. Note 4-1, Note 4-5.</td> </tr> <tr> <td>ΔV_s</td> <td>Maximum V_s Voltage Deviation of light bar</td> <td>-</td> <td>-</td> <td>3.6</td> <td>[Volt]</td> <td>I_s=120mA @ 100% duty ratio. Note 4-2.</td> </tr> <tr> <td>P_{LED}</td> <td>LED Light Bar Power Consumption</td> <td>-</td> <td>27.2</td> <td>28.9</td> <td>[Watt]</td> <td>Note 4-3.</td> </tr> <tr> <td>LT_{LED}</td> <td>LED Life Time</td> <td>30,000</td> <td>-</td> <td>-</td> <td>[Hour]</td> <td>Note 4-4.</td> </tr> <tr> <td>OVP</td> <td>Over Voltage Protection in system board</td> <td>110%</td> <td>V_s max</td> <td>-</td> <td>[Volt]</td> <td>Note 4-5.</td> </tr> </tbody> </table>	Symbol	Description	Min.	Typ.	Max.	Unit	Remark	I _s	LED String Current	-	120	132	[mA]	100% duty ratio of LED chip.	V _s	LED String Voltage	53.1	56.7	60.3	[Volt]	I _s =120mA @ 100% duty ratio. Note 4-1, Note 4-5.	ΔV _s	Maximum V _s Voltage Deviation of light bar	-	-	3.6	[Volt]	I _s =120mA @ 100% duty ratio. Note 4-2.	P _{LED}	LED Light Bar Power Consumption	-	27.2	28.9	[Watt]	Note 4-3.	LT _{LED}	LED Life Time	30,000	-	-	[Hour]	Note 4-4.	OVP	Over Voltage Protection in system board	110%	V _s max	-	[Volt]	Note 4-5.						
Symbol	Description	Min.	Typ.	Max.	Unit	Remark																																																																																															
I _s	LED String Current	-	120	132	[mA]	100% duty ratio of LED chip.																																																																																															
V _s	LED String Voltage	53.1	56.7	60.3	[Volt]	I _s =120mA @ 100% duty ratio. Note 4-1, Note 4-5.																																																																																															
ΔV _s	Maximum V _s Voltage Deviation of light bar	-	-	3.6	[Volt]	I _s =120mA @ 100% duty ratio. Note 4-2.																																																																																															
P _{LED}	LED Light Bar Power Consumption	-	27.3	29.0	[Watt]	Note 4-3.																																																																																															
LT _{LED}	LED Life Time	30,000	-	-	[Hour]	Note 4-4.																																																																																															
Symbol	Description	Min.	Typ.	Max.	Unit	Remark																																																																																															
I _s	LED String Current	-	120	132	[mA]	100% duty ratio of LED chip.																																																																																															
V _s	LED String Voltage	53.1	56.7	60.3	[Volt]	I _s =120mA @ 100% duty ratio. Note 4-1, Note 4-5.																																																																																															
ΔV _s	Maximum V _s Voltage Deviation of light bar	-	-	3.6	[Volt]	I _s =120mA @ 100% duty ratio. Note 4-2.																																																																																															
P _{LED}	LED Light Bar Power Consumption	-	27.2	28.9	[Watt]	Note 4-3.																																																																																															
LT _{LED}	LED Life Time	30,000	-	-	[Hour]	Note 4-4.																																																																																															
OVP	Over Voltage Protection in system board	110%	V _s max	-	[Volt]	Note 4-5.																																																																																															
		P34	NA	<h3>Add note 4-6</h3> <p>Note 4-6: AUO strongly recommend "Analog Dimming" method for backlight; brightness control for Wany Noise-Free. Otherwise, recommended Just Dimming Control Signal (PWM Signal) should be synchronized with Frame Frequency.</p>																																																																																																	

0.2	2014/12/02	P13	<h3>3.1 Block Diagram</h3>	<h3>3.1 Block Diagram</h3>																																																																																																																																																				
		P19	<h3>3.3.2 Recommended Operating Condition</h3> <table border="1"> <thead> <tr> <th>Symbol</th> <th>Description</th> <th>Min.</th> <th>Typ.</th> <th>Max.</th> <th>Unit</th> <th>Remark</th> </tr> </thead> <tbody> <tr> <td>VDD¹⁾</td> <td>Power supply Input voltage</td> <td>10.8</td> <td>12.0</td> <td>13.2</td> <td>[Volt]</td> <td></td> </tr> <tr> <td>IDD²⁾</td> <td>Power supply Input Current (max.)</td> <td>0.59</td> <td>0.7</td> <td>-</td> <td>[A]</td> <td>VDD=12.0V, Black Pattern, Fv=144Hz.</td> </tr> <tr> <td>PDD³⁾</td> <td>VDD Power Consumption</td> <td>7.0</td> <td>8.4</td> <td>-</td> <td>[Watt]</td> <td>VDD=12.0V, Black Pattern, Fv=144Hz.</td> </tr> <tr> <td>I_{Rush}⁴⁾</td> <td>Inrush Current</td> <td>-</td> <td>-</td> <td>3</td> <td>[A]</td> <td>Note 3-1)</td> </tr> <tr> <td>VDD_{rip}⁵⁾</td> <td>Allowable VDD Ripple Voltage</td> <td>-</td> <td>-</td> <td>500</td> <td>[mV]</td> <td>VDD=12.0V, Black Pattern, Fv=144Hz.</td> </tr> </tbody> </table>	Symbol	Description	Min.	Typ.	Max.	Unit	Remark	VDD ¹⁾	Power supply Input voltage	10.8	12.0	13.2	[Volt]		IDD ²⁾	Power supply Input Current (max.)	0.59	0.7	-	[A]	VDD=12.0V, Black Pattern, Fv=144Hz.	PDD ³⁾	VDD Power Consumption	7.0	8.4	-	[Watt]	VDD=12.0V, Black Pattern, Fv=144Hz.	I _{Rush} ⁴⁾	Inrush Current	-	-	3	[A]	Note 3-1)	VDD _{rip} ⁵⁾	Allowable VDD Ripple Voltage	-	-	500	[mV]	VDD=12.0V, Black Pattern, Fv=144Hz.	<h3>3.3.2 Recommended Operating Condition</h3> <table border="1"> <thead> <tr> <th>Symbol</th> <th>Description</th> <th>Min.</th> <th>Typ.</th> <th>Max.</th> <th>Unit</th> <th>Remark</th> </tr> </thead> <tbody> <tr> <td>VDD¹⁾</td> <td>Power supply Input voltage</td> <td>10.8</td> <td>12.0</td> <td>13.2</td> <td>[Volt]</td> <td></td> </tr> <tr> <td>IDD²⁾</td> <td>Power supply Input Current (max.)</td> <td>0.5</td> <td>1.3</td> <td>-</td> <td>[A]</td> <td>VDD=12.0V, Black Pattern, Fv=144Hz.</td> </tr> <tr> <td>PDD³⁾</td> <td>VDD Power Consumption</td> <td>6.5</td> <td>15.6</td> <td>-</td> <td>[Watt]</td> <td>VDD=12.0V, Black Pattern, Fv=144Hz.</td> </tr> <tr> <td>I_{Rush}⁴⁾</td> <td>Inrush Current</td> <td>-</td> <td>-</td> <td>3</td> <td>[A]</td> <td>Note 3-1)</td> </tr> <tr> <td>VDD_{rip}⁵⁾</td> <td>Allowable VDD Ripple Voltage</td> <td>-</td> <td>-</td> <td>500</td> <td>[mV]</td> <td>VDD=12.0V, Black Pattern, Fv=144Hz.</td> </tr> </tbody> </table>	Symbol	Description	Min.	Typ.	Max.	Unit	Remark	VDD ¹⁾	Power supply Input voltage	10.8	12.0	13.2	[Volt]		IDD ²⁾	Power supply Input Current (max.)	0.5	1.3	-	[A]	VDD=12.0V, Black Pattern, Fv=144Hz.	PDD ³⁾	VDD Power Consumption	6.5	15.6	-	[Watt]	VDD=12.0V, Black Pattern, Fv=144Hz.	I _{Rush} ⁴⁾	Inrush Current	-	-	3	[A]	Note 3-1)	VDD _{rip} ⁵⁾	Allowable VDD Ripple Voltage	-	-	500	[mV]	VDD=12.0V, Black Pattern, Fv=144Hz.																																																																
Symbol	Description	Min.	Typ.	Max.	Unit	Remark																																																																																																																																																		
VDD ¹⁾	Power supply Input voltage	10.8	12.0	13.2	[Volt]																																																																																																																																																			
IDD ²⁾	Power supply Input Current (max.)	0.59	0.7	-	[A]	VDD=12.0V, Black Pattern, Fv=144Hz.																																																																																																																																																		
PDD ³⁾	VDD Power Consumption	7.0	8.4	-	[Watt]	VDD=12.0V, Black Pattern, Fv=144Hz.																																																																																																																																																		
I _{Rush} ⁴⁾	Inrush Current	-	-	3	[A]	Note 3-1)																																																																																																																																																		
VDD _{rip} ⁵⁾	Allowable VDD Ripple Voltage	-	-	500	[mV]	VDD=12.0V, Black Pattern, Fv=144Hz.																																																																																																																																																		
Symbol	Description	Min.	Typ.	Max.	Unit	Remark																																																																																																																																																		
VDD ¹⁾	Power supply Input voltage	10.8	12.0	13.2	[Volt]																																																																																																																																																			
IDD ²⁾	Power supply Input Current (max.)	0.5	1.3	-	[A]	VDD=12.0V, Black Pattern, Fv=144Hz.																																																																																																																																																		
PDD ³⁾	VDD Power Consumption	6.5	15.6	-	[Watt]	VDD=12.0V, Black Pattern, Fv=144Hz.																																																																																																																																																		
I _{Rush} ⁴⁾	Inrush Current	-	-	3	[A]	Note 3-1)																																																																																																																																																		
VDD _{rip} ⁵⁾	Allowable VDD Ripple Voltage	-	-	500	[mV]	VDD=12.0V, Black Pattern, Fv=144Hz.																																																																																																																																																		
		P22																																																																																																																																																						
		P26	<h3>3.4.5 Input Timing Specification</h3> <table border="1"> <thead> <tr> <th>Symbol</th> <th>Description</th> <th>Min.</th> <th>Typ.</th> <th>Max.</th> <th>Unit</th> <th>Remark</th> </tr> </thead> <tbody> <tr> <td>T_v¹⁾</td> <td rowspan="3">Vertical Section</td> <td>Period</td> <td>1452</td> <td>1481</td> <td>2192</td> <td>Th</td> </tr> <tr> <td>t_{diso (v)}²⁾</td> <td>Active</td> <td>1440</td> <td>1440</td> <td>1440</td> <td>Th</td> </tr> <tr> <td>T_{bk (v)}³⁾</td> <td>Blanking</td> <td>12</td> <td>41</td> <td>752</td> <td>Th</td> </tr> <tr> <td>F_v⁴⁾</td> <td rowspan="3">Horizontal Section</td> <td>Frequency</td> <td>119</td> <td>144</td> <td>145</td> <td>Hz</td> </tr> <tr> <td>T_h⁵⁾</td> <td>Period</td> <td>345</td> <td>360</td> <td>521</td> <td>100ns</td> </tr> <tr> <td>t_{diso (h)}⁶⁾</td> <td>Active</td> <td>320</td> <td>320</td> <td>320</td> <td>100ns</td> </tr> <tr> <td>T_{bk (h)}⁷⁾</td> <td>Blanking</td> <td>25</td> <td>40</td> <td>201</td> <td>100ns</td> </tr> <tr> <td>F_h⁸⁾</td> <td>Frequency</td> <td>173</td> <td>213</td> <td>318</td> <td>KHz</td> <td>Note 3-3)</td> </tr> <tr> <td>T_{clk}⁹⁾</td> <td rowspan="2">LVDS Clock</td> <td>Period</td> <td>11.1</td> <td>13.0</td> <td>16.8</td> <td>ns</td> <td>1Fclk</td> </tr> <tr> <td>E_{clk}¹⁰⁾</td> <td>Frequency</td> <td>58</td> <td>76.8</td> <td>90</td> <td>MHz</td> <td>Note 3-4)</td> </tr> </tbody> </table>	Symbol	Description	Min.	Typ.	Max.	Unit	Remark	T _v ¹⁾	Vertical Section	Period	1452	1481	2192	Th	t _{diso (v)} ²⁾	Active	1440	1440	1440	Th	T _{bk (v)} ³⁾	Blanking	12	41	752	Th	F _v ⁴⁾	Horizontal Section	Frequency	119	144	145	Hz	T _h ⁵⁾	Period	345	360	521	100ns	t _{diso (h)} ⁶⁾	Active	320	320	320	100ns	T _{bk (h)} ⁷⁾	Blanking	25	40	201	100ns	F _h ⁸⁾	Frequency	173	213	318	KHz	Note 3-3)	T _{clk} ⁹⁾	LVDS Clock	Period	11.1	13.0	16.8	ns	1Fclk	E _{clk} ¹⁰⁾	Frequency	58	76.8	90	MHz	Note 3-4)	<h3>3.4.5 Input Timing Specification</h3> <table border="1"> <thead> <tr> <th>Symbol</th> <th>Description</th> <th>Min.</th> <th>Typ.</th> <th>Max.</th> <th>Unit</th> <th>Remark</th> </tr> </thead> <tbody> <tr> <td>T_v¹⁾</td> <td rowspan="3">Vertical Section</td> <td>Period</td> <td>1452</td> <td>1481</td> <td>2192</td> <td>Th</td> </tr> <tr> <td>t_{diso (v)}²⁾</td> <td>Active</td> <td>1440</td> <td>1440</td> <td>1440</td> <td>Th</td> </tr> <tr> <td>T_{bk (v)}³⁾</td> <td>Blanking</td> <td>12</td> <td>41</td> <td>752</td> <td>Th</td> </tr> <tr> <td>F_v⁴⁾</td> <td rowspan="3">Horizontal Section</td> <td>Frequency</td> <td>119</td> <td>144</td> <td>145</td> <td>Hz</td> <td>Note 3-3)</td> </tr> <tr> <td>T_h⁵⁾</td> <td>Period</td> <td>345</td> <td>360</td> <td>521</td> <td>100ns</td> </tr> <tr> <td>t_{diso (h)}⁶⁾</td> <td>Active</td> <td>320</td> <td>320</td> <td>320</td> <td>100ns</td> </tr> <tr> <td>T_{bk (h)}⁷⁾</td> <td>Blanking</td> <td>25</td> <td>40</td> <td>201</td> <td>100ns</td> </tr> <tr> <td>F_h⁸⁾</td> <td>Frequency</td> <td>59.7</td> <td>177.7</td> <td>250.6</td> <td>KHz</td> <td>Note 3-4)</td> </tr> <tr> <td>T_{clk}⁹⁾</td> <td rowspan="2">LVDS Clock</td> <td>Period</td> <td>11.1</td> <td>15.6</td> <td>39.9</td> <td>ns</td> <td>1Fclk</td> </tr> <tr> <td>E_{clk}¹⁰⁾</td> <td>Frequency</td> <td>25</td> <td>34</td> <td>20</td> <td>MHz</td> <td>Note 3-5)</td> </tr> </tbody> </table> <p>Note 3-3: The optimized setting is 119-1451 for driving for good picture quality.</p>	Symbol	Description	Min.	Typ.	Max.	Unit	Remark	T _v ¹⁾	Vertical Section	Period	1452	1481	2192	Th	t _{diso (v)} ²⁾	Active	1440	1440	1440	Th	T _{bk (v)} ³⁾	Blanking	12	41	752	Th	F _v ⁴⁾	Horizontal Section	Frequency	119	144	145	Hz	Note 3-3)	T _h ⁵⁾	Period	345	360	521	100ns	t _{diso (h)} ⁶⁾	Active	320	320	320	100ns	T _{bk (h)} ⁷⁾	Blanking	25	40	201	100ns	F _h ⁸⁾	Frequency	59.7	177.7	250.6	KHz	Note 3-4)	T _{clk} ⁹⁾	LVDS Clock	Period	11.1	15.6	39.9	ns	1Fclk	E _{clk} ¹⁰⁾	Frequency	25	34	20	MHz	Note 3-5)	
Symbol	Description	Min.	Typ.	Max.	Unit	Remark																																																																																																																																																		
T _v ¹⁾	Vertical Section	Period	1452	1481	2192	Th																																																																																																																																																		
t _{diso (v)} ²⁾		Active	1440	1440	1440	Th																																																																																																																																																		
T _{bk (v)} ³⁾		Blanking	12	41	752	Th																																																																																																																																																		
F _v ⁴⁾	Horizontal Section	Frequency	119	144	145	Hz																																																																																																																																																		
T _h ⁵⁾		Period	345	360	521	100ns																																																																																																																																																		
t _{diso (h)} ⁶⁾		Active	320	320	320	100ns																																																																																																																																																		
T _{bk (h)} ⁷⁾	Blanking	25	40	201	100ns																																																																																																																																																			
F _h ⁸⁾	Frequency	173	213	318	KHz	Note 3-3)																																																																																																																																																		
T _{clk} ⁹⁾	LVDS Clock	Period	11.1	13.0	16.8	ns	1Fclk																																																																																																																																																	
E _{clk} ¹⁰⁾		Frequency	58	76.8	90	MHz	Note 3-4)																																																																																																																																																	
Symbol	Description	Min.	Typ.	Max.	Unit	Remark																																																																																																																																																		
T _v ¹⁾	Vertical Section	Period	1452	1481	2192	Th																																																																																																																																																		
t _{diso (v)} ²⁾		Active	1440	1440	1440	Th																																																																																																																																																		
T _{bk (v)} ³⁾		Blanking	12	41	752	Th																																																																																																																																																		
F _v ⁴⁾	Horizontal Section	Frequency	119	144	145	Hz	Note 3-3)																																																																																																																																																	
T _h ⁵⁾		Period	345	360	521	100ns																																																																																																																																																		
t _{diso (h)} ⁶⁾		Active	320	320	320	100ns																																																																																																																																																		
T _{bk (h)} ⁷⁾	Blanking	25	40	201	100ns																																																																																																																																																			
F _h ⁸⁾	Frequency	59.7	177.7	250.6	KHz	Note 3-4)																																																																																																																																																		
T _{clk} ⁹⁾	LVDS Clock	Period	11.1	15.6	39.9	ns	1Fclk																																																																																																																																																	
E _{clk} ¹⁰⁾		Frequency	25	34	20	MHz	Note 3-5)																																																																																																																																																	
		P30	<h3>3.5 Power ON/OFF Sequence</h3> <table border="1"> <thead> <tr> <th>Symbol</th> <th>Value</th> <th>Unit</th> <th>Remark</th> </tr> </thead> <tbody> <tr> <td>T1</td> <td>0.5</td> <td>ms</td> <td>10</td> </tr> <tr> <td>T2</td> <td>0</td> <td>ms</td> <td>50</td> </tr> <tr> <td>T3</td> <td>500</td> <td>ms</td> <td>-</td> </tr> <tr> <td>T4</td> <td>100</td> <td>ms</td> <td>-</td> </tr> <tr> <td>T5</td> <td>0</td> <td>ms</td> <td>50</td> </tr> <tr> <td>T6</td> <td>0</td> <td>ms</td> <td>150</td> </tr> <tr> <td>T7</td> <td>1000</td> <td>ms</td> <td>-</td> </tr> </tbody> </table>	Symbol	Value	Unit	Remark	T1	0.5	ms	10	T2	0	ms	50	T3	500	ms	-	T4	100	ms	-	T5	0	ms	50	T6	0	ms	150	T7	1000	ms	-	<h3>3.5 Power ON/OFF Sequence</h3> <table border="1"> <thead> <tr> <th>Symbol</th> <th>Value</th> <th>Unit</th> <th>Remark</th> </tr> </thead> <tbody> <tr> <td>T1</td> <td>0.5</td> <td>ms</td> <td>13</td> </tr> <tr> <td>T2</td> <td>0</td> <td>ms</td> <td>53</td> </tr> <tr> <td>T3</td> <td>500</td> <td>ms</td> <td>-</td> </tr> <tr> <td>T4</td> <td>100</td> <td>ms</td> <td>-</td> </tr> <tr> <td>T5</td> <td>0</td> <td>ms</td> <td>53</td> </tr> <tr> <td>T6</td> <td>0</td> <td>ms</td> <td>-</td> </tr> <tr> <td>T7</td> <td>1000</td> <td>ms</td> <td>-</td> </tr> </tbody> </table>	Symbol	Value	Unit	Remark	T1	0.5	ms	13	T2	0	ms	53	T3	500	ms	-	T4	100	ms	-	T5	0	ms	53	T6	0	ms	-	T7	1000	ms	-																																																																																				
Symbol	Value	Unit	Remark																																																																																																																																																					
T1	0.5	ms	10																																																																																																																																																					
T2	0	ms	50																																																																																																																																																					
T3	500	ms	-																																																																																																																																																					
T4	100	ms	-																																																																																																																																																					
T5	0	ms	50																																																																																																																																																					
T6	0	ms	150																																																																																																																																																					
T7	1000	ms	-																																																																																																																																																					
Symbol	Value	Unit	Remark																																																																																																																																																					
T1	0.5	ms	13																																																																																																																																																					
T2	0	ms	53																																																																																																																																																					
T3	500	ms	-																																																																																																																																																					
T4	100	ms	-																																																																																																																																																					
T5	0	ms	53																																																																																																																																																					
T6	0	ms	-																																																																																																																																																					
T7	1000	ms	-																																																																																																																																																					
		P38 P39	opening SPEC 2D Drawing 標示為 601.6*337.91mm	修正, 3 opening SPEC 2D Drawing 標示為 601.6*340.15mm 新增 COF 寬度																																																																																																																																																				
1.0		P 7	<h3>2.1 Display Characteristics</h3> <table border="1"> <thead> <tr> <th>Power Consumption (LCD Module + Backlight unit)</th> <th>Value</th> <th>Unit</th> <th>Remark</th> </tr> </thead> <tbody> <tr> <td>P_{max}</td> <td>94.3 (Typ.)</td> <td>Watt</td> <td>LCD module: PDD (Typ.)=6.2 @ Black pattern, Fv=144Hz. Backlight unit: P_{back} (Typ.)=27.2 @ I_{back}=120mA.</td> </tr> </tbody> </table>	Power Consumption (LCD Module + Backlight unit)	Value	Unit	Remark	P _{max}	94.3 (Typ.)	Watt	LCD module: PDD (Typ.)=6.2 @ Black pattern, Fv=144Hz. Backlight unit: P _{back} (Typ.)=27.2 @ I _{back} =120mA.	<h3>2.1 Display Characteristics</h3> <table border="1"> <thead> <tr> <th>Power Consumption (LCD Module + Backlight unit)</th> <th>Value</th> <th>Unit</th> <th>Remark</th> </tr> </thead> <tbody> <tr> <td>P_{max}</td> <td>83.7 (Typ.)</td> <td>Watt</td> <td>LCD module: PDD (Typ.)=6.5 @ Black pattern, Fv=144Hz. Backlight unit: P_{back} (Typ.)=27.2 @ I_{back}=120mA.</td> </tr> </tbody> </table>	Power Consumption (LCD Module + Backlight unit)	Value	Unit	Remark	P _{max}	83.7 (Typ.)	Watt	LCD module: PDD (Typ.)=6.5 @ Black pattern, Fv=144Hz. Backlight unit: P _{back} (Typ.)=27.2 @ I _{back} =120mA.																																																																																																																																				
Power Consumption (LCD Module + Backlight unit)	Value	Unit	Remark																																																																																																																																																					
P _{max}	94.3 (Typ.)	Watt	LCD module: PDD (Typ.)=6.2 @ Black pattern, Fv=144Hz. Backlight unit: P _{back} (Typ.)=27.2 @ I _{back} =120mA.																																																																																																																																																					
Power Consumption (LCD Module + Backlight unit)	Value	Unit	Remark																																																																																																																																																					
P _{max}	83.7 (Typ.)	Watt	LCD module: PDD (Typ.)=6.5 @ Black pattern, Fv=144Hz. Backlight unit: P _{back} (Typ.)=27.2 @ I _{back} =120mA.																																																																																																																																																					
		P26	<h3>3.4.5 Input Timing Specification</h3> <p>Note 3-5: The equation is listed as following. Please don't exceed the above recommended value.</p> <p>F_{clk} (Min.) = F_v (Min.) × Th (Min.) × Tv (Min.) F_{clk} (Typ.) = F_v (Typ.) × Th (Typ.) × Tv (Typ.) F_{clk} (Max.) = F_v (Max.) × Th (Max.) × Tv (Max.)</p>	<h3>3.4.5 Input Timing Specification</h3> <p>Note 3-5: The equation is listed as following. Please don't exceed the above recommended value.</p> <p>F_{clk} (Min.) = F_v (Typ.) × Th (Typ.) × Tv (Typ.) F_{clk} (Max.) = F_v (Th) × Tv × F_{clk} (Max.)</p>																																																																																																																																																				

1 Handling Precautions

- 1) Since front polarizer is easily damaged, pay attention not to scratch it.
- 2) Be sure to turn off power supply when inserting or disconnecting from input connector.
- 3) Wipe off water drop immediately. Long contact with water may cause discoloration or spots.
- 4) When the panel surface is soiled, wipe it with absorbent cotton or other soft cloth.
- 5) Since the panel is made of glass, it may break or crack if dropped or bumped on hard surface.
- 6) Since CMOS LSI is used in this module, take care of static electricity and insure human earth when handling.
- 7) Do not open or modify the Module Assembly.
- 8) Do not press the reflector sheet at the back of the module to any directions.
- 9) In case a TFT-LCD Module has to be put back into the packing container slot after once it was taken out from the container, do not press the center of the LED lightbar edge. Otherwise the TFT-LCD Module may be damaged.
- 10) Insert or pull out the interface connector, be sure not to rotate nor tilt it of the TFT-LCD Module.
- 11) Do not twist nor bend the TFT -LCD Module even momentary. It should be taken into consideration that no bending/twisting forces are applied to the TFT-LCD Module from outside. Otherwise the TFT-LCD Module may be damaged.
- 12) Please avoid touching COF position while you are doing mechanical design.
- 13) When storing modules as spares for a long time, the following precaution is necessary:
Store them in a dark place. Do not expose the module to sunlight or fluorescent light. Keep the temperature between 5 and 35 at normal humidity.

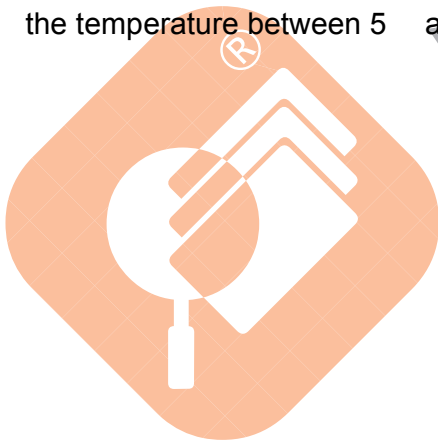

2 General Description

This specification applies to the 27 inch wide Color a-Si TFT-LCD Module M270DTN01.0. The display supports the QHD - 2560(H) x 1440(V) screen format and 16.7M colors (RGB 8-bit data). The input interface is 8 port LVDS and this module doesn't contain an driver board for backlight.

2.1 Display Characteristics

The following items are characteristics summary on the table under 25 condition:

ITEMS	Unit	SPECIFICATIONS
Screen Diagonal	[mm]	684.67 (27")
Active Area	[mm]	596.74 (H) x 335.66 (V)
Pixels H x V	-	2560(x3) x 1440
Pixel Pitch	[um]	233.1 (per one triad) ×233.1
Pixel Arrangement	-	R.G.B. Vertical Stripe
Display Mode	-	TN Mode, Normally White
White Luminance (Center)	[cd/m ²]	350 (Typ.)
Contrast Ratio	-	1000 (Typ.)
Response Time	[msec]	5 (Typ., on/off)
Power Consumption (LCD Module + Backligh unit)	[Watt]	33.7 (Typ.) LCD module : PDD (Typ.)=6.5 @ Black pattern,Fv=144Hz Backlight unit : P _{BLU} (Typ.) =27.2 @Is=120mA
Weight	[Grams]	2200
Outline Dimension	[mm]	613.6(H) × 356.85(V) × 10.4(D) Typ.
Electrical Interface	-	8 port LVDS
Support Color	-	16.7M colors (RGB 8-bits)
Surface Treatment	-	Anti-Glare, 3H
Temperature Range		
Operating	[°C]	0 to +50
Storage (Shipping)	[°C]	-20 to +60
RoHS Compliance	-	RoHS Compliance
TCO Compliance	-	TCO 6.0 Compliance

2.2 Absolute Maximum Rating of Environment

Permanent damage may occur if exceeding the following maximum rating.

Symbol	Description	Min.	Max.	Unit	Remark
TOP	Operating Temperature	0	+50	[°C]	Note 2-1
TGS	Glass surface temperature (operation)	0	+65	[°C]	Note 2-1 Function judged only
HOP	Operation Humidity	5	90	[%RH]	Note 2-1
TST	Storage Temperature	-20	+60	[°C]	
HST	Storage Humidity	5	90	[%RH]	

Note 2-1: Temperature and relative humidity range are shown as the below figure.

1. 90% RH Max (Ta 39)
2. Max wet-bulb temperature at 39 or less. (Ta 39)
3. No condensation

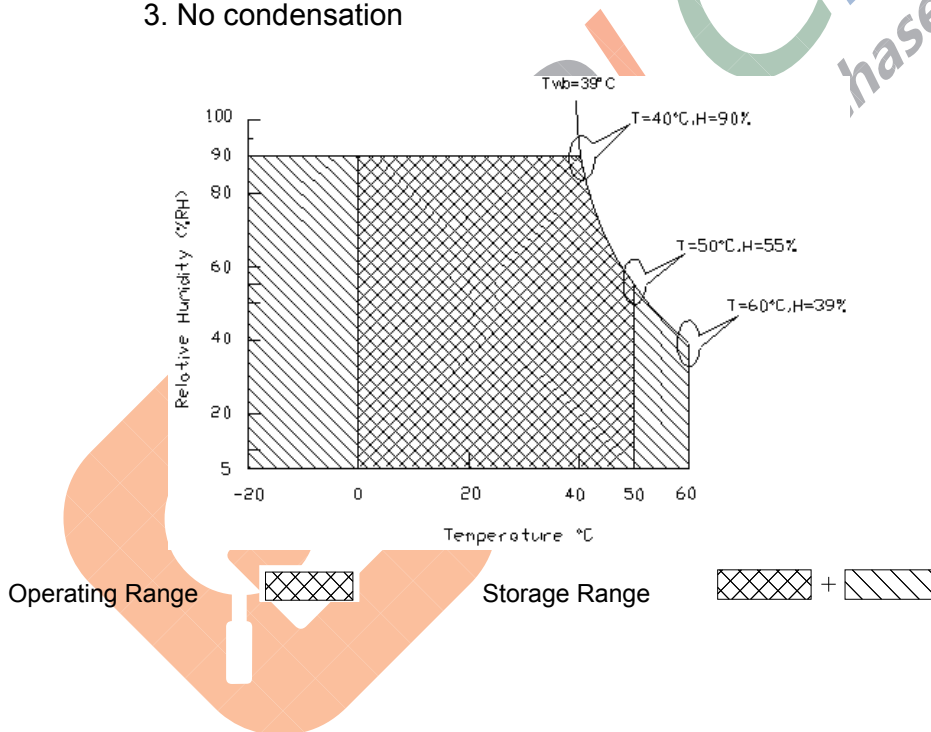

2.3 Optical Characteristics

The optical characteristics are measured on the following test condition.

Test Condition:

1. Equipment setup: Please refer to **Note 2-2**.
2. Panel Lighting time: 30 minutes
3. VDD=12.0V, Fv=144Hz, Is=120mA, Ta=25

Symbol	Description		Min.	Typ.	Max.	Unit	Remark			
L _w	White Luminance (Center of screen)		300	350	-	[cd/m ²]	Note 2-2 By SR-3			
L _{uni}	Luminance Uniformity (9 points)		75	80	-	[%]	Note 2-3 By SR-3			
CR	Contrast Ratio (Center of screen)		600	1000	-	-	Note 2-4 By SR-3			
θ _R	Horizontal Viewing Angle (CR=10)	Right	75	85	-	[degree]	Note 2-5 By SR-3			
θ _L		Left	75	85	-					
Φ _H	Vertical Viewing Angle (CR=10)	Up	70	80	-					
Φ _L		Down	70	80	-					
θ _R	Horizontal Viewing Angle (CR=5)	Right	75	88	-					
θ _L		Left	75	88	-					
Φ _H	Vertical Viewing Angle (CR=5)	Up	70	85	-					
Φ _L		Down	70	85	-					
T _R	Response Time	Rising Time	-	3.5	5.5	[msec]	Note 2-6 By TRD-100			
T _F		Falling Time	-	1.5	2.5					
-		Rising + Falling	-	5	8					
R _x	Color Coordinates (CIE 1931)	Red x	0.620	0.650	0.680	-	By SR-3			
R _y		Red y	0.308	0.338	0.368					
G _x		Green x	0.283	0.313	0.343					
G _y		Green y	0.596	0.626	0.656					
B _x		Blue x	0.120	0.150	0.180					
B _y		Blue y	0.022	0.052	0.082					
W _x		White x	0.283	0.313	0.343					
W _y		White y	0.299	0.329	0.359					
CT		Crosstalk		-	-			1.5	[%]	Note 2-7 By SR-3
F _{dB}		Flicker (Center of screen)		-	-			-20	[dB]	Note 2-8 By SR-3

Note 2-2: Equipment setup :

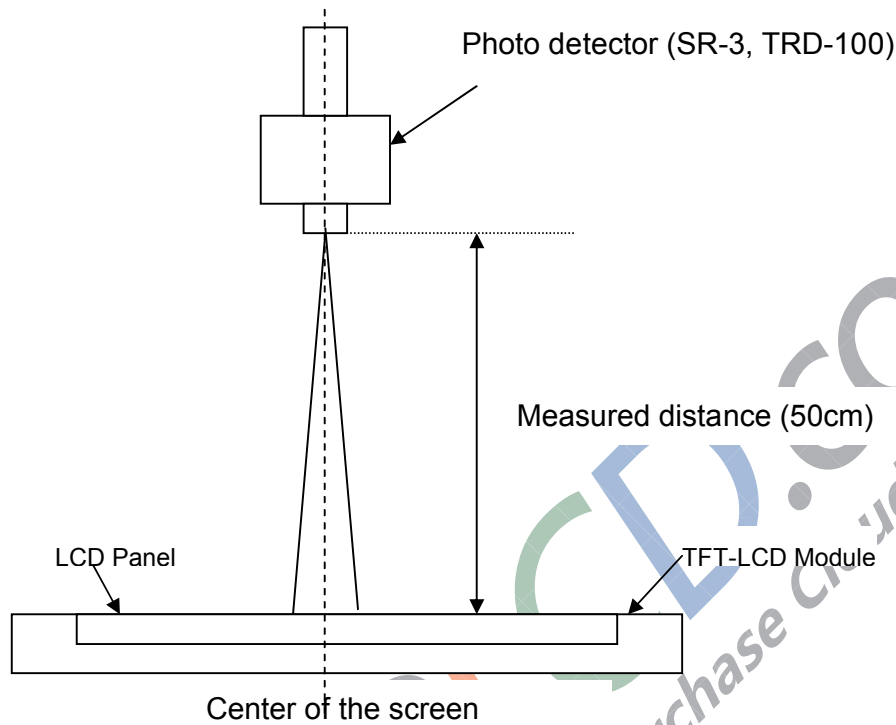

Note 2-3: Luminance Uniformity Measurement

Definition:

$$\text{Luminance Uniformity} = \frac{\text{Minimum Luminance of 9 Points (P1 ~ P9)}}{\text{Maximum Luminance of 9 Points (P1 ~ P9)}}$$

a. Test pattern: White Pattern

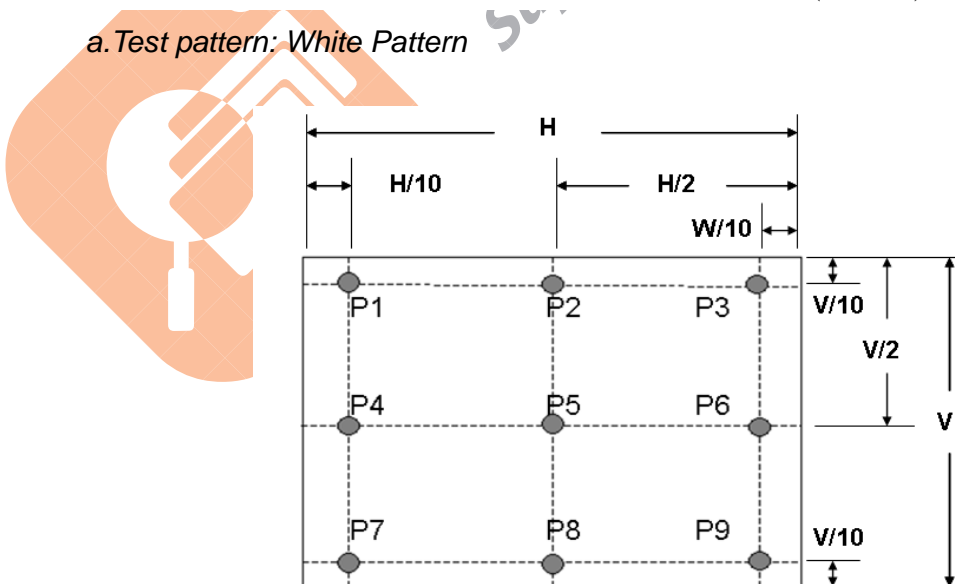

Note 2-4: Contrast Ratio Measurement

Definition:

$$\text{Contrast Ratio} = \frac{\text{Luminance of White pattern}}{\text{Luminance of Black pattern}}$$

- a. Measured position: Center of screen (P5) & perpendicular to the screen ($\theta = \phi = 0^\circ$)

Note 2-5: Viewing angle measurement

Definition: The angle at which the contrast ratio is greater than 10 & 5.

- a. Horizontal view angle: Divide to left & right (θ_L & θ_R)
Vertical view angle: Divide to up & down (ϕ_H & ϕ_L)

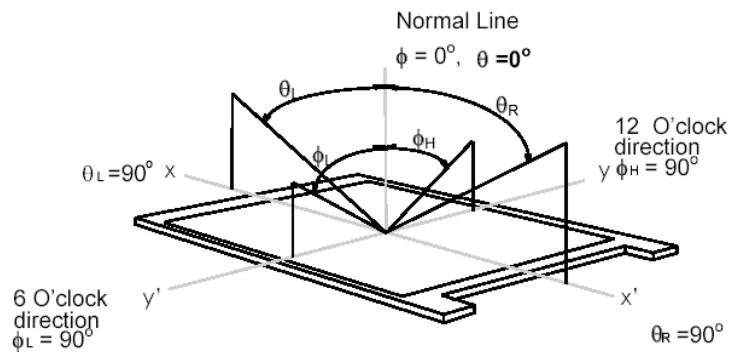

Note 2-6: Response time measurement

The output signals of photo detector are measured when the input signals are changed from “Black” to “White” (rising time, T_R), and from “White” to “Black” (falling time, T_F), respectively. The response time is interval between the 10% and 90% of optical response. (*Black & White color definition: Please refer section 3.4.3*)

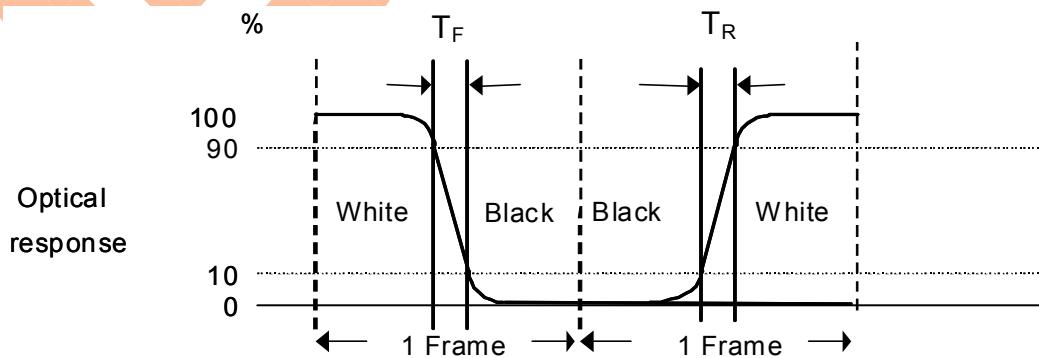

Note 2-7: Crosstalk measurement
Definition:

$$CT = \text{Max.} (CT_H, CT_V);$$

Where

a. Maximum Horizontal Crosstalk :

$$CT_H = \text{Max.} (| Y_{BL} - Y_{AL} | / Y_{AL} \times 100 \%, | Y_{BR} - Y_{AR} | / Y_{AR} \times 100 \%);$$

Maximum Vertical Crosstalk:

$$CT_V = \text{Max.} (| Y_{BU} - Y_{AU} | / Y_{AU} \times 100 \%, | Y_{BD} - Y_{AD} | / Y_{AD} \times 100 \%);$$

 b. $Y_{AU}, Y_{AD}, Y_{AL}, Y_{AR}$ = Luminance of measured location without Black pattern

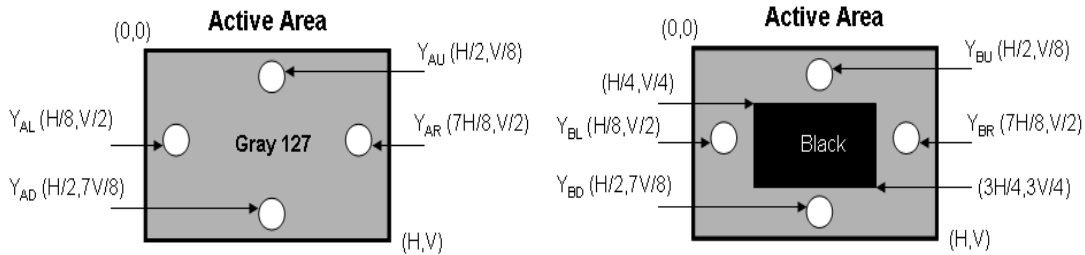
 $Y_{BU}, Y_{BD}, Y_{BL}, Y_{BR}$ = Luminance of measured location with Black pattern

Note 2-8: Flicker measurement

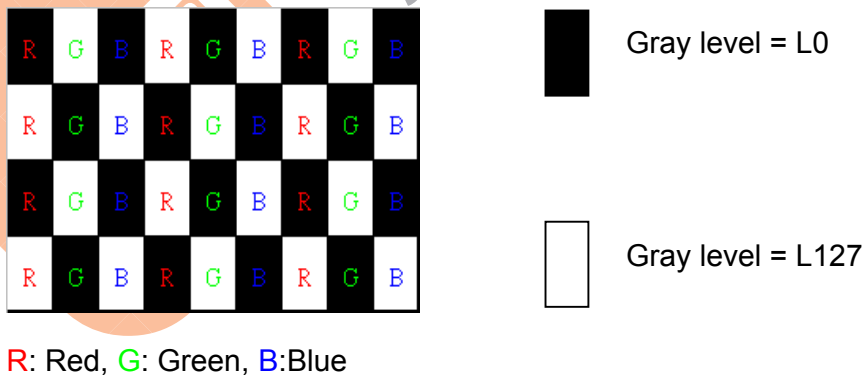
a. Test pattern: It is listed as following.

 b. Measured position: Center of screen (P5) & perpendicular to the screen ($\theta = \Phi = 0^\circ$)

3 TFT-LCD Module

3.1 Block Diagram

The following shows the block diagram of the 27 inch Color TFT-LCD Module.

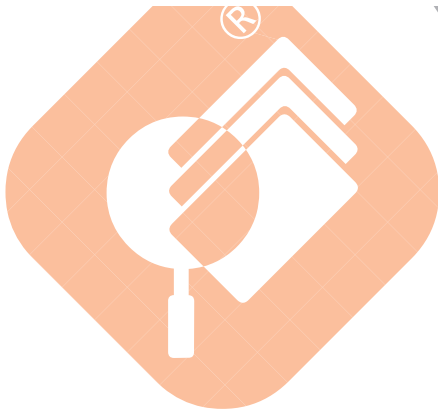
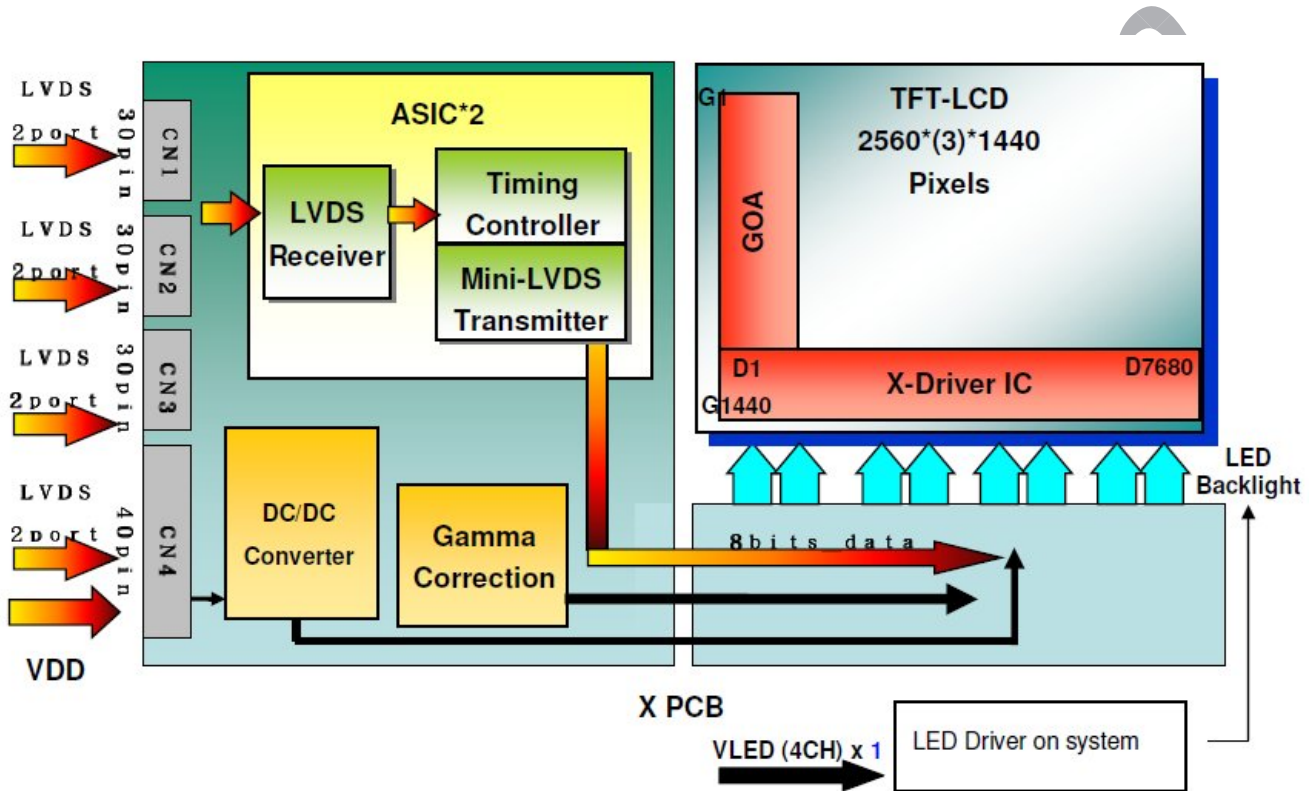

SUP

3.2 Interface Connection

3.2.1 Connector Type

TFT-LCD Connector	Manufacturer	STM	Starconn
	Part Number	MSCKT2407P30HB (CN1 / CN2 / CN3)	115F40-R000RA-M3 (CN4)
Mating Connector	Manufacturer	STM or compatible	JAE or compatible
	Part Number	PK2407P30V	FI-NX40HL

3.2.2 Connector Pin Assignment

CN 1

PIN #	Symbol	Description	Remark
1	R1 0N	Negative LVDS differential data input (Port1 data)	
2	R1 0P	Positive LVDS differential data input (Port1 data)	
3	R1 1N	Negative LVDS differential data input (Port1 data)	
4	R1 1P	Positive LVDS differential data input (Port1 data)	
5	R1 2N	Negative LVDS differential data input (Port1 data)	
6	R1 2P	Positive LVDS differential data input (Port1 data)	
7	GND	Ground	
8	R1 CLKN	Negative LVDS differential clock input (Port1 clock)	
9	R1 CLKP	Positive LVDS differential clock input (Port1 clock)	
10	GND	Ground	
11	R1 3N	Negative LVDS differential data input (Port1 data)	
12	R1 3P	Positive LVDS differential data input (Port1 data)	
13	NC	No connection (for AUO test only. Do not connect)	
14	NC	No connection (for AUO test only. Do not connect)	
15	GND	Ground	
16	R2 0N	Negative LVDS differential data input (Port2 data)	
17	R2 0P	Positive LVDS differential data input (Port2 data)	
18	R2 1N	Negative LVDS differential data input (Port2 data)	
19	R2 1P	Positive LVDS differential data input (Port2 data)	
20	R2 2N	Negative LVDS differential data input (Port2 data)	
21	R2 2P	Positive LVDS differential data input (Port2 data)	
22	GND	Ground	
23	R2 CLKN	Negative LVDS differential clock input (Port2 clock)	
24	R2 CLKP	Positive LVDS differential clock input (Port2 clock)	
25	GND	Ground	



26	R2_3N	Negative LVDS differential data input (Port2 data)	
27	R2_3P	Positive LVDS differential data input (Port2 data)	
28	NC	No connection (for AUO test only. Do not connect)	
29	NC	No connection (for AUO test only. Do not connect)	
30	NC	No connection (for AUO test only. Do not connect)	

CN 2

PIN #	Symbol	Description	Remark
1	R3_0N	Negative LVDS differential data input (Port3 data)	
2	R3_0P	Positive LVDS differential data input (Port3 data)	
3	R3_1N	Negative LVDS differential data input (Port3 data)	
4	R3_1P	Positive LVDS differential data input (Port3 data)	
5	R3_2N	Negative LVDS differential data input (Port3 data)	
6	R3_2P	Positive LVDS differential data input (Port3 data)	
7	GND	Ground	
8	R3_CLKN	Negative LVDS differential clock input (Port3 clock)	
9	R3_CLKP	Positive LVDS differential clock input (Port3 clock)	
10	GND	Ground	
11	R3_3N	Negative LVDS differential data input (Port3 data)	
12	R3_3P	Positive LVDS differential data input (Port3 data)	
13	NC	No connection (for AUO test only. Do not connect)	
14	NC	No connection (for AUO test only. Do not connect)	
15	GND	Ground	
16	R4_0N	Negative LVDS differential data input (Port4 data)	
17	R4_0P	Positive LVDS differential data input (Port4 data)	
18	R4_1N	Negative LVDS differential data input (Port4 data)	
19	R4_1P	Positive LVDS differential data input (Port4 data)	
20	R4_2N	Negative LVDS differential data input (Port4 data)	
21	R4_2P	Positive LVDS differential data input (Port4 data)	
22	GND	Ground	
23	R4_CLKN	Negative LVDS differential clock input (Port4 clock)	
24	R4_CLKP	Positive LVDS differential clock input (Port4 clock)	
25	GND	Ground	
26	R4_3N	Negative LVDS differential data input (Port4 data)	
27	R4_3P	Positive LVDS differential data input (Port4 data)	
28	NC	No connection (for AUO test only. Do not connect)	
29	NC	No connection (for AUO test only. Do not connect)	
30	Polarity_SYNC	Polarity_SYNC (O)	



CN 3

PIN #	Symbol	Description	Remark
1	R5_0N	Negative LVDS differential data input (Port5 data)	
2	R5_0P	Positive LVDS differential data input (Port5 data)	
3	R5_1N	Negative LVDS differential data input (Port5 data)	
4	R5_1P	Positive LVDS differential data input (Port5 data)	
5	R5_2N	Negative LVDS differential data input (Port5 data)	
6	R5_2P	Positive LVDS differential data input (Port5 data)	
7	GND	Ground	
8	R5_CLKN	Negative LVDS differential clock input (Port5 clock)	
9	R5_CLKP	Positive LVDS differential clock input (Port5 clock)	
10	GND	Ground	
11	R5_3N	Negative LVDS differential data input (Port5 data)	
12	R5_3P	Positive LVDS differential data input (Port5 data)	
13	NC	No connection (for AUO test only. Do not connect)	
14	NC	No connection (for AUO test only. Do not connect)	
15	GND	Ground	
16	R6_0N	Negative LVDS differential data input (Port6 data)	
17	R6_0P	Positive LVDS differential data input (Port6 data)	
18	R6_1N	Negative LVDS differential data input (Port6 data)	
19	R6_1P	Positive LVDS differential data input (Port6 data)	
20	R6_2N	Negative LVDS differential data input (Port6 data)	
21	R6_2P	Positive LVDS differential data input (Port6 data)	
22	GND	Ground	
23	R6_CLKN	Negative LVDS differential clock input (Port6 clock)	
24	R6_CLKP	Positive LVDS differential clock input (Port6 clock)	
25	GND	Ground	
26	R6_3N	Negative LVDS differential data input (Port6 data)	
27	R6_3P	Positive LVDS differential data input (Port6 data)	
28	NC	No connection (for AUO test only. Do not connect)	
29	NC	No connection (for AUO test only. Do not connect)	
30	3D_EN	3D_EN (I)	



CN 4

PIN #	Symbol	Description	Remark
1	R7 0N	Negative LVDS differential data input (Port7 data)	
2	R7 0P	Positive LVDS differential data input (Port7 data)	
3	R7 1N	Negative LVDS differential data input (Port7 data)	
4	R7 1P	Positive LVDS differential data input (Port7 data)	
5	R7 2N	Negative LVDS differential data input (Port7 data)	
6	R7 2P	Positive LVDS differential data input (Port7 data)	
7	GND	Ground	
8	R7 CLKN	Negative LVDS differential clock input (Port7 clock)	
9	R7 CLKP	Positive LVDS differential clock input (Port7 clock)	
10	GND	Ground	
11	R7 3N	Negative LVDS differential data input (Port7 data)	
12	R7 3P	Positive LVDS differential data input (Port7 data)	
13	NC	No connection (for AUO test only. Do not connect)	
14	NC	No connection (for AUO test only. Do not connect)	
15	GND	Ground	
16	R8 0N	Negative LVDS differential data input (Port8 data)	
17	R8 0P	Positive LVDS differential data input (Port8 data)	
18	R8 1N	Negative LVDS differential data input (Port8 data)	
19	R8 1P	Positive LVDS differential data input (Port8 data)	
20	R8 2N	Negative LVDS differential data input (Port8 data)	
21	R8 2P	Positive LVDS differential data input (Port8 data)	
22	GND	Ground	
23	R8 CLKN	Negative LVDS differential clock input (Port8 clock)	
24	R8 CLKP	Positive LVDS differential clock input (Port8 clock)	
25	GND	Ground	
26	R8 3N	Negative LVDS differential data input (Port8 data)	
27	R8 3P	Positive LVDS differential data input (Port8 data)	
28	NC	No connection (for AUO test only. Do not connect)	
29	NC	No connection (for AUO test only. Do not connect)	
30	NC	No connection (for AUO test only. Do not connect)	
31	NC	No connection (for AUO test only. Do not connect)	
32	NC	No connection (for AUO test only. Do not connect)	
33	NC	No connection (for AUO test only. Do not connect)	
34	GND	Ground	
35	GND	Ground	
36	NC	No connection (for AUO test only. Do not connect)	

37	VDD	Power Supply Input Voltage	
38	VDD	Power Supply Input Voltage	
39	VDD	Power Supply Input Voltage	
40	VDD	Power Supply Input Voltage	

com
#form

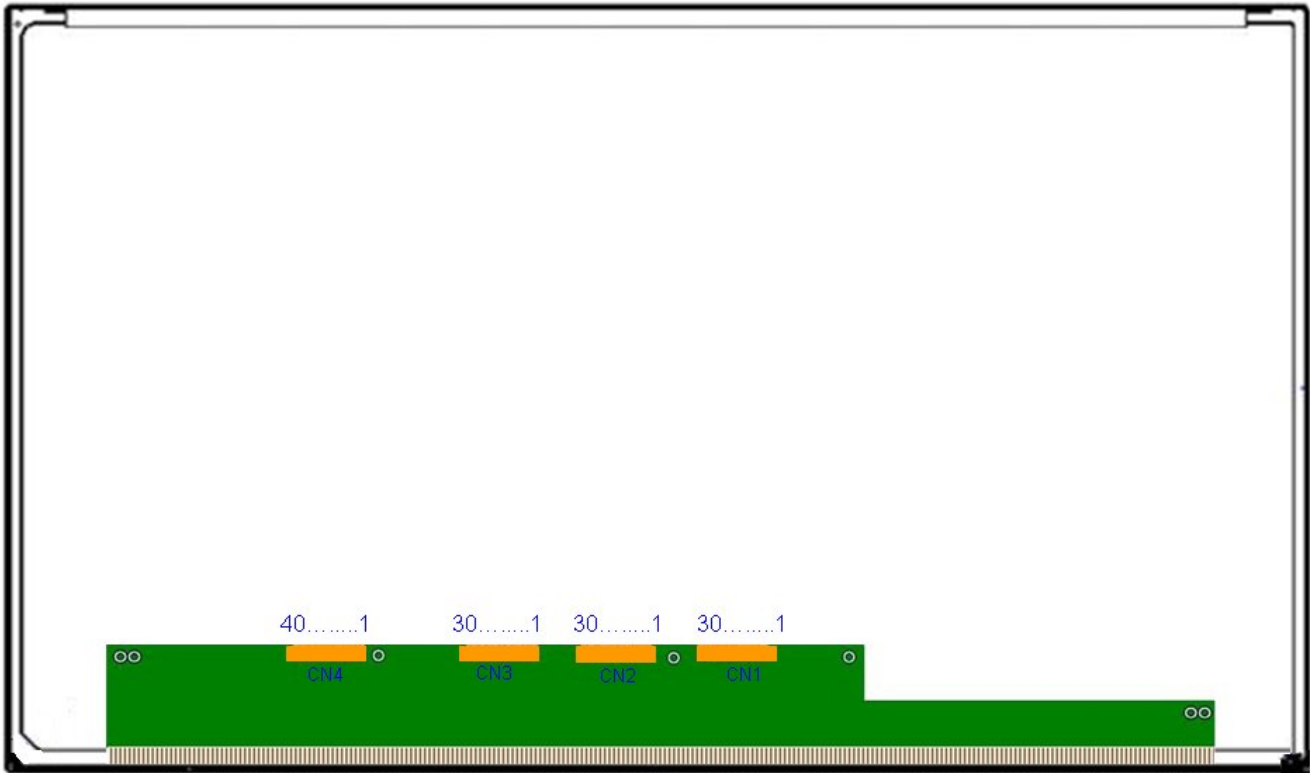

3.3 Electrical Characteristics

3.3.1 Absolute Maximum Rating

Permanent damage may occur if exceeding the following maximum rating.

Symbol	Description	Min	Max	Unit	Remark
VDD	Power Supply Input Voltage	GND-0.3	14	[Volt]	Ta=25

3.3.2 Recommended Operating Condition

Symbol	Description	Min	Typ	Max	Unit	Remark
VDD	Power supply Input voltage	10.8	12.0	13.2	[Volt]	
IDD	Power supply Input Current (RMS)		0.5	1.3	[A]	VDD= 12.0V, Black Pattern, Fv=144Hz
PDD	VDD Power Consumption		6.5	15.6	[Watt]	VDD= 12.0V, Black Pattern, Fv=144Hz
IRush	Inrush Current			3	[A]	Note 3-1
VDDrp	Allowable VDD Ripple Voltage	-	-	500	[mV]	VDD= 12.0V, Black Pattern, Fv=144Hz

Note 3-1: Inrush Current measurement:

Test circuit:

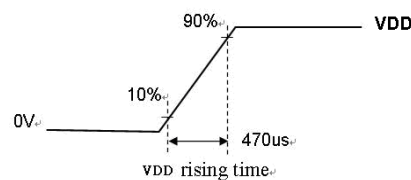
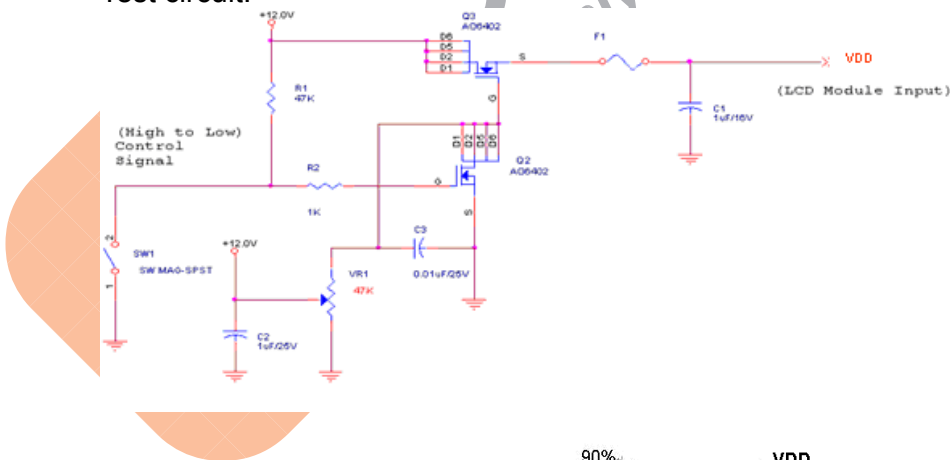

The duration of VDD rising time: 470us.

3.4 Signal Characteristics

3.4.1 LCD Pixel Format

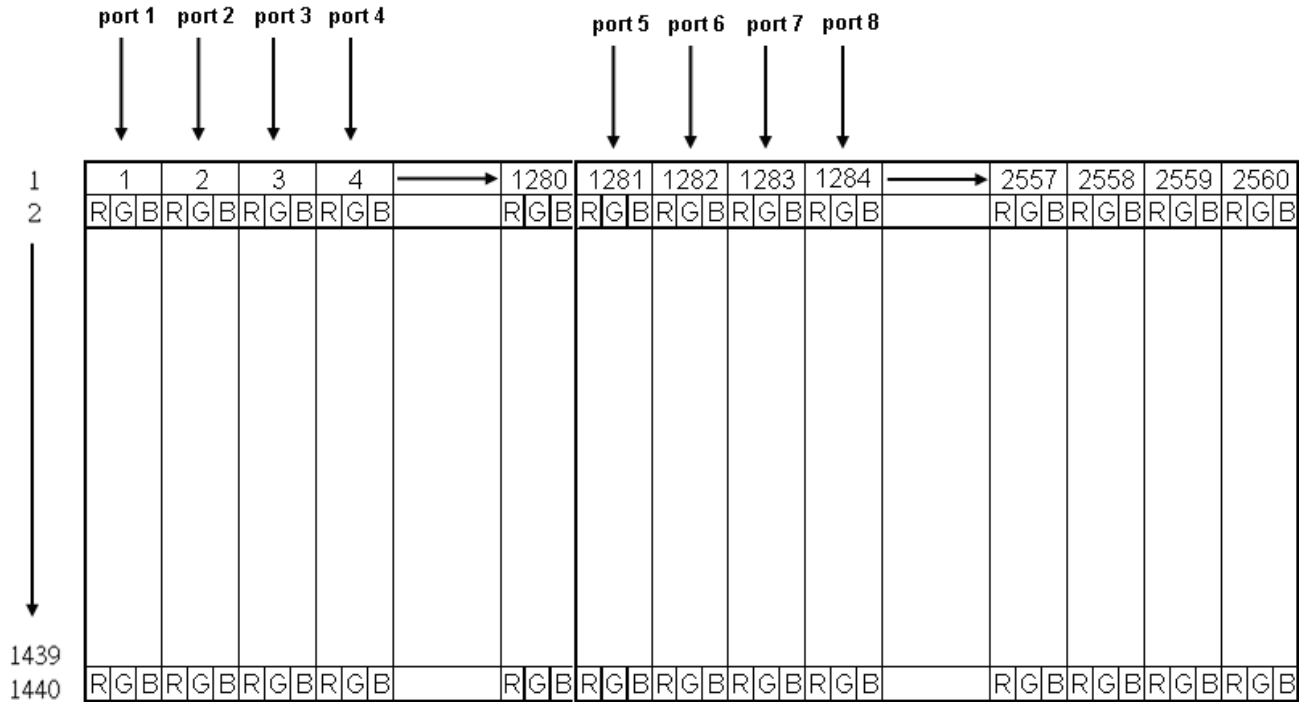

Note 3-2: The module use 8 port-LVDS interface.

Port 1 : $4N+1$ $N=0, \sim 319$ (1,5.. 1277pixel)

Port 2 : $4N+2$ $N=0, \sim 319$ (2,6.. 1278pixel)

Port 3 : $4N+3$ $N=0, \sim 319$ (3,7.. 1279pixel)

Port 4 : $4N+4$ $N=0, \sim 319$ (4,8.. 1280pixel)

Port 5 : $4N+1281$ $N=0, \sim 319$ (1281,1285.. 2557pixel)

Port 6 : $4N+1282$ $N=0, \sim 319$ (1282,1286.. 2558pixel)

Port 7 : $4N+1283$ $N=0, \sim 319$ (1283,1287.. 2559pixel)

Port 8 : $4N+1284$ $N=0, \sim 319$ (1284,1288.. 2560pixel)

3.4.2 LVDS Data Format

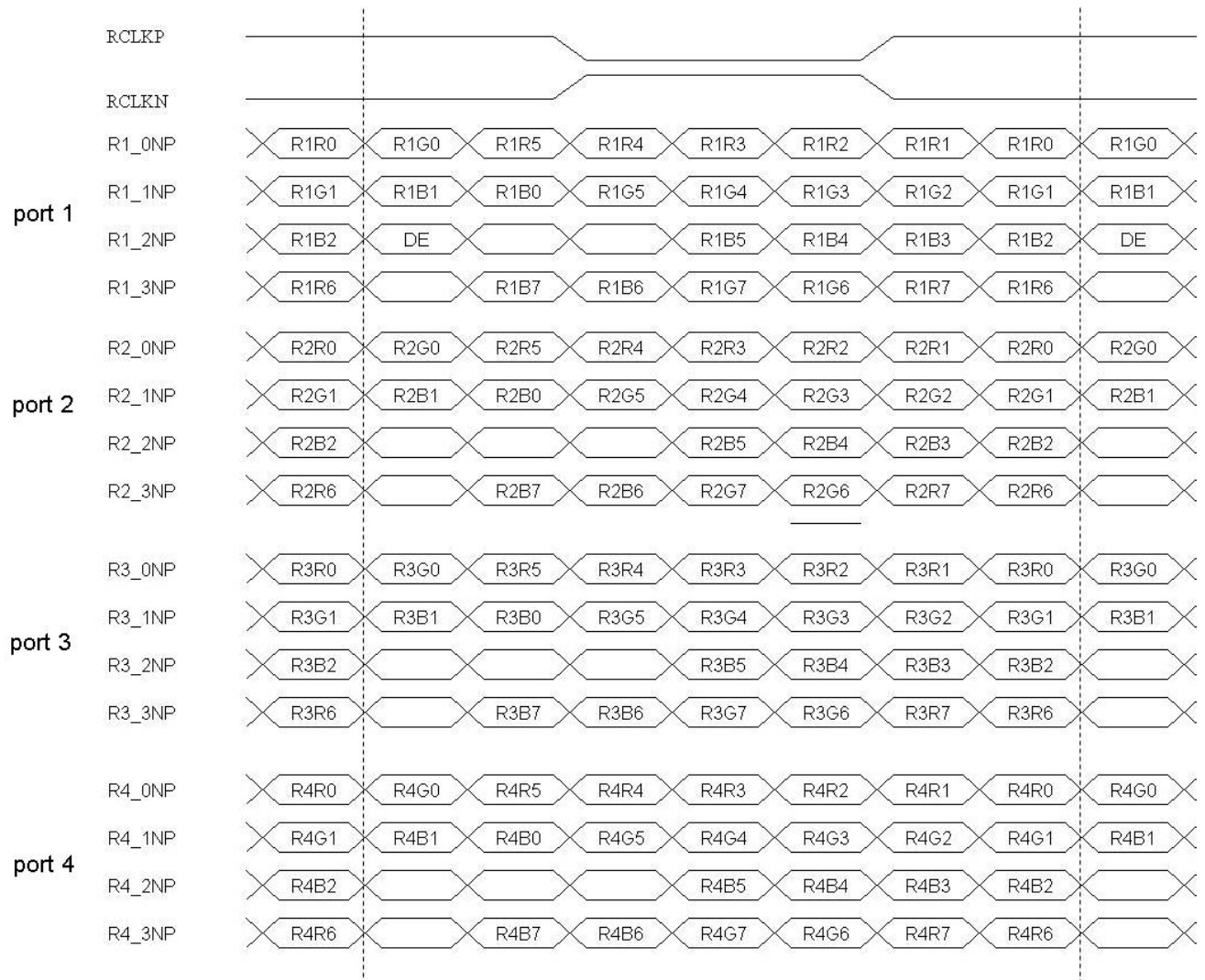



Product Specification

M270DTN01.0

AU OPTRONICS CORPORATION

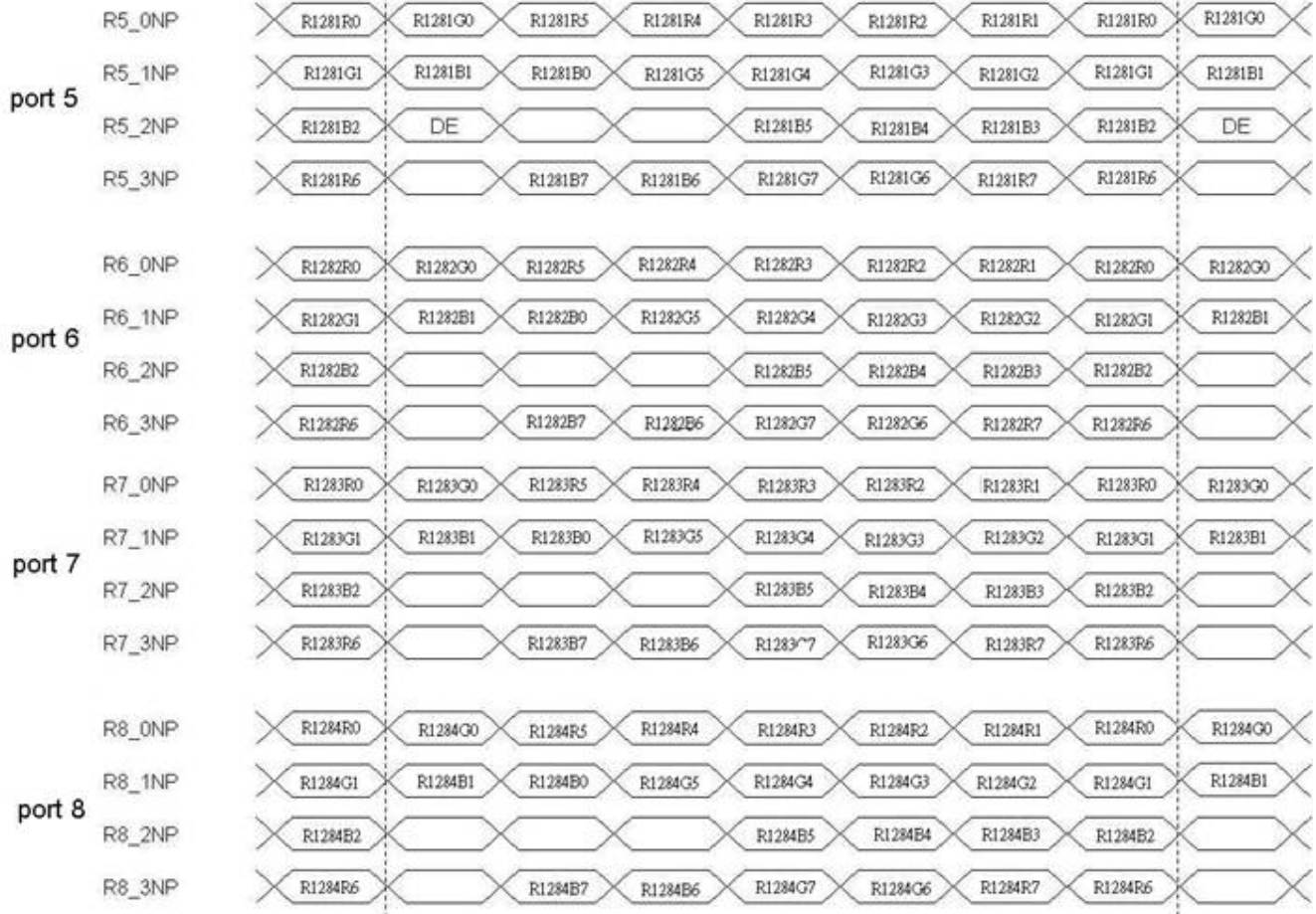

Supply

3.4.3 Color versus Input Data

The following table is for color versus input data (8bit). The higher the gray level, the brighter the color.

Color	Gray Level	Color Input Data																								Remark
		RED data (MSB:R7, LSB:R0)								GREEN data (MSB:G7, LSB:G0)								BLUE data (MSB:B7, LSB:B0)								
		R7	R6	R5	R4	R3	R2	R1	R0	G7	G6	G5	G4	G3	G2	G1	G0	B7	B6	B5	B4	B3	B2	B1	B0	
Black	-	0	0	0	0	0	0	0	0	0	0	0	0	0	0	0	0	0	0	0	0	0	0	0	0	
White	-	1	1	1	1	1	1	1	1	1	1	1	1	1	1	1	1	1	1	1	1	1	1	1	1	
Gray 127	-	0	1	1	1	1	1	1	1	0	1	1	1	1	1	1	1	0	1	1	1	1	1	1	1	
Red	L0	0	0	0	0	0	0	0	0	0	0	0	0	0	0	0	0	0	0	0	0	0	0	0	0	Black
	:	:	:	:	:	:	:	:	:	:	:	:	:	:	:	:	:	:	:	:	:	:	:	:	:	
	L255	1	1	1	1	1	1	1	1	0	0	0	0	0	0	0	0	0	0	0	0	0	0	0	0	
Green	L0	0	0	0	0	0	0	0	0	0	0	0	0	0	0	0	0	0	0	0	0	0	0	0	0	Black
	:	:	:	:	:	:	:	:	:	:	:	:	:	:	:	:	:	:	:	:	:	:	:	:	:	
	L255	0	0	0	0	0	0	0	0	1	1	1	1	1	1	1	1	0	0	0	0	0	0	0	0	
Blue	L0	0	0	0	0	0	0	0	0	0	0	0	0	0	0	0	0	0	0	0	0	0	0	0	0	Black
	:	:	:	:	:	:	:	:	:	:	:	:	:	:	:	:	:	:	:	:	:	:	:	:	:	
	L255	0	0	0	0	0	0	0	0	0	0	0	0	0	0	0	0	1	1	1	1	1	1	1	1	



Supp

3.4.4 LVDS Specification

a. DC Characteristics:

Symbol	Description	Min	Typ	Max	Units	Condition
V_{TH}	LVDS Differential Input High Threshold	-	-	+100	[mV]	$V_{CM} = 1.2V$
V_{TL}	LVDS Differential Input Low Threshold	-100	-	-	[mV]	$V_{CM} = 1.2V$
$ V_{ID} $	LVDS Differential Input Voltage	100	-	600	[mV]	
V_{CM}	LVDS Common Mode Voltage	+1.0	+1.2	+1.5	[V]	$V_{TH}-V_{TL} = 200mV$

LVDS Signal Waveform:

Use RxCLKN & RxCLKP as example.

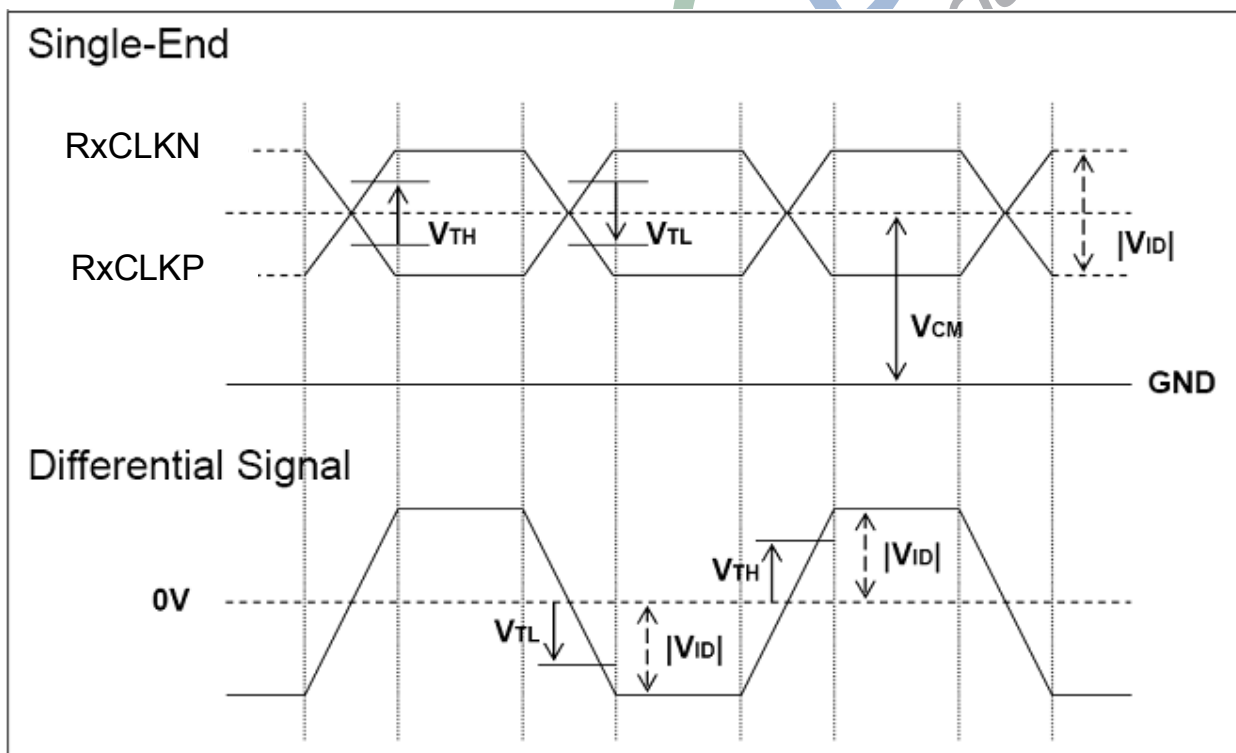

b. AC Characteristics:

Symbol	Description	Min	Max	Unit	Remark
F_{DEV}	Maximum deviation of input clock frequency during Spread Spectrum	-	± 3	%	
F_{MOD}	Maximum modulation frequency of input clock during Spread Spectrum	-	200	KHz	

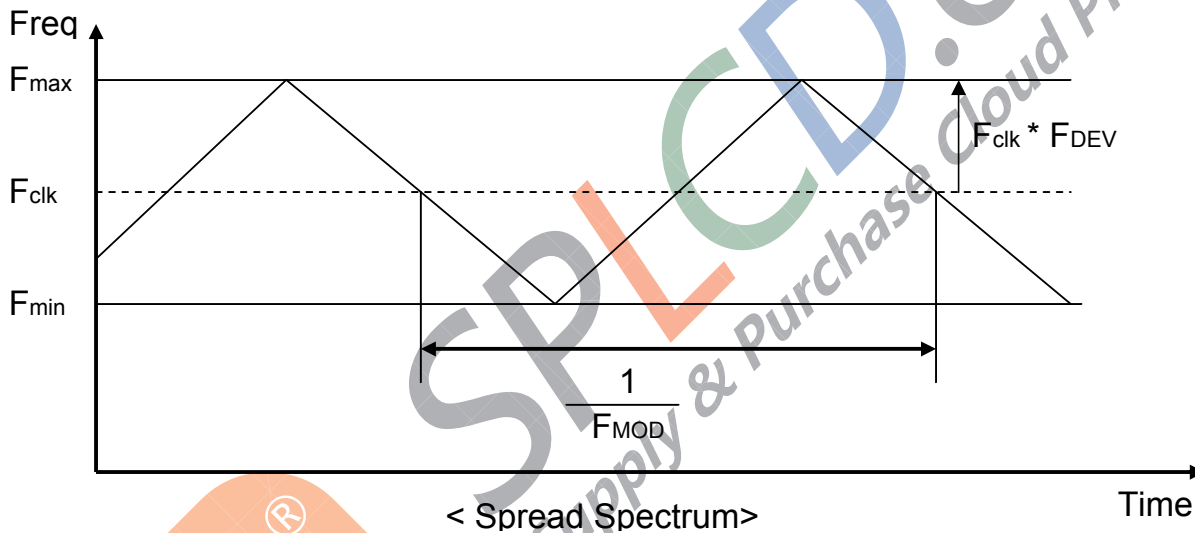

Fclk: LVDS Clock Frequency

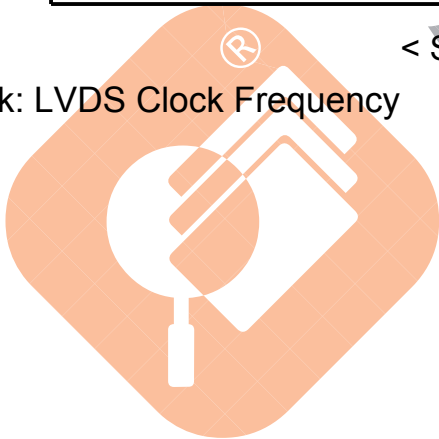

3.4.5 Input Timing Specification

It only support DE mode, and the input timing are shown as the following table.

Symbol	Description		Min.	Typ.	Max.	Unit	Remark
Tv	Vertical Section	Period	1452	1481	8192	Th	
Tdisp (v)		Active	1440	1440	1440	Th	
Tblk (v)		Blanking	12	41	6752	Th	
Fv		Frequency	30	120	145	Hz	Note 3-3
Th	Horizontal Section	Period	359	360	1023	Tclk	
Tdisp (h)		Active	320	320	320	Tclk	
Tblk (h)		Blanking	39	40	703	Tclk	
Fh		Frequency	69.7	177.7	250.6	KHz	Note 3-4
Tclk	LVDS Clock	Period	11.1	15.6	39.9	ns	1/Fclk
Fclk		Frequency	25	64	90	MHz	Note 3-5

Note 3-3: The optimal Vertical Frequency is 119~145 Hz for best picture quality

Note 3-4: The equation is listed as following. Please don't exceed the above recommended value.

$$Fh (\text{Min.}) = Fclk (\text{Min.}) / Th (\text{Min.});$$

$$Fh (\text{Typ.}) = Fclk (\text{Typ.}) / Th (\text{Typ.});$$

$$Fh (\text{Max.}) = Fclk (\text{Max.}) / Th (\text{Min.});$$

Note 3-5: The equation is listed as following. Please don't exceed the above recommended value.

$$Fclk (\text{Typ.}) = Fv (\text{Typ.}) \times Th (\text{Typ.}) \times Tv (\text{Typ.});$$

$$Fclk (\text{Min.}) < Fv \times Th \times Tv < Fclk (\text{Max.})$$

3.4.6 Input Timing Diagram

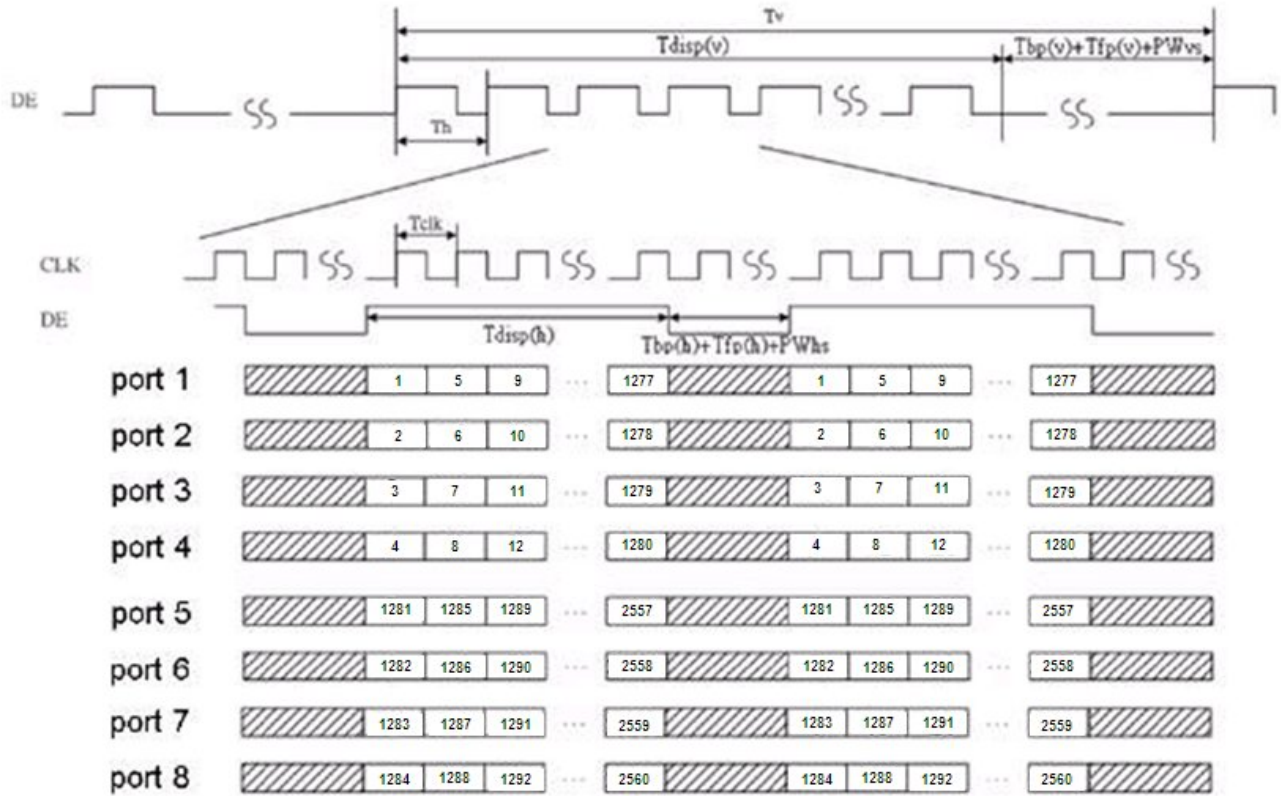

Supply

3.4.7 3D Control

3.4.7.1. 3D control I/O Characteristics

Pin #	Symbol	I/O	Buffer	Description	Remark
CN2_pin 30	Polarity_SYNC	O	4mA	Frame Inversion polarity Index 3D_EN=L :1-frame inversion 3D_EN=H :2-frame inversion	Note 3-6
CN3_pin 30	3D_EN	I	IPL*	3D enable control signal	

* IPL : internal pull low

Note 3-6

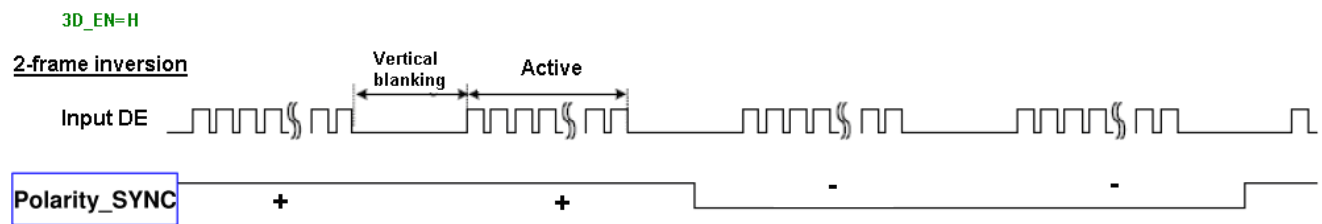
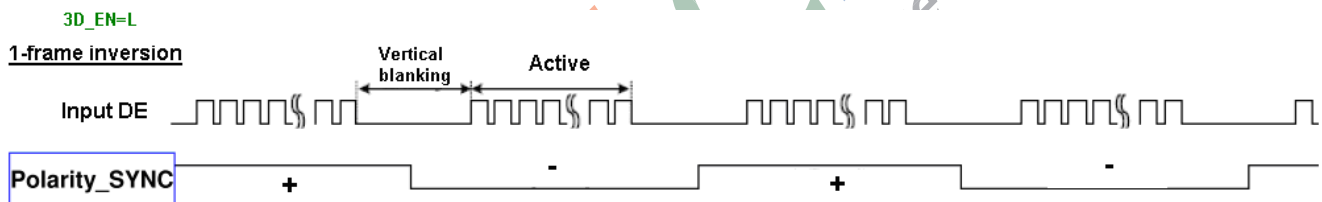

3.4.7.2. Absolute Maximum Rating

Symbol	Description	Min	Max	Unit	Remark
3D_EN	3D enable control signal	GND-0.3	5.0	[Volt]	Ta=25

3.4.7.3. Recommended Operating Condition

Symbol	Parameter	Condition	Rating			Unit
			Min	Typ	Max	
V _{IH}	Input High Voltage	-	2.0	-	3.6	V
V _{IL}	Input Low Voltage	-	0	-	0.8	V
V _{OH}	Output High Voltage	I _{OH} = 4mA	2.4	-	3.4	V
V _{OL}	Output Low Voltage	I _{OL} = -4mA	0	-	0.4	V



SPLCD.COM
 Supply & Purchase Cloud Platform

3.5 Power ON/OFF Sequence

VDD power, LVDS signal and backlight on/off sequence are as following. LVDS signals from any system shall be Hi-Z state when VDD is off.

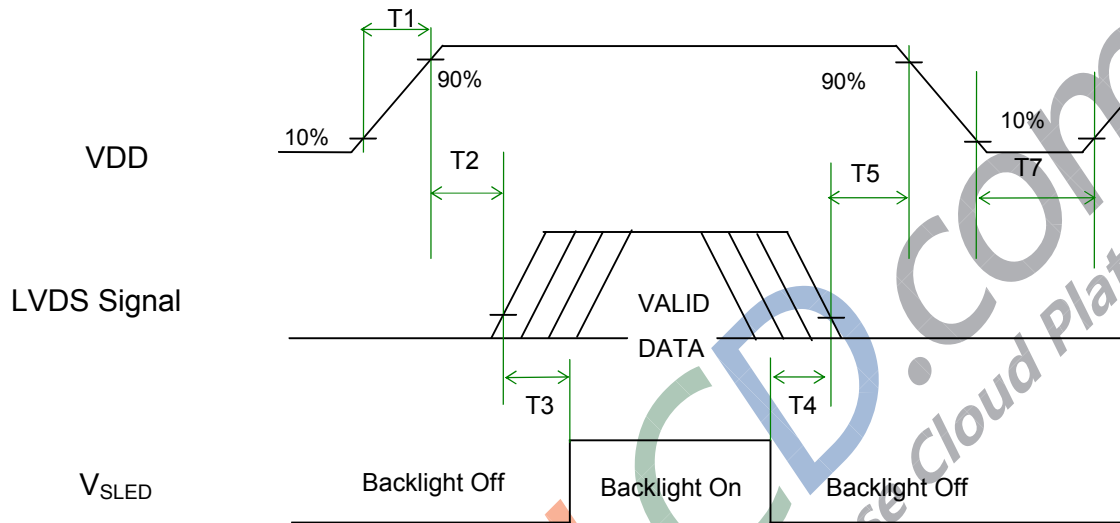

Power Sequence Timing

Symbol	Value			Unit	Remark
	Min.	Typ.	Max.		
T1	0.5	-	10	[ms]	
T2	0	-	50	[ms]	
T3	500	-	-	[ms]	
T4	100	-	-	[ms]	
T5	0	-	50	[ms]	Note 3-7 Note 3-8
T7	1000	-	-	[ms]	

Note 3-7 : Recommend setting T5 = 0ms to avoid electronic noise when VDD is off.

Note 3-8 : During T5 period , please keep the level of input LVDS signals with Hi-Z state.

4 Backlight Unit

4.1 Block Diagram

The following shows the block diagram of the 27 inch Backlight Unit. And it includes 72 pcs LED in the LED light bar. (4 strings and 18 pcs LED of one string).

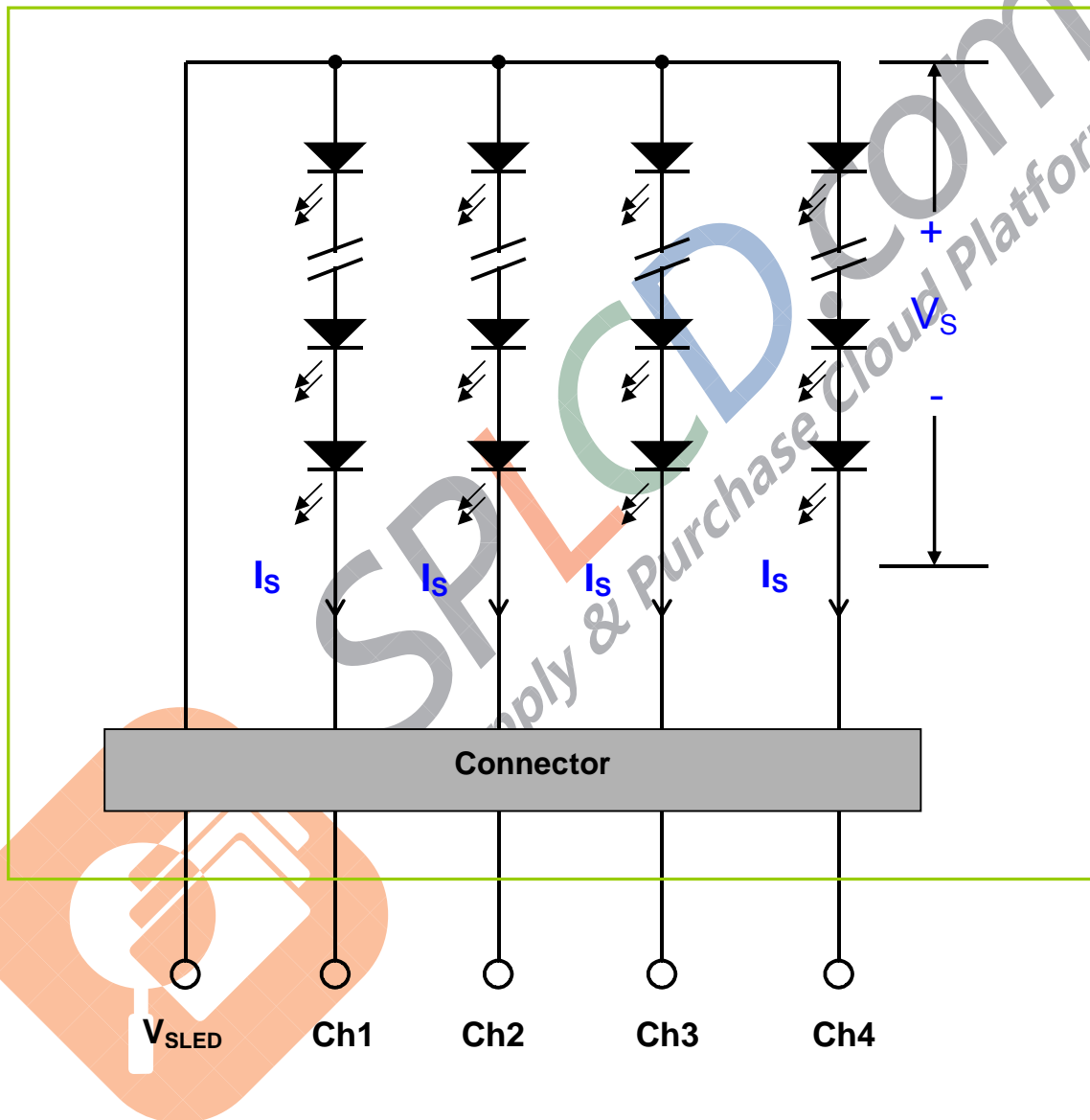

4.2 Interface Connection

4.2.1 Connector Type

Backlight Connector	Manufacturer	ENTERY
	Part Number	3707K-S06N-21R
Mating Connector	Manufacturer	ENTERY or compatible
	Part Number	H112K-P06N-00B (Non-Locking type) H112K-P06N-03B (Locking type)

Backlight Connector dimension:

$H \times V \times D = 13.9 \times 3.00 \times 4.25$, Pitch = 1.0(unit = mm)

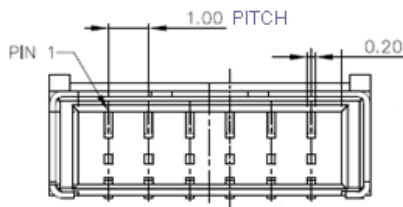
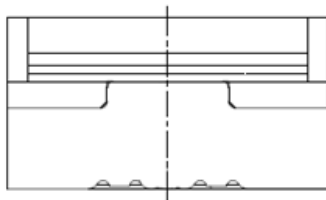

Mating Connector dimension:

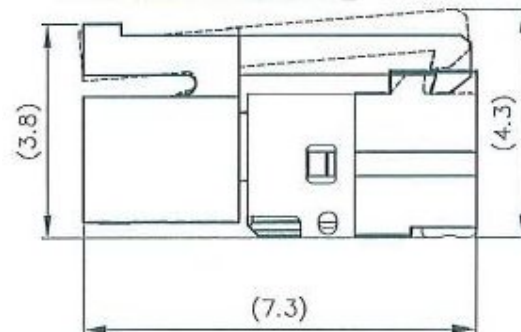
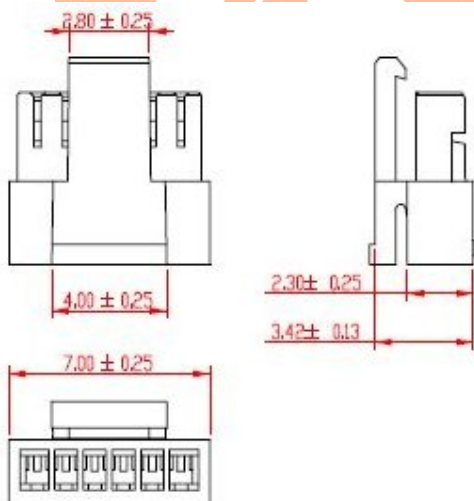

4.2.2 Connector Pin Assignment

Pin#	Symbol	Description	Remark
1	Ch1	LED Current Feedback Terminal (Channel 1)	
2	Ch2	LED Current Feedback Terminal (Channel 2)	
3	V _{SLED}	LED Power Supply Voltage Input Terminal	
4	V _{SLED}	LED Power Supply Voltage Input Terminal	
5	Ch3	LED Current Feedback Terminal (Channel 3)	
6	Ch4	LED Current Feedback Terminal (Channel 4)	



4.3 Electrical Characteristics

4.3.1 Absolute Maximum Rating

Permanent damage may occur if exceeding the following maximum rating.

(Ta=25)

Symbol	Description	Min	Max	Unit	Remark
Is	LED String Current	0	150	[mA]	100% duty ratio
			210	[mA]	Duty ratio 10% Pulse time=10 ms

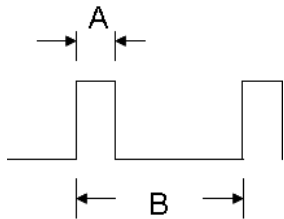

Duty ratio= (A / B) X 100% ; (A: Pulse time, B: Period)

4.3.2 Recommended Operating Condition

(Ta=25)

Symbol	Description	Min.	Typ.	Max.	Unit	Remark
Is	LED String Current	-	120	132	[mA]	100% duty ratio of LED chip
Vs	LED String Voltage	53.1	56.7	60.3	[Volt]	Is=120mA @ 100% duty ratio; Note 4-1, Note 4-5
ΔVs	Maximum Vs Voltage Deviation of light bar	-	-	3.6	[Volt]	Is=120mA @ 100% duty ratio; Note 4-2
P _{BLU}	LED Light Bar Power Consumption	-	27.2	28.9	[Watt]	Note 4-3
LT _{LED}	LED Life Time	30,000	-	-	[Hour]	Note 4-4
OVP	Over Voltage Protection in system board	110% Vs max	-	-	[Volt]	Note 4-5

Note 4-1: V_s (Typ.) = V_F (Typ.) X LED No. (one string);

a. V_F : LED chip forward voltage, V_F (Min.)=2.95V, V_F (Typ.)=3.15V, V_F (Max.)=3.35V

b. The same equation to calculate V_s (Min.) & V_s (Max.) for respective V_F (Min.) & V_F (Max.);

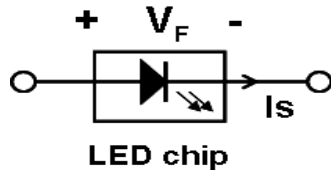

Note 4-2: ΔV_s (Max.) = ΔV_F X LED No. (one string);

a. ΔV_F : LED chip forward voltage deviation; (0.2 V , each Bin of LED V_F)

Note 4-3: P_{BLU} (Typ.) = V_s (Typ.) X I_s (Typ.) X 4 ; (4 is total String No. of LED Light bar)

P_{BLU} (Max.) = V_s (Max.) X I_s (Typ.) X 4 ;

Note 4-4: Definition of life time:

a. Brightness of LED becomes to 50% of its original value

b. Test condition: I_s = 120mA and 25 (Room Temperature)

Note 4-5: Recommendation for LED driver power design:

Due to there are electrical property deviation in LED & monitor set system component after long time operation. AUO strongly recommend the design value of LED driver board OVP (over voltage protection) should be 10% higher than max. value of LED string voltage (V_s) at least.

Note 4-6: AUO strongly recommend "Analog Dimming" method for backlight brightness control for Wavy Noise Free. Otherwise, recommend that Dimming Control Signal (PWM Signal) should be synchronized with Frame Frequency.

5 Reliability Test

AUO reliability test items are listed as following table. (*Bare Panel only*)

Items	Condition	Remark
Temperature Humidity Bias (THB)	Ta= 50 , 80%RH, 300hours	
High Temperature Operation (HTO)	Ta= 50 , 50%RH, 300hours	
Low Temperature Operation (LTO)	Ta= 0 , 300hours	
High Temperature Storage (HTS)	Ta= 60 , 300hours	
Low Temperature Storage (LTS)	Ta= -20 , 300hours	
Vibration Test (Non-operation)	Acceleration: 1.5 Grms Wave: Random Frequency: 10 - 200 Hz Sweep: 30 Minutes each Axis (X, Y, Z)	
Shock Test (Non-operation)	Acceleration: 50 G Wave: Half-sine Active Time: 20 ms Direction: ±X, ±Y, ±Z (one time for each Axis)	
Thermal Shock Test (TST)	-20 /30min, 60 /30min, 100 cycles	Note 5-1
On/Off Test	On/10sec, Off/10sec, 30,000 cycles	
ESD (Electro Static Discharge)	Contact Discharge: ± 15KV, 150pF(330Ω) 1sec, 8 points, 25 times/ point.	Note 5-2
	Air Discharge: ± 15KV, 150pF(330Ω) 1sec 8 points, 25 times/ point.	
Altitude Test	Operation:18,000 ft Non-Operation:40,000 ft	

Note 5-1: a. A cycle of rapid temperature change consists of varying the temperature from -20 to 60 , and back again. Power is not applied during the test.
b. After finish temperature cycling, the unit is placed in normal room ambient for at least 4 hours before power on.

Note 5-2: EN61000-4-2, ESD class B: Certain performance degradation allowed
No data lost
Self-recoverable
No hardware failures.

6 Shipping Label

The label is on the panel as shown below:



Note 6-1: For Pb Free products, AUO will add  for identification.

Note 6-2: For RoHS compatible products, AUO will add  for identification.

Note 6-3: For China RoHS compatible products, AUO will add  for identification.

Note 6-4: The Green Mark will be presented only when the green documents have been ready by AUO Internal Green Team.



7 Mechanical Characteristics

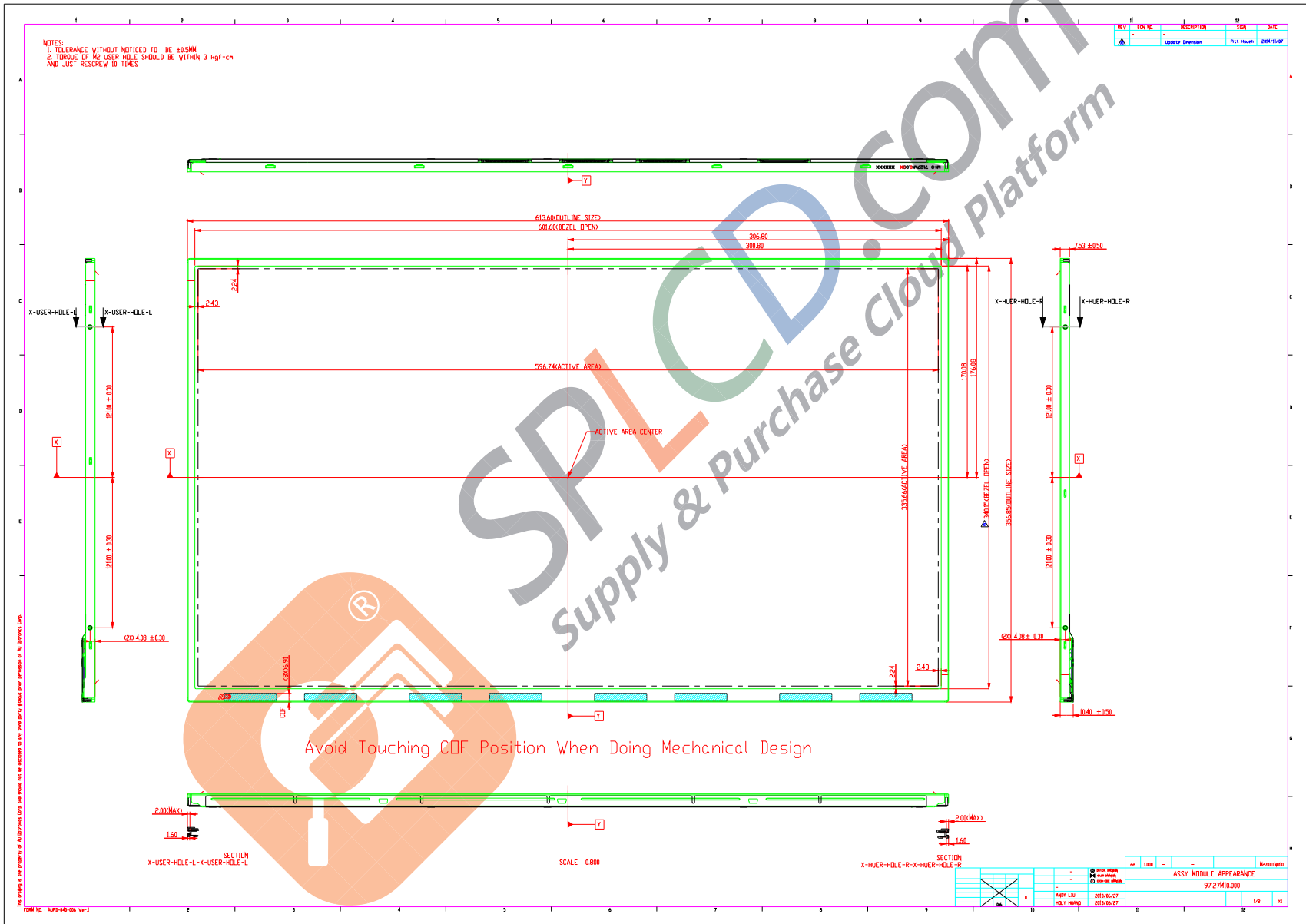

Ver 1.0

8 Packing Specification

8.1 Packing Flow

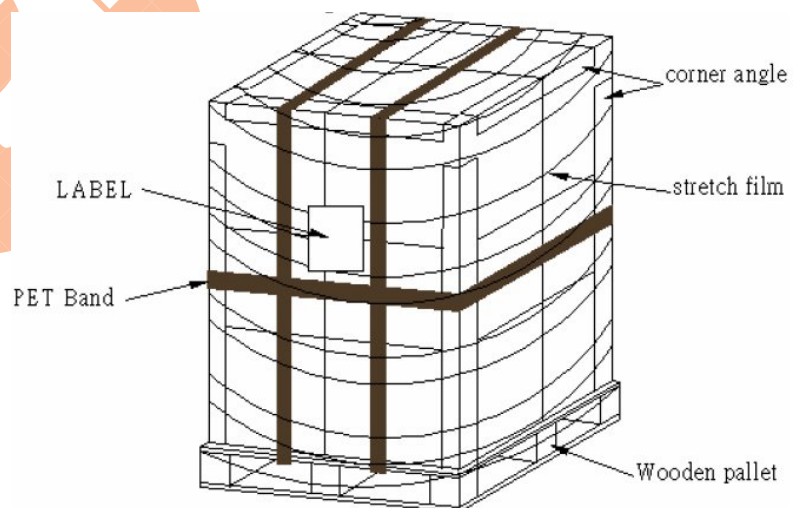
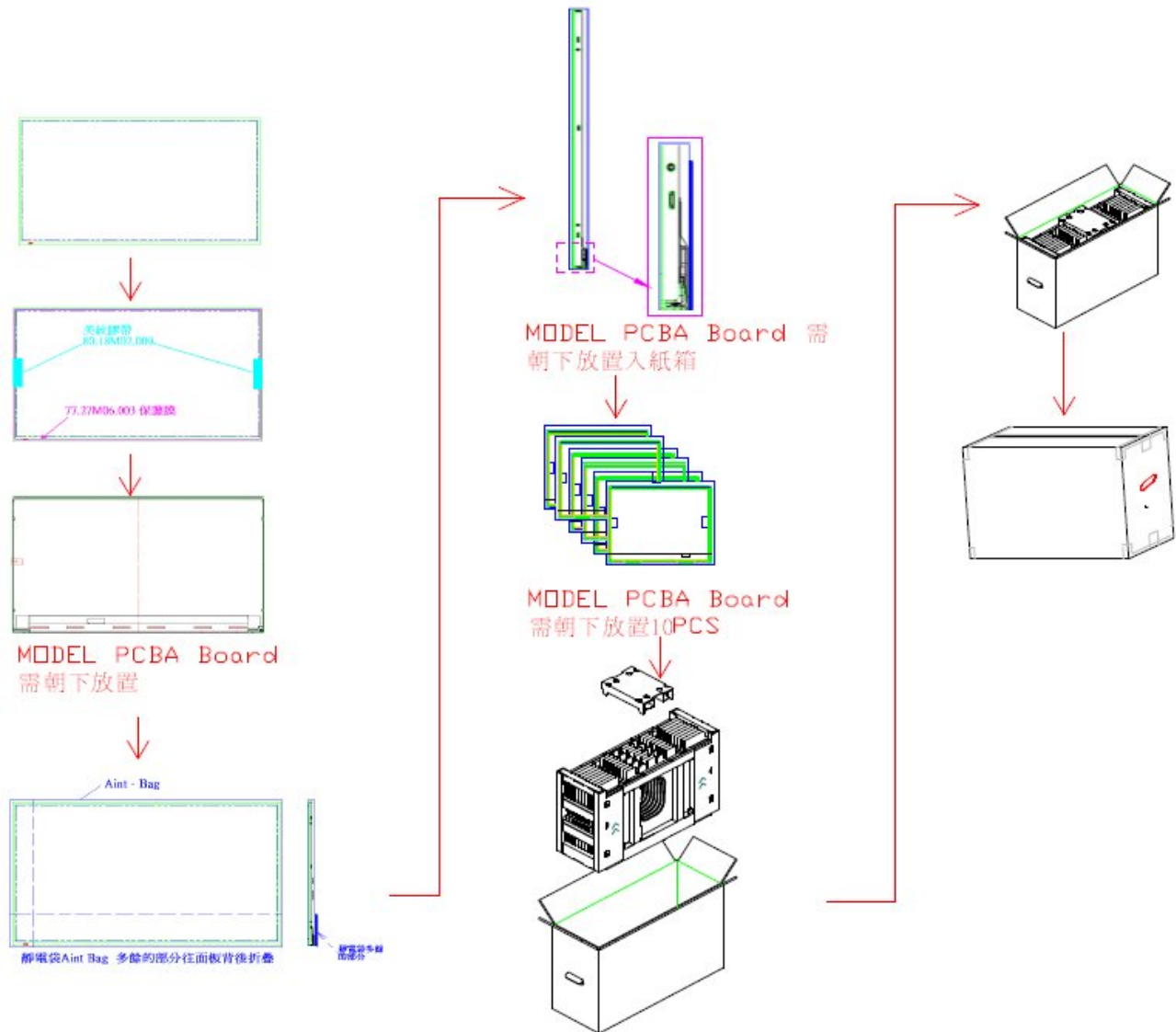

Ver 1.0

8.2 Pallet and shipment information

Item	Specification			Remark
	Q'ty	Dimension	Weight (kg)	
Panel	1	613.6(H)mm × 356.85(V)mm × 10.4(D)mm	2.2	
Cushion	1	-	3.954	
Box	1	708(L)mm x 261(W)mm x 473(H)mm	1.378	without Panel & cushion
Packing Box	10 pcs/Box	556(L)mm x 292(W)mm x 375(H)mm	27.33	with panel & cushion
Pallet	1	1070(L)mm x 740(W)mm x 132(H)mm	14.80	
Pallet after Packing	8 boxes/pallet	1070(L)mm x 740(W)mm x 1086(H)mm	233.44	



SPLCD.COM
Supply & Purchase Cloud Platform