

( ) Preliminary Specification

( V ) Final Specification

<b>Module</b>	27" Color TFT-LCD
<b>Model Name</b>	M270DTN01.5
<b>Suffix Name</b>	
<b>Document version</b>	D01

Document		
<b>APPROVED BY</b>	James Kuo	Date: 2015/10/19
<b>PREPARED BY</b>	Junda Lin	Date : 2015/10/19

CUSTOMER APPROVED AND FEEDBACK		
<b>CUSTOMER</b>		
<b>APPROVED BY</b>		Date :

Note: This Specification is subject to change without notice.

## Contents

Item	Page
1. Handling Precautions	4
2. General Description	5
3. Functional Block Diagram	10
4. Absolute Maximum Ratings	16
5. Electrical characteristics	17
6. Signal Characteristic	18
7. Connector & Pin Assignment	28
8. Reliability Test	35
9. Shipping Label	36
10. Packing Precautions	37
11. Drawing	38

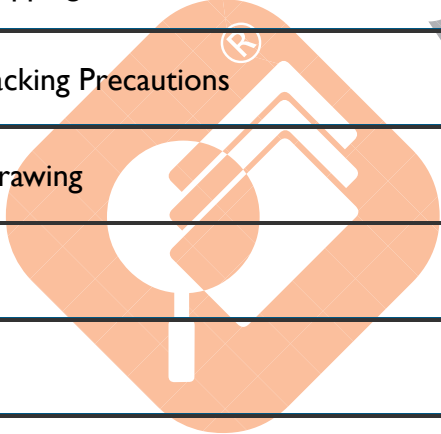

SPLCD.com  
 Supply & Purchase Cloud Platform



## 1. Handling Precautions

1. Since front polarizer is easily damaged, pay attention not to scratch it.
2. Be sure to turn off power supply when inserting or disconnecting from input connector.
3. Wipe off water drop immediately. Long contact with water may cause discoloration or spots.
4. When the panel surface is soiled, wipe it with absorbent cotton or other soft cloth.
5. Since the panel is made of glass, it may break or crack if dropped or bumped on hard surface.
6. Since CMOS LSI is used in this module, take care of static electricity and insure human earth when handling.
7. Do not open or modify the Module Assembly.
8. Do not press the reflector sheet at the back of the module to any directions.
9. In case if a Module has to be put back into the packing container slot after once it was taken out from the container, do not press the center of the LED lightbar edge. Instead, press at the far ends of the LED light bar edge softly. Otherwise the TFT Module may be damaged.
10. At the insertion or removal of the Signal Interface Connector, be sure not to rotate nor tilt the Interface Connector of the TFT Module.
11. After installation of the TFT Module into an enclosure, do not twist nor bend the TFT Module even momentary. At designing the enclosure, it should be taken into consideration that no bending/twisting forces are applied to the TFT Module from outside. Otherwise the TFT Module may be damaged.
12. Small amount of materials having no flammability grade is used in the LCD module. The LCD module should be supplied by power complied with requirements of Limited Power Source (IEC60950 or UL1950), or be applied exemption.
13. Please avoid touching COF Position while you are doing mechanical design.
14. When storing modules as spares for a long time, the following precaution is necessary:
  - a. Store them in a dark place. Do not expose the module to sunlight or fluorescent light.
  - b. Keep the temperature between 5°C and 35°C at normal humidity.

## 2. General Description

This specification applies to the 27 inch-FHD Color a-Si TFT-LCD Module M270DTN01.5. The display supports the QHD - 2560(H) x 1440(V) screen format and 16.7M colors (RGB 8-bits data). The input interface is 8 port LVDS and this module doesn't contain a driver board for backlight.

### Display Characteristics

The following items are characteristics summary on the table under 25°C condition:

ITEMS	Unit	SPECIFICATIONS
Screen Diagonal	mm	684.67(27.0")
Active Area	mm	596.74 (H) x 335.66 (V)
Pixels H x V		2560(x3) x 1440
Pixel Pitch	um	233.1 (per one triad) x233.1
Pixel Arrangement		R.G.B. Vertical Stripe
Display Mode		TN Mode, Normally White
White Luminance ( Center )	cd/m <sup>2</sup>	350 cd/m <sup>2</sup> (Typ.)
Contrast Ratio		1000(Typ.)
Optical Response Time	msec	5ms (Typ., on/off)
Power Consumption (VDD line + LED line)	Watt	33.8 W LCD module:PDD(Typ)=6.5 @Black pattern Fv=144 Hz Backlight unit:PBLu(Typ)=27.3 @Is=120mA
Color gamut	%	72
Weight	Grams	2500 (Typ.)
Outline Dimension	mm	609.00(H)x354.66(V)x11.60(D)
Electrical Interface		8 port LVDS
Support Color		16.7M colors (RGB 8-bit )
Surface Treatment		Anti-Glare, 3H
Temperature Range	°C	0 to +50
Operating	°C	-20 to +60
Storage (Shipping)		
RoHS Compliance		RoHS Compliance
TCO Compliance		TCO 6.0 Compliance

## Optical Characteristics

The optical characteristics are measured on the following test condition.

### Test Condition :

1.Equipment setuo:Please refer to Note 2-1

2.Panel Lighting:30 Minutes

3.VDD=12.0V, Fv=144Hz, Is=120mA, Ta=2.5°C

Symbol	Description	Min.	Typ.	Max.	Unit	Remark			
L <sub>w</sub>	White Luminance (Center of screen)	300	350	-	[cd/m <sup>2</sup> ]	Note 2-1			
L <sub>uni</sub>	Luminance Uniformity (9 points)	75	80	-	[%]	Note 2-1			
CR	Contrast Ratio (Center of screen)	600	1000	-	-	Note 2-1			
θ <sub>R</sub>	Horizontal Viewing Angle (CR=10)	Right	75	85	-	[degree]	Note 2-2 By SR-3		
θ <sub>L</sub>		Left	75	85	-				
Φ <sub>R</sub>	Vertical Viewing Angle (CR=10)	Up	70	80	-				
Φ <sub>L</sub>		Down	70	80	-				
θ <sub>R</sub>	Horizontal Viewing Angle (CR=5)	Right	75	88	-				
θ <sub>L</sub>		Left	75	88	-				
Φ <sub>R</sub>	Vertical Viewing Angle (CR=5)	Up	70	85	-				
Φ <sub>L</sub>		Down	70	85	-				
T <sub>R</sub>	Response Time	Rising Time	-	3.5	5.5			[msec]	Note 2-4 By TRD-1000
T <sub>L</sub>		Falling Time	-	1.5	2.5				
		Rising + Falling	-	5	8				
R <sub>x</sub>	Color Coordinates (CIE 1931)	Red x	0.616	0.646	0.676				By SR-3
R <sub>y</sub>		Red y	0.314	0.344	0.374				
G <sub>x</sub>		Green x	0.285	0.315	0.345				
G <sub>y</sub>		Green y	0.595	0.625	0.655				
B <sub>x</sub>		Blue x	0.110	0.140	0.170				
B <sub>y</sub>		Blue y	0.015	0.045	0.075				
W <sub>x</sub>		White x	0.283	0.313	0.343				
W <sub>y</sub>		White y	0.299	0.329	0.359				
CT	Crosstalk	-	-	1.5	[%]	Note 2-8			
F <sub>dB</sub>	Flicker (Center of screen)	-	-	-20	[dB]	Note 2-9			

**Note 2-1: Measurement method**

The LCD module should be stabilized at given temperature for 30 minutes to avoid abrupt temperature change during measuring (at surface 35°C). In order to stabilize the luminance, the measurement should be executed after lighting Backlight for 30 minutes in a stable, windless and dark room.

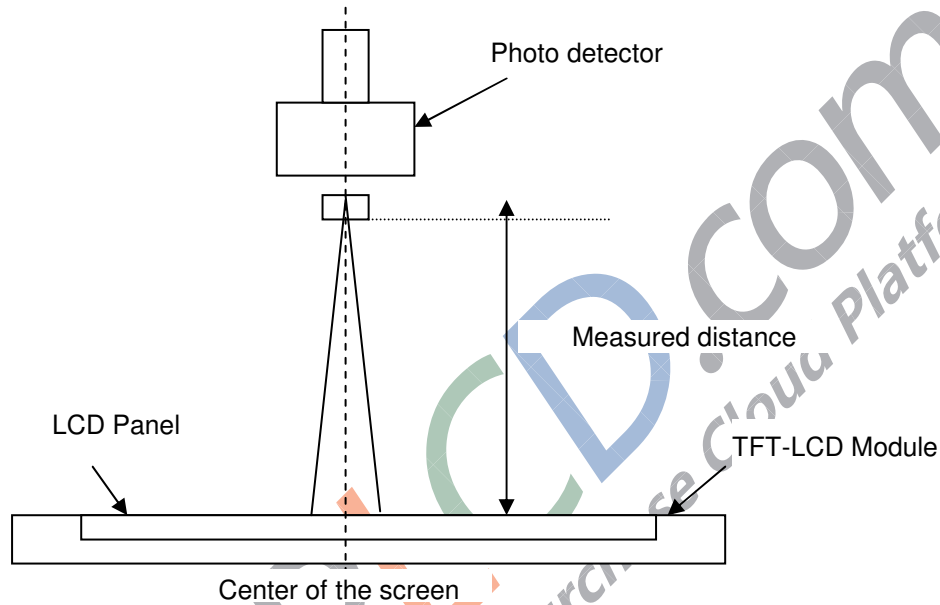

**Note 2-2: Definition of viewing angle measured by ELDIM (EZContrast 88)**

Viewing angle is the measurement of contrast ratio  $\geq 10$ , at the screen center, over a 180° horizontal and 180° vertical range (off-normal viewing angles). The 180° viewing angle range is broken down as follows; 90° ( $\theta$ ) horizontal left and right and 90° ( $\Phi$ ) vertical, high (up) and low (down). The measurement direction is typically perpendicular to the display surface with the screen rotated about its center to develop the desired measurement viewing angle.

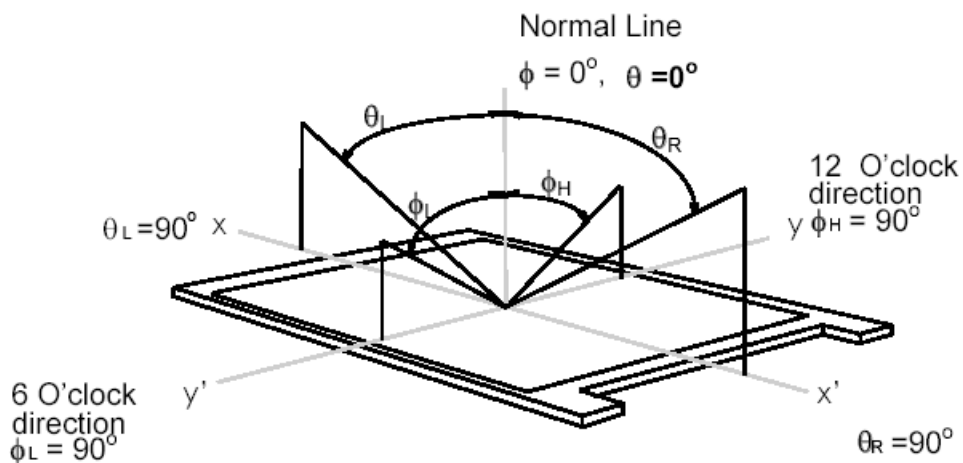

Note 2-3: Contrast ratio is measured by TOPCON SR-3

Note 2-4: Definition of Response time measured by Westar TRD-100A

The output signals of photo detector are measured when the input signals are changed from “Black” to “White” (rising time,  $T_R$ ), and from “White” to “Black” (falling time,  $T_F$ ), respectively. The response time is interval between the 10% and 90% of optical response. (Black & White color definition: Please refer section 3.4.3)

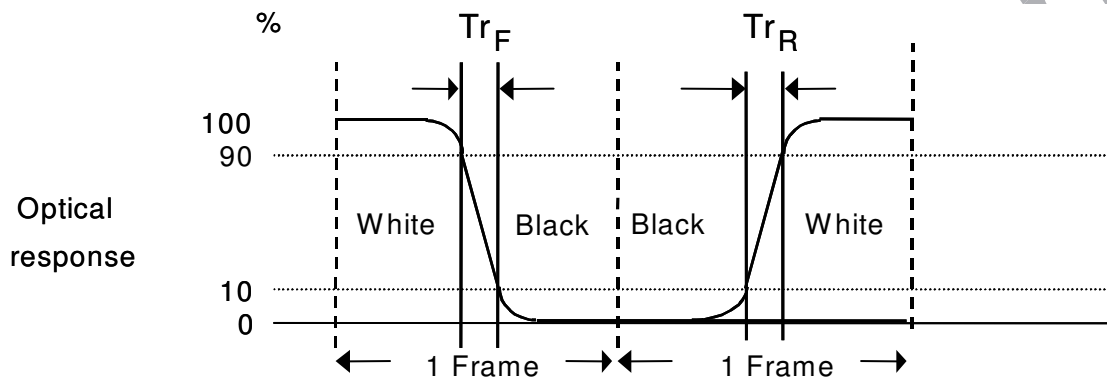

Note 2-5: Color chromaticity and coordinates (CIE) is measured by TOPCON SR-3

Note 2-6: Central luminance is measured by TOPCON SR-3

Note 2-7: Luminance uniformity of these 9 points is defined as below and measured by TOPCON SR-3

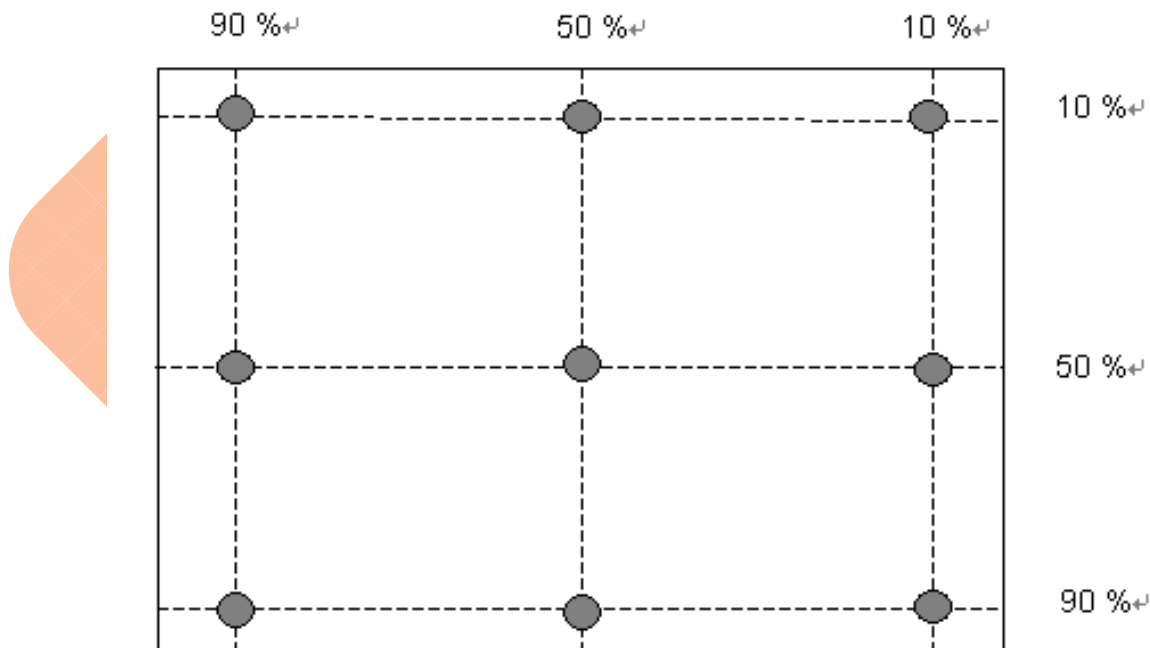

$$\text{Uniformity} = \frac{\text{Minimum Luminance in 9 points (1-9)}}{\text{Maximum Luminance in 9 Points (1-9)}}$$



**Note 2-8: Crosstalk is defined as below and measured by TOPCON SR-3**

Crosstalk measurement

**Definition:**

$$CT = \text{Max. } (CT_H, CT_V);$$

Where

a. Maximum Horizontal Crosstalk :

$$CT_H = \text{Max. } (|Y_{BL} - Y_{AL}| / Y_{AL} \times 100 \%, |Y_{BR} - Y_{AR}| / Y_{AR} \times 100 \%);$$

Maximum Vertical Crosstalk:

$$CT_V = \text{Max. } (|Y_{BU} - Y_{AU}| / Y_{AU} \times 100 \%, |Y_{BD} - Y_{AD}| / Y_{AD} \times 100 \%);$$

b.  $Y_{AU}, Y_{AD}, Y_{AL}, Y_{AR}$  = Luminance of measured location without Black pattern

$Y_{BU}, Y_{BD}, Y_{BL}, Y_{BR}$  = Luminance of measured location with Black pattern

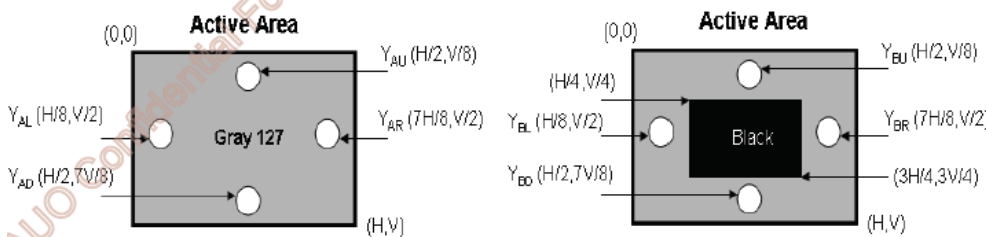

**Note 2-9: Test Pattern: Subchecker Pattern measured by TOPCON SR-3**

Flicker measurement

a. Test pattern: It is listed as following.

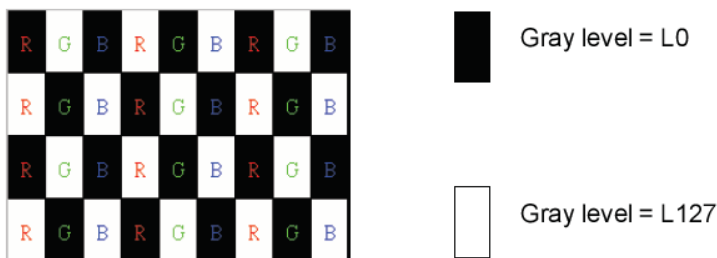

R: Red, G: Green, B:Blue

b. Measured position: Center of screen & perpendicular to the screen

### 3. Functional Block Diagram

#### 3. TFT-LCD

##### 3-1. Block Diagram

The following shows the block diagram of the 27 inch Color TFT-LCD Module

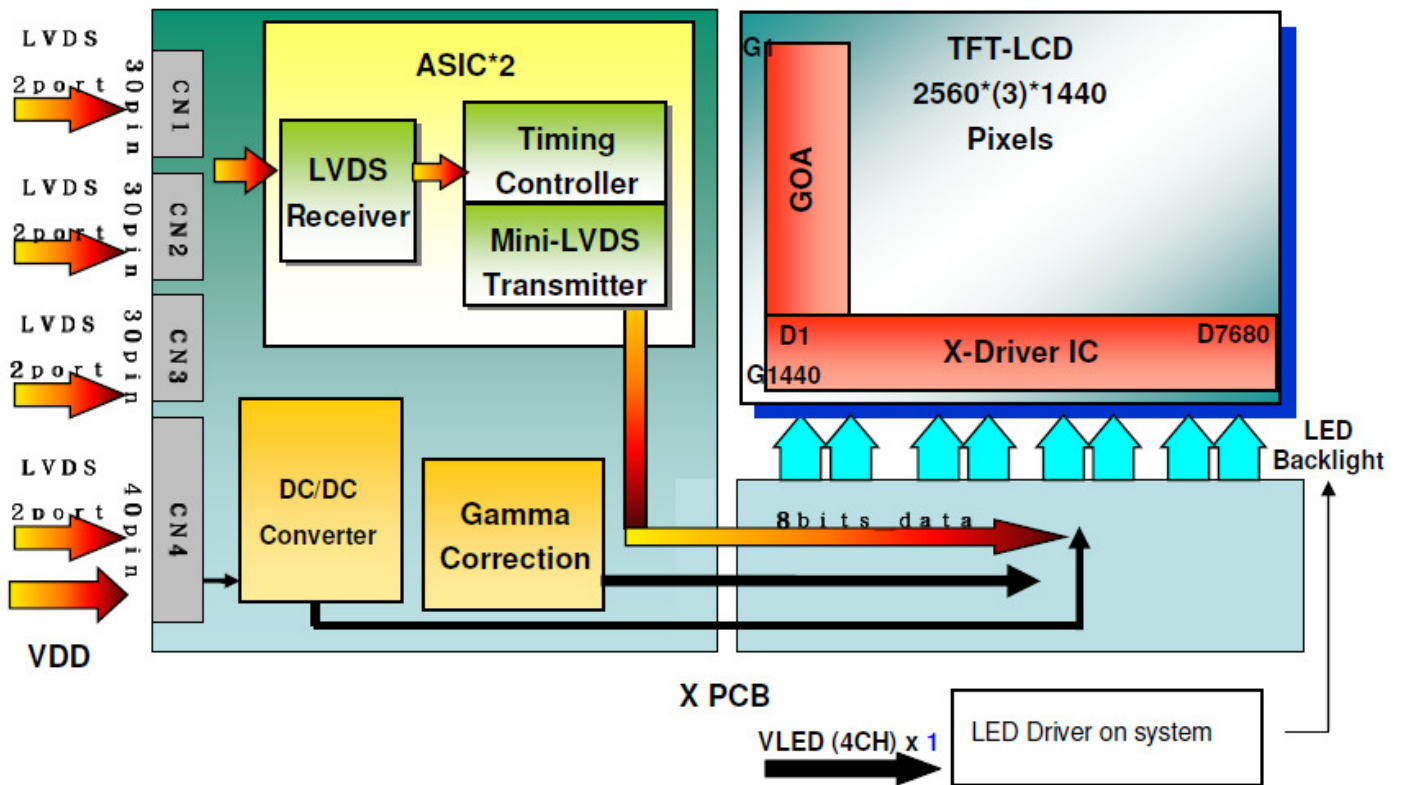

## 3.2. Signal Description

CN1

PIN #	Symbol	DESCRIPTION
1	R1 0N	Negative LVDS differential data input (Port1 data)
2	R1 0P	Positive LVDS differential data input (Port1 data)
3	R1 1N	Negative LVDS differential data input (Port1 data)
4	R1 1P	Positive LVDS differential data input (Port1 data)
5	R1 2N	Negative LVDS differential data input (Port1 data)
6	R1 2P	Positive LVDS differential data input (Port1 data)
7	GND	Ground
8	R1 CLKN	Negative LVDS differential clock input (Port1 clock)
9	R1 CLKP	Positive LVDS differential clock input (Port1 clock)
10	GND	Ground
11	R2 3N	Negative LVDS differential data input (Port1 data)
12	R2 3P	Positive LVDS differential data input (Port1 data)
13	NC	No connection (for AUO test only. Do not connect)
14	NC	No connection (for AUO test only. Do not connect)
15	GND	Ground
16	R2 0N	Negative LVDS differential data input (Port2 data)
17	R2 0P	Positive LVDS differential data input (Port2 data)
18	R2 1N	Negative LVDS differential data input (Port2 data)
19	R2 1P	Positive LVDS differential data input (Port2 data)
20	R2 2N	Negative LVDS differential data input (Port2 data)
21	R2 2P	Positive LVDS differential data input (Port2 data)
22	GND	Ground
23	R2 CLKN	Negative LVDS differential clock input (Port2 clock)
24	R2 CLKP	Positive LVDS differential clock input (Port2 clock)
25	GND	Ground
26	R2 3N	Negative LVDS differential data input (Port2 data)
27	R2 3P	Positive LVDS differential data input (Port2 data)
28	NC	No connection (for AUO test only. Do not connect)
29	NC	No connection (for AUO test only. Do not connect)
30	NC	No connection (for AUO test only. Do not connect)

CN2

PIN #	Symbol	DESCRIPTION
1	R3_0N	Negative LVDS differential data input (Port3 data)
2	R3_0P	Positive LVDS differential data input (Port3 data)
3	R3_1N	Negative LVDS differential data input (Port3 data)
4	R3_1P	Positive LVDS differential data input (Port3 data)
5	R3_2N	Negative LVDS differential data input (Port3 data)
6	R3_2P	Positive LVDS differential data input (Port3 data)
7	GND	Ground
8	R3_CLKN	Negative LVDS differential clock input (Port3 clock)
9	R3_CLKP	Positive LVDS differential clock input (Port3 clock)
10	GND	Ground
11	R3_3N	Negative LVDS differential data input (Port3 data)
12	R3_3P	Positive LVDS differential data input (Port3 data)
13	NC	No connection (for AUO test only. Do not connect)
14	NC	No connection (for AUO test only. Do not connect)
15	GND	Ground
16	R4_0N	Negative LVDS differential data input (Port4 data)
17	R4_0P	Positive LVDS differential data input (Port4 data)
18	R4_1N	Negative LVDS differential data input (Port4 data)
19	R4_1P	Positive LVDS differential data input (Port4 data)
20	R4_2N	Negative LVDS differential data input (Port4 data)
21	R4_2P	Positive LVDS differential data input (Port4 data)
22	GND	Ground
23	R4_CLKP	Negative LVDS differential clock input (Port4 clock)
24	R4_CLKP	Positive LVDS differential clock input (Port4 clock)
25	GND	Ground
26	R4_3N	Negative LVDS differential data input (Port4 data)
27	R4_3P	Positive LVDS differential data input (Port4 data)
28	NC	No connection (for AUO test only. Do not connect)
29	NC	No connection (for AUO test only. Do not connect)
30	Polarity_SYNC	Polarity SYNC (O)

CN3

PIN #	Symbol	DESCRIPTION
1	R5_0N	Negative LVDS differential data input (Port5 data)
2	R5_0P	Positive LVDS differential data input (Port5 data)
3	R5_1N	Negative LVDS differential data input (Port5 data)
4	R5_1P	Positive LVDS differential data input (Port5 data)
5	R5_2N	Negative LVDS differential data input (Port5 data)
6	R5_2P	Positive LVDS differential data input (Port5 data)
7	GND	Ground
8	R5_CLKN	Negative LVDS differential clock input (Port5 clock)
9	R5_CLKP	Positive LVDS differential clock input (Port5 clock)
10	GND	Ground
11	R5_3N	Negative LVDS differential data input (Port5 data)
12	R5_3P	Positive LVDS differential data input (Port5 data)
13	NC	No connection (for AUO test only. Do not connect)
14	NC	No connection (for AUO test only. Do not connect)
15	GND	Ground
16	R6_0N	Negative LVDS differential data input (Port6 data)
17	R6_0P	Positive LVDS differential data input (Port6 data)
18	R6_1N	Negative LVDS differential data input (Port6 data)
19	R6_1P	Positive LVDS differential data input (Port6 data)
20	R6_2N	Negative LVDS differential data input (Port6 data)
21	R6_2P	Positive LVDS differential data input (Port6 data)
22	GND	Ground
23	R6_CLKP	Negative LVDS differential clock input (Port6 clock)
24	R6_CLKP	Positive LVDS differential clock input (Port6 clock)
25	GND	Ground
26	R6_3N	Negative LVDS differential data input (Port6 data)
27	R6_3P	Positive LVDS differential data input (Port6 data)
28	NC	No connection (for AUO test only. Do not connect)
29	NC	No connection (for AUO test only. Do not connect)
30	3D_EN (I)	3D_EN (I)

CN4

PIN #	Symbol	DESCRIPTION
1	R7 0N	Negative LVDS differential data input (Port7 data)
2	R7 0P	Positive LVDS differential data input (Port7 data)
3	R7 1N	Negative LVDS differential data input (Port7 data)
4	R7 1P	Positive LVDS differential data input (Port7 data)
5	R7 2N	Negative LVDS differential data input (Port7 data)
6	R7 2P	Positive LVDS differential data input (Port7 data)
7	GND	Ground
8	R7 CLKN	Negative LVDS differential clock input (Port7 clock)
9	R7 CLKP	Positive LVDS differential clock input (Port7 clock)
10	GND	Ground
11	R7 3N	Negative LVDS differential data input (Port7 data)
12	R7 3P	Positive LVDS differential data input (Port7 data)
13	NC	No connection (for AUO test only. Do not connect)
14	NC	No connection (for AUO test only. Do not connect)
15	GND	Ground
16	R8 0N	Negative LVDS differential data input (Port8 data)
17	R8 0P	Positive LVDS differential data input (Port8 data)
18	R8 1N	Negative LVDS differential data input (Port8 data)
19	R8 1P	Positive LVDS differential data input (Port8 data)
20	R8 2N	Negative LVDS differential data input (Port8 data)
21	R8 2P	Positive LVDS differential data input (Port8 data)
22	GND	Ground
23	R8 CLKN	Negative LVDS differential clock input (Port8 clock)
24	R8 CLKP	Positive LVDS differential clock input (Port8 clock)
25	GND	Ground
26	R8 3N	Negative LVDS differential data input (Port8 data)
27	R8 3P	Positive LVDS differential data input (Port8 data)
28	NC	No connection (for AUO test only. Do not connect)
29	NC	No connection (for AUO test only. Do not connect)
30	NC	No connection (for AUO test only. Do not connect)
31	NC	No connection (for AUO test only. Do not connect)
32	NC	No connection (for AUO test only. Do not connect)
33	NC	No connection (for AUO test only. Do not connect)
34	GND	Ground
35	GND	Ground
36	NC	No connection (for AUO test only. Do not connect)

37	VDD	Power Supply Input Voltage
38	VDD	Power Supply Input Voltage
39	VDD	Power Supply Input Voltage
40	VDD	Power Supply Input Voltage

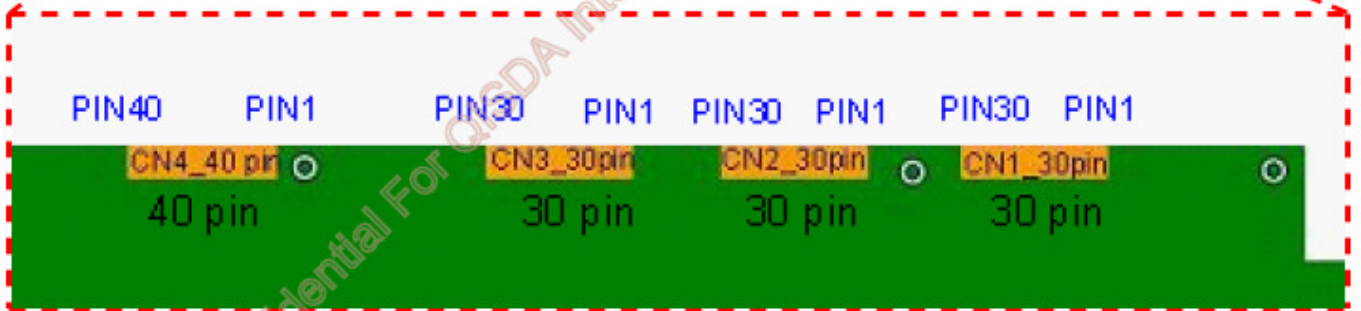

## 4. Absolute Maximum Ratings

Absolute maximum ratings of the module are as following:

### Backlight Unit

	Symbol	Min	Typ	Max	Unit	Conditions
LED Current	ILED	-	120	132	[mA]	Note 4-1,4-2

### Absolute Ratings of Environment

Item	Symbol	Min.	Max.	Unit	Conditions
Operating Temperature	TOP	0	+50	[°C]	<b>Note 4-3</b>
Center Glass Surface temperature (Operation)	TGS	0	+65	[°C]	<b>Note 4-3</b> <b>Function judged only</b>
Operation Humidity	HOP	5	90	[%RH]	<b>Note 4-3</b>
Storage Temperature	TST	-20	+60	[°C]	
Storage Humidity	HST	5	90	[%RH]	

Note 4-1: With in Ta (25 °C)

Note 4-2: Permanent damage to the device may occur if exceeding maximum values

Note 4-3: For quality performance, please refer to AUO IIS(Incoming Inspection Standard).

- 90% RH Max ( Ta ≤ 39°C)
- Max wet-bulb temperature at 39°C or less ( Ta ≤ 39°C)
- No condensation

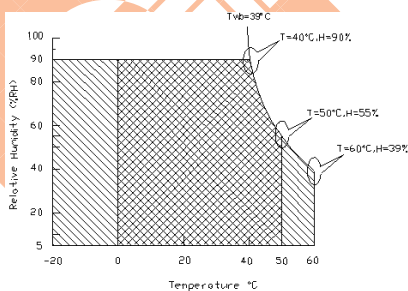

Operating Range



Storage Range

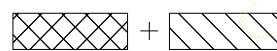



## 5. Electrical characteristics-TFT LCD Module

### Power Specification

Input power specifications are as following:

Permanent damage may occur if exceeding the following maximum rating.

Symbol	Description	Min	Max	Unit	Remark
VDD	Power Supply Input Voltage	GND-0.3	14	[Volt]	Ta=25°C

### Recommended Operating Condition

Symbol	Description	Min	Typ	Max	Unit	Remark
VDD	Power Supply Input Voltage	10.8	12	13.2	[Volt]	
IDD	Power Supply Input Current (RMS)	-	0.5	1.3	[A]	VDD= 12.0V, All Black Pattern At 144Hz,
PDD	VDD Power Consumption	-	6.5	15.6	[Watt]	VDD= 12.0V, All Black Pattern At 144Hz
IRush	Inrush Current	-	-	3.0	[A]	<b>Note 5-1</b>
VDDrp	Allowable LCD Ripple Voltage	-	-	500	[mV]	VDD= 12.0V, All Black Pattern At 144Hz

*Note 5-1: Measurement conditions:*

Inrush Current measurement:

Test circuit:

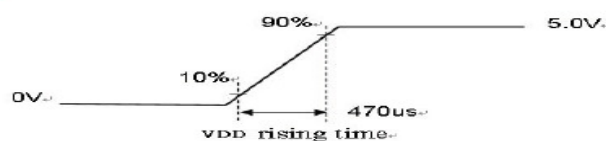
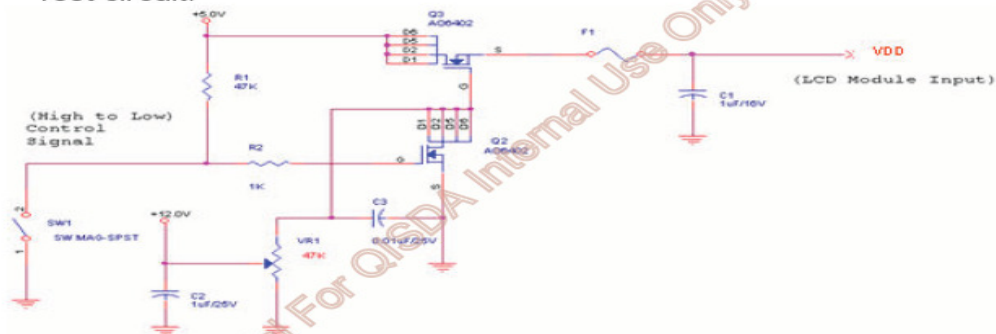

The duration of VDD rising time: 470us.

## 6. Signal Characteristic

### LCD Pixel Format

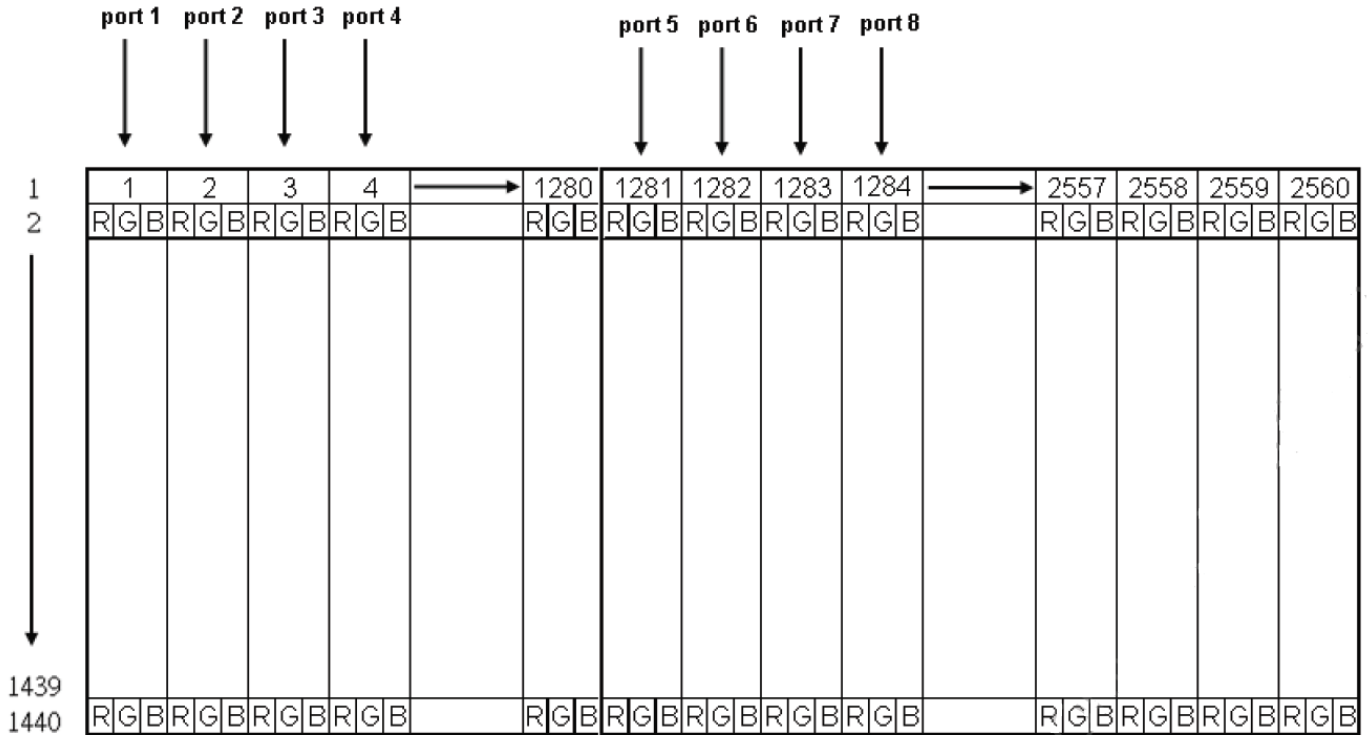

**Note 6-1:** The module use 8 port-LVDS interface.

- Port 1 :  $4N+1$      $N=0, \sim 319$  (1,5.. 1277pixel)
- Port 2 :  $4N+2$      $N=0, \sim 319$  (2,6.. 1278pixel)
- Port 3 :  $4N+3$      $N=0, \sim 319$  (3,7.. 1279pixel)
- Port 4 :  $4N+4$      $N=0, \sim 319$  (4,8.. 1280pixel)
- Port 5 :  $4N+1281$      $N=0, \sim 319$  (1281,1285.. 2557pixel)
- Port 6 :  $4N+1282$      $N=0, \sim 319$  (1282,1286.. 2558pixel)
- Port 7 :  $4N+1283$      $N=0, \sim 319$  (1283,1287.. 2559pixel)
- Port 8 :  $4N+1284$      $N=0, \sim 319$  (1284,1288.. 2560pixel)

## LVDS Data Format

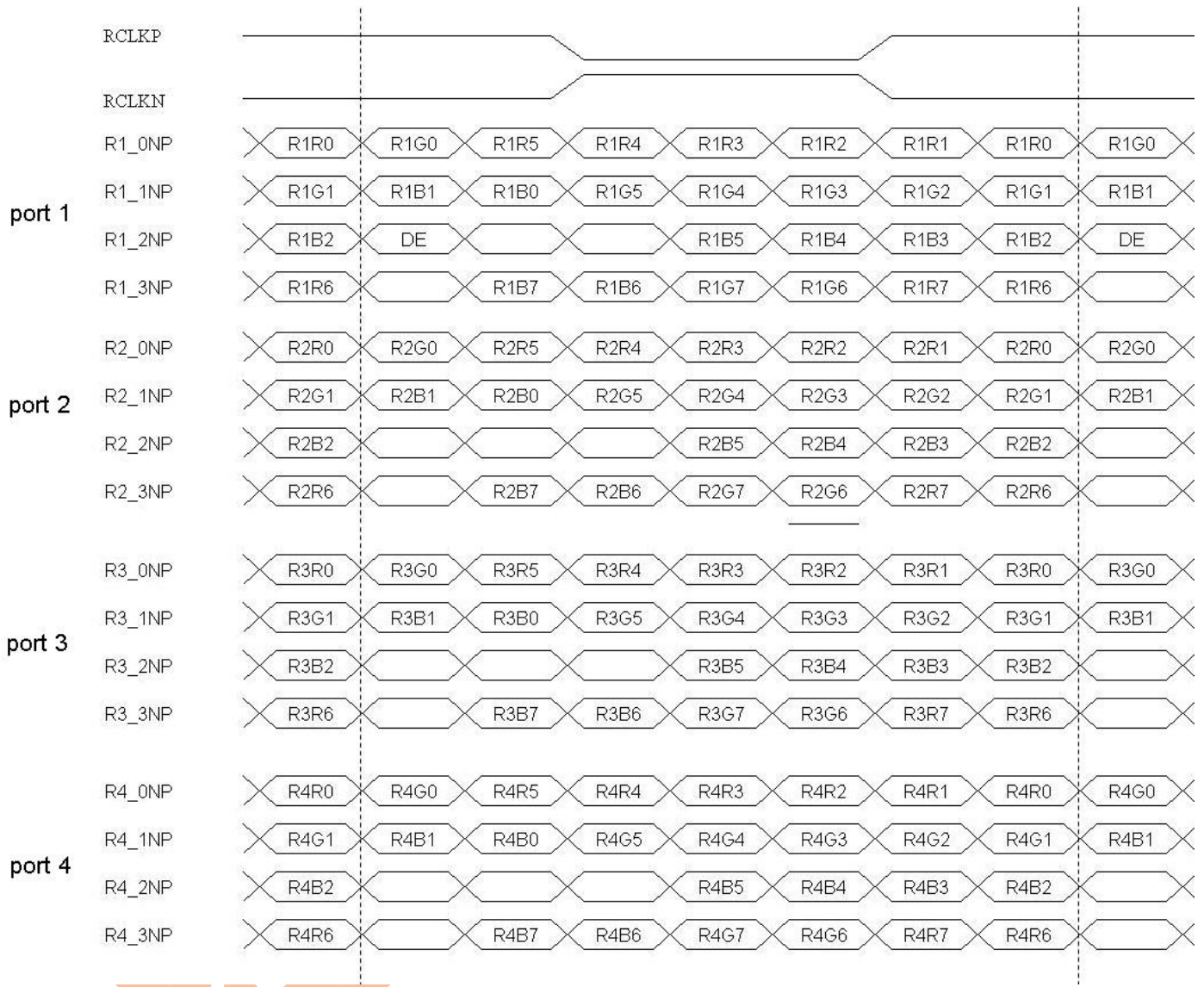

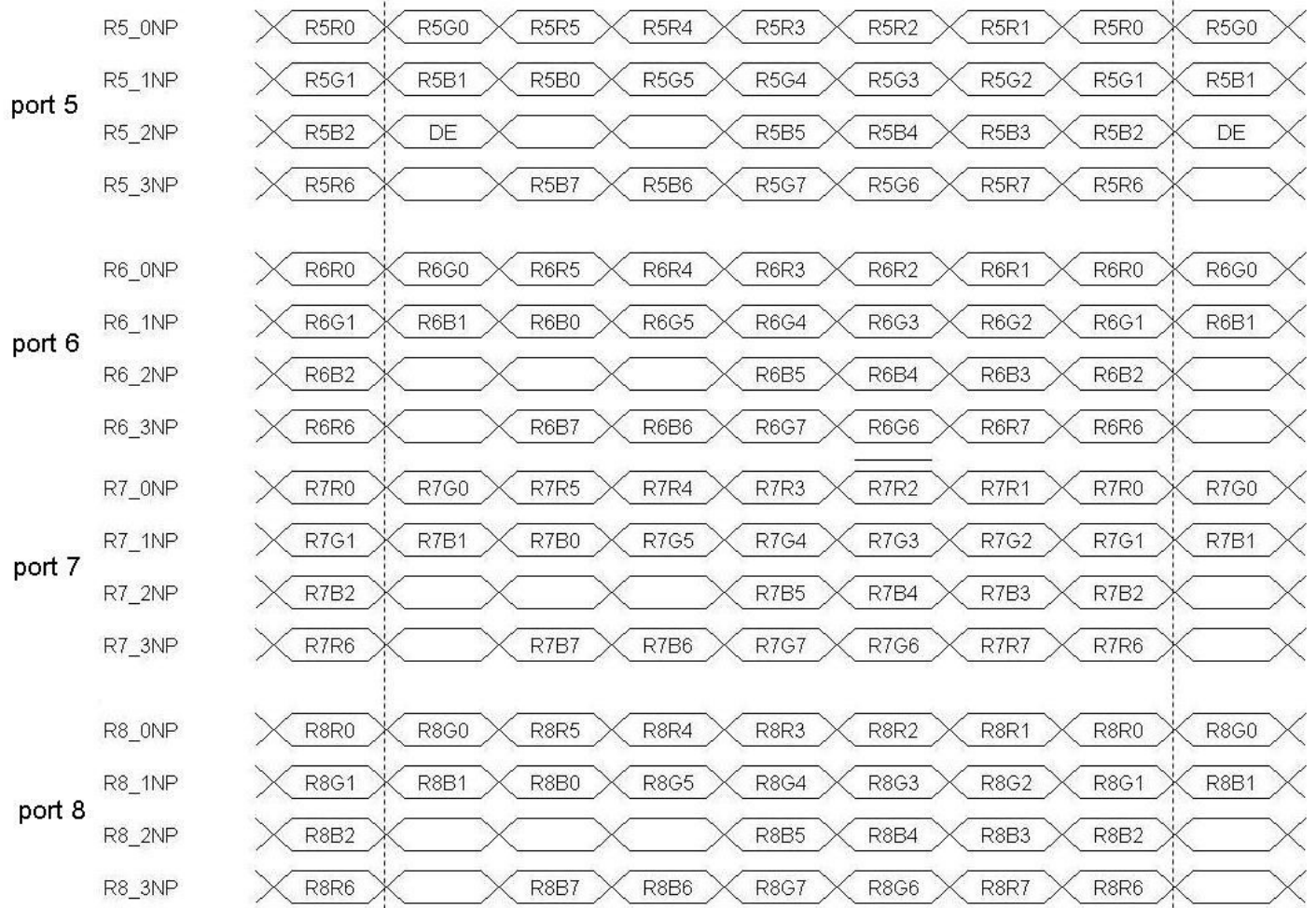

## Color versus Input Data

The following table is for color versus input data (8bit). The higher the gray level, the brighter the color.

Color	Gray Level	Color Input Data																								Remark
		RED data (MSB:R7, LSB:R0)								GREEN data (MSB:G7, LSB:G0)								BLUE data (MSB:B7, LSB:B0)								
		R7	R6	R5	R4	R3	R2	R1	R0	G7	G6	G5	G4	G3	G2	G1	G0	B7	B6	B5	B4	B3	B2	B1	B0	
Black	-	0	0	0	0	0	0	0	0	0	0	0	0	0	0	0	0	0	0	0	0	0	0	0	0	
White	-	1	1	1	1	1	1	1	1	1	1	1	1	1	1	1	1	1	1	1	1	1	1	1	1	
Gray 127	-	0	1	1	1	1	1	1	1	0	1	1	1	1	1	1	1	0	1	1	1	1	1	1	1	
Red	L0	0	0	0	0	0	0	0	0	0	0	0	0	0	0	0	0	0	0	0	0	0	0	0	0	Black
	:	:	:	:	:	:	:	:	:	:	:	:	:	:	:	:	:	:	:	:	:	:	:	:	:	
	L255	1	1	1	1	1	1	1	1	0	0	0	0	0	0	0	0	0	0	0	0	0	0	0	0	
Green	L0	0	0	0	0	0	0	0	0	0	0	0	0	0	0	0	0	0	0	0	0	0	0	0	0	Black
	:	:	:	:	:	:	:	:	:	:	:	:	:	:	:	:	:	:	:	:	:	:	:	:	:	
	L255	0	0	0	0	0	0	0	0	1	1	1	1	1	1	1	1	0	0	0	0	0	0	0	0	
Blue	L0	0	0	0	0	0	0	0	0	0	0	0	0	0	0	0	0	0	0	0	0	0	0	0	0	Black
	:	:	:	:	:	:	:	:	:	:	:	:	:	:	:	:	:	:	:	:	:	:	:	:	:	
	L255	0	0	0	0	0	0	0	0	0	0	0	0	0	0	0	0	1	1	1	1	1	1	1	1	

## LVDS Specification

DC Characteristics of each signal are as following:

Symbol	Parameter	Min	Typ	Max	Units	
$V_{TH}$	Differential Input High Threshold	-	-	+100	mV	VICM = 1.2V Note 1
$V_{TL}$	Differential Input Low Threshold	-100	-	-	mV	VICM = 1.2V Note 1
$ V_{ID} $	Input Differential Voltage	100	-	600	mV	Note 6-2
$V_{CM}$	Differential Input Common Mode Voltage	+1.0	+1.2	+1.5	V	VTH-VTL = 200MV (max) Note 1

Note 6-2: LVDS Signal Waveform

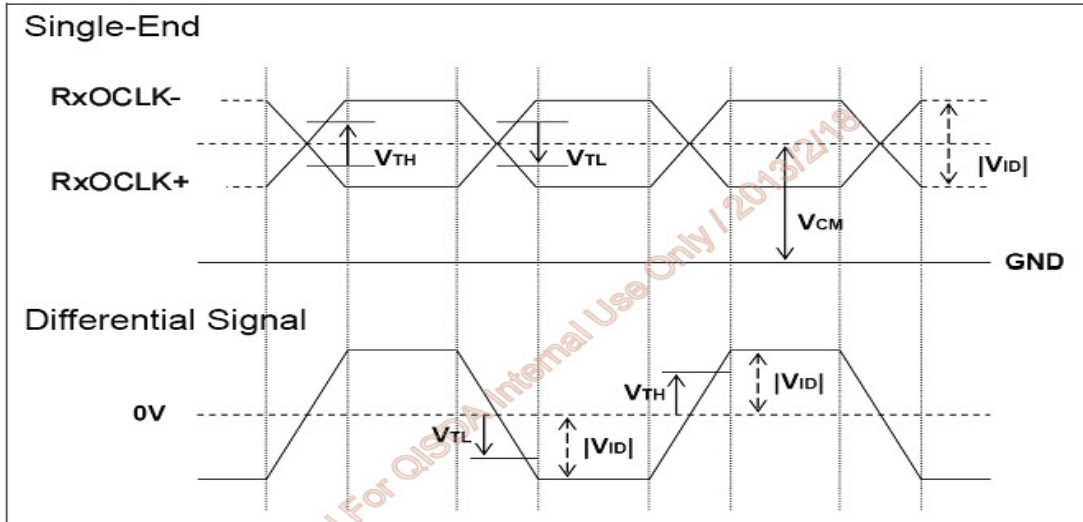

**AC Characteristics**

Symbol	Description	Min	Max	Unit	Remark
$F_{DEV}$	Maximum deviation of input clock frequency during Spread Spectrum	-	$\pm 3$	%	
$F_{MOD}$	Maximum modulation frequency of input clock during Spread Spectrum	-	200	KHz	

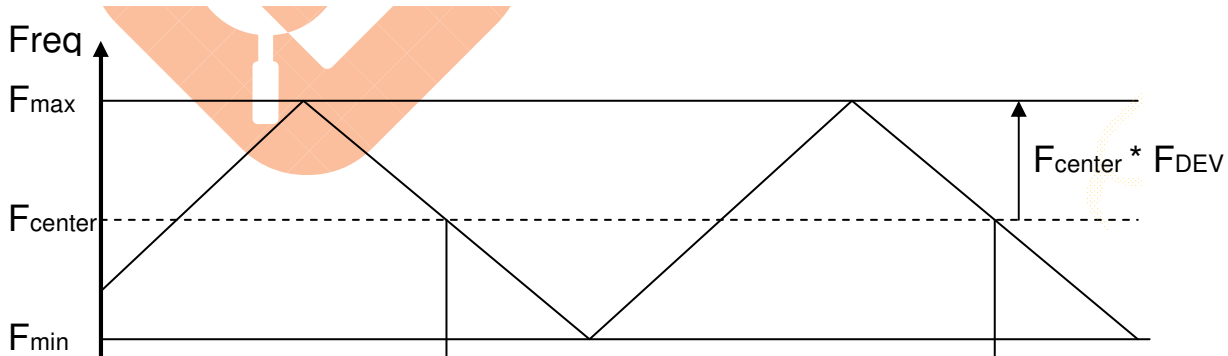

**Input Timing Specification**

It only support DE mode, and the input timing are shown as the following table.

Symbol	Description	$F_{MOD}$ Min	Typ	Max	Unit	Remark
--------	-------------	---------------	-----	-----	------	--------

< Spread Spectrum >

time

Tv	Vertical Section	Period	1452	1481	8192	Th	
Tdisp(v)		Active	1440	1440	1440	Th	
Tblk(v)		Blanking	12	41	6752	Th	
Fv		Frequency	30	120	145	Hz	<b>Note 6-3</b>
Th	Horizontal Section	Period	359	360	1023	Tclk	
Tdisp(h)		Active	320	320	320	Tclk	
Tblk(h)		Blanking	39	40	703	Tclk	
Fh		Frequency	69.7	177.7	250.6	KHz	<b>Note 6-4</b>
Tclk	LVDS Clock	Period	11.1	15.6	39.9	ns	1/Fclk
Fclk		Frequency	25	64	90	MHz	<b>Note 6-5</b>

**Note 6-3:** The optimized setting is 119~145 Hz to driving for good picture quality.

**Note 6-4:** The equation is listed as following. Please don't exceed the above recommended value.

$$Fh (\text{Min.}) = Fclk (\text{Min.}) / Th ((\text{Min.}));$$

$$Fh (\text{Typ.}) = Fclk (\text{Typ.}) / Th (\text{Typ.});$$

$$Fh (\text{Max.}) = Fclk (\text{Max.}) / Th (\text{Min.});$$

**Note 6-5:** The equation is listed as following. Please don't exceed the above recommended value.

$$Fclk (\text{Min.}) = Fv (\text{Min.}) \times Th ((\text{Min.}) \times Tv (\text{Min.}));$$

$$Fclk (\text{Typ.}) = Fv (\text{Typ.}) \times Th ((\text{Typ.}) \times Tv (\text{Typ.}));$$

$$Fv \times Th \times Tv < Fclk (\text{Max.})$$

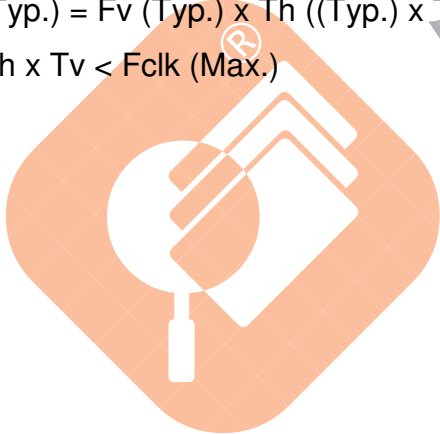

## Input Timing Diagram

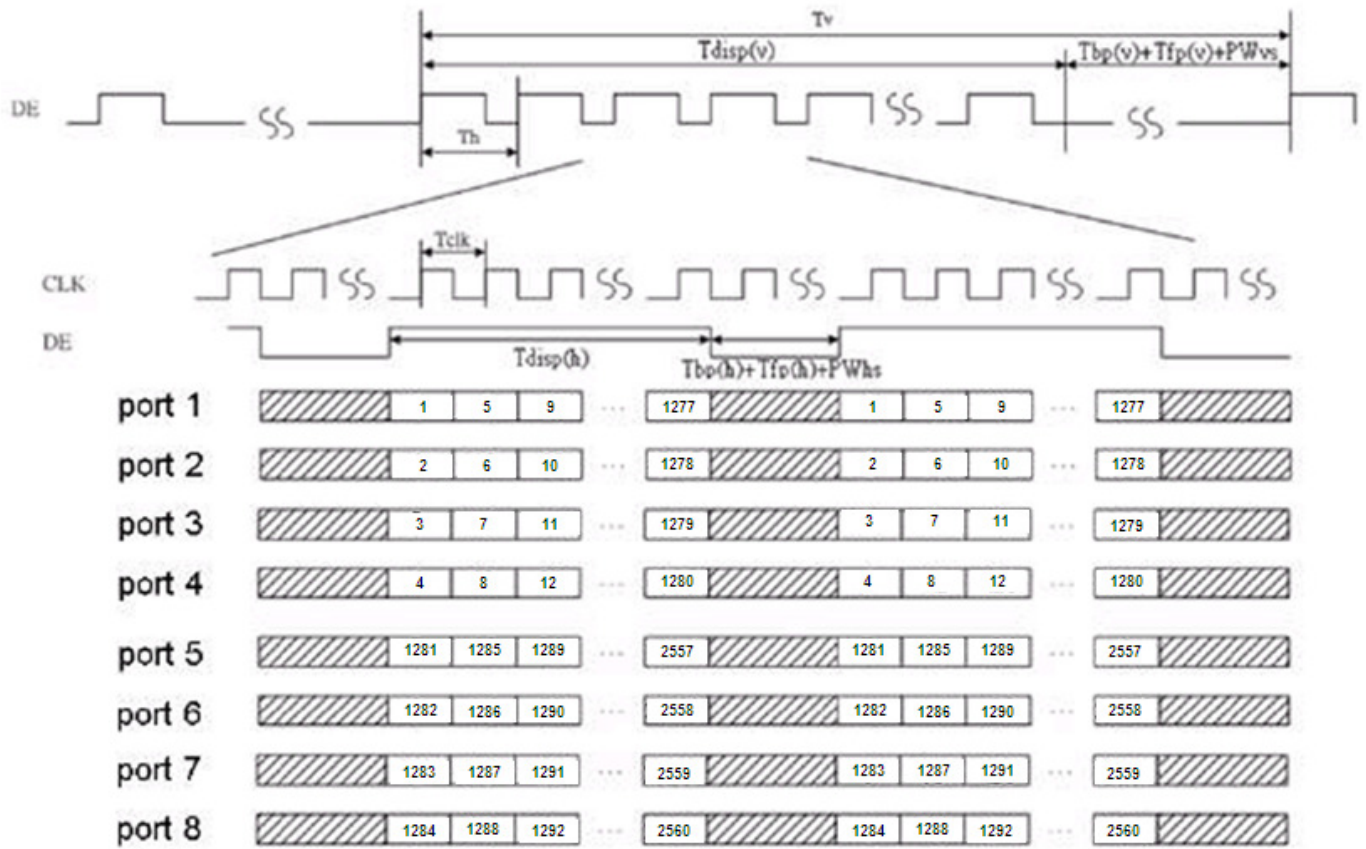

### 3D Control

#### 3D Control I/O Characteristics

Pin#	Symbol	I/O	Buffer	Description	Remark
CN2_pin30	Polarity_SYNC	O	4mA	Frame Inversion polarity Index 3D_EN=L :1-frame inversion 3D_EN=H :2-frame inversion	<b>Note 6-6</b>
CN3_pin30	3D_EN	I	IPL*	3D enable control signal	

IPL:internal pull low

**Note 6-6**



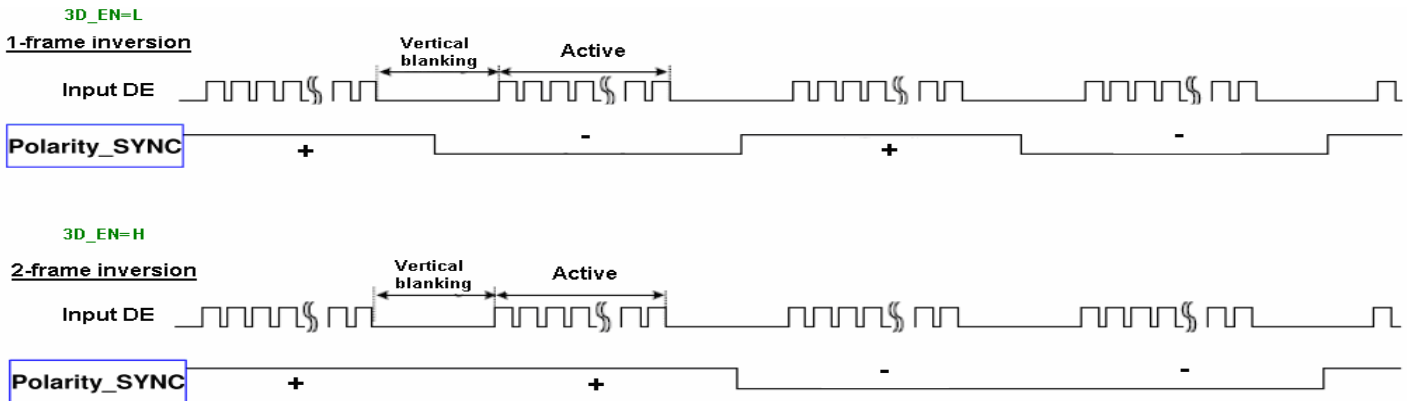

### Absolute Maximum Rating

Symbol	Description	Min	Max	Unit	Remark
3D_EN	3D enable control signal	GND-0.3	5.0	[Volt]	Ta=25

### Recommended Operating Condition

Symbol	Parameter	Condition	Rating			Unit
			Min	Typ	Max	
V <sub>TH</sub>	Input High Voltage		2.0	-	3.6	[V]
V <sub>TL</sub>	Input Low Voltage		0	-	0.8	[V]
V <sub>OH</sub>	Output High Voltage	I <sub>OH</sub> =4mA	2.4	-	3.4	[V]
V <sub>OL</sub>	Output Low Voltage	I <sub>OL</sub> =-4mA	0	-	0.4	[V]

### Power ON/OFF Sequence

VDD power, LVDS signal and backlight on/off sequence are as follows. LVDS signals from any system shall be Hi-Z state when VDD is off.

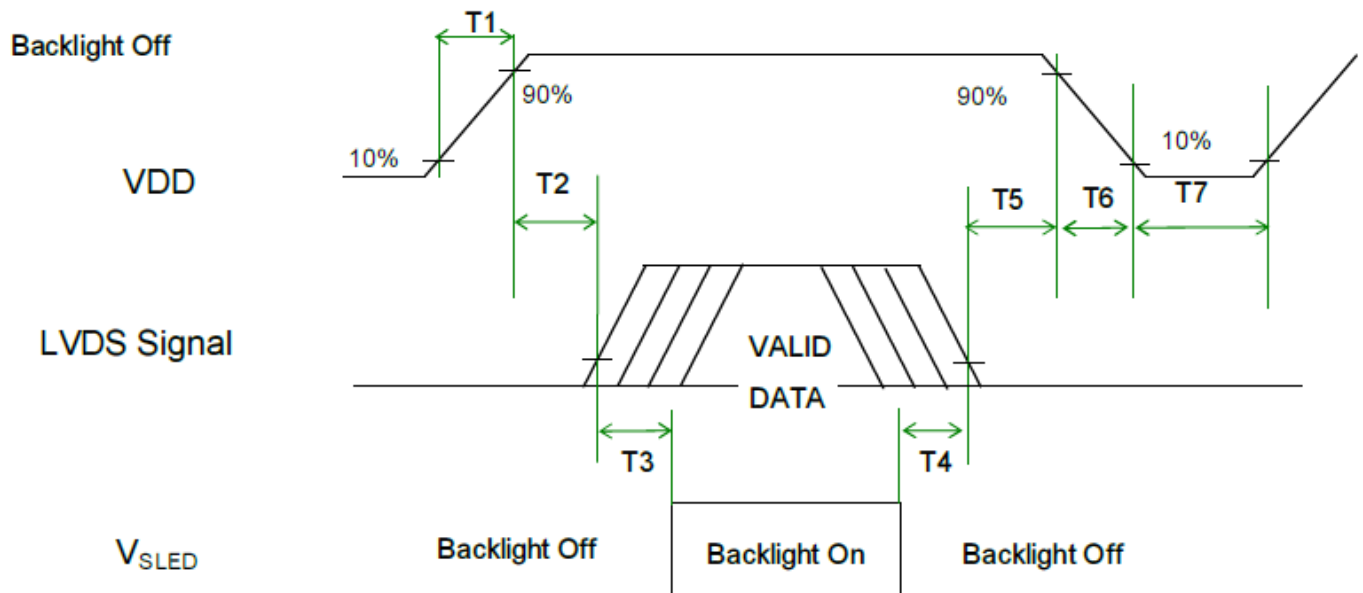

Symbol	Value			Unit	Remark
	Min.	Typ.	Max.		
T1	0.5	-	10	[ms]	
T2	0	-	50	[ms]	
T3	500	-	-	[ms]	
T4	100	-	-	[ms]	
T5	0	-	50	[ms]	<i>Note 6-7</i> <i>Note 6-8</i>
T6	0	-	150	[ms]	<i>Note 6-8</i>
T7	1000	-	-	[ms]	

**Note 6-7 :** Recommend setting T5 = 0ms to avoid electronic noise when VDD is off.

**Note 6-8 :** During T5 and T6 period, please keep the level of input LVDS signals with Hi-Z state.

### Backlight Unit

#### **Block Diagram**

The following shows the block diagram of the 27 inch Backlight Unit. And it includes 72 pcs LED in the LED light bar. (4 strings and 18 pcs LED of one string).

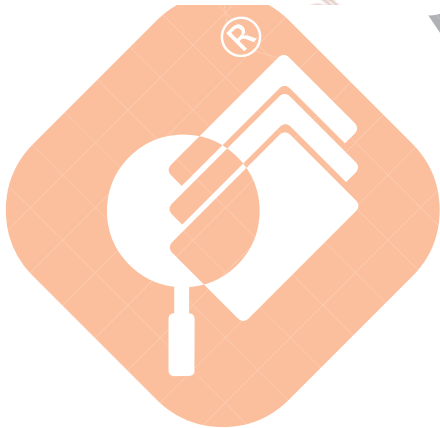
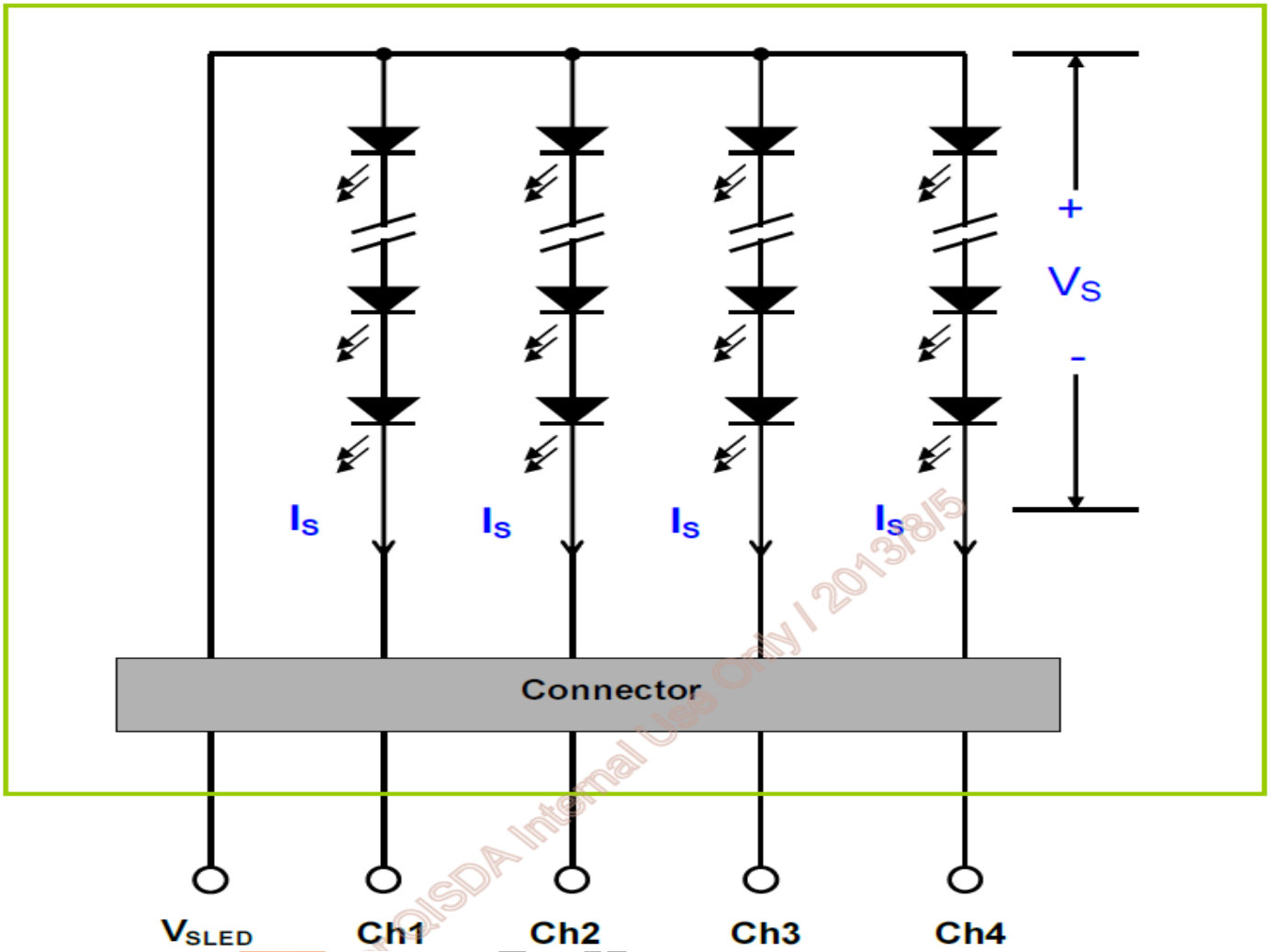

## 7. Connector & Pin Assignment

### TFT LCD Module

<b>TFT-LCD Connector</b>	<b>Manufacturer</b>	STM	Starconn
	<b>Part Number</b>	MSCKT2407P30HB (CN1 / CN2 / CN3)	II5F40-R000RA-M3 (CN4)
<b>Mating Connector</b>	<b>Manufacturer</b>	STM or compatible	JAE or compatible
	<b>Part Number</b>	PK2407P30V	FI-NX40HL

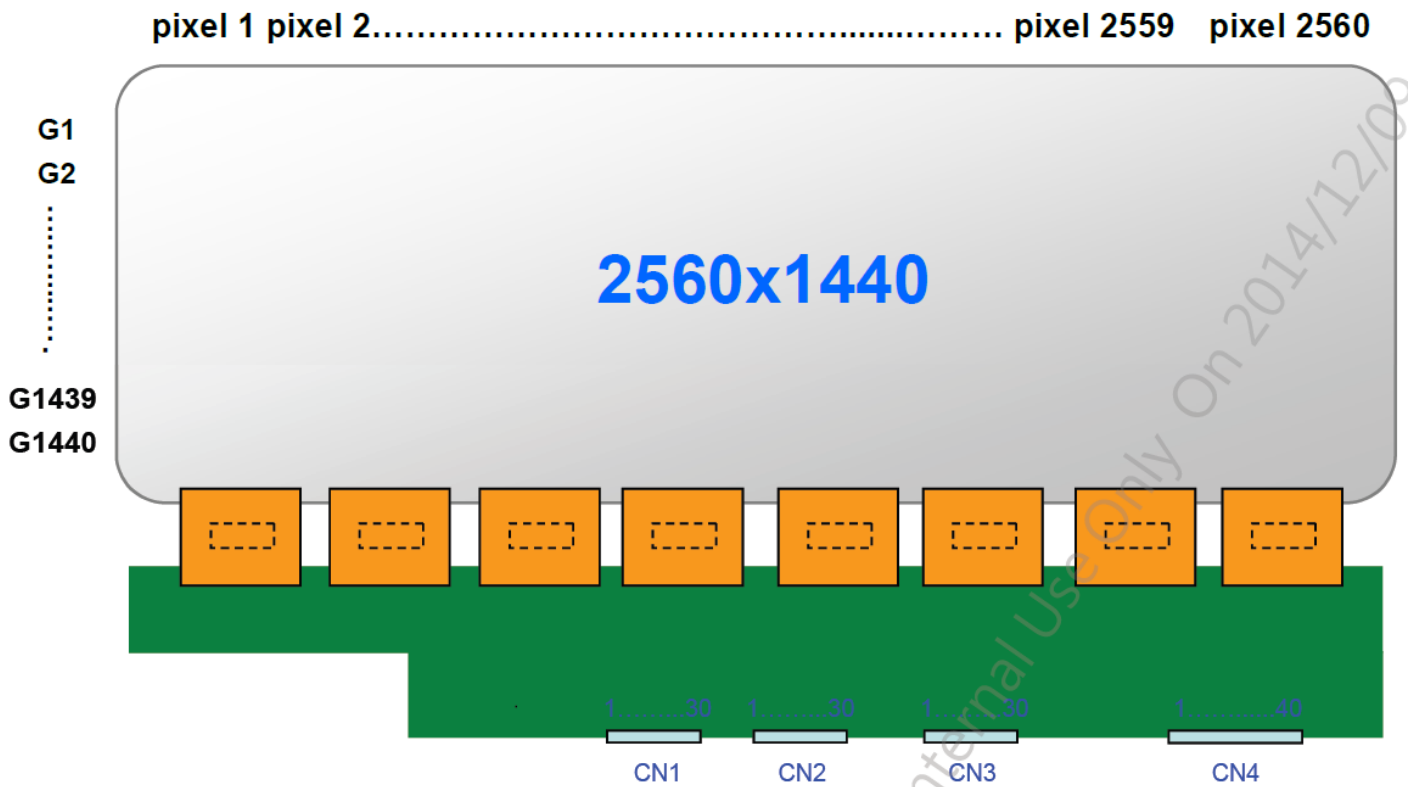

### Connector on Backlight Unit.

This connector is mounted on LED light-bar.

<b>Backlight Connector</b>	<b>Manufacturer</b>	CVILUX
	<b>Part Number</b>	CII406MIVL0-NH
<b>Mating Connector</b>	<b>Manufacturer</b>	ENTERY
	<b>Part Number</b>	HI12K-P06N-00B (Non-Locking type) HI12K-P06N-11B(White) (Lockingtype) HI12K-P06N-13B(Black) (Lockingtype)

Physical interface is described as for the connector on module. These connectors are capable of accommodating the following signals and will be following components.

**LED connector Pin assignment**

Pin no.	Signal name
1	IRLED (current out)
2	IRLED (current out)
3	VLED (voltage in)
4	VLED (voltage in)
5	IRLED (current out)
6	IRLED (current out)

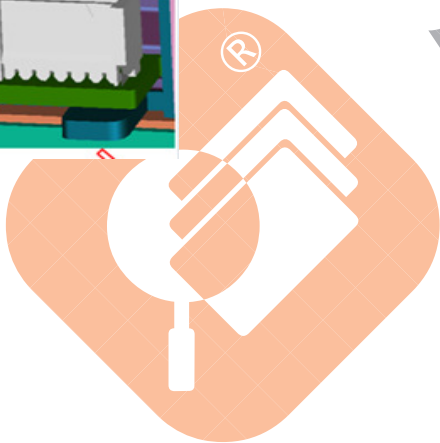
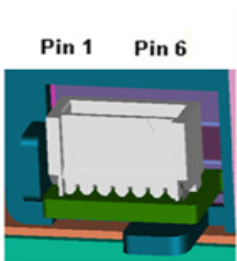

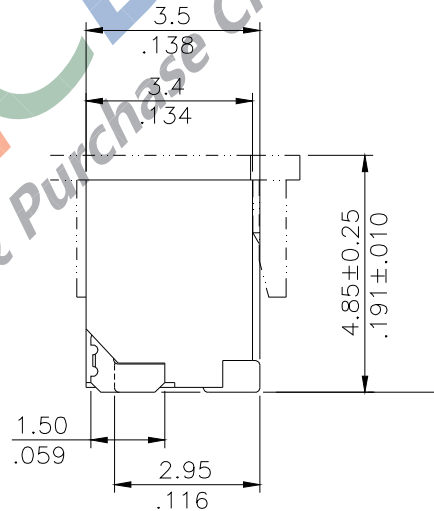
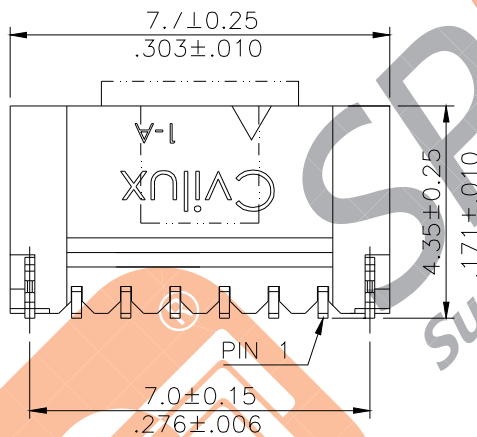
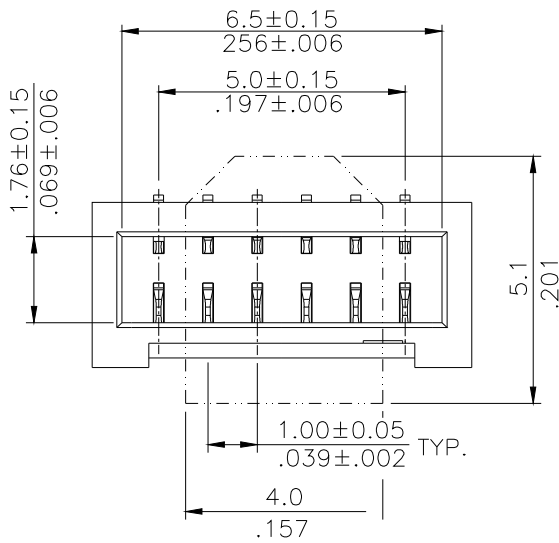

### Connector Pin Assignment

Pin#	Symbol	Description	Remark
1	Ch1	LED Current Feedback Terminal (Channel 1)	
2	Ch2	LED Current Feedback Terminal (Channel 2)	
3	V <sub>SLED</sub>	LED Power Supply Voltage Input Terminal	
4	V <sub>SLED</sub>	LED Power Supply Voltage Input Terminal	
5	Ch3	LED Current Feedback Terminal (Channel 3)	
6	Ch4	LED Current Feedback Terminal (Channel 4)	

## Electrical Characteristics

### Absolute Maximum Rating

Parameter damage may occur if exceeding the following maximum rating.

Symbol	Description	Min.	Max.	Unit	Remark
Is	LED String Current	0	150	[mA]	100% duty ratio
			210	[mA]	Duty ratio 10% Pulse time=10ms

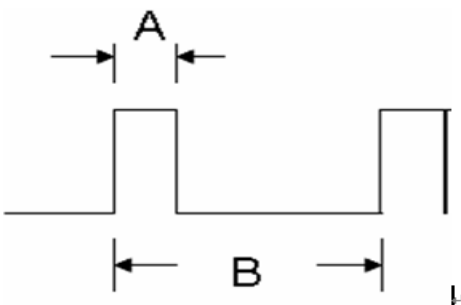

Duty ratio = (A / B) X 100% ; (A: Pulse time, B: Period).

Parameter guideline for LED driving is under stable conditions at 25°C (Room Temperature):

Symbol	Parameter	Min.	Typ.	Max.	Unit	Note
IR <sub>LED</sub>	LED Operation Current	-	120	132	[mA]	Operating with fixed driving current
V <sub>LB</sub>	Light Bar Operation Voltage (for reference)	53.1	56.7	64.8	[Volt] Note 7-1 Note 7-5	
ΔVs	Maximum Vs Voltage Deviation of light bar	-	-	3.6	[Volt] Note 7-2	
P <sub>BLU</sub>	BLU Power consumption (for reference)		27.2	31.1	[Watt] Note 7-3	
LT <sub>LED</sub>	LED life Time (Typical)	30,000		-	[Hour] Note 7-4	

**Note 7-1:** Vs (Typ.) = VF (Typ.) X LED No. (one string);

a. VF: LED chip forward voltage, VF (Min.)=2.95V, VF(Typ.)=3.15V, VF(Max.)=3.6V

b. The same equation to calculate Vs(Min.) & Vs (Max.) for respective VF (Min.) & VF(Max.);

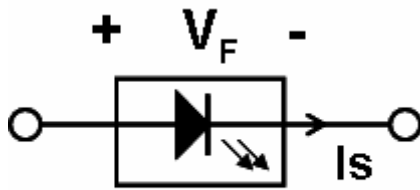

**LED chip**

**Note 7-2:**  $\Delta V_s$  (Max.) =  $\Delta V_F \times \text{LED No. (one string)}$ ;

a.  $\Delta V_F$ : LED chip forward voltage deviation; (0.2 V , each Bin of LED VF)

**Note 7-3:**  $P_{BLU}$  (Typ.) =  $V_s$  (Typ.)  $\times I_s$  (Typ.)  $\times 4$  ; ( 4 is total String No. of LED Light bar)

$P_{BLU}$  (Max.) =  $V_s$  (Max.)  $\times I_s$  (Typ.)  $\times 4$  ;

**Note 7-4:** Definition of life time:

a. Brightness of LED becomes to 50% of its original value

b. Test condition:  $I_s = 120\text{mA}$  and  $25^\circ\text{C}$  (Room Temperature)

**Note 7-5:** Recommendation for LED driver power design:

Due to there are electrical property deviation in LED & monitor set system component after long time operation. AUO strongly recommend the design value of LED driver board OVP (over voltage protection) should be 10% higher than max. value of LED string voltage ( $V_s$ ) at least.

**Note 7-6:** AUO strongly recommend “Analog Dimming” method for backlight brightness control for Wavy Noise Free. Otherwise, recommend that Dimming Control Signal (PWM Signal) should be synchronized with Frame Frequency.





## Timing diagram

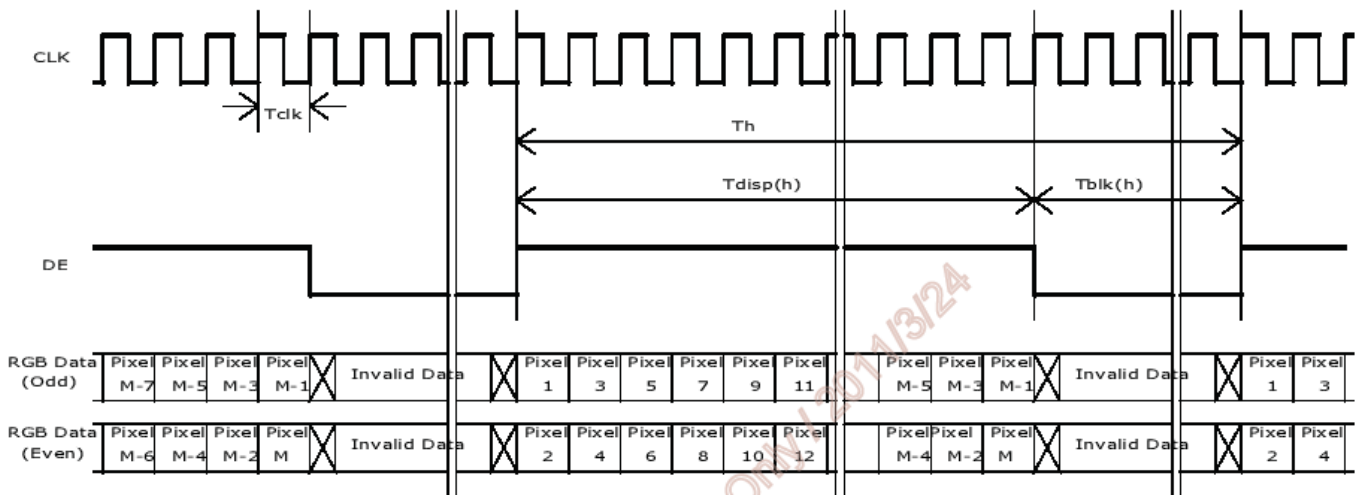
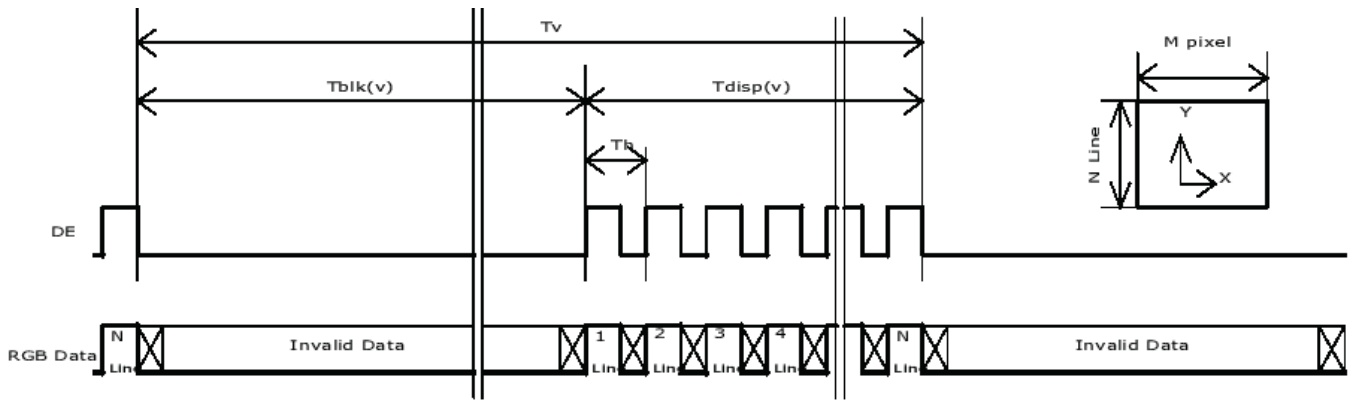

## Power ON/OFF Sequence

VDD power, LVDS signal and backlight on/off sequence are as follows. LVDS signals from any system shall be Hi-Z state when VDD is off.

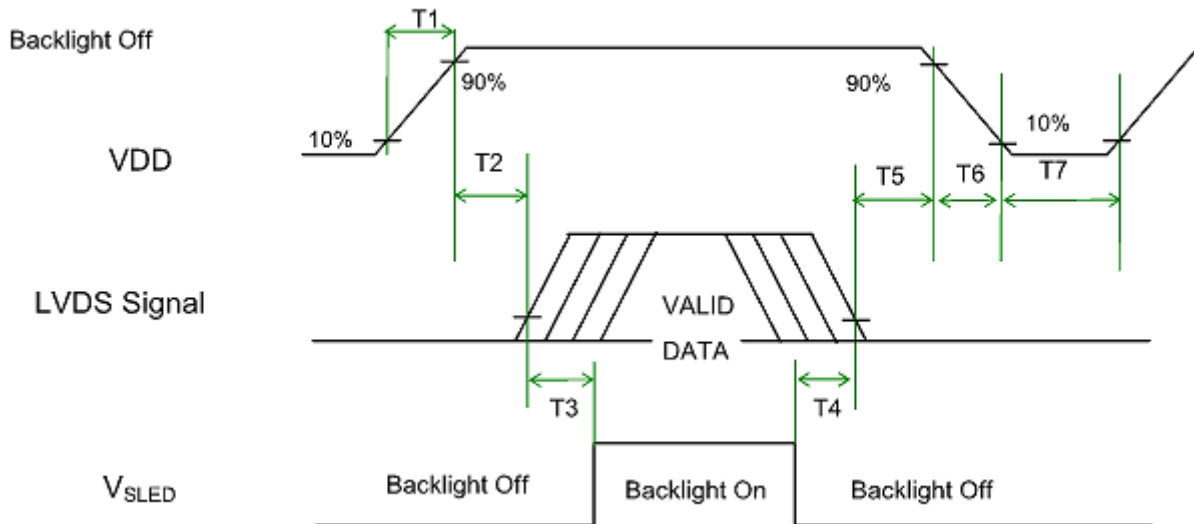

Parameter	Value		Unit
	Min.	Max.	
T1	0.5	10	[ms]
T2	0	50	[ms]
T3	500	-	[ms]
T4	100	-	[ms]
T5	0	50	[ms]
T6	0	150	[ms]
T7	1000	-	[ms]

**Note1** : Recommend setting T5 = 0ms to avoid electronic noise when VDD is off.

**Note2** : During T5 and T6 period , please keep the level of input LVDS signals with Hi-Z state.

## 8. Reliability Test

Environment test conditions are listed as following Monitor test condition.

Items	Condition	Remark
Temperature Humidity Bias (THB)	Ta= 50°C , 80%RH, 300hours	
High Temperature Operation (HTO)	Ta= 50°C , 50%RH, 300hours	
Low Temperature Operation (LTO)	Ta= 0°C , 300hours	
High Temperature Storage (HTS)	Ta= 60°C , 300hours	
Low Temperature Storage (LTS)	Ta= -20°C , 300hours	
Vibration Test (Non-operation)	Acceleration: 1.5 Grms Wave: Random Frequency: 10 - 200 Hz Sweep: 30 Minutes each Axis (X, Y, Z)	
Shock Test (Non-operation)	Acceleration: 50 G Wave: Half-sine Active Time: 20 ms Direction: ±X, ±Y, ±Z (one time for each Axis)	
Thermal Shock Test (TST)	-20°C/30min, 60°C/30min, 100 cycles	<b>Note 8-1</b>
On/Off Test	On/10sec, Off/10sec, 30,000 cycles	
ESD (Electro Static Discharge)	Contact Discharge: ± 15KV, 150pF(330Ω ) 1sec, 8 points, 25 times/ point.	<b>Note 8-2</b>
	Air Discharge: ± 15KV, 150pF(330Ω ) 1sec 8 points, 25 times/ point.	
Altitude Test	Operation:18,000 ft Non-Operation:40,000 ft	

Note 8-1: The TFT-LCD module will not sustain damage after being subjected to 100 cycles of rapid temperature change. A cycle of rapid temperature change consists of varying the temperature from -20°C to 60°C, and back again. Power is not applied during the test. After temperature cycling, the unit is placed in normal room ambient for at least 4 hours before power on.

Note8- 2: According to EN61000-4-2 , ESD class B: Certain performance degradation allowed:  
No data lost. Self-recoverable. No hardware failures.\

## 9. Shipping label

The label is on the panel as shown below:

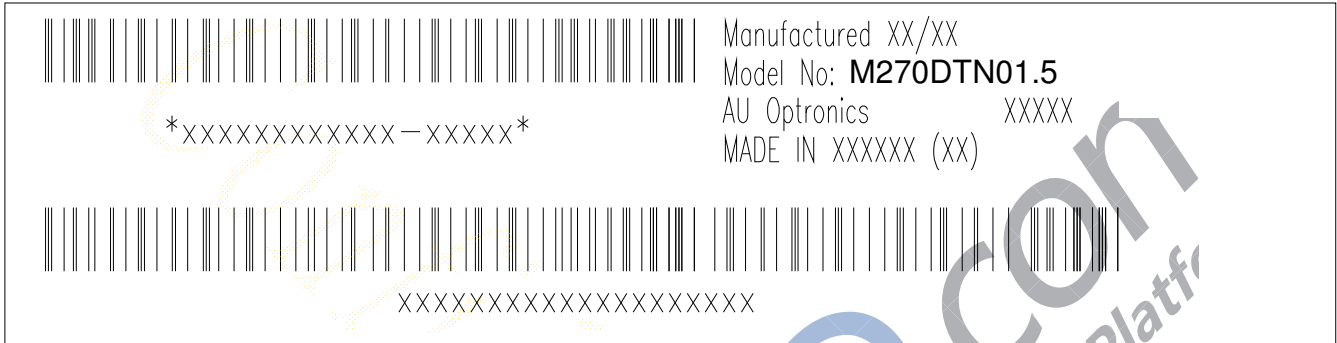

**Note 6-1:** For Pb Free products, AUO will add  for identification.

**Note 6-2:** For RoHS compatible products, AUO will add  for identification.

**Note 6-3:** For China RoHS compatible products, AUO will add  for identification.

**Note 6-4:** The Green Mark will be presented only when the green documents have been ready by AUO Internal Green Team.



## 10. Packing Precautions

TFT-LCD Module (or monitor) should stand or be placed face up in traffic or storage conditions; please do not keep TFT-LCD Module face down (polarizer side down).

Monitor maker should add the notice above in packing description; See the configuration example as below:

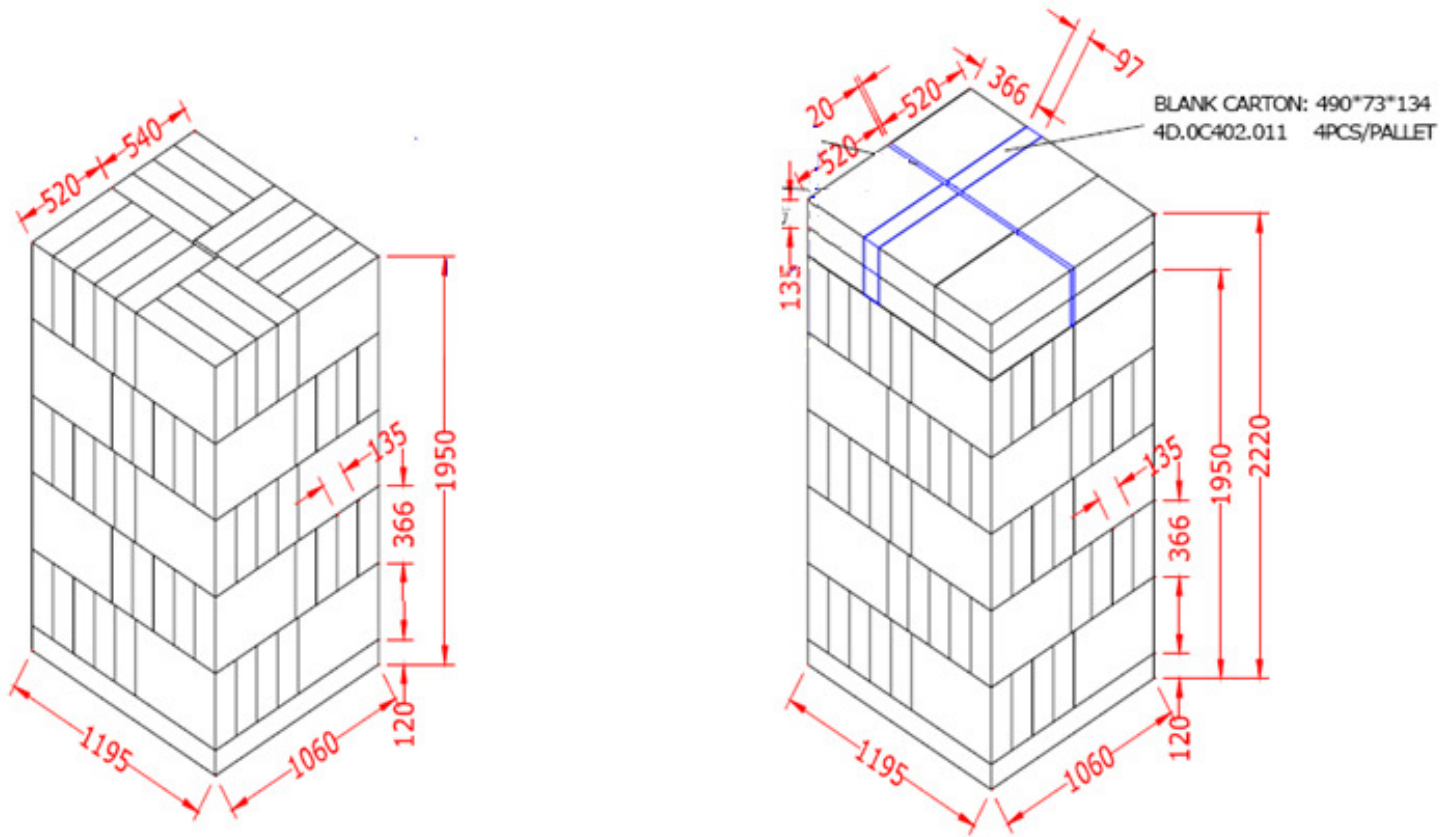

Note:  
 Front Bezel Coating SPEC  
 Color: Standard Black; Material: SECC 0.5T; Finishing: Flat Matt; Glass: 25+/-5; Coating thickness: 40+/-20um

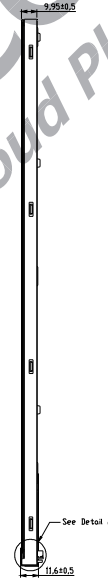
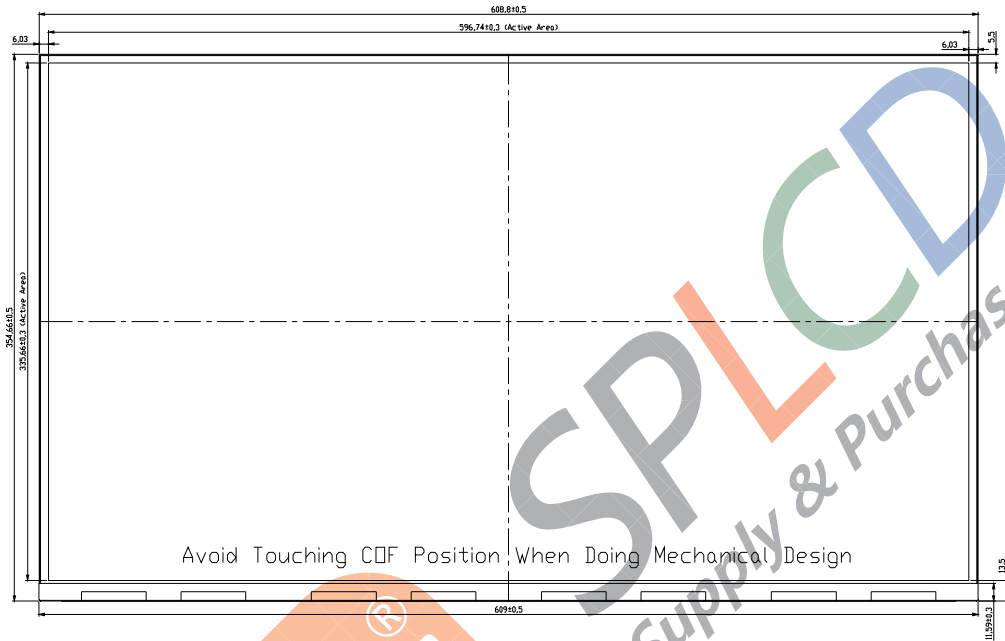

Double Side Tape 0.2T  
 Peeling Strength: >1500gf/inch

SECC 0.5T

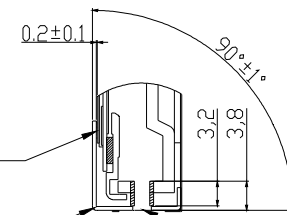

Detail A  
 Scale 5:1

MODEL	NAME	TOLERANCE UNLESS OTHERWISE SPECIFIED (±)							
		CLASS	A	B	C	D	E	F	G
DRN	MATERIAL	< 8mm	005	01	01	02	02	04	04
DSN	FINISH	8 - 25mm	008	015	015	03	03	05	06
CKD	SCALE	25 - 80mm	012	02	025	04	05	08	10
APPD	SHEET OF CAVITIES	80 - 250mm	025	03	04	06	08	12	15
		250 - 800mm	05	06	08	10	15	20	30
		> 800mm	10	10	15	17	30	40	44
		ANGLE	05						
Qisda Corporation		FILE NAME							
		PART NO.							

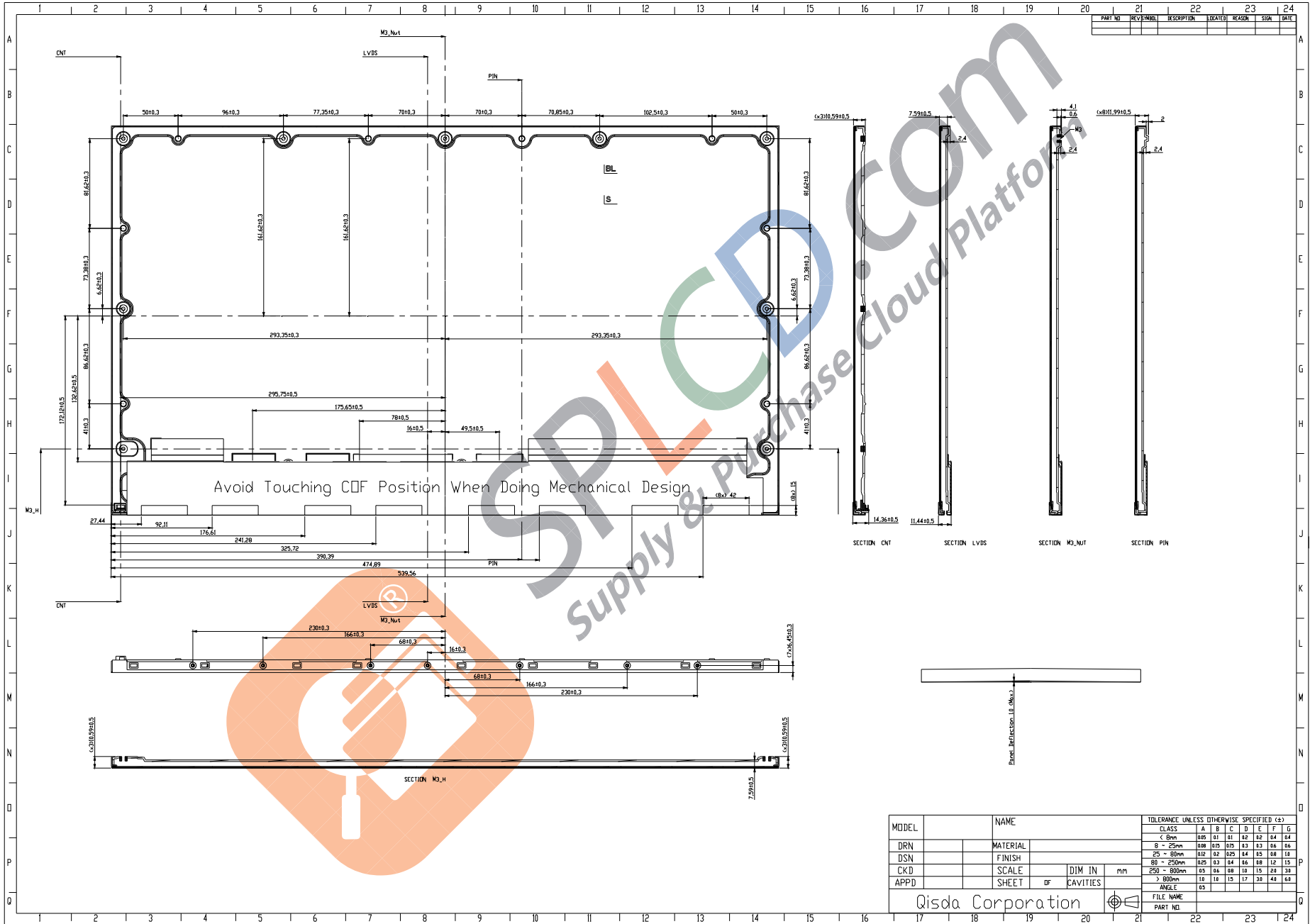

PART NO	REV	NO	DESCRIPTION	LOCAL	REASON	SHA	DATE

MODEL	NAME		TOLERANCE UNLESS OTHERWISE SPECIFIED (+/-)									
	CLASS		A	B	C	D	E	F	G			
DRN		MATERIAL	0.05	0.1	0.1	0.2	0.2	0.4	0.4			
DSN		FINISH	0.08	0.15	0.15	0.2	0.2	0.4	0.6			
CKD		SCALE	0.12	0.2	0.25	0.4	0.5	0.8	1.0			
APPD		SHEET OF CAVITIES	0.25	0.3	0.4	0.6	0.8	1.2	1.5			
			0.5	0.6	0.8	1.0	1.5	2.0	2.5			
			1.0	1.0	1.5	1.7	2.0	2.5	3.0			
			0.5									

Qisda Corporation