

ZipWirePlus™ G.shdsl Transceiver with Embedded Microprocessor

M28945

Complete G.shdsl/HDSL2/SDSL Multi-Rate DSL Solution

Multimode Operation

The ZipWirePlus single-port multimode DSL solution not only complies with the ITU G.shdsl standard; it also supports the optional enhanced performance asymmetrical PSD (EPAP) modes of operation. In addition, it complies with the ANSI HDSL2 standard (ANSI T1.418) and delivers interoperability with Mindspeed Technologies'™ market-leading ZipWire™ transceivers through operation in 2B1Q multi-rate mode. The 2B1Q mode supports AutoBaud™ for SDSL interoperability, rate optimization and fast connect times. The ZipWirePlus also supports Mindspeed's proprietary modes (such as 32-PAM, 4.6 Mbps operation) which provides high-speed operation. All of these modes are supported by a single hardware circuit (i.e., one transformer, crystal and hybrid for all modes) and can be configured in real time via software control.

Embedded Microprocessor

The ZipWirePlus chipset includes an embedded microprocessor and a full suite of software that facilitates speedy and simplified development of systems that comply with all applicable ITU, ANSI and ETSI standards. The embedded microprocessor and software handle the EOC processing and many other functions often delegated to an external host controller in competing solutions. This greatly reduces software-porting efforts and eliminates real-time processing requirements for an external host controller.

Flexible Framer

The ZipWirePlus's integrated T1/E1 framer supports two PCM interfaces, each capable of managing up to 72

KEY FEATURES

- › Single-port CPE solution
- › Multimode operation
- › Low power consumption
- › Highly integrated solution
- › Embedded microprocessor
- › Operation up to 4.6MB
- › Dual PCM interfaces (Narrowband)
- › Interoperable with ZipWire 2B1Q transceivers including AutoBaud

timeslots. The UTOPIA level 2 interface provides ATM TC-layer processing. The framer automatically extracts and inserts DSL overhead (i.e., EOC, indicator and Z-bits, CRC, sync word, etc.) and passes it on to the embedded microprocessor. All G.shdsl, HDSL2, and SDSL frame formats and EOC messaging protocols are supported, as well as other non-standard SDSL frame formats, including framer bypass mode.

Full System Solution

The ZipWirePlus includes an integrated frequency synthesizer to provide a full DSL solution. The frequency synthesizer, along with the rest of the ZipWirePlus, supports data rates from 192 Kbps to 4.6 Mbps, and requires only one external crystal. This highly integrated DSL solution enables OEMs to design and manufacture the most feature-rich, lowest-power and highest-density DSL equipment in the industry.

The matching M28927-29 Analog Front End/Line Driver (AFE/LD) is capable of driving the high line-power EPAP modes for payload rates of 768; 1,544; 2,048 and 2,304 Kbps, as specified by the G.shdsl standard.

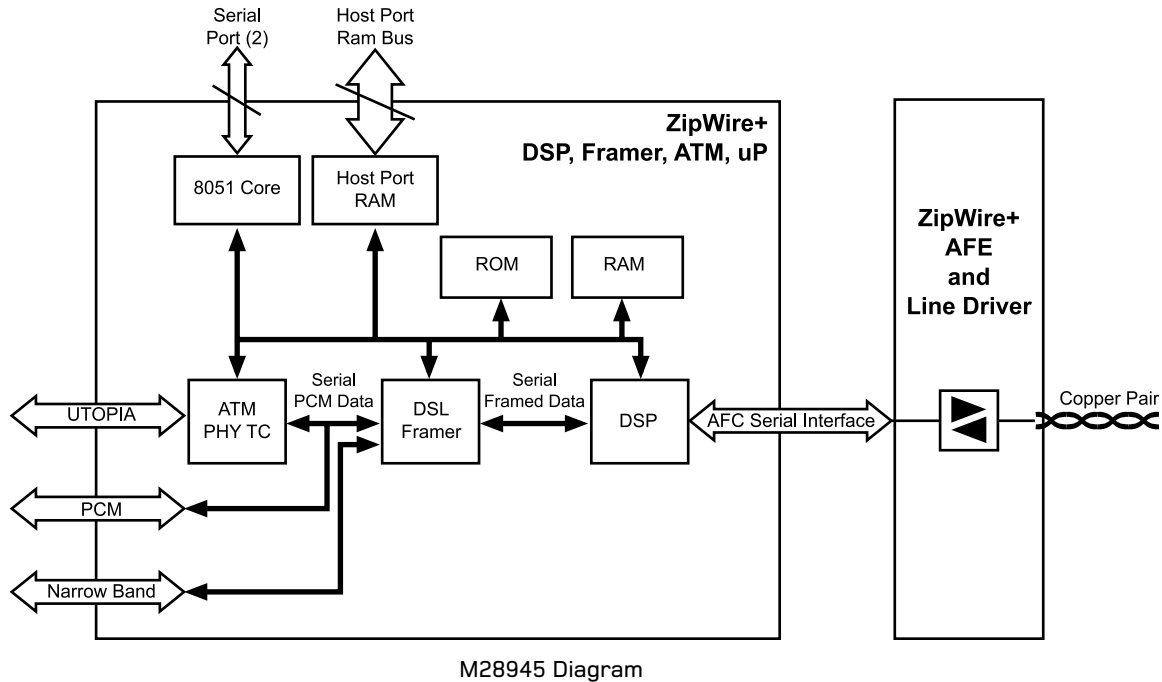

Product Features

- Operating modes supported:
 - ITU G.shdsl including EPAP modes (ITU G.991.2)
 - ITU G.handshake (ITU G.994.1)
 - HDSL2 (ANSI T1.418)
 - SDSL/2B1Q (AutoBaud)
 - Proprietary/extended reach (ANSI spectrum management for loop transmission systems)
 - Proprietary/high-speed (ANSI spectrum management for loop transmission systems)
- Highly integrated solution including framer, microprocessor, ROM/RAM, frequency synthesizer, and DSP
- Two packaging options for high density and manufacturability
 - Option A (two-package):
 - DSP/Framer/uP = 13x13 mm CABGA;
 - AFE/LD = 7x7 mm LGA
 - Option B (two package):
 - DSP/Framer/uP = 24x24 mm LQFP;
 - AFE/LD = 7 x 7 LGA
- Embedded microprocessor for autonomous operation and EOC processing
- Data rates from 192 Kbps to 4.6 Mbps in 8 Kbps increments
- Central office (COT) and remote (RT) operation
- Glueless interface to popular microprocessors
- Single hardware circuit supports all speeds and modes of operation
- +1.8 V, and +3.3 V
- JTAG boundary scan
- Operation over full industrial temperature range (-40° C to +85° C) Applications
- DSL-enabled customer premises equipment (CPE)
- Integrated access devices (IADs)
- Digital subscriber line access multiplexers (DSLAMs)
- N-Channel DAML and voice pair gain systems
- Nx64K data transport
- Remote LAN access
- T1 and E1 HDSL-enabled transport systems
- Cellular base station data links
- Campus modems
- Data, voice and video transport systems

www.mindspeed.com/salesoffices
 General Information: (949) 579-3000
 Headquarters – Newport Beach
 4000 MacArthur Blvd., East Tower
 Newport Beach, CA 92660-3007
 28945-BRF-001-A M03-0763

© 2002 Mindspeed Technologies™, a Conexant business. All rights reserved. Mindspeed and the Mindspeed logo are trademarks of Mindspeed Technologies. All other trademarks are the property of their respective owners. Although Mindspeed Technologies strives for accuracy in all its publications, this material may contain errors or omissions and is subject to change without notice. **This material is provided as is and without any express or implied warranties, including merchantability, fitness for a particular purpose and non-infringement.** Mindspeed Technologies shall not be liable for any special, indirect, incidental or consequential damages as a result of its use.

MINDSPEED™
 A CONEXANT BUSINESS