

NPN Silicon Epitaxial Planar Transistor

M28S

FEATURES

- Excellent H_{FE} Linearity.
- High DC current gain.
- High Power Dissipation.



APPLICATIONS

- Audio output driver amplifier.
- General purpose switch.

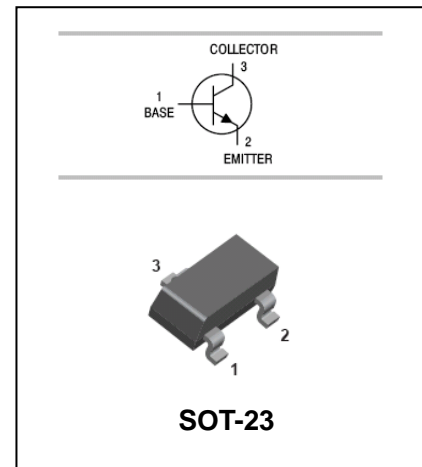

ORDERING INFORMATION

Type No.	Marking	Package Code
M28S	28S	SOT-23

MAXIMUM RATING @ $T_a=25^{\circ}\text{C}$ unless otherwise specified

Symbol	Parameter	Value	Units
V_{CBO}	Collector-Base Voltage	40	V
V_{CEO}	Collector-Emitter Voltage	20	V
V_{EBO}	Emitter-Base Voltage	6	V
I_C	Collector Current -Continuous	1	A
I_B	Base current	0.4	A
P_C	Collector Power Dissipation	200	mW
T_j, T_{stg}	Junction and Storage Temperature	-55 to +150	$^{\circ}\text{C}$



NPN Silicon Epitaxial Planar Transistor

M28S

ELECTRICAL CHARACTERISTICS @ Ta=25°C unless otherwise specified

Parameter	Symbol	Test conditions	MIN	TYP	MAX	UNIT
Collector-base breakdown voltage	$V_{(BR)CBO}$	$I_C=100\mu A, I_E=0$	40			V
Collector-emitter breakdown voltage	$V_{(BR)CEO}$	$I_C=1mA, I_B=0$	20			V
Emitter-base breakdown voltage	$V_{(BR)EBO}$	$I_E=100\mu A, I_C=0$	6			V
Collector cut-off current	I_{CBO}	$V_{CB}=35V, I_E=0$			0.1	μA
Emitter cut-off current	I_{EBO}	$V_{EB}=5V, I_C=0$			0.1	μA
DC current gain	h_{FE}	$V_{CE}=1V, I_C=1mA$	290		1000	
		$V_{CE}=1V, I_C=0.1A$	300			
		$V_{CE}=1V, I_C=0.3A$	300			
		$V_{CE}=1V, I_C=0.5A$	300			
Collector-emitter saturation voltage	$V_{CE(sat)}$	$I_C=600mA, I_B=20mA$			0.55	V
Transition frequency	f_T	$V_{CE}=10V, I_C=50mA,$ $f=1MHz$	100			MHz
Collector output capacitance	C_{ob}	$V_{CB}=10V, I_E=0, f=1MHz$		9		pF

CLASSIFICATION OF h_{FE2}

Rank	B	C	D
Range	300-550	500-700	650-1000

NPN Silicon Epitaxial Planar Transistor

M28S

TYPICAL CHARACTERISTICS @ Ta=25°C unless otherwise specified

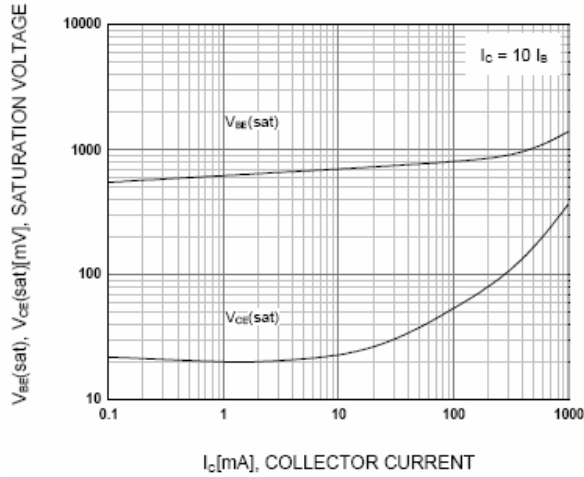

**Figure 1. Base-Emitter Saturation Voltage
Collector-Emitter Saturation Voltage**

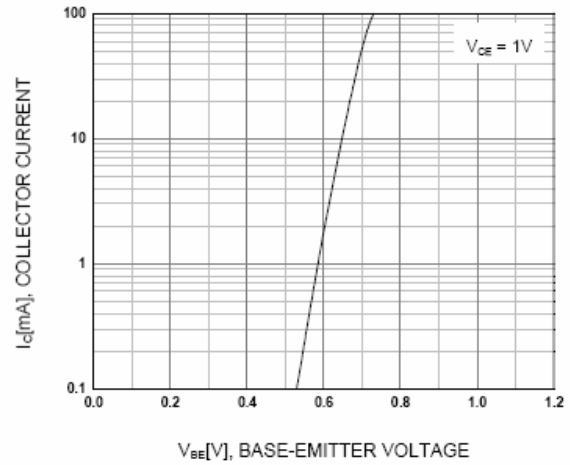

Figure 2. Base-Emitter On Voltage

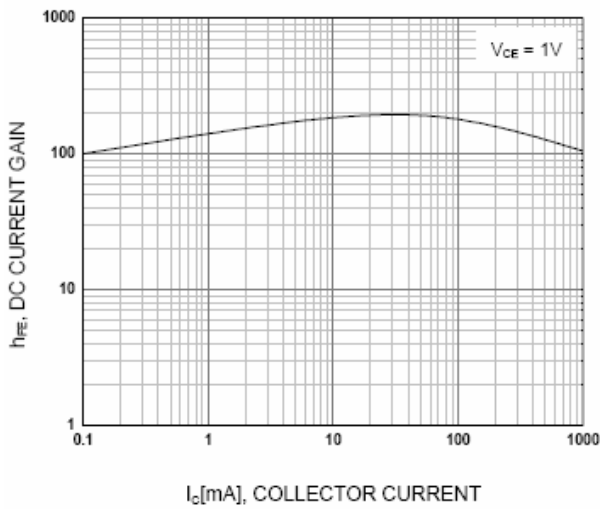

Figure 3. DC current Gain

NPN Silicon Epitaxial Planar Transistor

M28S

PACKAGE OUTLINE

Plastic surface mounted package

SOT-23

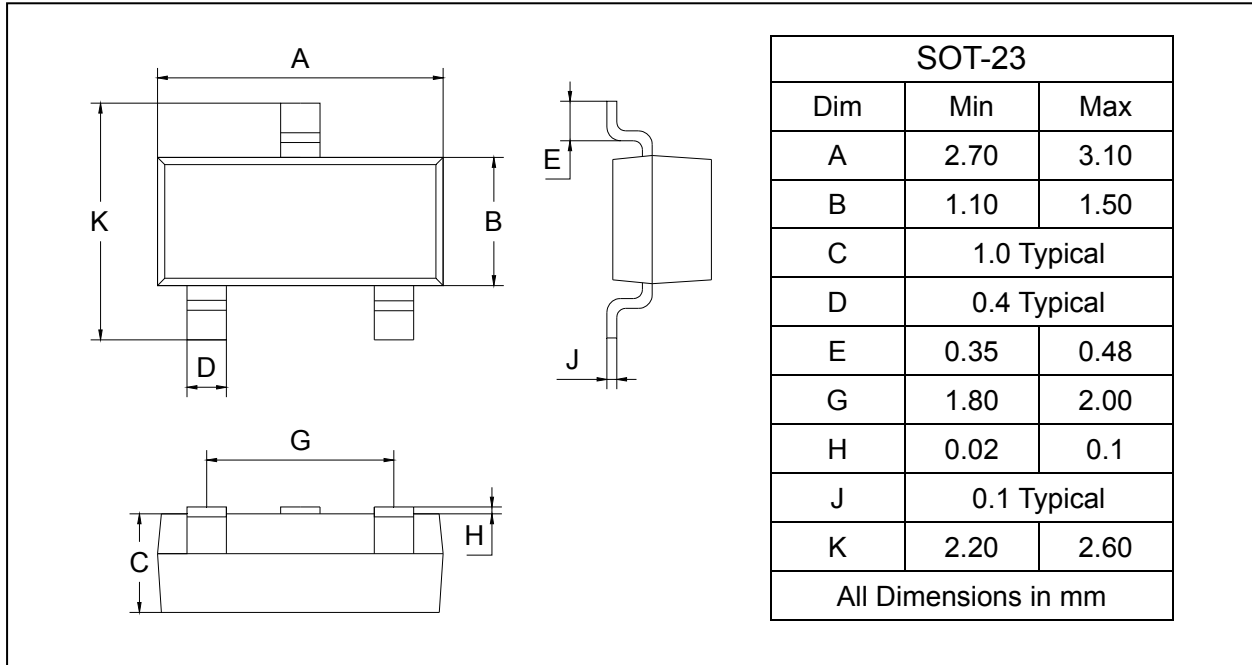

SOLDERING FOOTPRINT

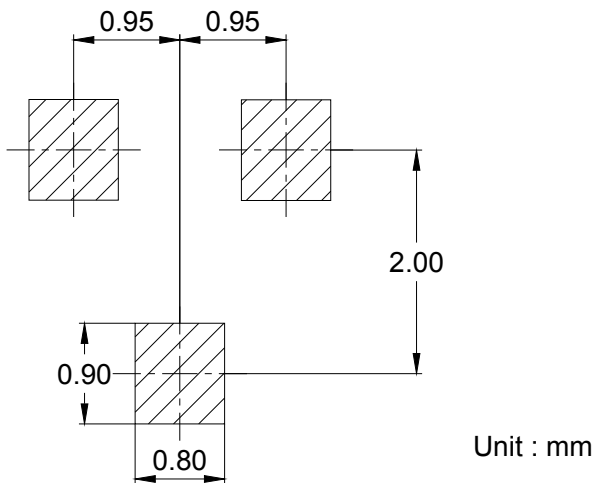

PACKAGE INFORMATION

Device	Package	Shipping
M28S	SOT-23	3000/Tape&Reel