



M28S

NPN SILICON TRANSISTOR

AUDIO OUTPUT DRIVER AMPLIFIER

■ FEATURES

- * Excellent HFE Linearity
- * High DC Current Gain
- * High Power Dissipation

■ APPLICATION

- * Audio Output Driver Amplifier
- * General Purpose Switch

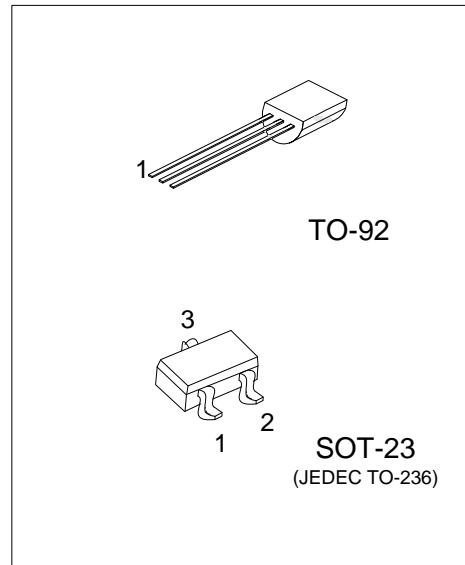

■ ORDERING INFORMATION

Ordering Number		Package	Pin Assignment			Packing
Lead Free	Halogen Free		1	2	3	
M28SL-x-AE3-R	M28SG-x-AE3-R	SOT-23	B	E	C	Tape Reel
M28SL-x-T92-B	M28SG-x-T92-B	TO-92	E	C	B	Tape Box
M28SL-x-T92-K	M28SG-x-T92-K	TO-92	E	C	B	Bulk

Note: Pin Assignment: B: Base E: Emitter C: Collector

<p>M28SG-x-AE3-R</p> <ul style="list-style-type: none"> (1) Packing Type (2) Package Type (3) Rank (4) Green Package 	<ul style="list-style-type: none"> (1) B: Tape Box, K: Bulk, R: Tape Reel (2) AB3: SOT-23, T92: TO-92 (3) x: refer to Classification of h_{FE1} (4) G: Halogen Free and Lead Free, L: Lead Free
--	--

■ MARKING

SOT-23	TO-92
<p>L: Lead Free G: Halogen Free</p>	<p>UTC M28S Rank ← → Date Code L: Lead Free G: Halogen Free</p>

■ ABSOLUTE MAXIMUM RATING ($T_A=25^\circ\text{C}$, unless otherwise specified)

PARAMETER		SYMBOL	RATINGS	UNIT
Collector-Base Voltage		V_{CB0}	40	V
Collector-emitter Voltage		V_{CE0}	20	V
Emitter-Base Voltage		V_{EB0}	6	V
Collector Current		I_C	1.25	A
Base Current		I_B	0.4	A
Power Dissipation ($T_A=25^\circ\text{C}$)	SOT-23	P_D	300	mW
	TO-92		850	mW
Junction Temperature		T_J	+150	$^\circ\text{C}$
Storage Temperature		T_{STG}	-55 ~ +150	$^\circ\text{C}$

Note: Absolute maximum ratings are those values beyond which the device could be permanently damaged. Absolute maximum ratings are stress ratings only and functional device operation is not implied.

■ ELECTRICAL CHARACTERISTICS ($T_A=25^\circ\text{C}$, unless otherwise specified)

PARAMETER		SYMBOL	TEST CONDITIONS	MIN	TYP	MAX	UNIT
Collector-Base Voltage		V_{CB0}	$I_C=0.1\text{mA}$	40			V
Collector-Emitter Voltage		V_{CE0}	$I_C=1\text{mA}$	20			V
Emitter-Base Voltage		V_{EB0}	$I_E=0.1\text{mA}$	6			V
Collector Cutoff Current		I_{CB0}	$V_{CB}=35\text{V}, I_E=0$			100	nA
Emitter Cutoff Current		I_{EB0}	$V_{EB}=5\text{V}, I_C=0$			100	nA
ON CHARACTERISTICS							
DC Current Gain (Note)	h_{FE1}	$V_{CE}=1\text{V}, I_C=1\text{mA}$	290				
	h_{FE2}	$V_{CE}=1\text{V}, I_C=0.1\text{A}$	300		1000		
	h_{FE3}	$V_{CE}=1\text{V}, I_C=0.3\text{A}$	300				
	h_{FE4}	$V_{CE}=1\text{V}, I_C=0.5\text{A}$	300				
Collector-Emitter Saturation Voltage		$V_{CE(SAT)}$	$I_C=600\text{mA}, I_B=20\text{mA}$			0.55	V
SMALL-SIGNAL CHARACTERISTICS							
Current Gain Bandwidth Product		f_T	$V_{CE}=10\text{V}, I_C=50\text{mA}, f=1\text{MHz}$	100			MHz
Output Capacitance		C_{OB}	$V_{CB}=10\text{V}, I_E=0, f=1\text{MHz}$		9		pF

■ CLASSIFICATION OF h_{FE2}

RANK	B	C	D
RANGE	300-550	500-700	650-1000

UTC assumes no responsibility for equipment failures that result from using products at values that exceed, even momentarily, rated values (such as maximum ratings, operating condition ranges, or other parameters) listed in products specifications of any and all UTC products described or contained herein. UTC products are not designed for use in life support appliances, devices or systems where malfunction of these products can be reasonably expected to result in personal injury. Reproduction in whole or in part is prohibited without the prior written consent of the copyright owner. UTC reserves the right to make changes to information published in this document, including without limitation specifications and product descriptions, at any time and without notice. This document supersedes and replaces all information supplied prior to the publication hereof.